



hot
cold
warm

URAN SOKOLI

HOT COLD WARM

2021

HOT // COLD // WARM

Reintroducing the Public Bathhouse to the American Society

Uran Sokoli

Texas A&M University
Department of Architecture
2020-2021

acknowledgments

First and foremost, I would like to thank the chair of my committee, Dr. Ahmed Ali. I am grateful for our weekly conversations with valuable guidance and in-depth suggestions. The successful completion of this project would not have been possible without his support.

I am thankful to my committee members, Dr. Xuemei Zhu and Dr. John Spengler, and studio professor, Brian Gibbs for their encouragement and insightful comments which helped me to work on my ideas and achieve my vision for this project.

Finally, I am thankful to my family for the unconditional love and support in every aspect of life. Thank you for your support of my study abroad.

committee

Chair: Dr. Ahmed K. Ali, PhD
Assistant Professor, Department of Architecture

Member: Dr. Xuemei Zhu, PhD
Associate Professor, Department of Architecture

Member: Dr. John Spengler, JD, PhD
Professor, Department of Health Promotion & Community Health Sciences

Studio Professor: Brian Gibbs
Visiting Lecturer, Department of Architecture

content

part I

History of Bathhouses	9
Health Benefits	13
Precedents	15
Site Selection	17

part II

Context Analysis	27
Site Analysis	29
Program	33
Structural Types	34
Precedents	35
Space Program	37

part III

Site Photos	44
Concept	45
Materials	47
Design Exploration	49
Site Plan	53
Section	59
Enclosure	65
Exploded diagram	67
Floor plans	69
Sections	75
Hot Cold Warm	85
Structure	95
Roof Plan	97
Details	99
Conclusion	104
Bibliography	105

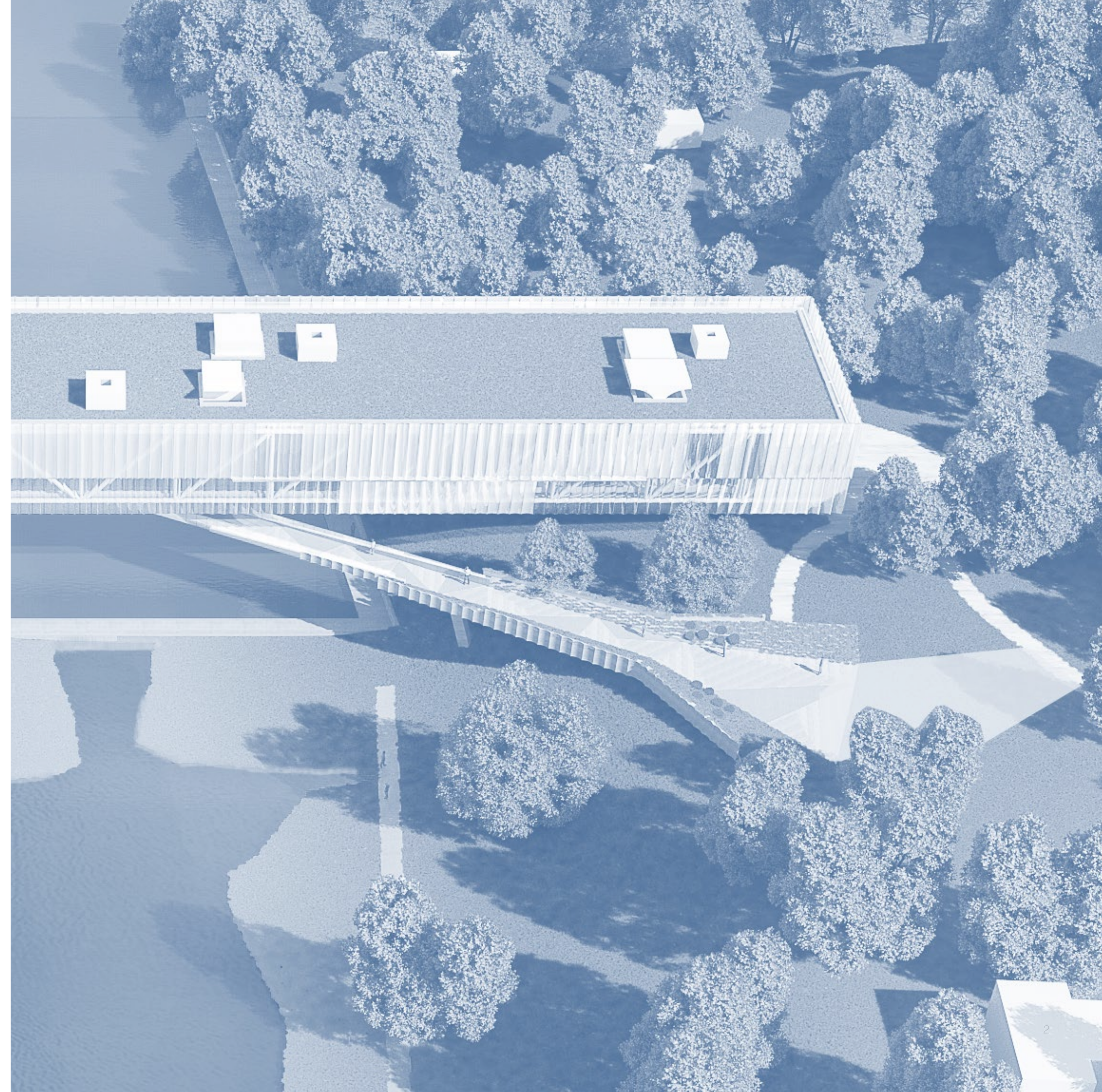

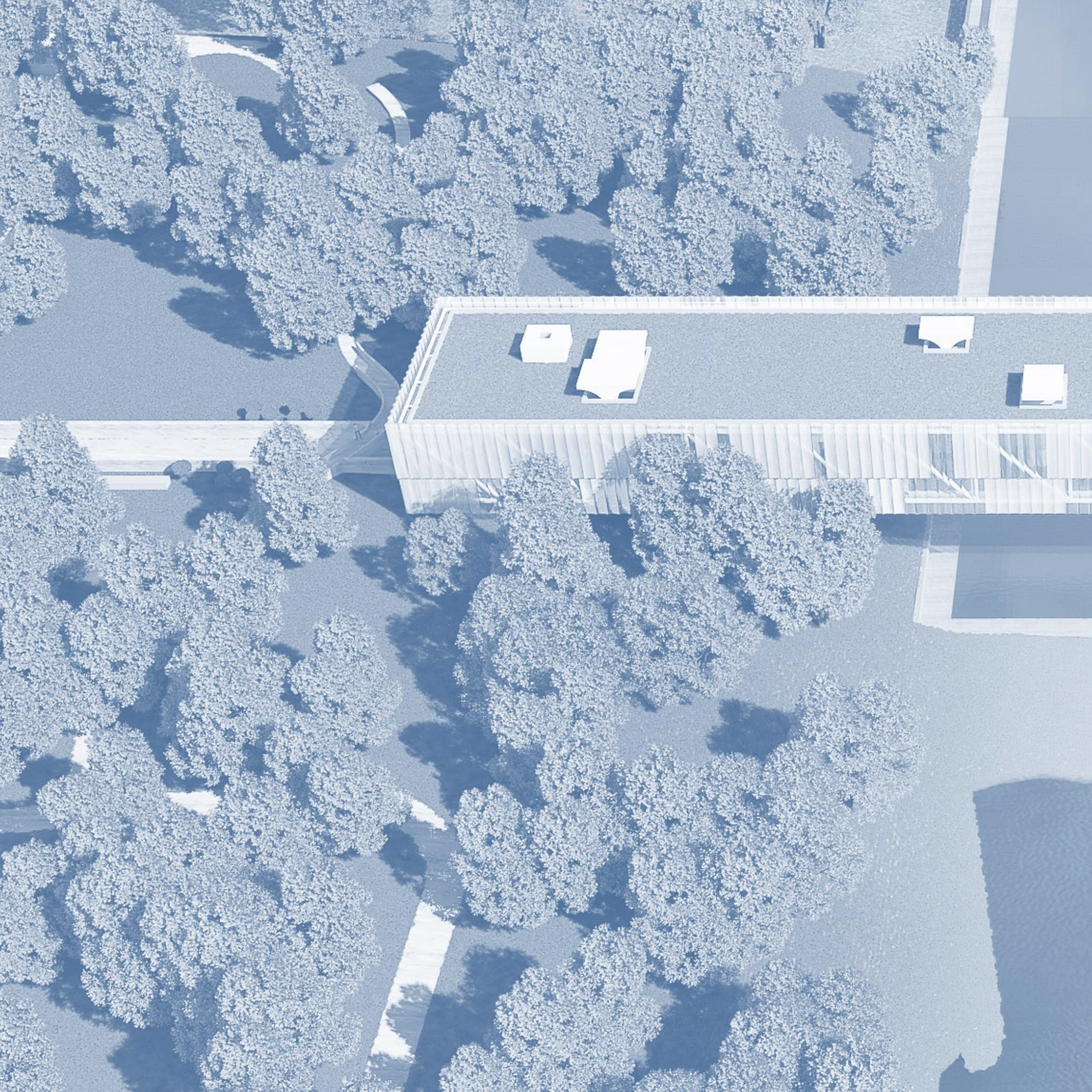

abstract

Reintroducing the public bathhouse to the American Society focuses on the important historical role of this typology in addressing public health and wellbeing. In its beginnings the bathhouse served as a cleansing facility, while in modern times this function has shifted to the shower cubicle. While the function appears to have remained the same, there is a big difference to the archetype of bathing. Societies have historically searched for ways to create physical contact with water, but throughout history the same elements such as Spiritual, Hygienic, Therapeutic, and Social appear to have remained constant over time. (Croutier, 1992)

"The role that bathing plays within a culture reveals the culture's attitude toward human relaxation. It is a measure of how far individual well-being is regarded as an indispensable part of community life."

(Giedion, 1948)

the process ...

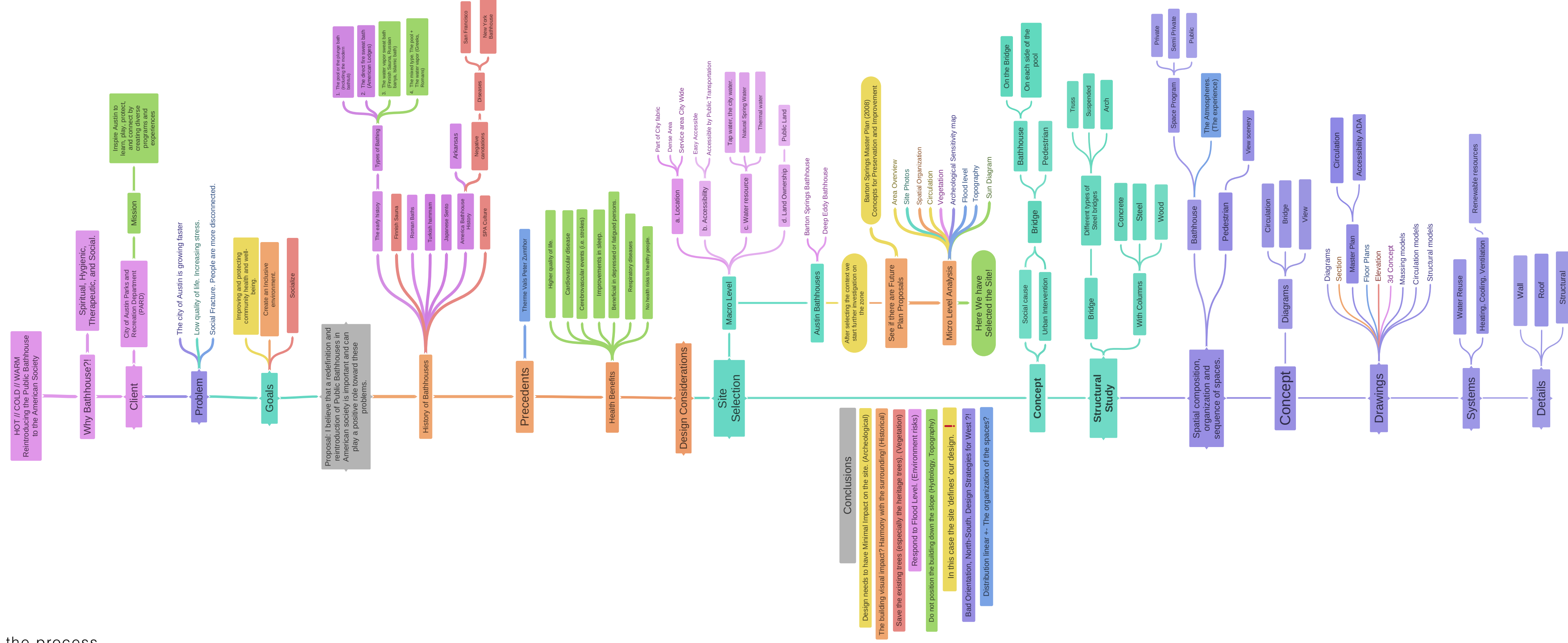

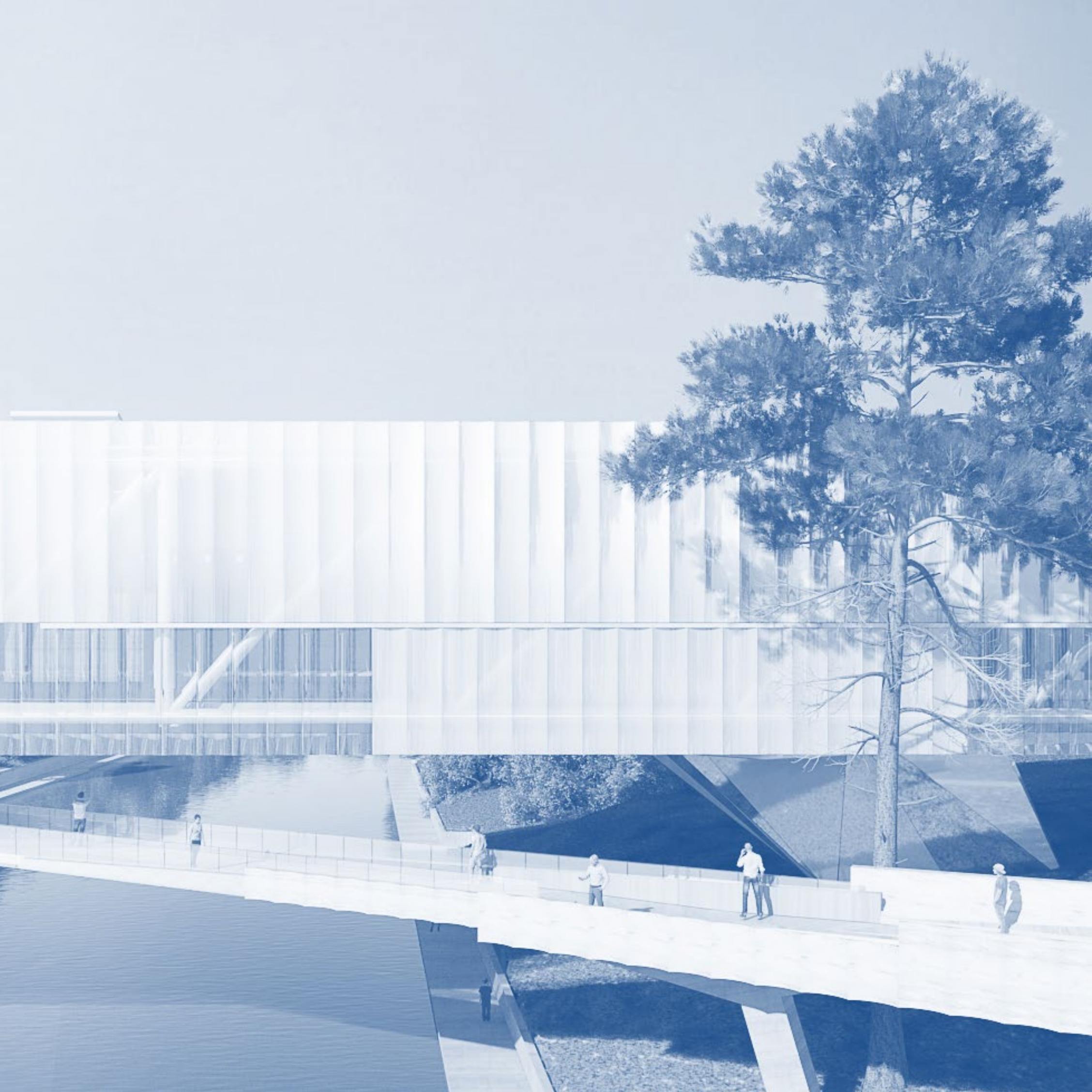

part I

History of Bathhouses	9
Health Benefits	13
Precedents	15
Site Selection	17

early history

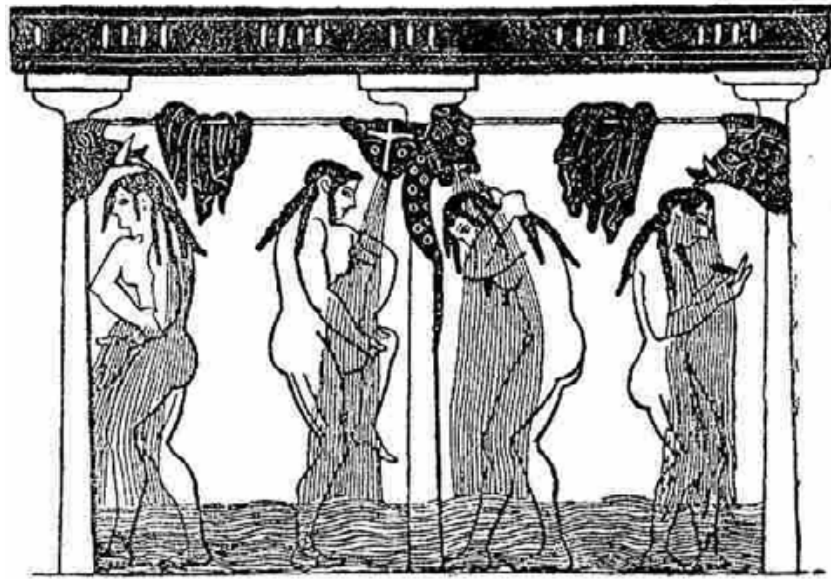

Shower Baths for women. (From a greek vase)

Greek Baths

Around the 6th century BC, when the idea of hot bath has emerged, the Greeks started to build Public Bathhouses. In general, the plan was a simple rectangle around 850 square feet. During that time, the baths were build as part of the greek gymnasium.



Baths of Diocletian

Roman Baths

The peak of Public Bathhouses is seen during the Roman empire. There were two categories, Thermae and Balneae. The first one referred to large scale complexes whereas the balneae were smaller, usually for private use. In Rome, bathing it was one of the most common daily activities. The main rooms were the hot, cold and warm bath. Their use was not only for cleaning but also for socializing. For instance, discussing the daily events in these baths was very common.



Turkish Bath in Acre

Turkish Hammam

The Hammam was inspired by the Roman baths. The earliest hammams could be found as early as the 7th century. Being very functional even in modern times they are an important part of Turkish culture. These bathhouses promoted public health, and they are an ideal place for relaxation, rejuvenation, and solitude. Hammams were generally single-sex, with men and women having separate bathing times.

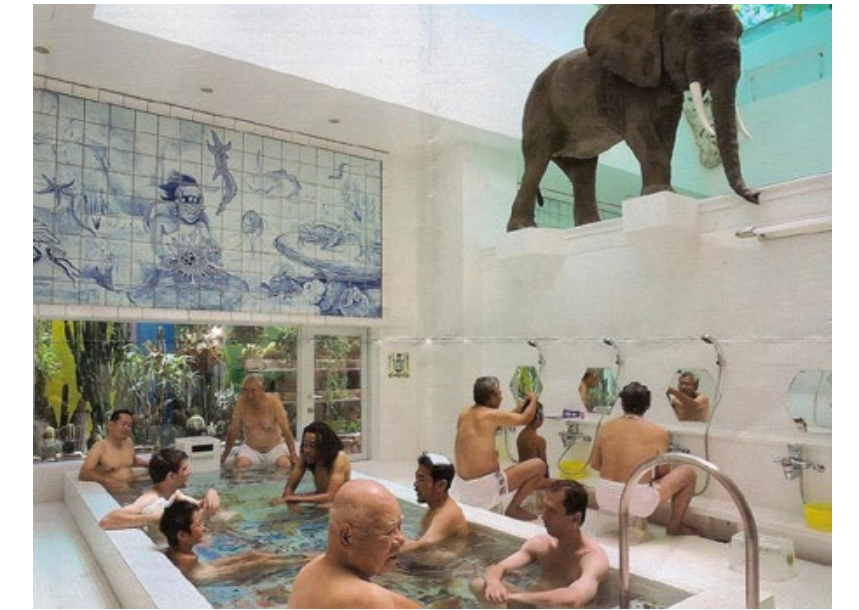

Naoshima Bath

Japanese Sento

There are three types of Japanese baths: (i) Onsen (ii) Sento (iii) Furo. The name is related to the location and the access to spring water. Different from the other bathhouses, Sentos are known to be popular and more frequently due to affordable prices.



La fayette Place

Russian Banya

In Russia, the word banya refers to a public bathhouse. One of the oldest banya is Sanduny, built in 1806. People frequented these spaces for spiritual experience. However, nowadays banyas are gender separated.

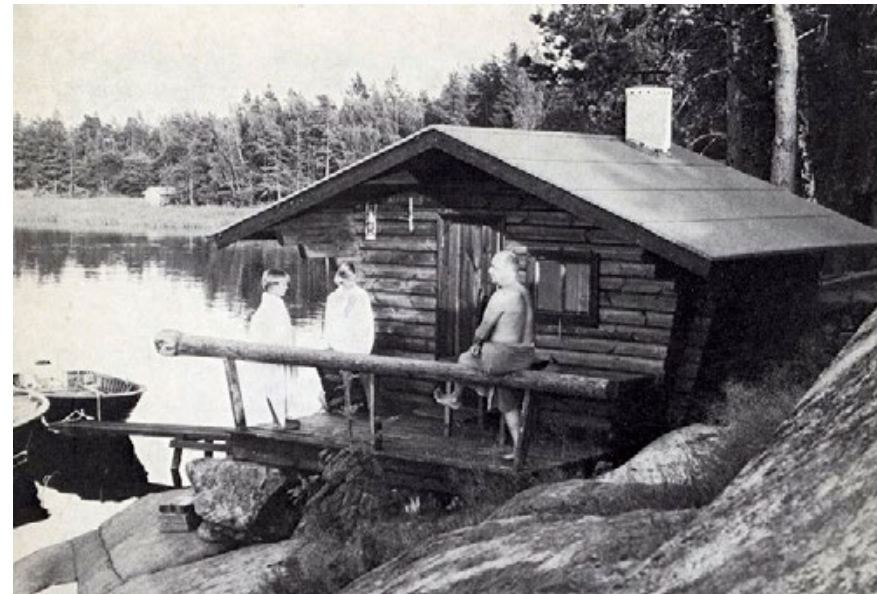

Finnish sauna

Finnish Sauna

Saunas or steam baths are ubiquitous in Finland. It is almost seen in every household and traditionally Saturday is known as the sauna day. Moreover, saunas have been used for rituals on many occasions like childbirth, marriage, and even in deaths. (Aaland, 1997) The steam is created by pouring water over heated stones.



Swimming Bath, Harper's Weekly, 1870.

America, 1840's

The first Bathhouses started to be built in America during the 1840's for the cleansing of the poor. In the late 19's, due to increased migration from Finland the sauna came with them. This is the time when the American Society become known with this typology. Sauna suddenly became very popular, but it was used more as a commercial industry detached from the original social model of the Finnish archetype.

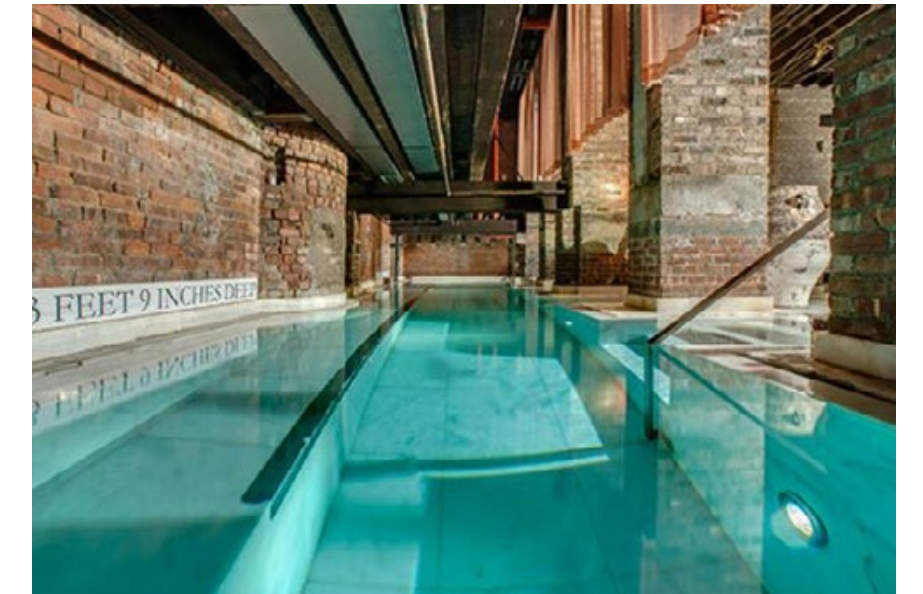

SPA, New York

Today

Today, the Bath culture is replaced by SPA culture, which usually refers a place for relaxation, rejuvenation and contemplation. Even though they try to replace the bathing culture, still SPA's have become increasingly private and are not affordable by all society classes.

HYGIENIC

THERAPEUTIC

SOCIAL

SPIRITUAL

health benefits

Today, when most of the focus has shifted to curative medicine, to treat the sick, the idea of Preventive medicine, where tries to restore and maintain the wellbeing is much more important.

“Preventive medicine focuses on the health of individuals and communities. The goal of preventive medicine is to promote health and well-being and prevent disease, disability and death.” (ACPM, n.d.)

Health Benefits of Hot, Cold and Warm bath

There are a lot of studies and evidence which show the benefits of hot cold and warm Bath. (Tsonis, 2017)

- + Cardiovascular disease;
- + Cerebrovascular events (i.e. strokes);
- + Higher quality of life;
- + Improvements in sleep;
- + Beneficial in depressed, or fatigued persons;
- + Respiratory diseases (i.e. pneumonia, asthma and chronic obstructive pulmonary disease), dementia;
- + Lowered markers of systemic inflammation; and
- + No health risks to healthy people from childhood to old age.



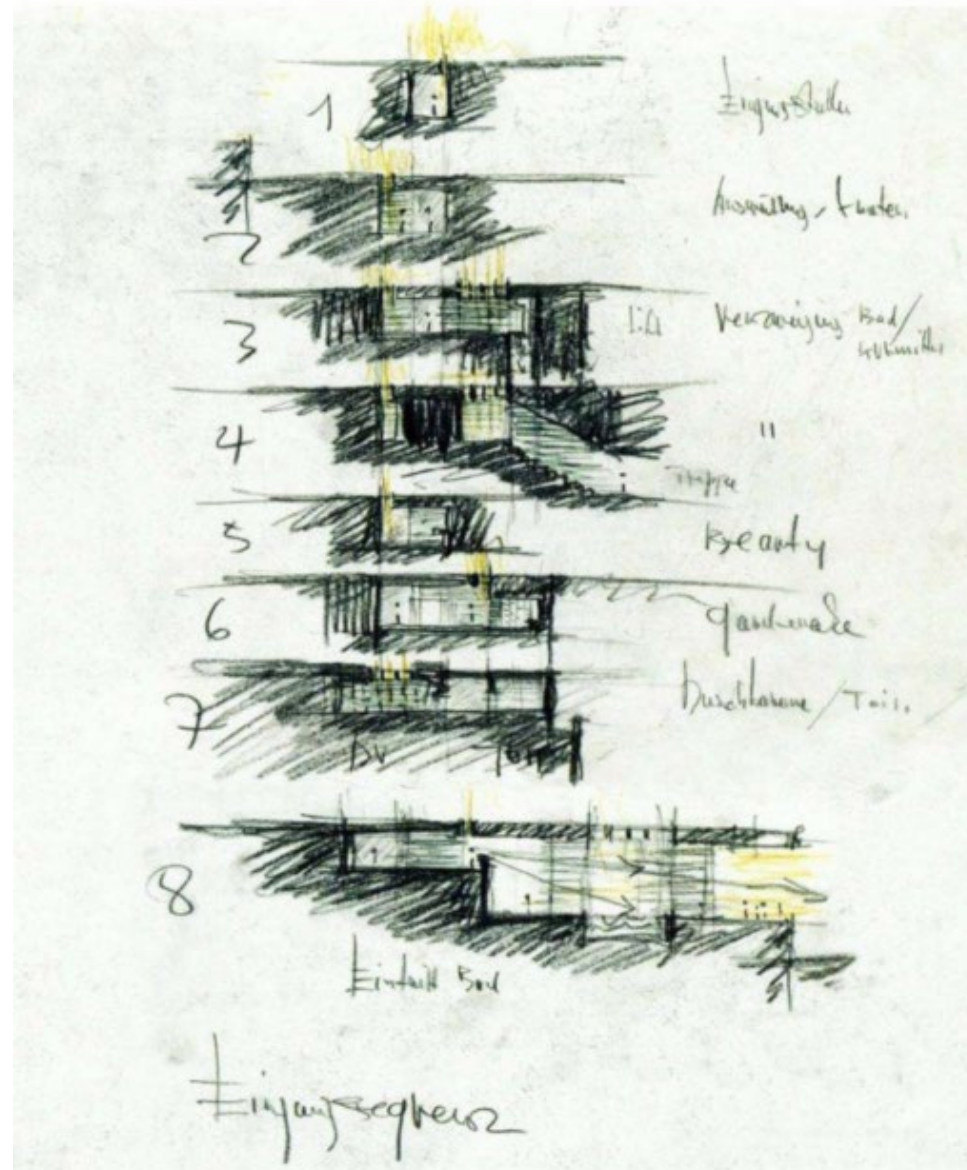
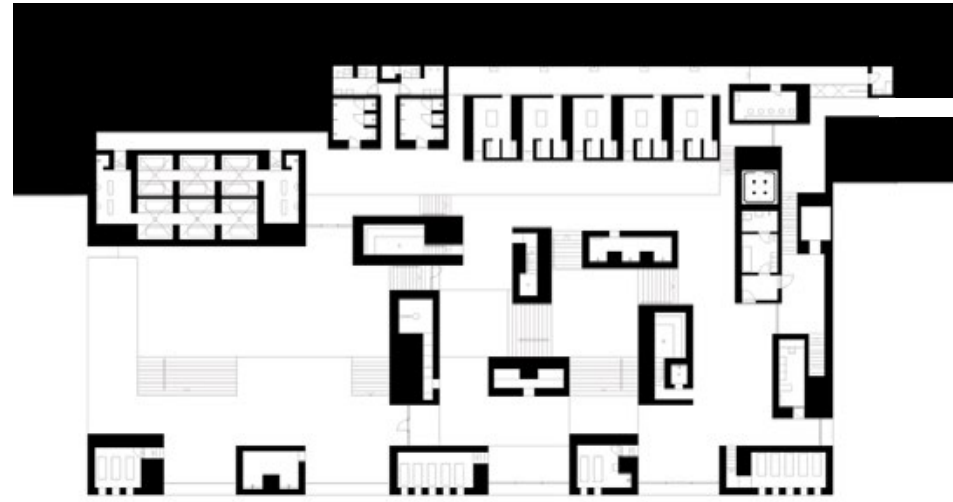

precedents

Thérme Vals
 Architect: Peter Zumthor,
 Year: 1996
 Location: Switzerland

The Thérme Vals by Peter Zumthor is built in 1996. The design is clearly driven by the deep desire of creating powerful atmospheres. Peter Zumthor analyzes very clearly in his book *Atmospheres*, where he emphasizes that the elements needed to create these atmospheres are anatomy, materials, sound of space, temperature, surrounding objects, tension between interior and exterior, levels of intimacy, and most importantly the light. These aspects I have tried to take into consideration and integrate into my design.

The elements needed to create these atmospheres are:

1. Anatomy (Structure)
2. Materials
3. Sound of Space
4. Temperature
5. Surrounding objects
6. Tension between inside and exterior
7. Levels of intimacy
8. The Light



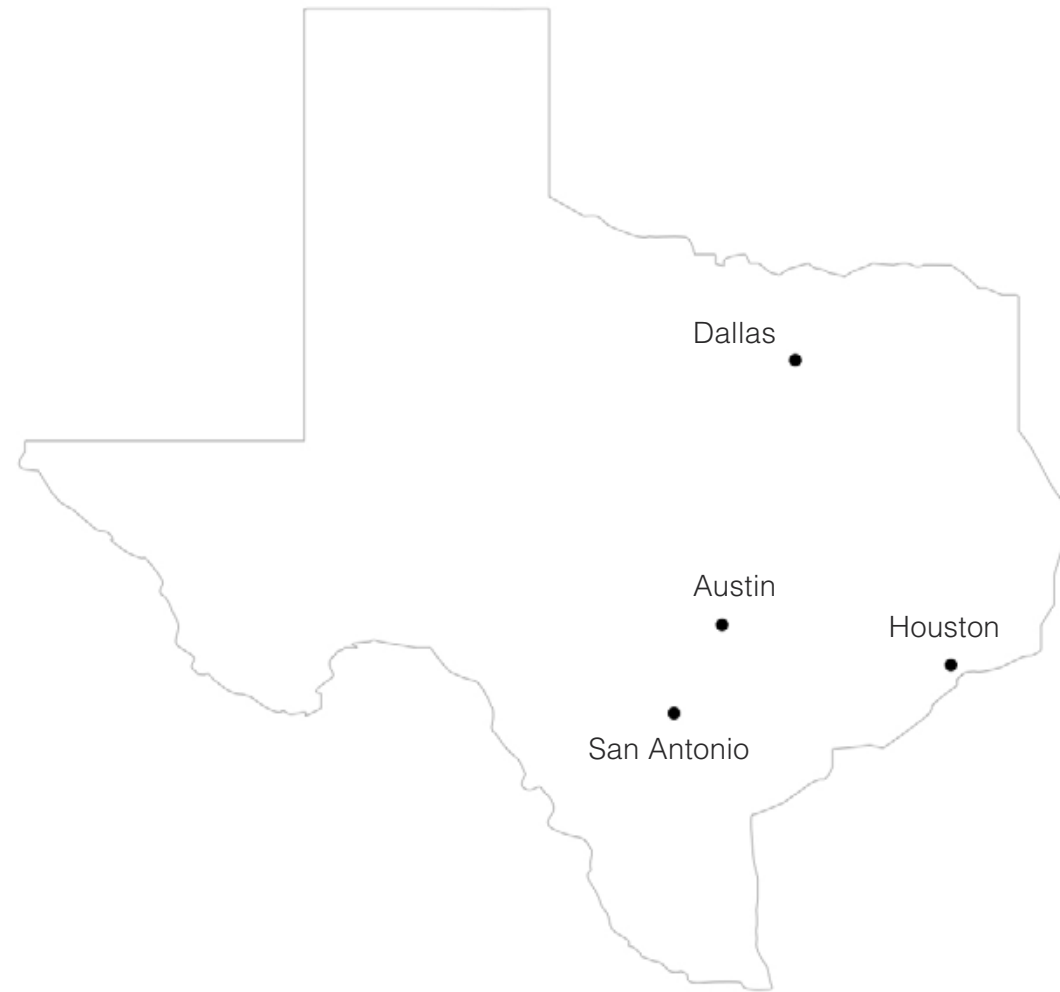

Austin, TX

- The city of Austin is growing faster, and recreational spaces must evolve to meet the needs of the residents. (According to the data, between 2018 and 2040 the city of Austin is projected 45% population growth and 80% job growth.)
- Low quality of life. Increasing stress.
- Social Fracture. People are more disconnected.

goals

- + Improving and protecting community health and well-being.
- + Create an Inclusive environment.
- + Giving the community the opportunity to socialize together.

how?

I believe that a redefinition and reintroduction of Public Bathhouses in American society is important and can play a positive role toward these problems.



Austin, Texas

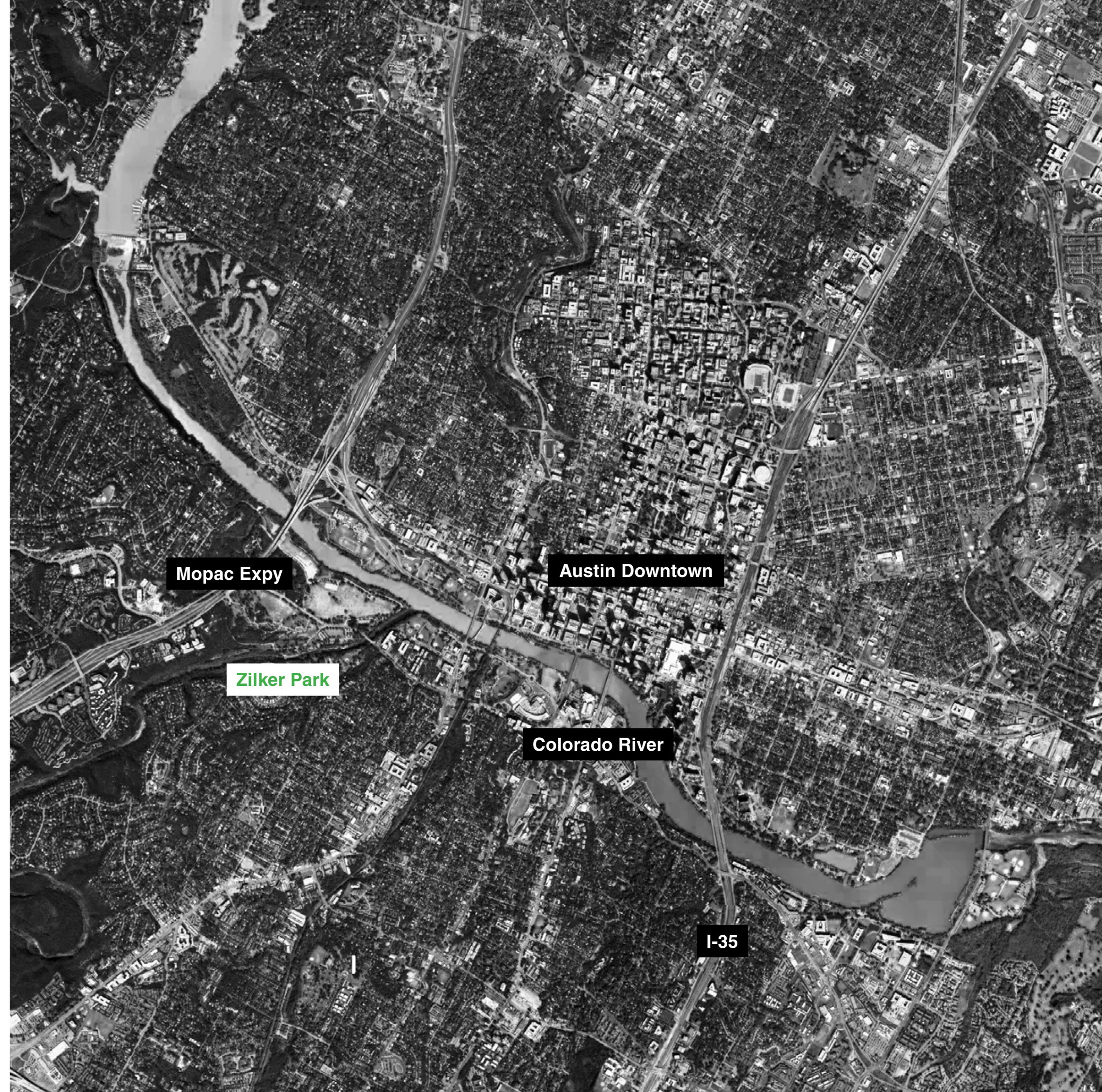

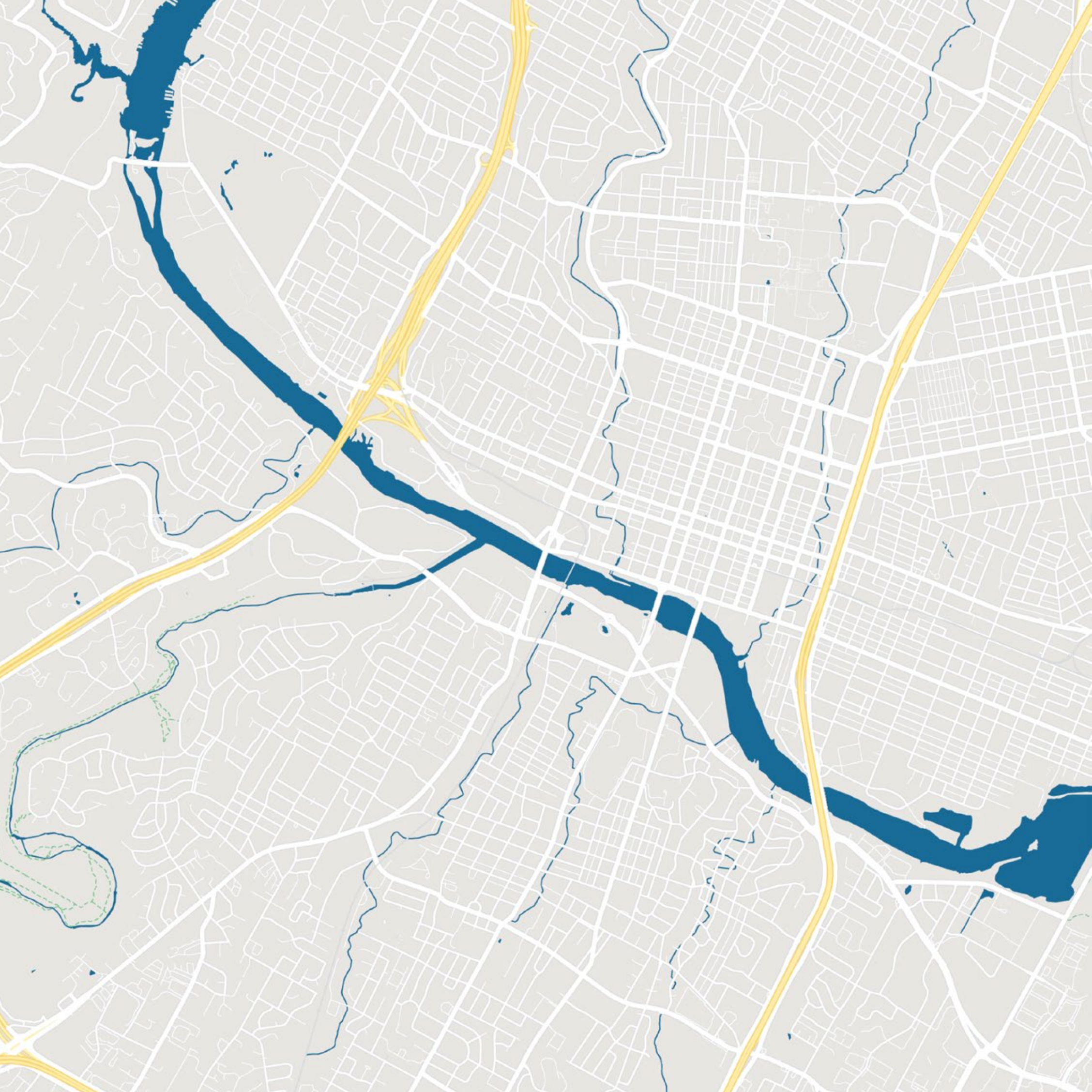

site selection

Site plays a critical role for this typology. So, it was important to choose the right qualities so the site can contribute to our goals. Before selecting the site we did a macro analysis of the City of Austin, and the factors that we took into consideration were: the location, accessibility, water resource and land use.

+ location

Dense Area (serving the whole city)
Located in a dense area is important because this particular location has the potential to serve different classes and cultures. Also, making Bathhouse part of city fabric so it will be frequented more often.

+ accessibility

Easy accessible by public transportation. Located near BUS stations is very important to encourage people to use more the public transportation. The site needs to have at least access from one road, in this way the project will be more feasible.

Austin, Texas

+ water resource

Thermal water
Thermal water comes from hot springs. The water in these hot springs come from deep in the ground, where it's heated by geothermal activity.

Tap water, the city water.
The purification is made by chlorine. There have no minerals. You need to add drugs to control the pH and other elements.

Natural Spring Water,
Water that originates from an underground aquifer. Have some minerals. No need of chlorine to clean it.

+ land

Public Land
The facility will belong to the public and will be managed by the city of Austin. Everyone will pay a small fee to use it. Being in a public land reduces the initial budget costs.

site selection

I wanted the Bathhouse to be part of the city fabric, located in a dense area and serving to the whole city. More importantly to have access to natural spring water.

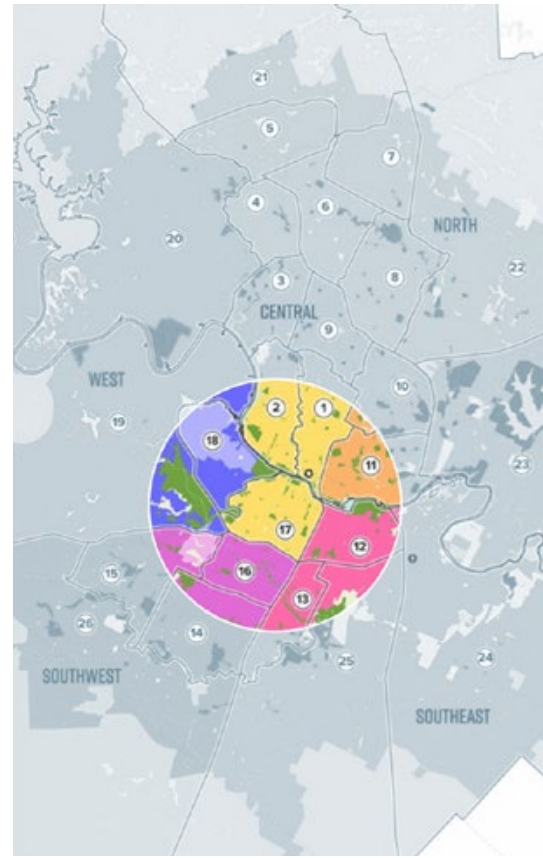

Density

The CENTRAL area captures the majority of Austin's urban core and it is dominated by residents aged 18-65 with small household sizes. This area has the highest population and employment densities and is expected to grow in the future.

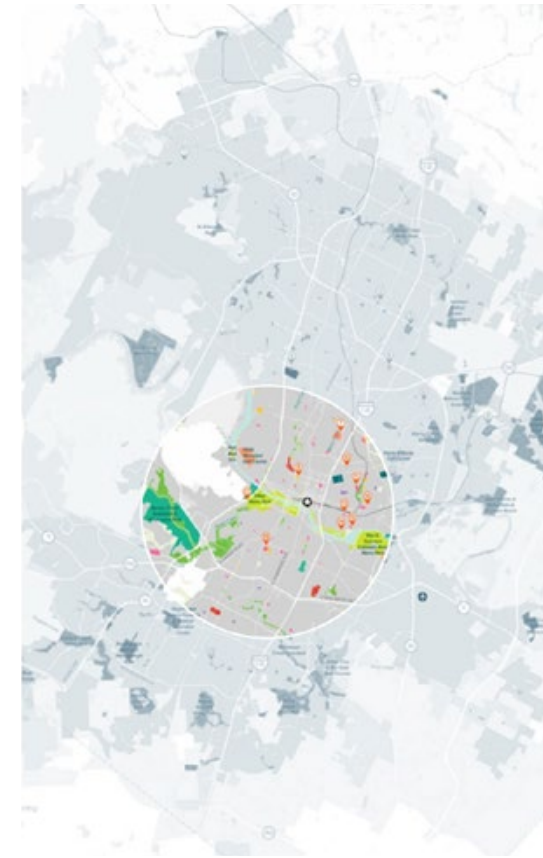

Service Area

The metropolitan zone service area is citywide. (Important for our facility to serve the whole city) Access is very good, by major arterials.



Public Transportation

There is a proposal for a "Central Corridor" which will improve the public transportation in Austin.



Future Zone Planning

The zoning of Downtown Austin has changed from Business District to Urban Mixed-Use zone.

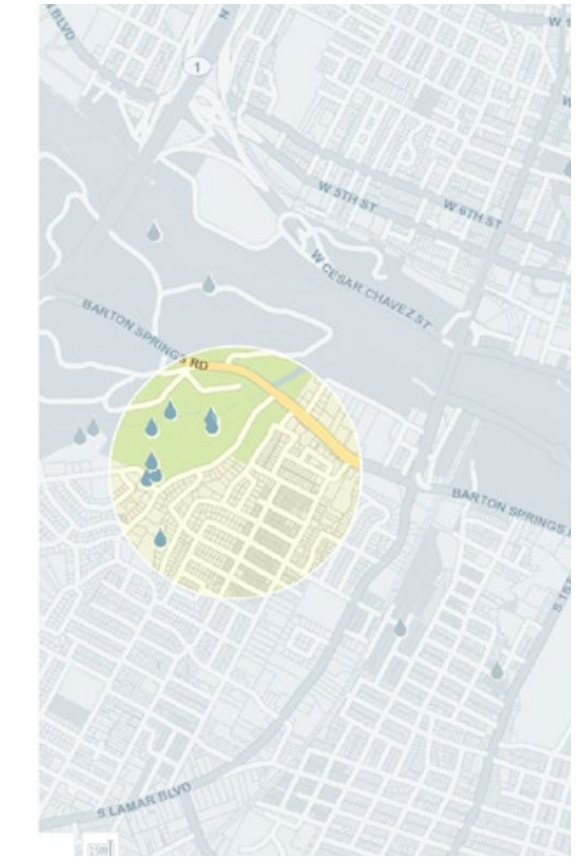

Natural Springs Water

This map shows the locations of Natural Springs water in Austin.



Option 01

- + Downtown
- + Accessible by road
- + Spring water by wells
- + Public land



Option 02

- + Downtown, the most dense area
- + Accessible by public transportation
- + Spring water by wells
- + Public land



Option 03

- + Downtown
- + Accessible by road
- + Spring water by wells
- + Public land



Option 04

- + Near Downtown (Zilker Park)
- + Accessible by road
- + Spring water by wells
- + Public land

site selection

Barton Springs is part of Zilker Park. It attracts a diverse crowd of people, last year nearing 800,000 people. The Pool is around 3 acres in size and is fed from underground springs (Edwards Aquifer). With an average temperature of 68-70 degrees, makes it ideal for year-round swimming.

Option 05

- + Dense Area (serving the whole city)
- + Easy accessible, Public transportation.
- + Natural Spring water
- + Public Land



Barton Springs Pool, Zilker Park





part II

Context Analysis	27
Site Analysis	29
Program	33
Structural Types	34
Precedents	35
Space Program	37



north or south

Proposing the building near Barton Springs pool would be ideal, but finding the site where this program will reside was a challenge. At first glance, the site does not provide a space for a new program. The pool serves the North and Southern landscape, and at the same time dividing these two sides.

The question of placing in North or South became an issue. On either side, the building could destroy the existing balance.

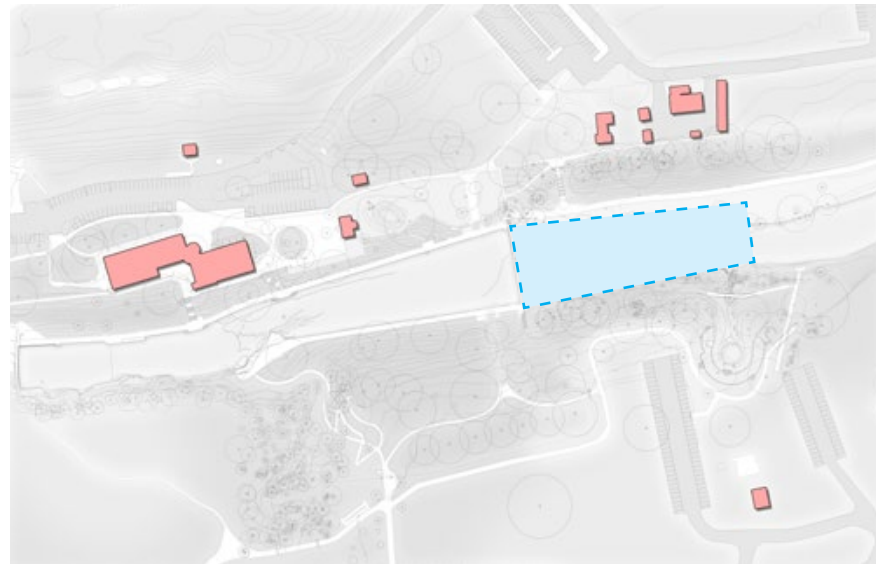

future plan

The 2008 Master Plan proposes to enlarge the pool, almost twice its size.

(Barton Springs Pool Master Plan, Concepts for Preservation and Improvement.)

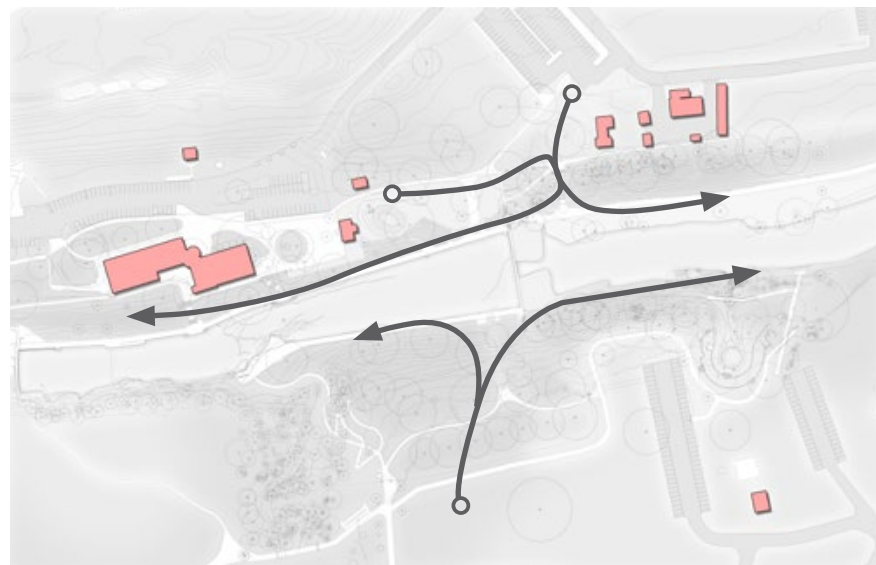

north vs south

The south landscape looks more like a park for the residents around. The parking is free and there are plans for the reconfiguration in the future. Whereas the north landscape usually gets overcrowded. You need to pay for the parking. This policy was implemented to change the behavior of people to make them park in the South.

In conclusion, Barton Springs Pool is the natural divider between the two sides of Zilker Park, creating circulation issues between the North and South.

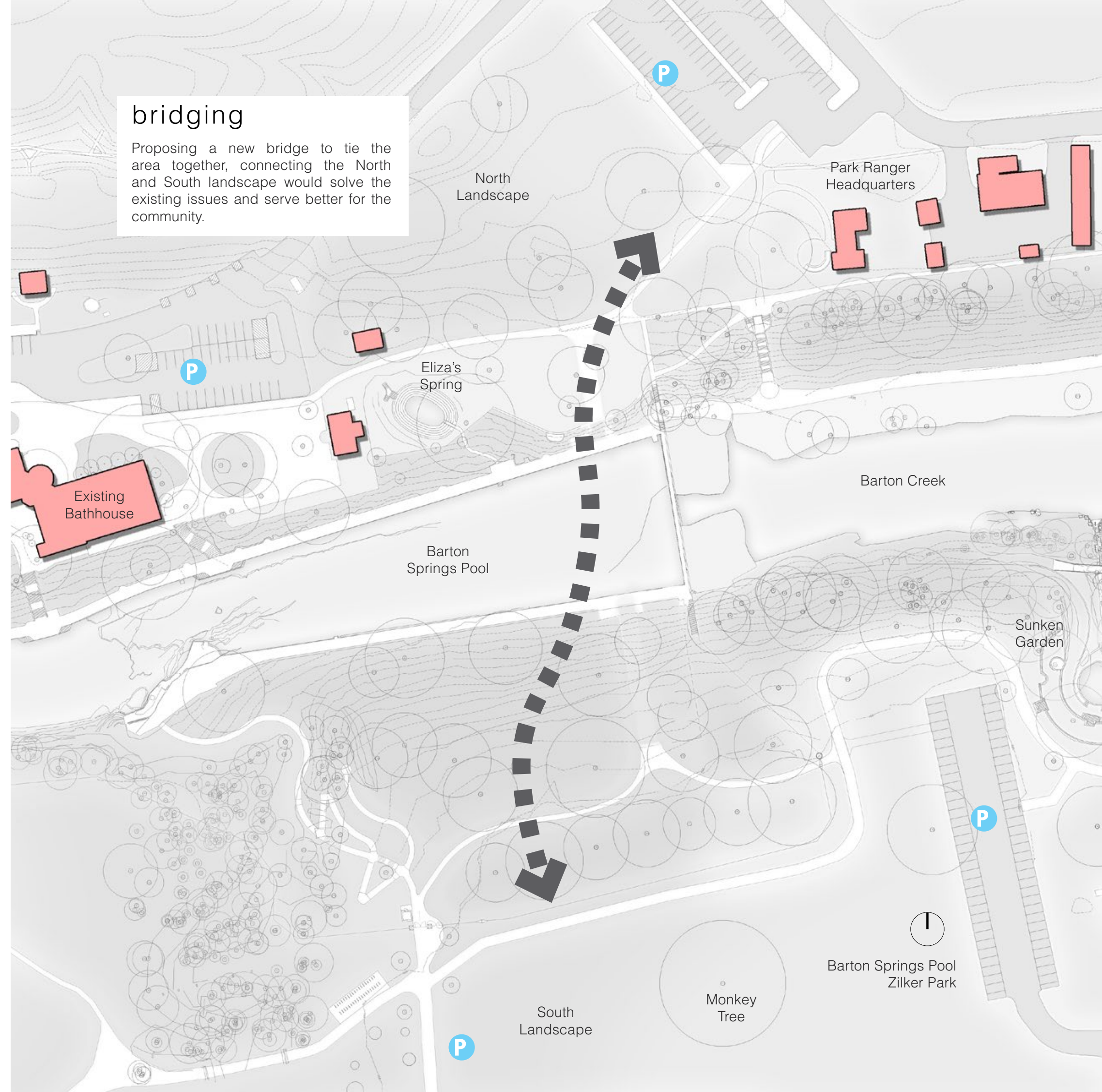

bridging

Proposing a new bridge to tie the area together, connecting the North and South landscape would solve the existing issues and serve better for the community.

site analysis

1. Vegetation map

- D1 - Heritage Trees
- D2 - Other native trees/shrubs
- D3 - Native Tree
- D4 - Grassed Lawns
- D5 - Small planting zone



Map created by Julie McGilvray, 2012.

2. Buildings and Structures

- F1 - Barton Springs road bridge
- F2 - Zilker Gateway
- F3 - Parking lot system
- F4 - Road network
- F5 - Modern restroom buildings.
- F6 - Mirror pond
- F7 - Rollingwood bridge abutments
- F8 - Skeet/pistol range
- F9 - Lookout point
- F10 - Zilker park Clubhouse
- F11 - Recreation center
- F12 - Girl Scout cabin
- F13 - Zilker hillside theatre
- F14 - Rock garden
- F15 - Band stand
- F16 - Zilker christmas tree
- F17 - Sand pit
- F18 - Barton Springs Bathhouse
- F19 - Rock wall system
- F20 - Barton springs concession
- F21 - Barton Springs Pool
- F22 - Barton creek

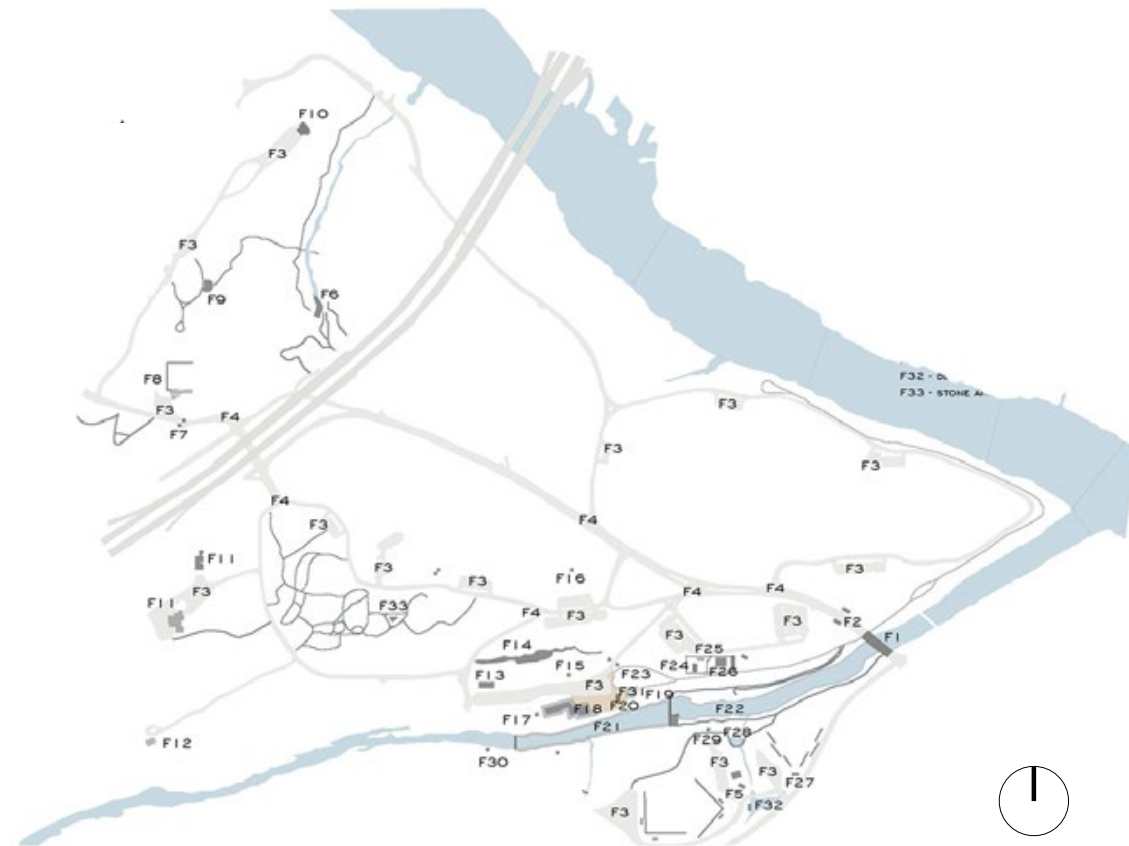

Map created by Julie McGilvray, 2012.

3. Landscape characteristic map

- C1 - Recreational
- C2 - Educational
- C3 - Performance
- C4 - Ceremonial



Map created by Julie McGilvray, 2012.

4. Archeological Sensitivity Map

THC (Texas Historical Commission)

- Requires THC consultation for all construction projects.
- Requires THC consultation for all construction projects.
- Requires THC consultation for all construction projects.
- Unknown area. Consultation with THC recommended.
- No THC consultation needed.

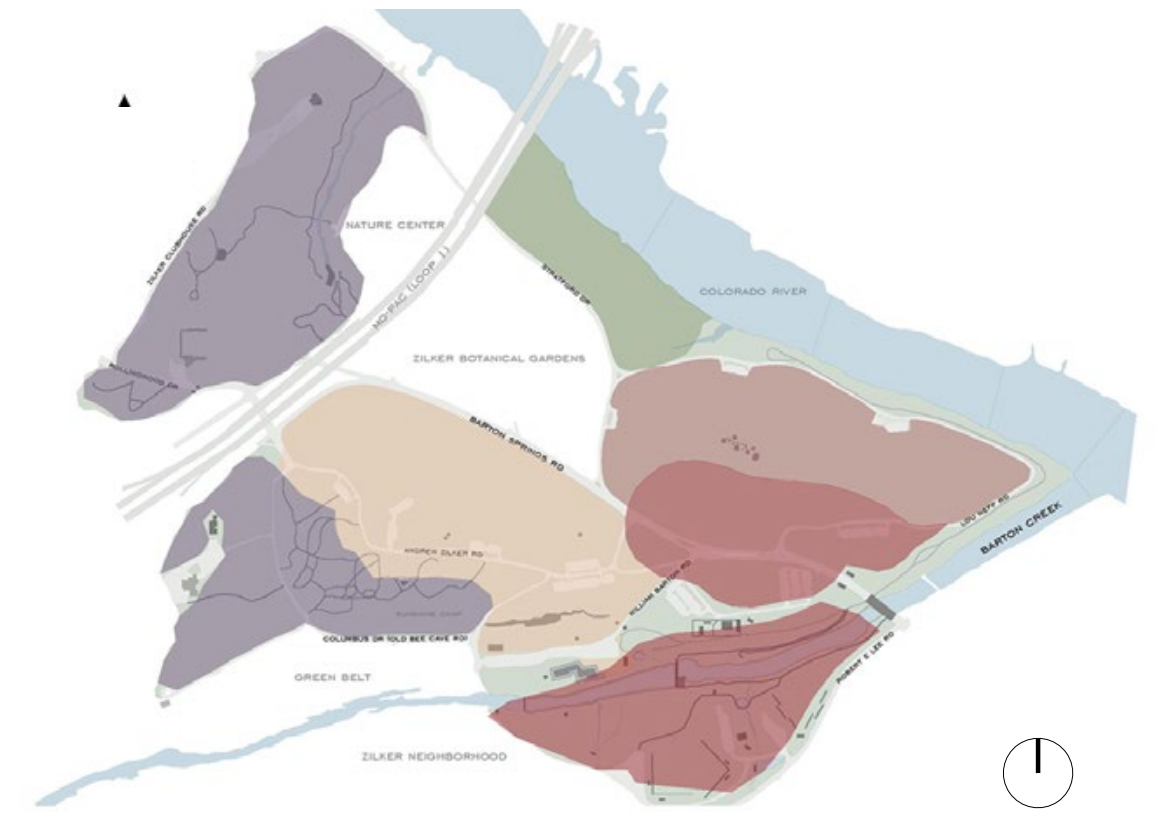

Map created by Julie McGilvray, 2012.

site analysis

5. Vegetation Map

- GREAT CONDITION
Long life expected.
- GOOD CONDITION
Of a variety that may not have a long life, or may tend to become hazardous.
- COMPROMISING FACTORS APPARENT
That can be expected to affect longevity or tendency to become hazardous.
- SHOULD BE ASSESSED
To minimize the potential for hazards
- COMPROMISING DAMAGE APPARENT

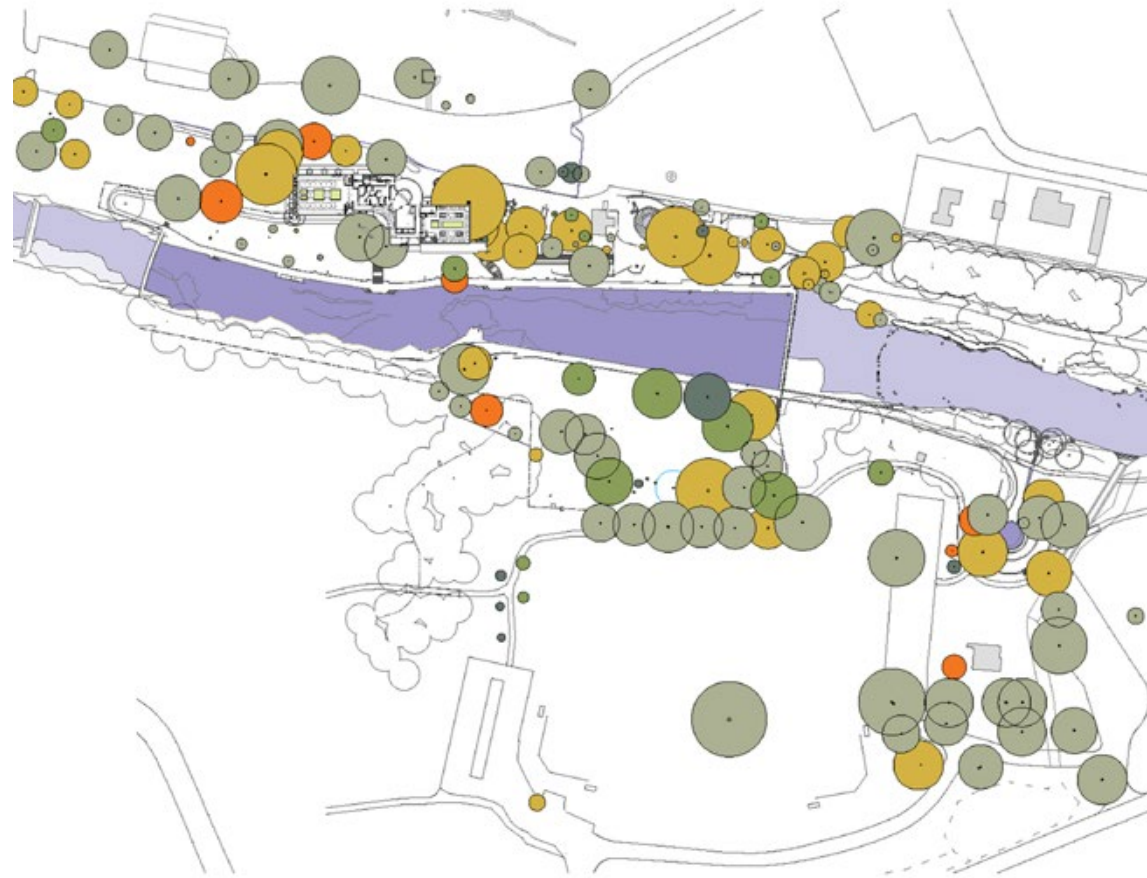

6. Flood level

The FEMA 100-year/City of Austin Fully Developed 25-year flood elevation varies from on this parcel from the most upstream at approximately 465' down to 440' at the downstream end of the property at Barton Springs Road. Flood level - 460 Feet

- FEMA Floodplain
- 100 Year (Detailed-AE)
 - 100 Year (Shallow-AO)
 - 100 Year (Approx-A)
 - X Protected by Levee
 - 500 Years

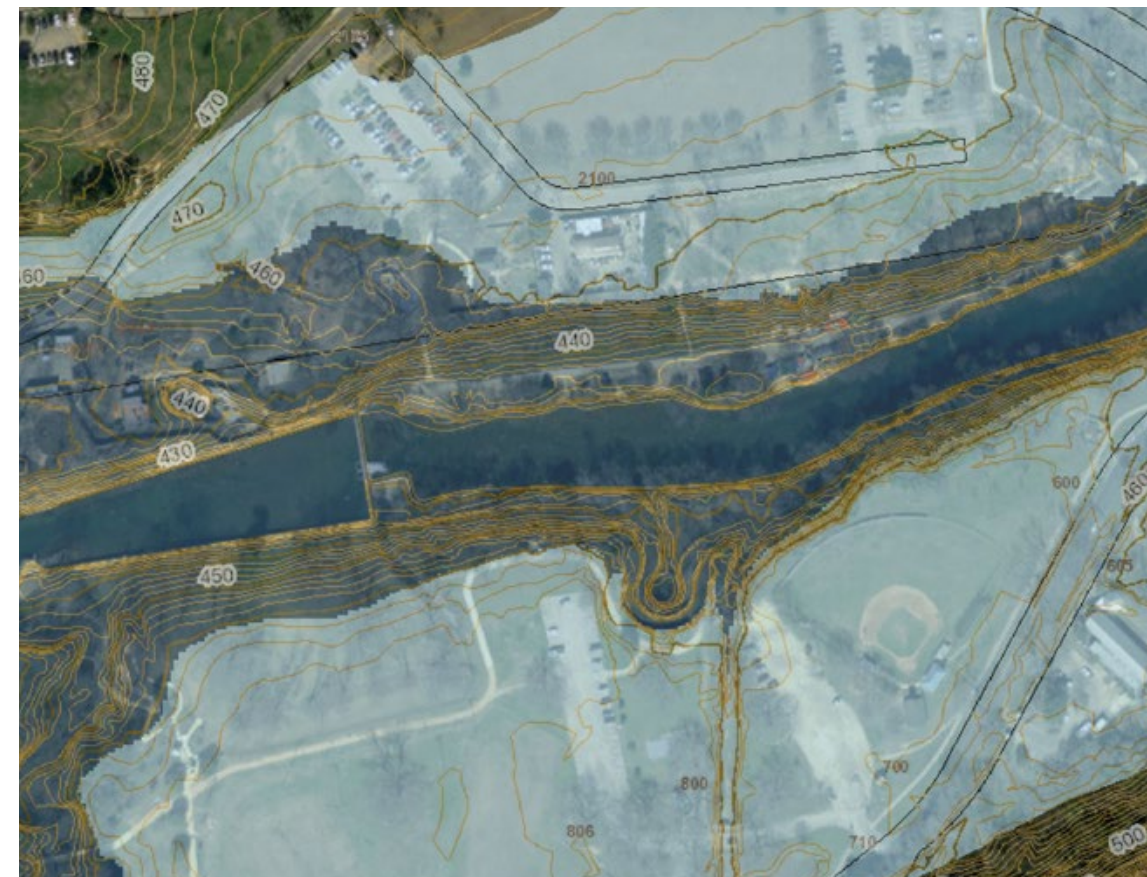

conclusions

After analyzing the site we came into these conclusions which we should take into consideration prior of starting the design process.

- 1 Design needs to have Minimal Impact on the site. (Archeological)
- 2 The building visual impact? Harmony with the surrounding! (Historical)
- 3 Preserve the existing heritage trees (Vegetation)
- 4 Respond to Flood Level. (Environment risks)
- 5 The organization of the spaces. Linear Distribution.
- 6 Not very good orientation, North-South. Design Strategies for the West.

program

These diagrams analyze different options of the relationship between the Bathhouse and the pedestrian bridge.

Advantages + / - Disadvantages

Option 01

- + Easily accessible
- Not visually connected with the site.
- Negative experience because a continuous wall will accompany the visitors through all the bridge.



Option 02

- + Easily accessible
- + Creates shadow
- + Better experience

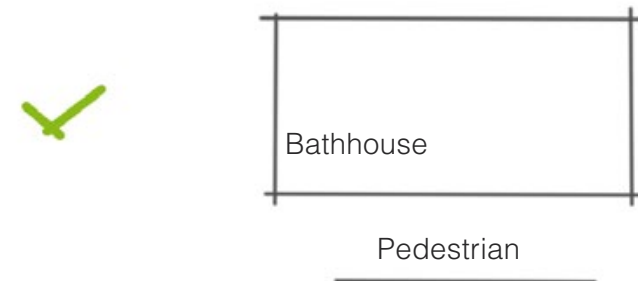

Option 03

- Difficult to be accessed from the pedestrian level
- + No need for two structural systems.

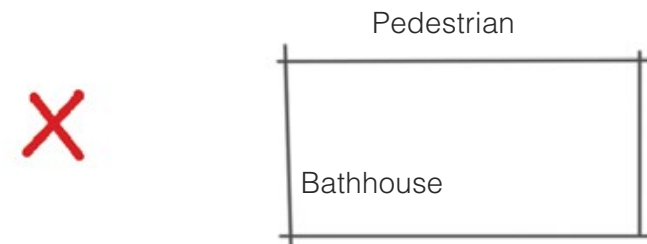

steel structures

The distance between two sides can go from 150 feet (45m) minimum up to 300 feet (100m).

The span 250 foot
Height 30 foot
Width 49 foot



a. Suspension bridge

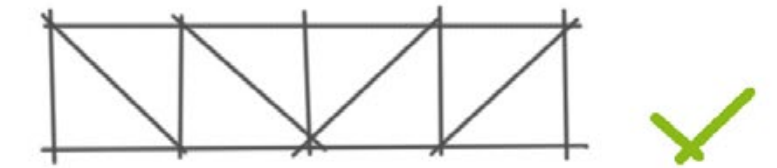

b. Truss bridge



c. Cable Stayed bridge

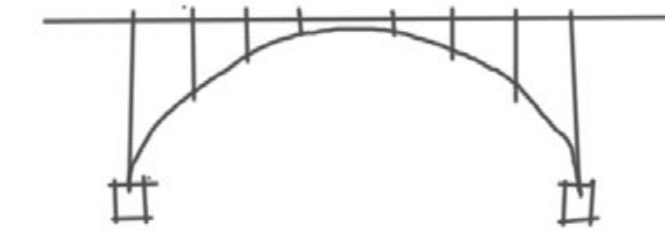

d. Arch bridge

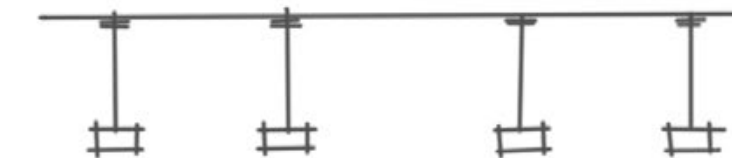

e. Beam bridge

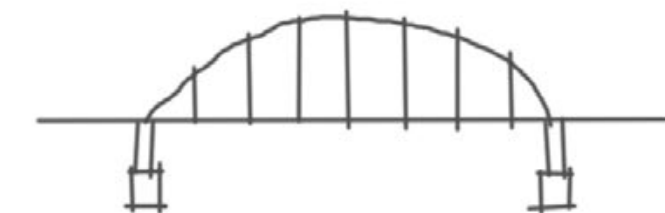

f. Tied Arch bridge

precedents

The Twist Museum
Architects: Bjarke Ingels Group
Area: 1000 sqm
Year: 2019
Location: Norway

The Twist Museum is conceived as a beam twisted 90 degrees. The span is 200 feet. The structure is made of steel truss. The primary goal of the Museum is to improve the park's circulation.

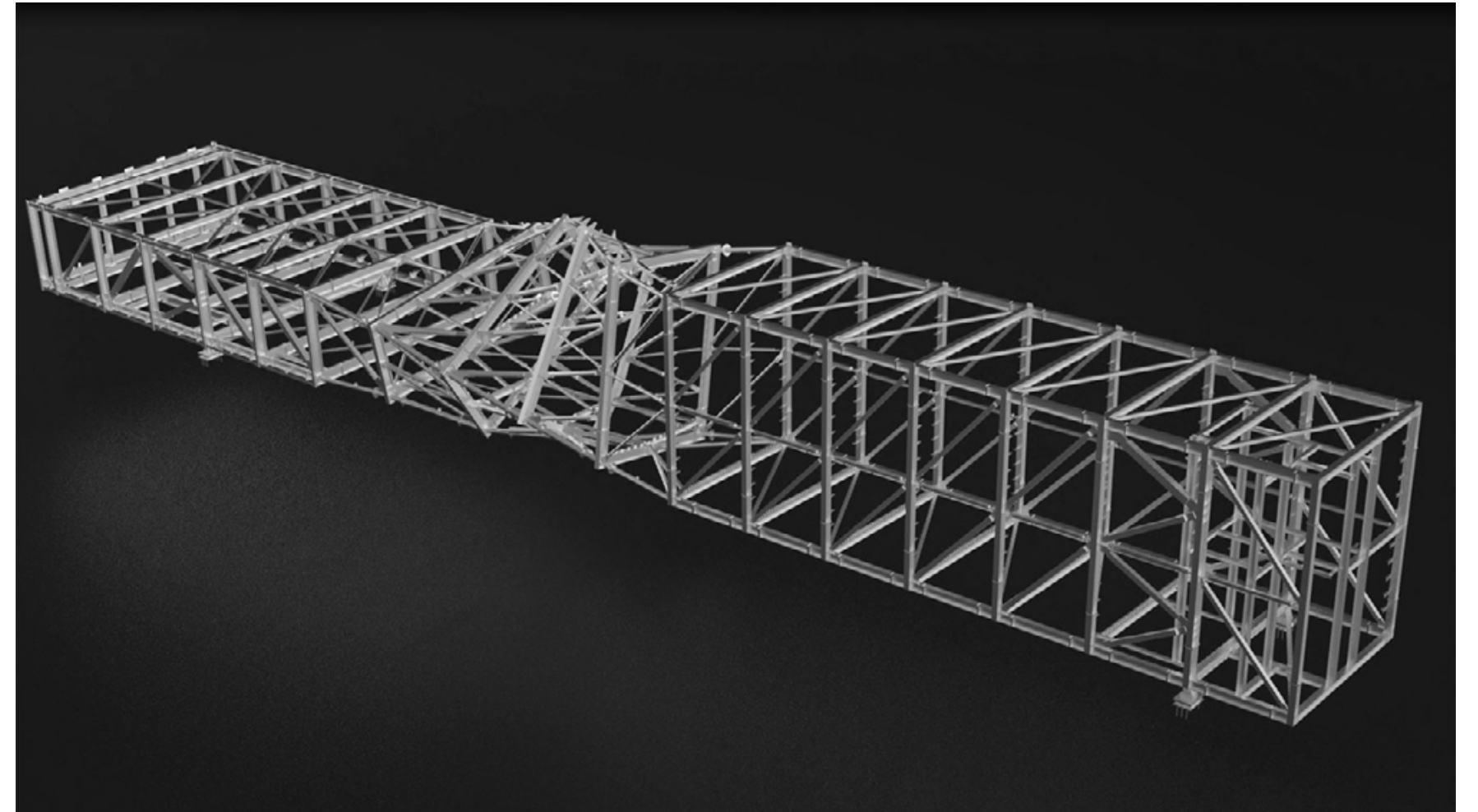
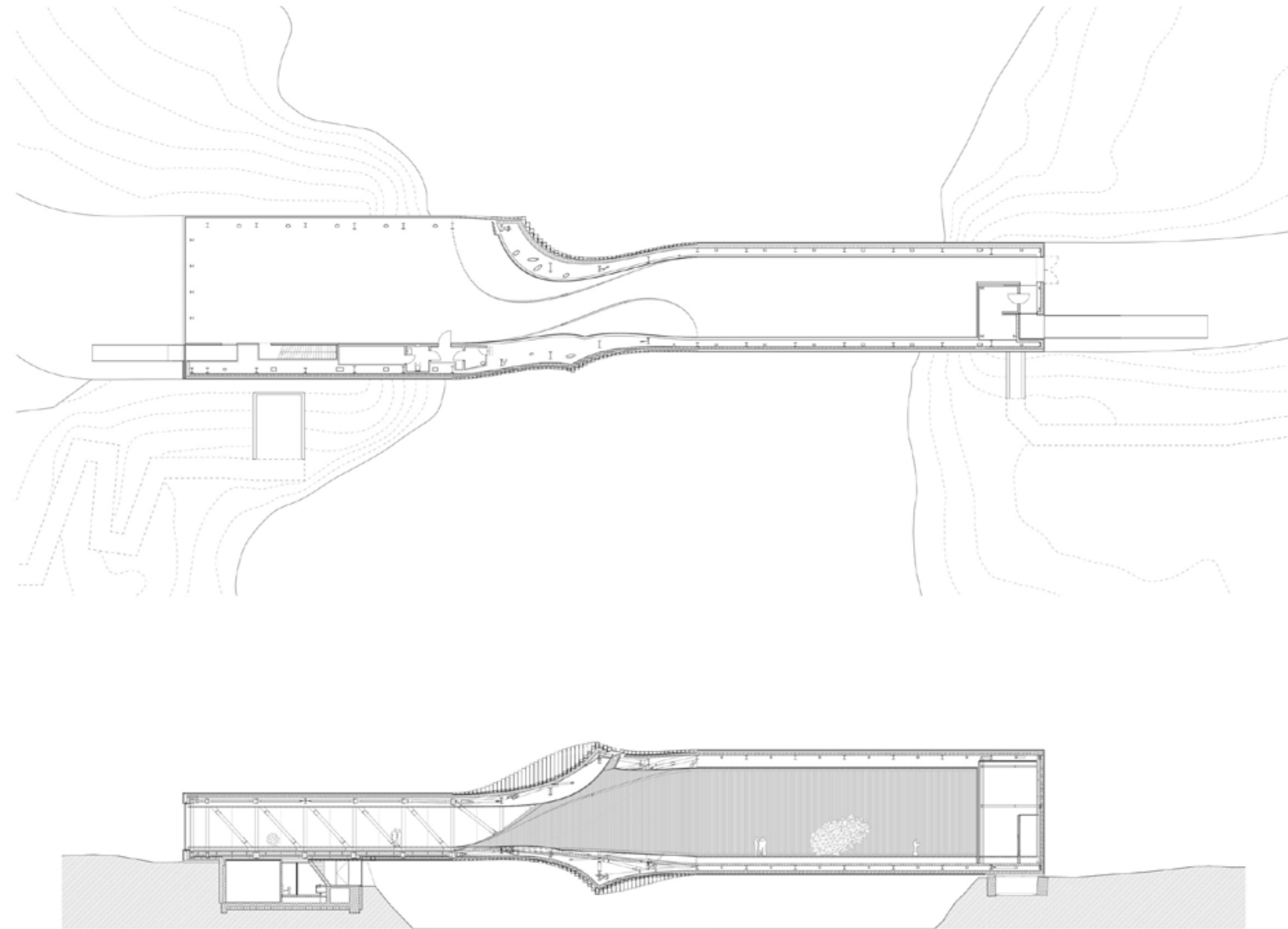

program

Spatial composition, Organization and Sequence of spaces.

Roman Bathhouse

In Roman baths, there was a prescribed ritual to follow, where the users would transition from cold to hot spaces. The sequence of the spaces is as follows: dressing room, cold bath, warm bath, hot bath, and in the end the steam bath. After the steam bath, they spent time socializing at the outdoor pool.

- 1 - Entrance (dressing room)
- 2 - Cold bath (Frigidarium)
- 3 - Pool (Natatio)
- 4 - Gym (Palestra)
- 5 - Warm Bath (Tepidarium)
- 6 - Hot bath (Calidarium)
- 7 - Sweat room (Laconicum)

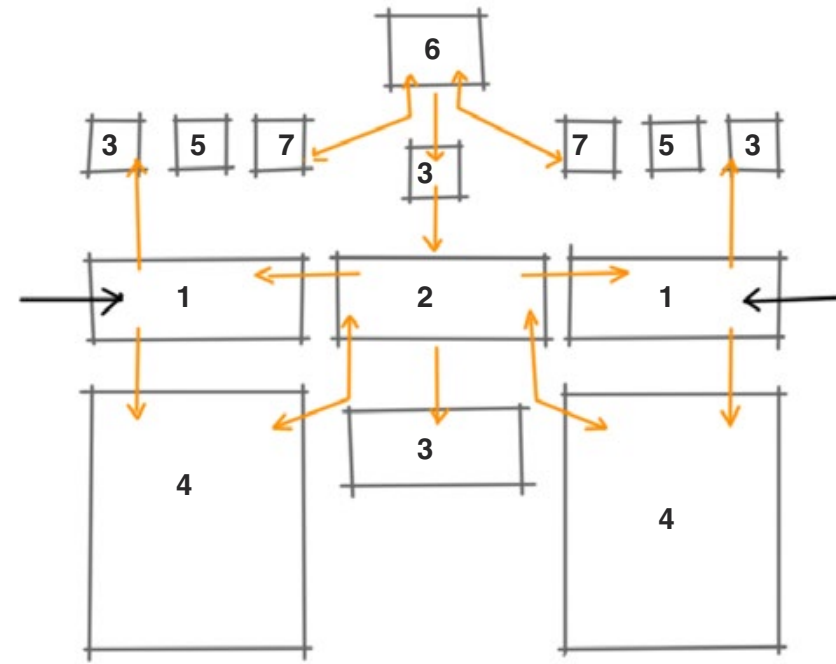

Turkish Hammam

In the Islamic baths, there is no cold bath and swimming pool. Instead of a swimming pool, the bathers use running water to clean themselves. The sequence of the spaces follows a gradual increase in temperature.

- 1 - Changing Room
- 2 - Warm Room
- 3 - Hot Room
- 4 - Bathing room

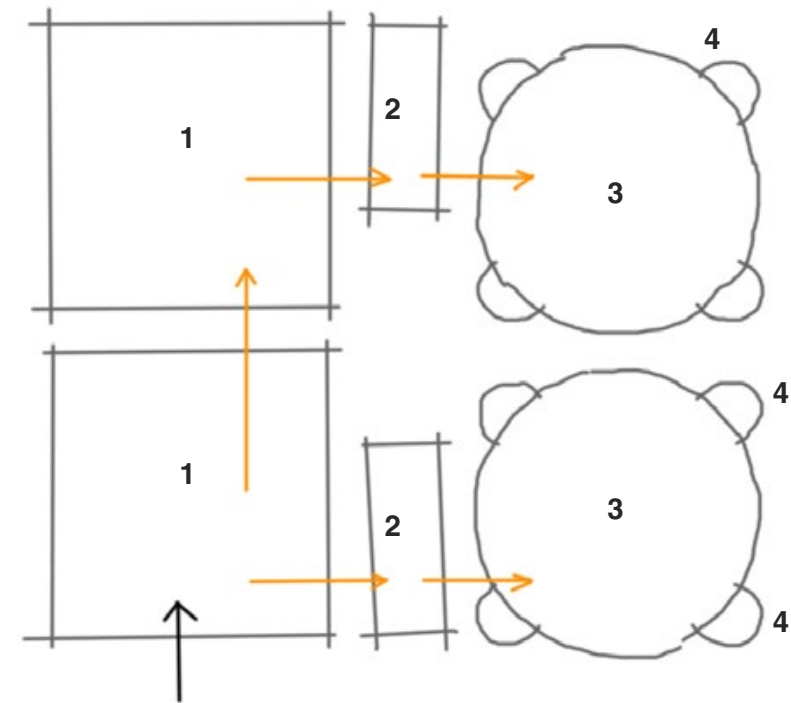

Therme Vals, Contemporary

There is not a defined sequence of spaces. Once you enter, a narrow corridor directs you to the locker rooms and showers. After the showers, people are free to explore the rest of the spaces at their own pace. The program provides a mix of private and public spaces inside.

- 1 - Changing Room
- 2 - Special baths
- 3 - Toilets
- 4 - Turkish Shower
- 5 - Fire Bath
- 6 - Outdoor Bath
- 7 - Indoor Bath
- 8 - Rest Area

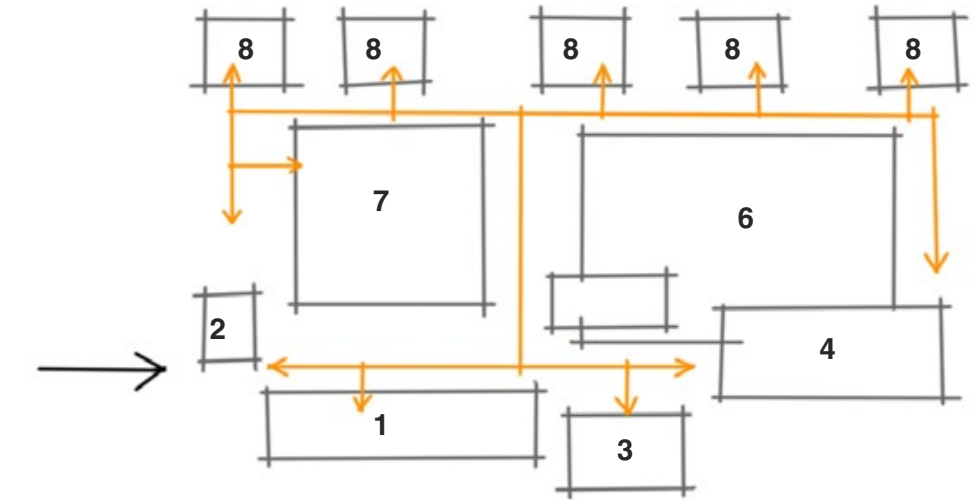

Program / Proposal

The program will offer different types of baths. It will have a similarity to Therme Vals in Switzerland. After the Showers, the visitors will feel free to explore other areas, without a prescribed ritual.

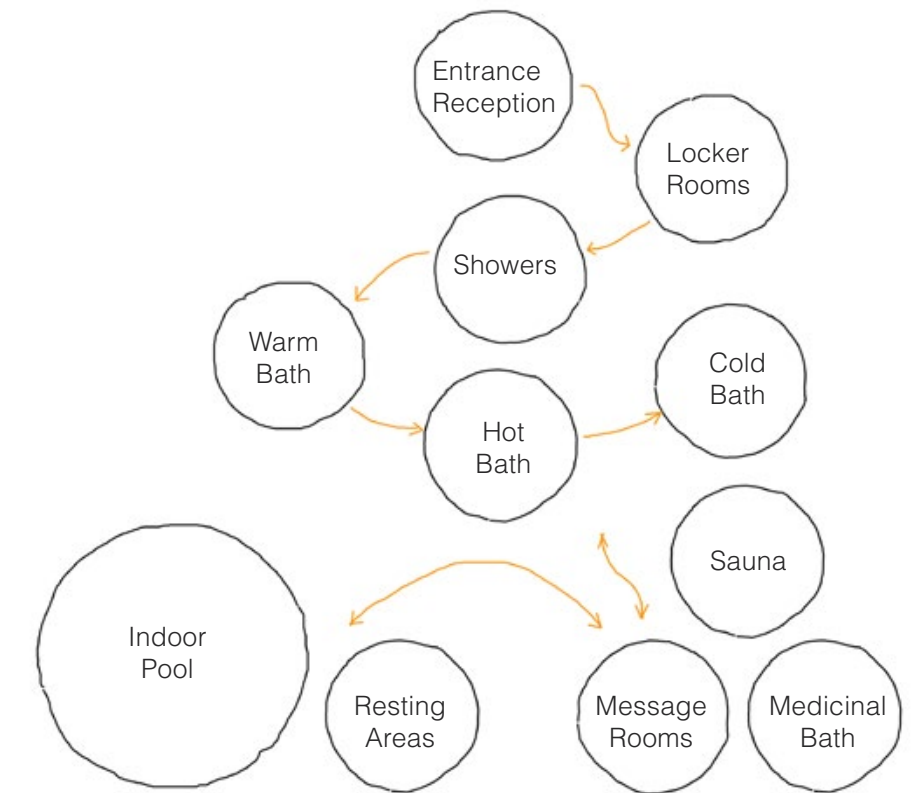

program

Space diagram

Main spaces of the Bathhouse divided in 5 categories:

- 1 Main Social Zone
- 2 Female zone
- 3 Male zone
- 4 Lobby
- 5 Administration

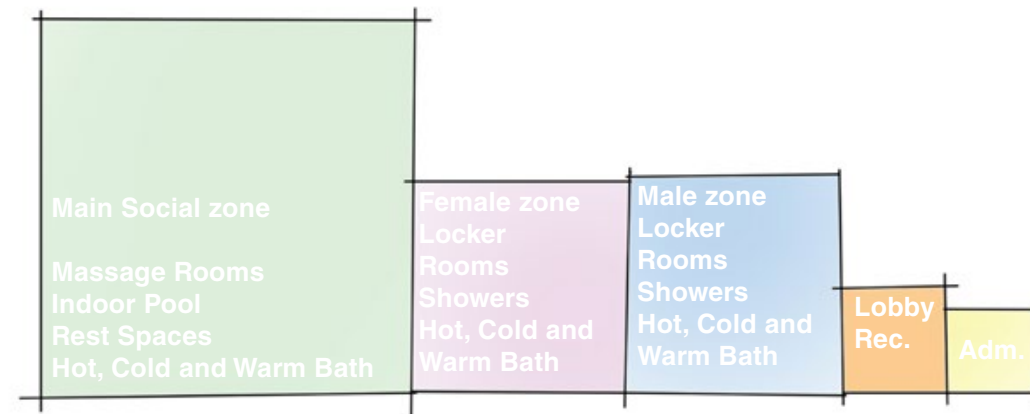

Typical distribution of the spaces.

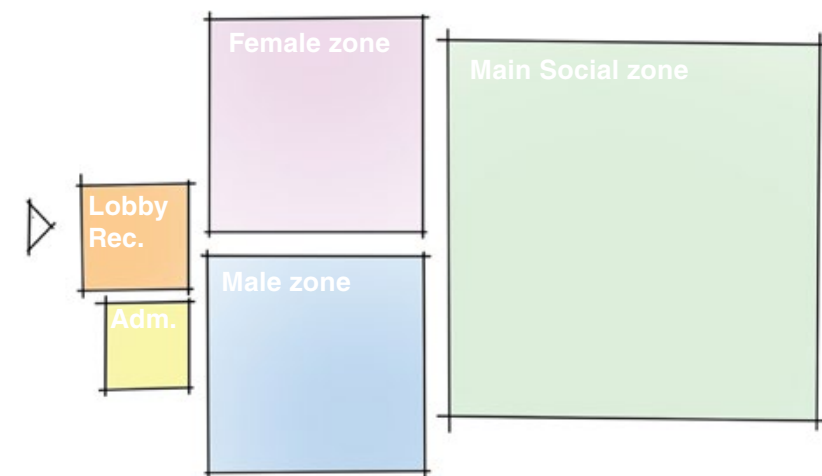

Advantages + / - Disadvantages

Option 01

- + Accessibility
- + Circulation
- Visual Connection
- Interaction
- Organization of Spaces.

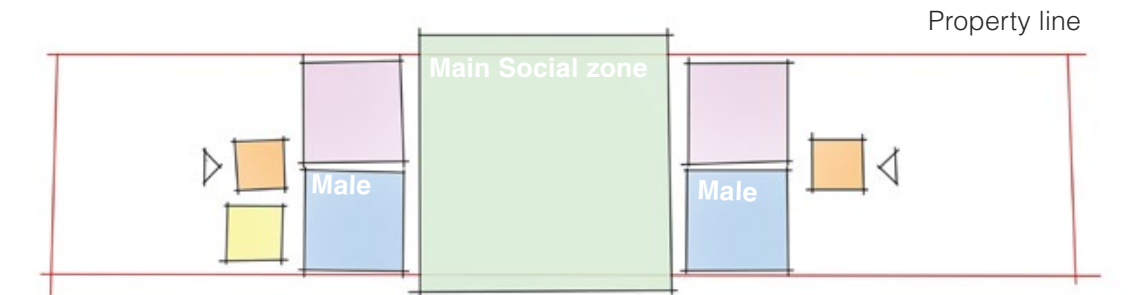

Option 02

- + Accessibility
- + Visual Connection
- Organization of Spaces.
- Circulation

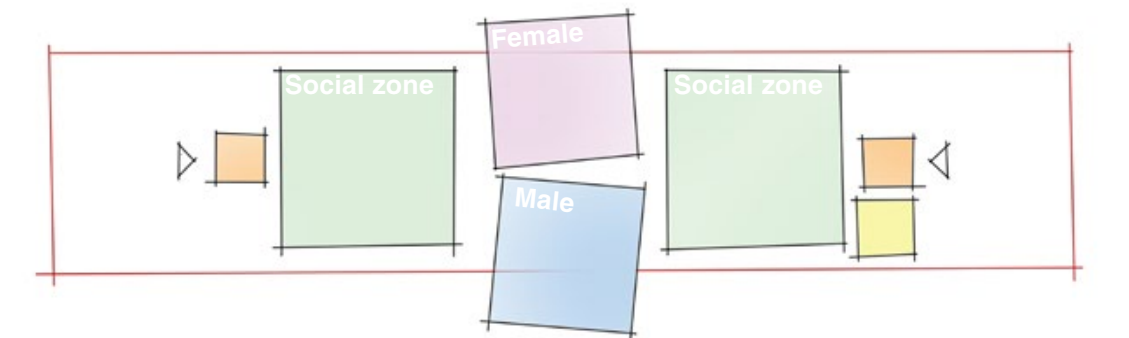

Option 03

- + Organization of Spaces
- + Circulation
- + Visual Connection
- Accessibility

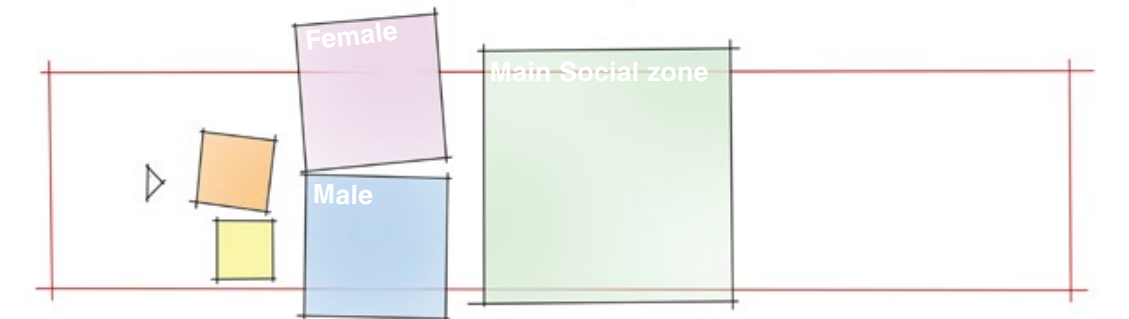

Option 04

- + Accessibility
- + Circulation
- + Organization of Spaces.
- + Visual Connection
- + Better experience

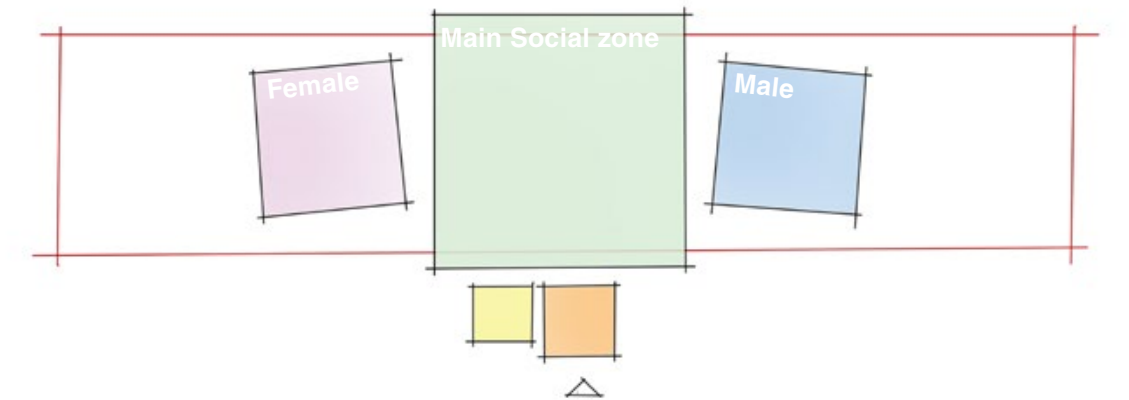



part III

Site Photos	44
Concept	45
Materials	47
Design Exploration	49
Site Plan	53
Section	59
Enclosure	65
Exploded diagram	67
Floor plans	69
Sections	75
Hot Cold Warm	85
Structure	95
Roof Plan	97
Details	99

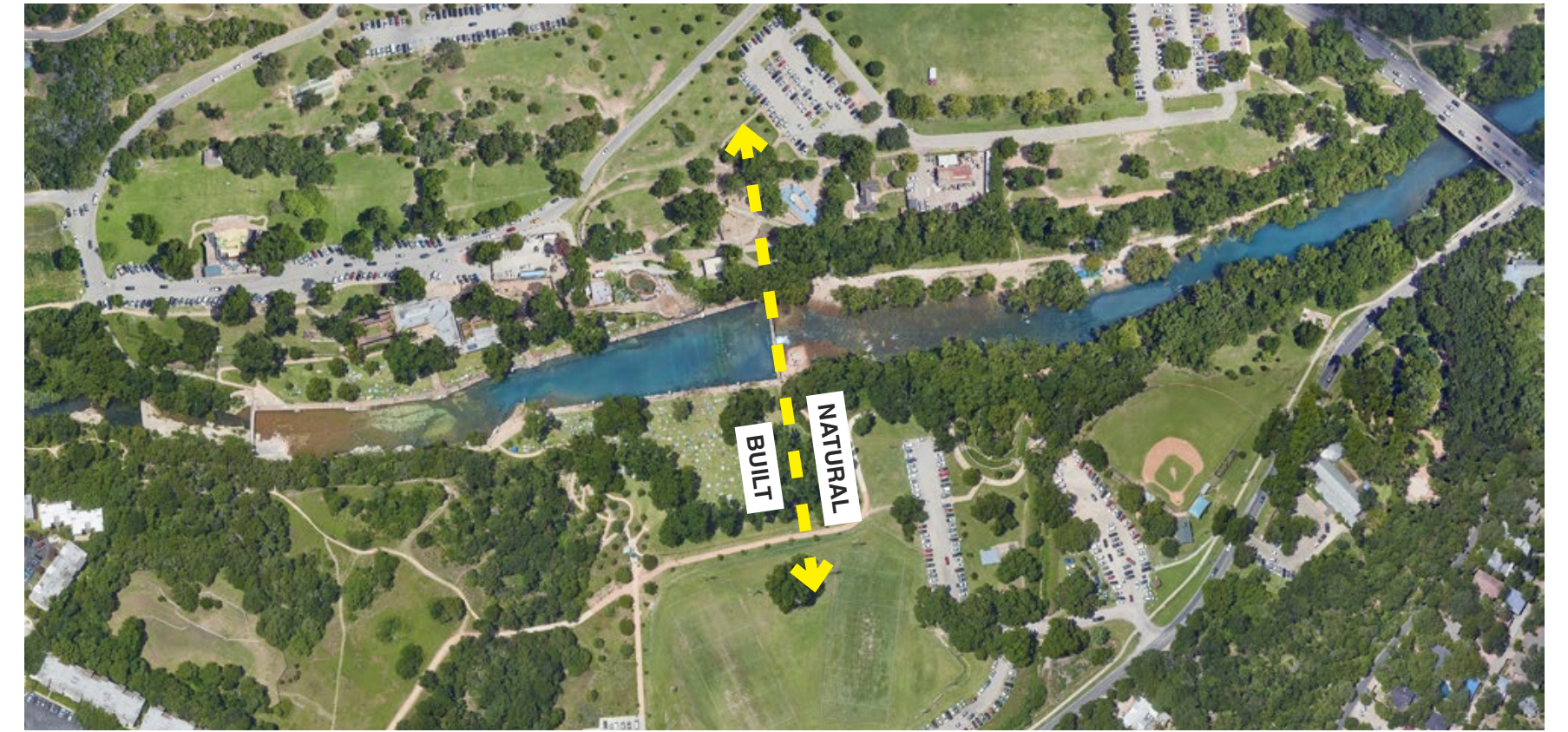
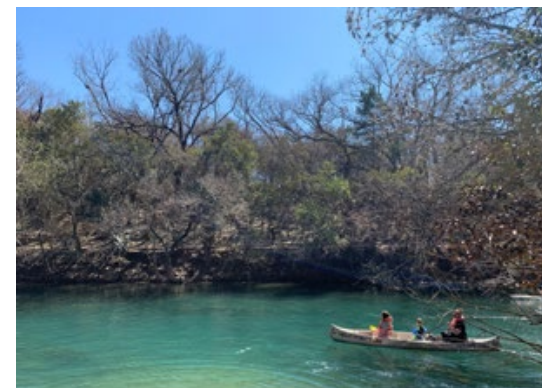

Barton Springs Pool, Zilker Park



the edge

Choosing where the connection is better to happen, was dictated by the existing conditions.

Barton Springs pool was built in 1929 and is an outdoor swimming pool, located within the channel of Barton creek. There are two dams that define the space of the pool, at the same time being the edges between the pool and the creek.

The edge between the Barton Springs pool and Barton creek, allows for better accessibility and does not disrupt any ongoing activities happening on site.



concept

The concept started from site analysis, as a need to connect the North and South landscape. The idea of having a pedestrian Bridge, which can serve to the Public, and proposing the Bathhouse on top of it. In this way these programs will coexist together. The goal was not only to connect these two sides, but also to create a meaningful experience for the users and the community crossing from one side to another. For a better program distribution we located the entry point in the middle of the pedestrian bridge. Lastly, an important element was to bring natural daylight from the top for the main spaces of the Bathhouse.

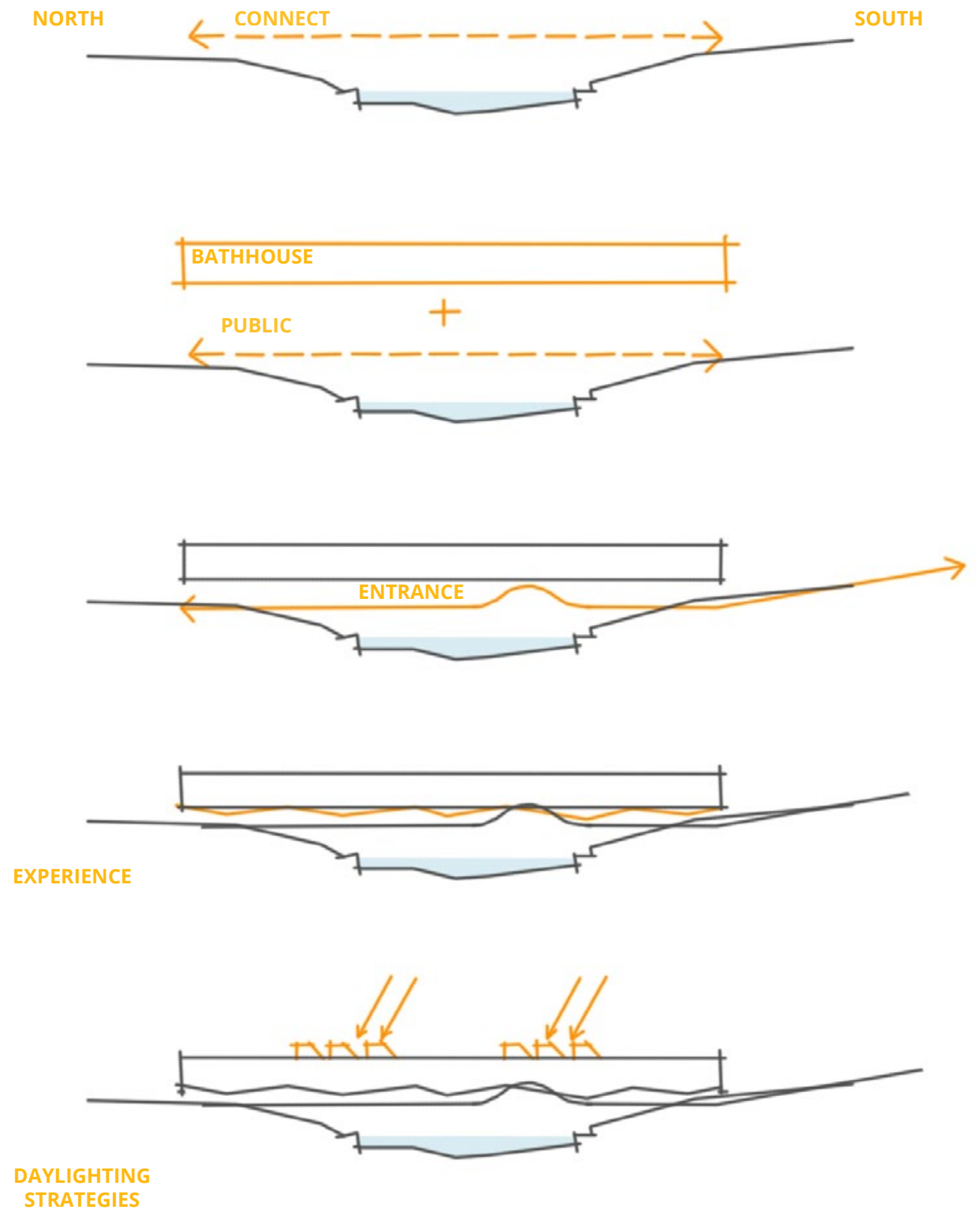

materials

A combination of stone, steel and glass. For the structure is proposed Recycled Steel, which offers long span and allows the members to be more elegant. In the exterior, to create a seamless effect, there are proposed three different types of glass. The transparent, translucent and opaque glass. The translucent glass can provide at the same time acoustical and visual privacy, while can offer diffused light and also a pleasant effect during the night. Throughout the history, a common material in the bathhouse is the stone, so for the interior is used non polished Marble. A natural material, from the past with a contemporary feel.



structure

Recycled Steel



enclosure

Translucent, transparent and Opaque Glass

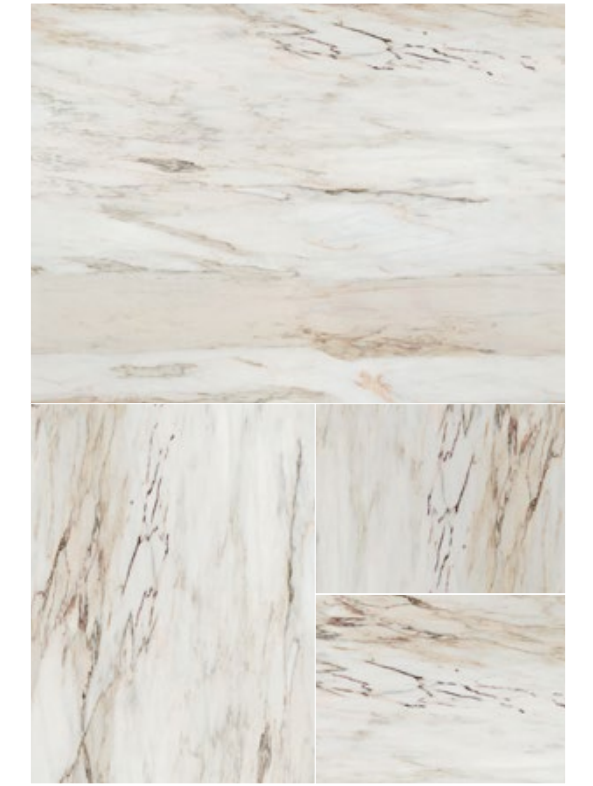

interior

Non Polished Calacatta Marble

design exploration

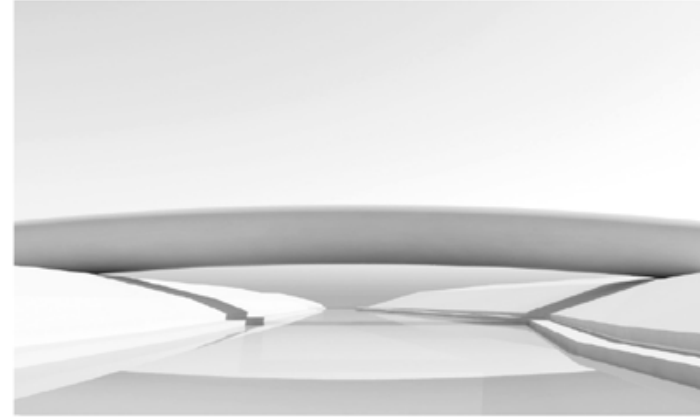

bending, pedestrian and bathhouse same level

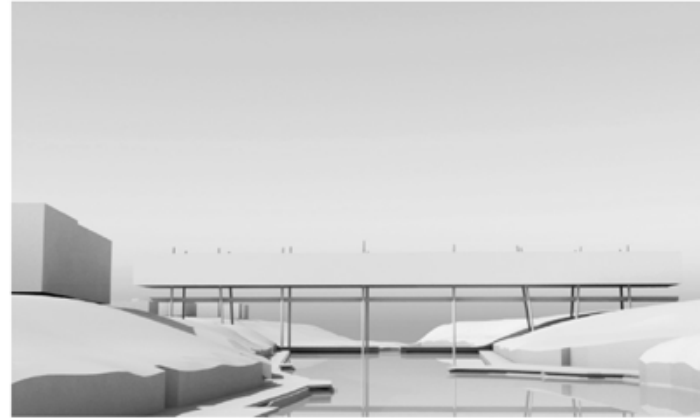

column support

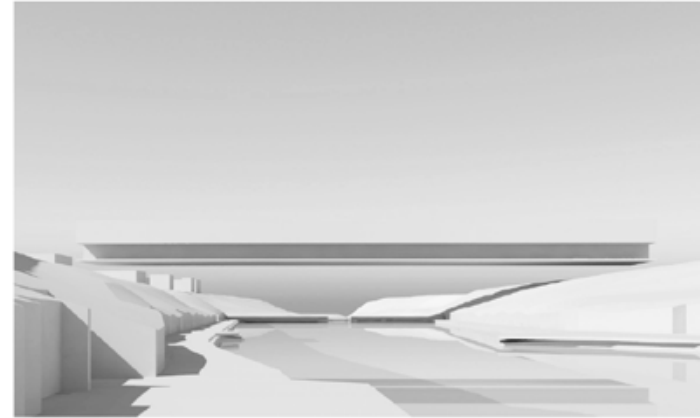

pedestrian and bathhouse same level

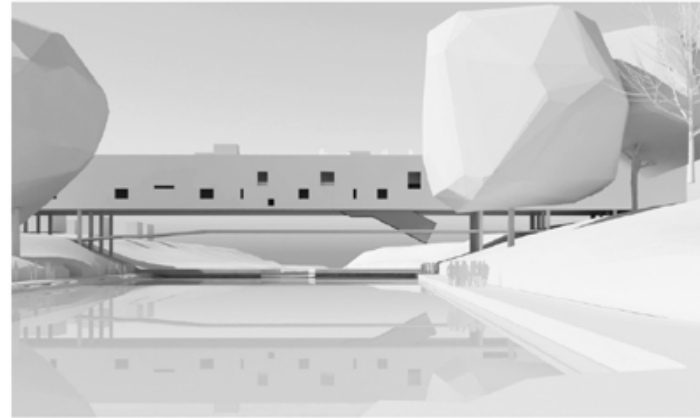

exterior openings

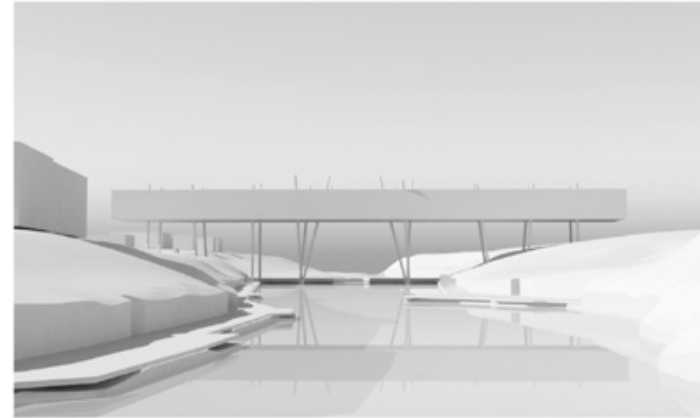

column support

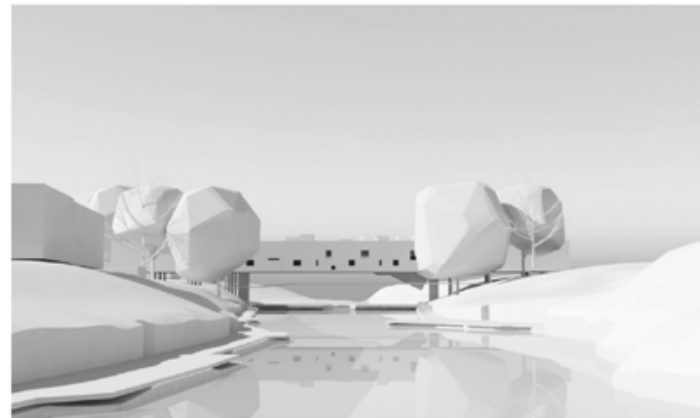

connecting at the ground level



connecting at the ground level

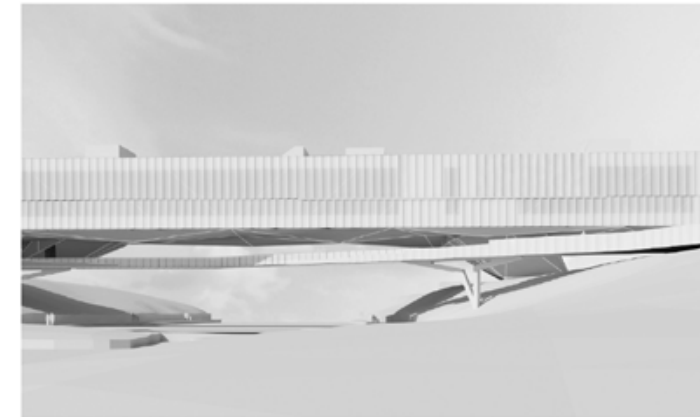

view from barton creek

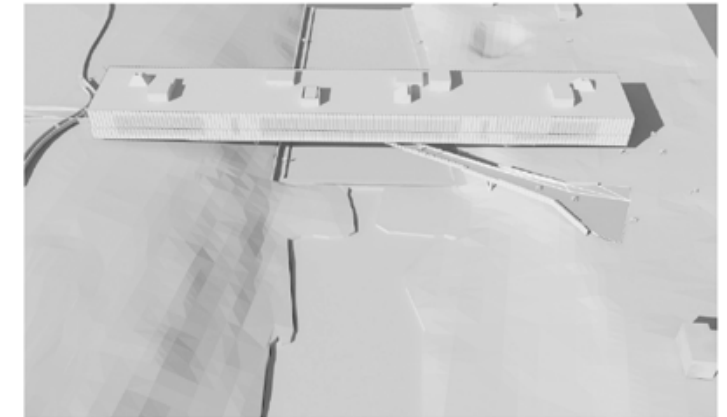

top view

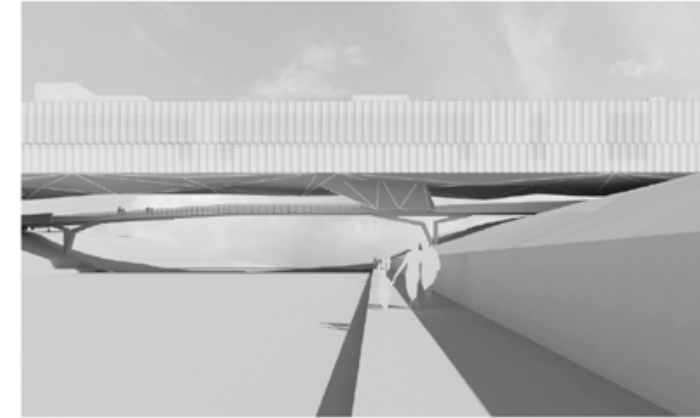

view from barton springs pool



view from north landscape

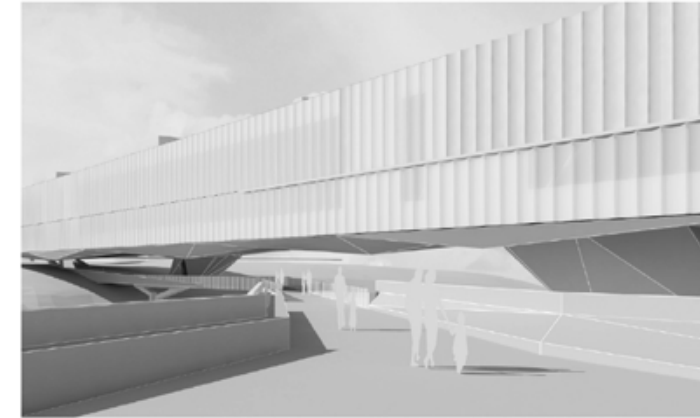

north entrance

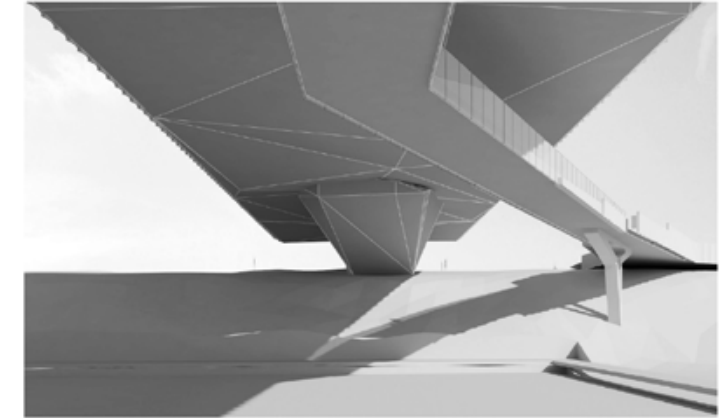

view from barton springs pool

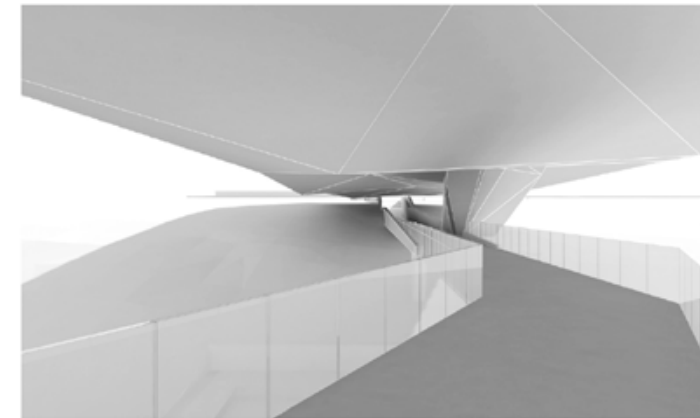

under the building

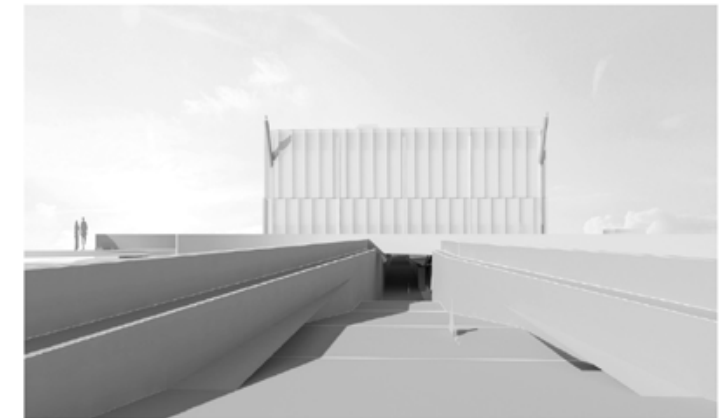

south entrance

body of architecture

The structure is perceived as an important element of the design. Instead of hiding it, I wanted to celebrate it in the interior and the exterior.

material compatibility

Due to its context, in the exterior it was important that the building transmits a sense of lightness & softness. For this reasons, glass was chosen as a primary material. The main characteristic of glass is transparency, and to adress different programmatic needs, I played with the level of transparency. Three different types of glass come together to enclose the building.

View from the Barton Creek



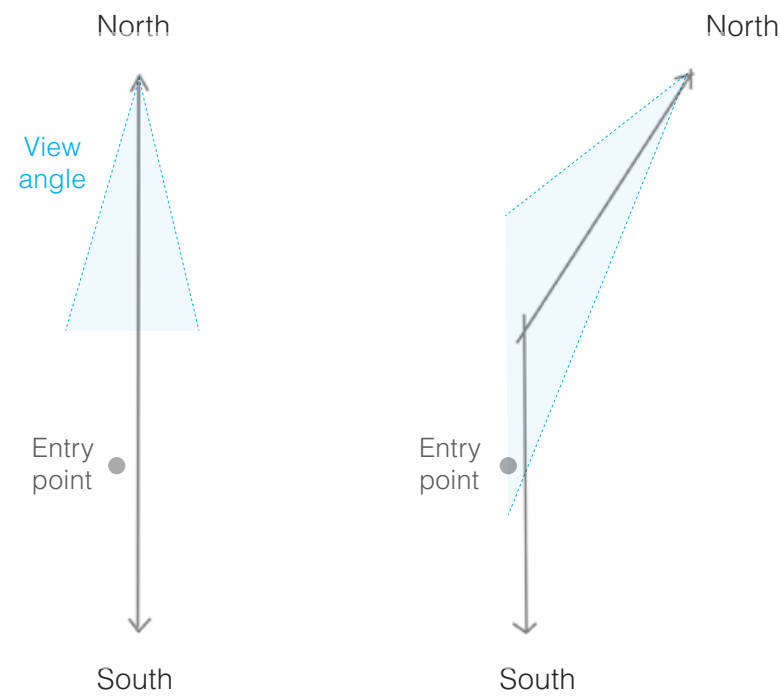

site plan

The site has a very good accessibility. It is a pedestrian friendly zone. People can visit the site by car, bicycle, or public transportation too. There are three entry points for the pedestrian bridge, One in North and two from South. In this way, I wanted to make sure that all the existing trails connect to these access points.

- 1 North Entry Point
- 2 South Entry Point
- 3 Main Entrance
- 4 Exit Stairs
- 5 Parking
- 6 Bus Station
- 7 Existing Bathhouse
- 8 Bike parking
- 9 Barton Springs Pool
- 10 Barton Creek
- 11 Eliza Springs
- 12 Sunken Garden
- 13 Park Ranger Headquarters
- 14 Monkey Tree

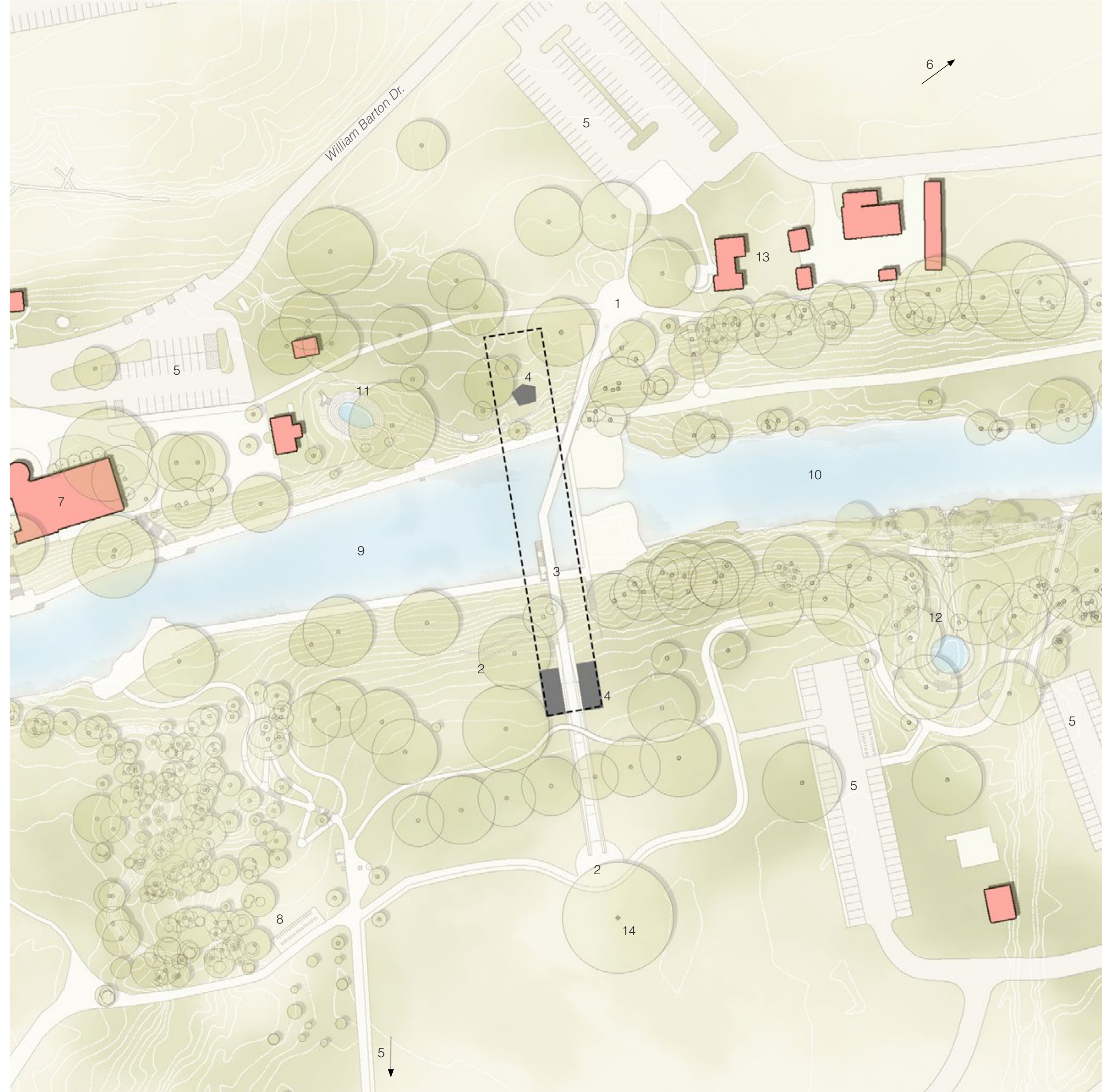
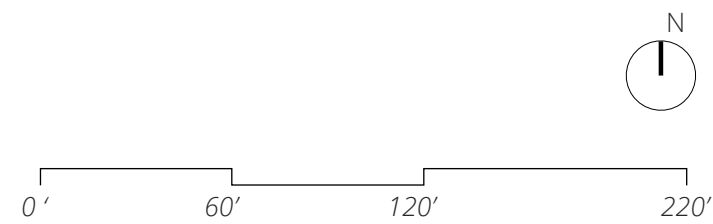

south entrance

The main goal was to create a sensuous experience for the visitors crossing from one side to another, while also inviting them to explore the bathhouse and start a new journey. Once approaching the bridge from the southern landscape, a ramp leads you under the building. In the front of the bridge, the visitors will be facing the short side of the building, a seamless translucent glass façade, where the visible structural elements are in the back of the exterior enclosure. After the steel structure, the wall is painted white to enhance the effect of the glass.

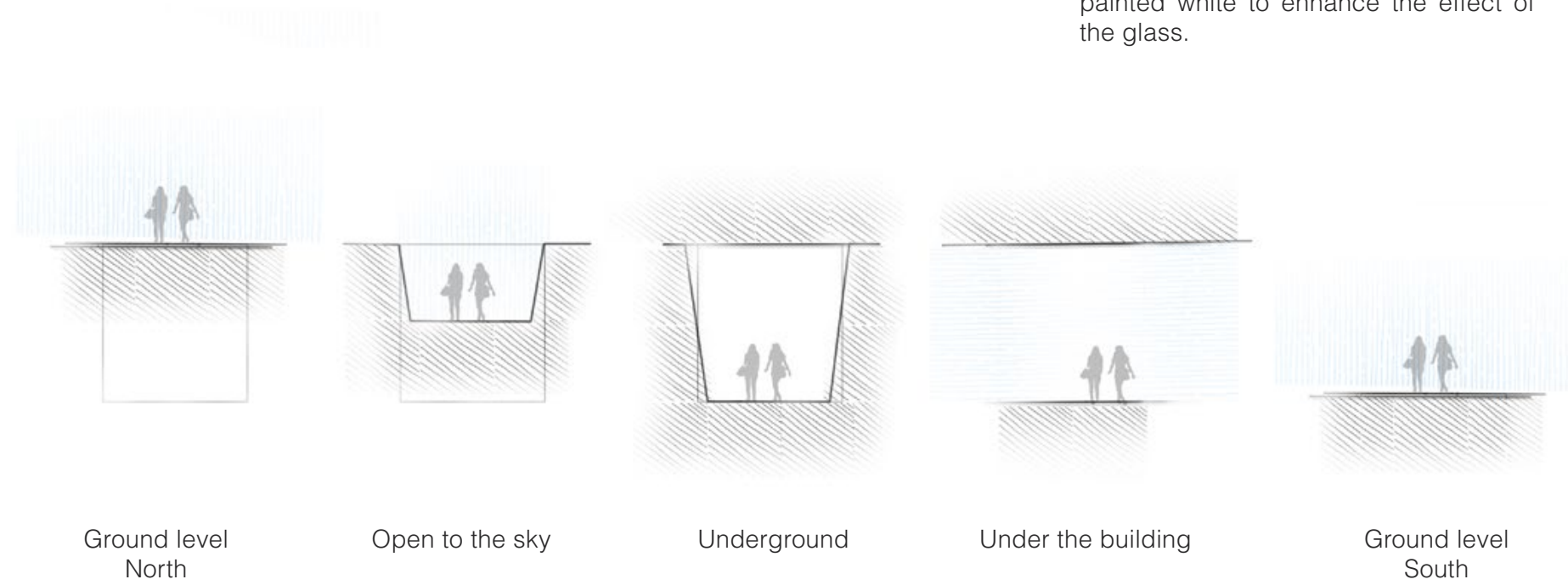

where the building meets the ground

Because the site has a difference in elevation from North to South landscape around 13 feet, the building foundation, on the South sits on the ground, while on the Northern part it is proposed a concrete abutment.

The use of triangulated polished steel cladding helps in minimizing the visual impact on site while also creating a continuous play with the reflected landscape.

View from the northern landscape

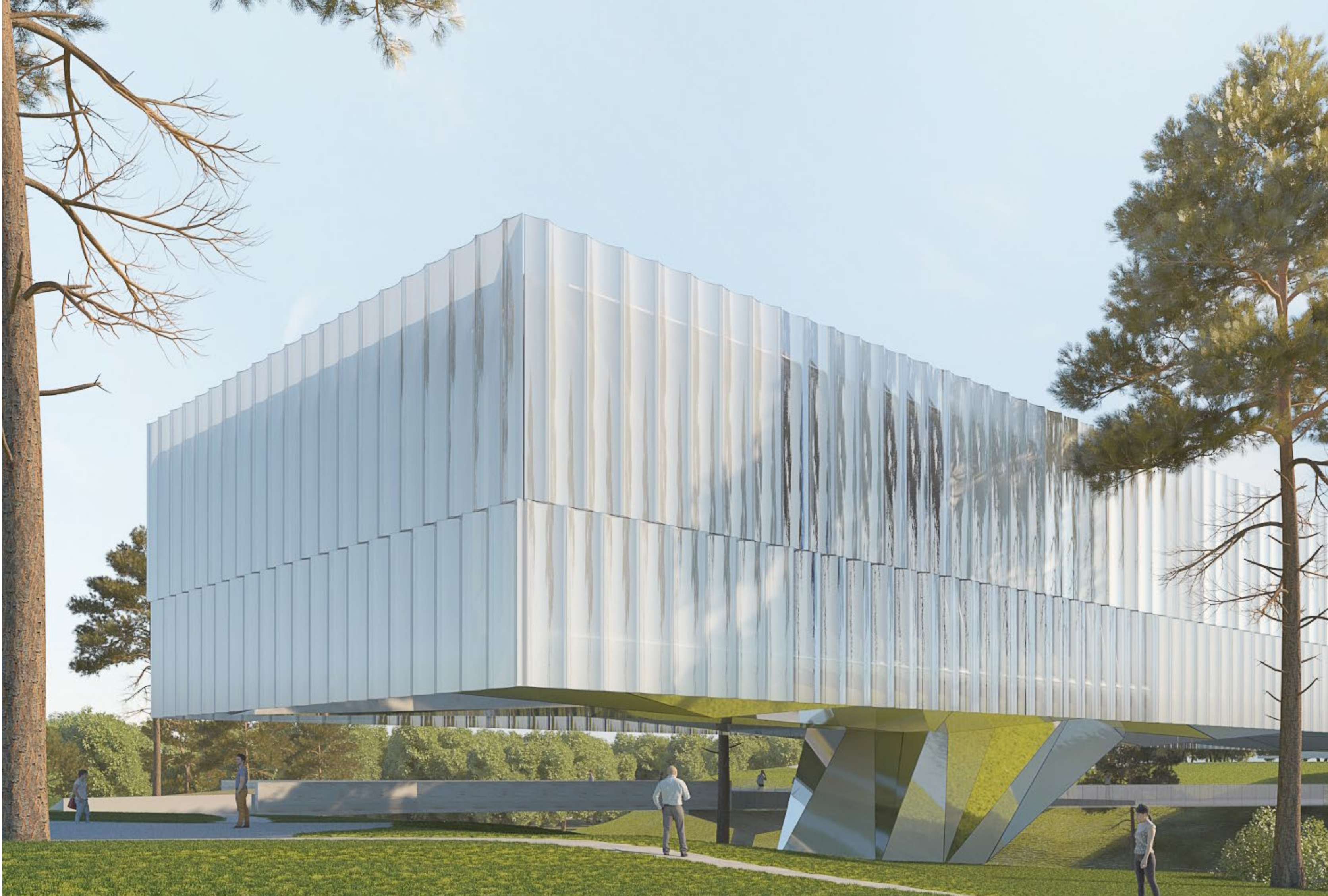

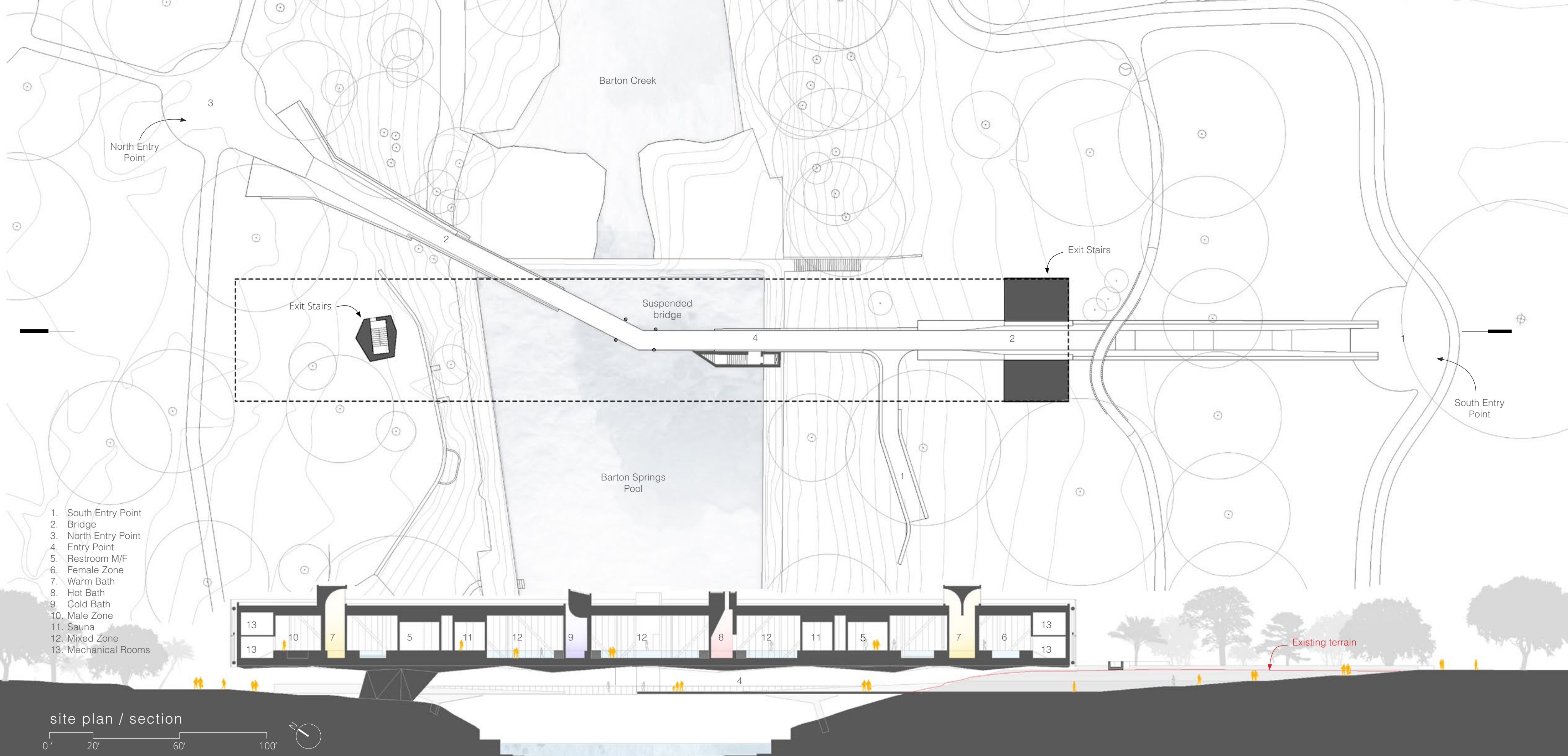

Barton Creek

Barton Springs Pool

North Entry Point

South Entry Point

Exit Stairs

Exit Stairs

Suspended bridge

Existing terrain

- 1. South Entry Point
- 2. Bridge
- 3. North Entry Point
- 4. Entry Point
- 5. Restroom M/F
- 6. Female Zone
- 7. Warm Bath
- 8. Hot Bath
- 9. Cold Bath
- 10. Male Zone
- 11. Sauna
- 12. Mixed Zone
- 13. Mechanical Rooms

site plan / section

0' 20' 60' 100'



north entrance

Once you approach the bridge from the northern landscape, the building unfolds toward you on one side, while on the other side you can see the city skyline. The path allows you to see the Bathhouse entry point, located in the middle of the bridge, in this way inviting you to start a new experience. The large span structure gives the impression that the building is floating in the air while not preventing the visual connection at the eye level.

View from the northern landscape



concave concept

The exterior of the building is treated with two continuous concave laminated glass panels, which are shifted from one another to create a sense of movement. As in classical columns, the concave element adds more to the verticality of the object. Moreover, the two panels reduce the overall scale of the building and help in creating a better connection with the human scale.

Lastly, the concave element makes possible to create shadows in the exterior that would not been possible with a flat glass. In this way creating a continuous play of light and shadow during the day.



enclosure

The exterior of the building is wrapped by two continuous concave glass panels. These panels are suspended from stainless steel bracket cantilevered off the main structure. For the interior is used another transparent glazing layer. The main steel structure 'lives' in between the interior glass and exterior curved panels. This cavity acts as a double skin facade for the building so that it does not overheat.

Moreover, the exterior curved glass are made of different transparencies to respond to programmatic needs. The top panels are mostly opaque and translucent, which keeps the privacy and at the same time serve as a shading elements. Whereas at the bottom part is used transparent glass to allow for visual connection with the exterior.

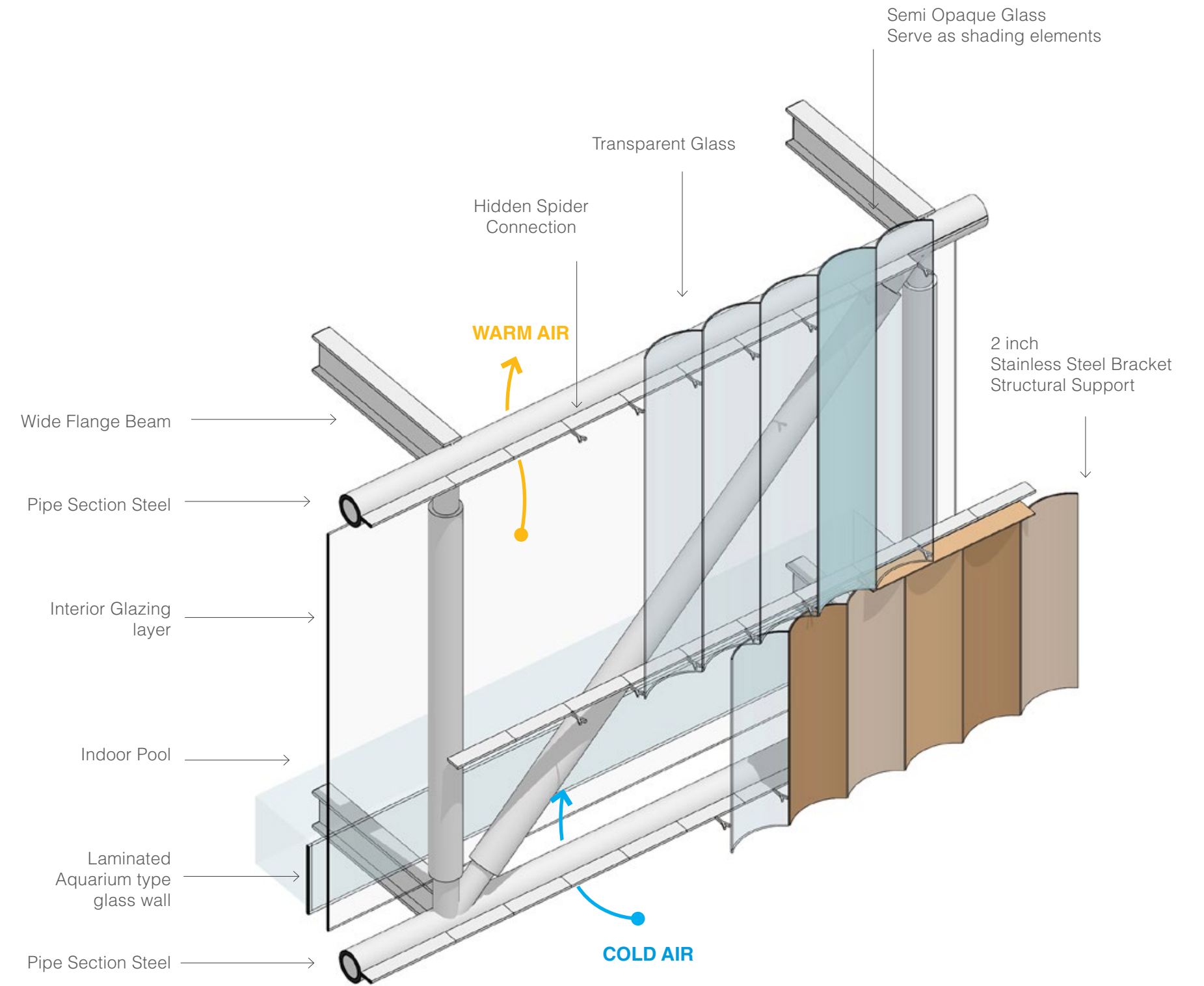
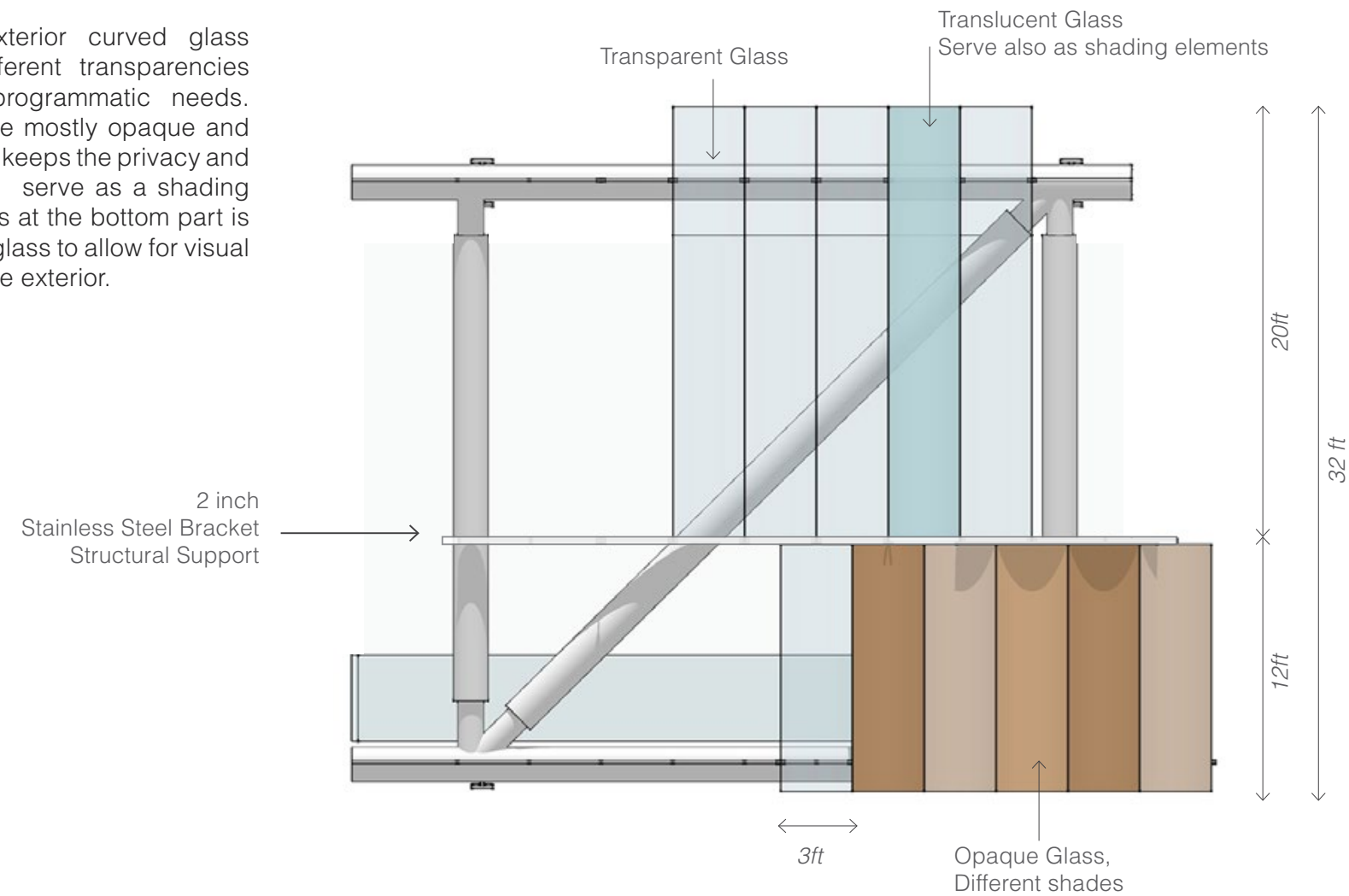
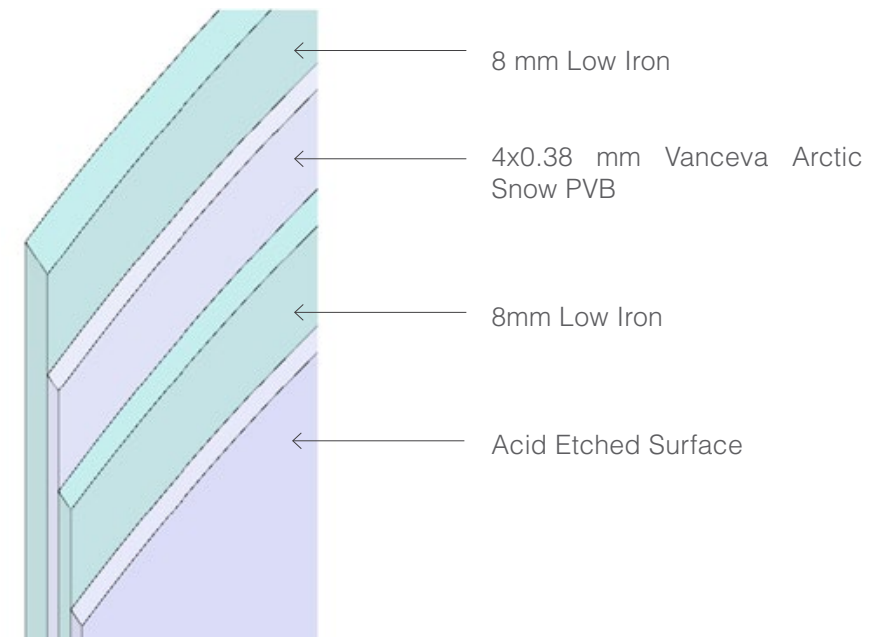

exploded diagram

- 9 Exterior Cladding
*Concave laminated Glass panels
Modular 3 foot in width*
- 8 Roof
- 7 Second Floor
Massage rooms + Rest spaces
- 6 First Floor, spaces
Bodies of water shown in blue. Other areas are used as mechanical spaces.
- 5 First Floor
- 4 Steel Truss Structure
- 3 Bridge Ceiling Design
- 2 Abutments
- 1 Suspended Bridge
- 0 Existing site

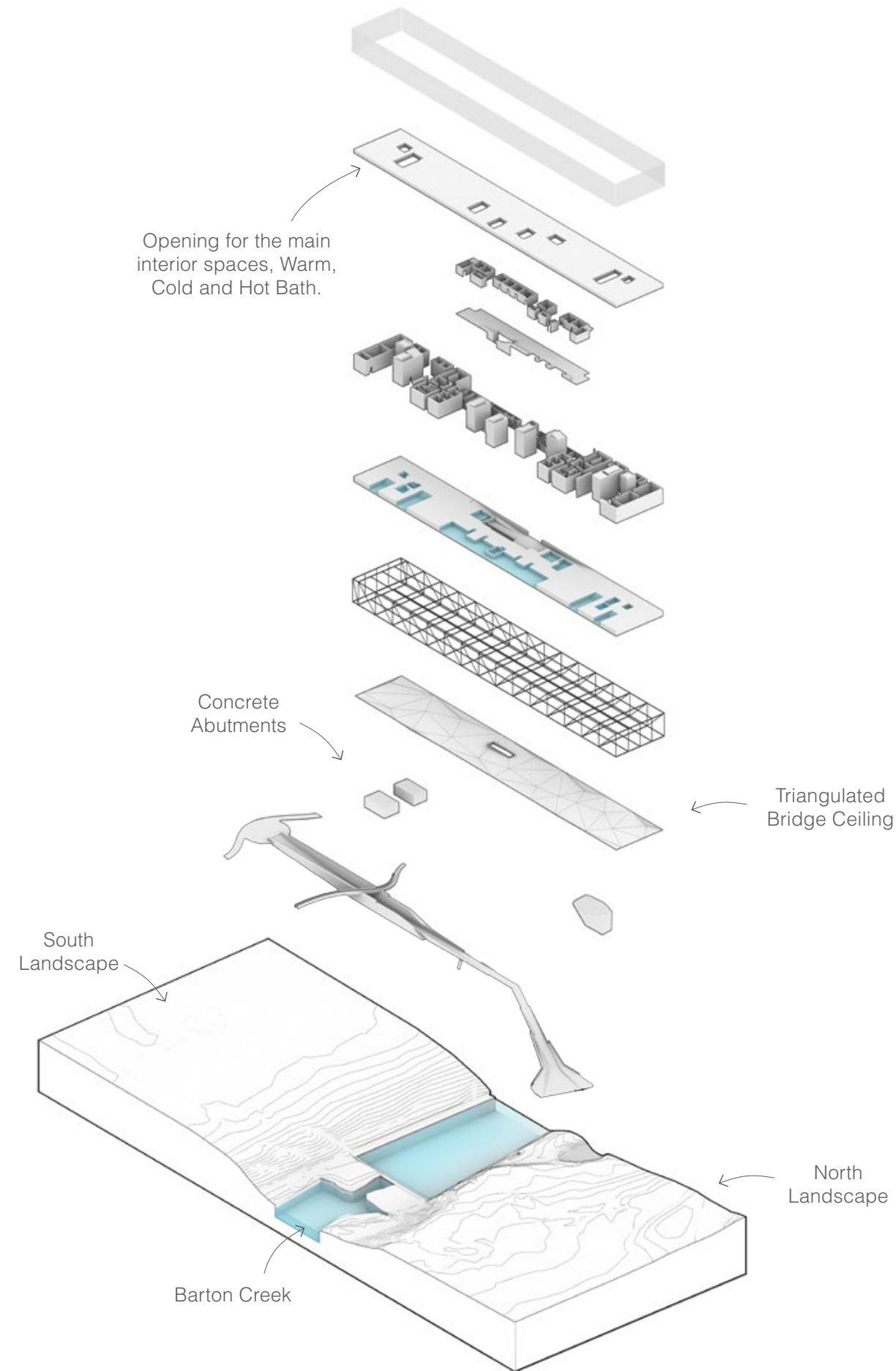

space layout and circulation

To respond to different cultures, the program is divided in private and mixed zones. The private areas are in each side of the building while the mixed zone is located in the middle to provide the best view.

The circulation diagram is simple. The entry point is located in the center of the Bathhouse. After the reception, males and females will take different corridors to access the locker rooms, showers and restrooms. After these spaces, they can spent time in private or mixed zone.

One interesting element in the design, was to define the spaces without using to many doors. So, with the articulation and the thickness of the walls, it is made possible to save the privacy of each space and the temperature, by providing different pressure between the inside and outside of the rooms.

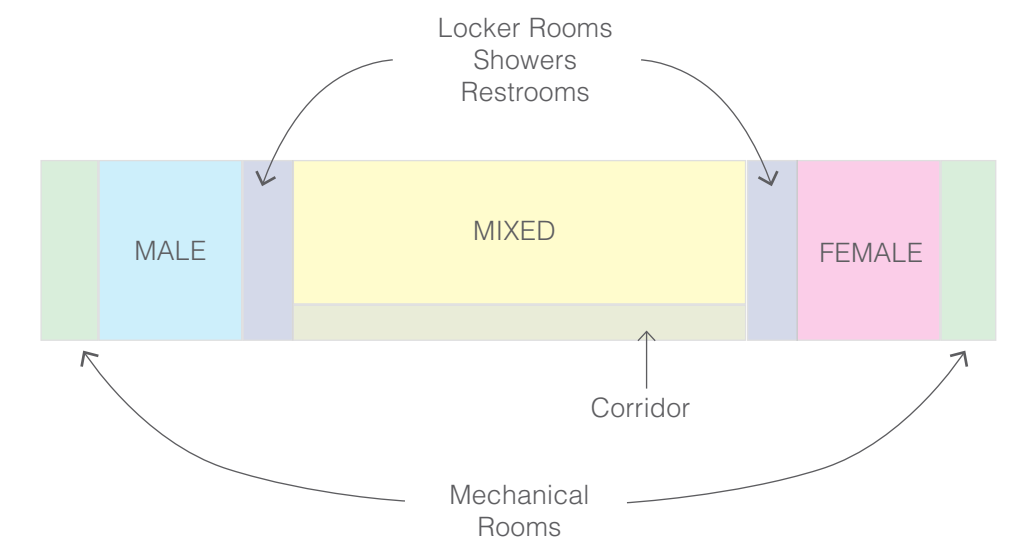
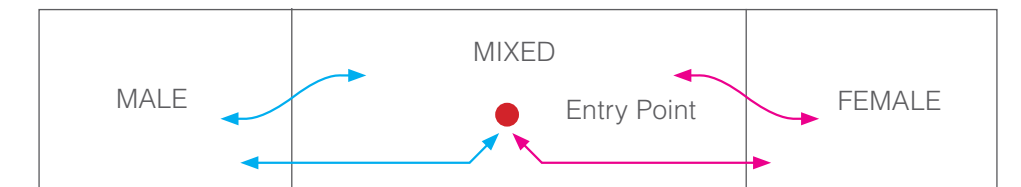
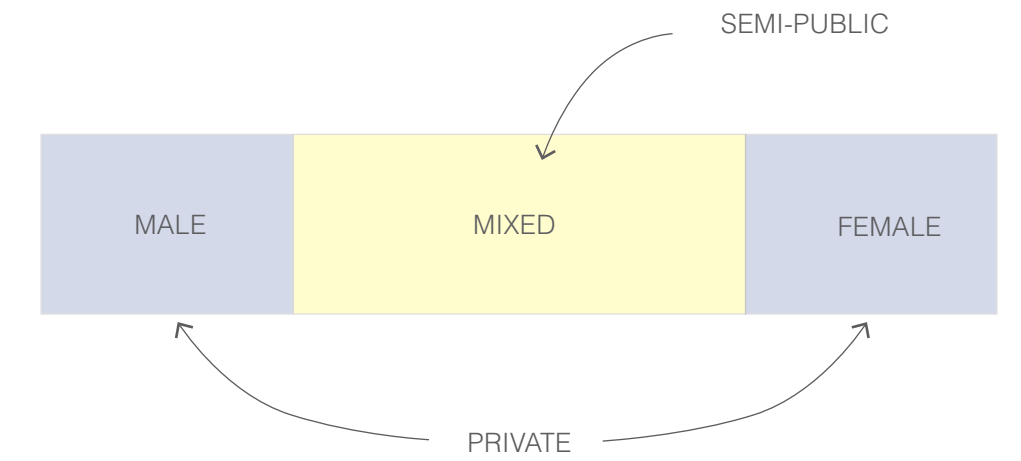



first floor plan



- | | |
|-------------------------|---------------------|
| 1. Entrance / Lobby | 9. Warm Bath |
| 2. Reception | 10. Fire Bath |
| 3. Elevator | 11. Cold Bath |
| 4. Staff/Administration | 12. Indoor Pool |
| 5. Staff Restroom | 13. Massage Room |
| 6. Locker Room Female | 14. Rest Spaces |
| 6'. Locker Room Male | 15. Sauna |
| 7. Showers | 16. Mechanical Room |
| 8. Restroom Female | 17. Mechanical Room |
| 8'. Restroom Male | 18. Exit Stairs |

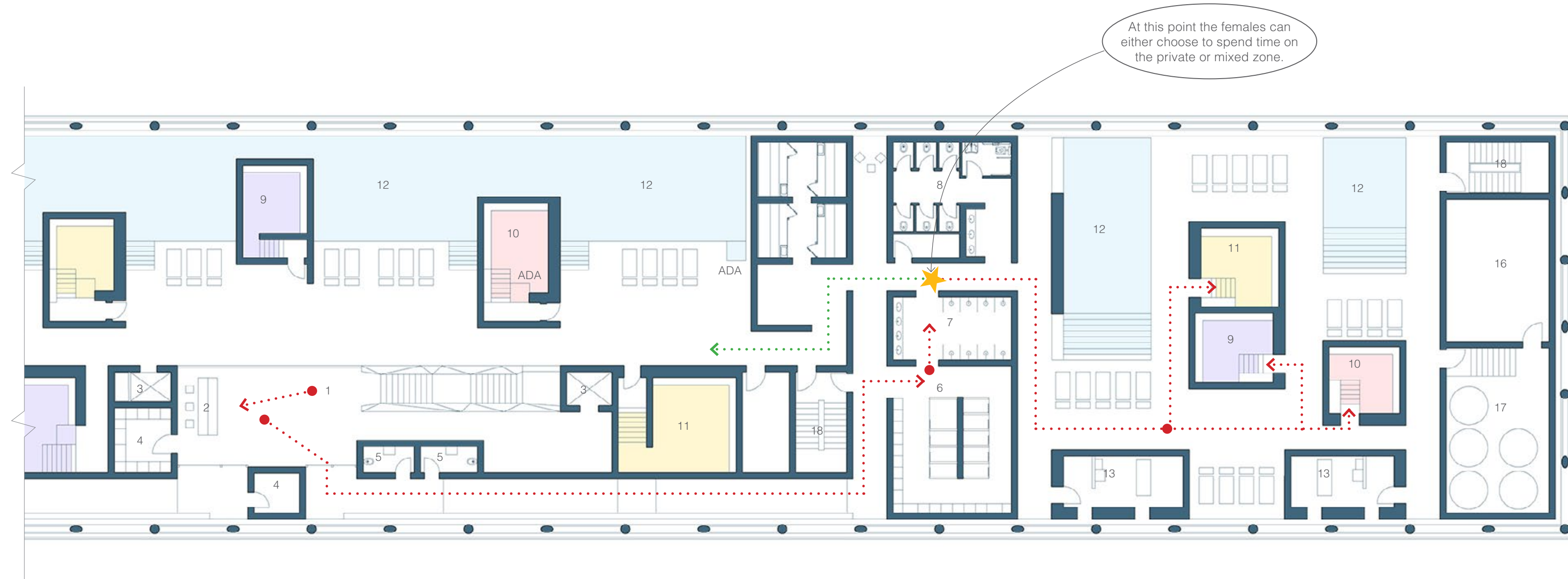

first floor / the sequence of spaces



- | | |
|-------------------------|---------------------|
| 1. Entrance / Lobby | 9. Warm Bath |
| 2. Reception | 10. Fire Bath |
| 3. Elevator | 11. Cold Bath |
| 4. Staff/Administration | 12. Indoor Pool |
| 5. Staff Restroom | 13. Massage Room |
| 6. Locker Room Female | 14. Rest Spaces |
| 6'. Locker Room Male | 15. Sauna |
| 7. Showers | 16. Mechanical Room |
| 8. Restroom Female | 17. Mechanical Room |
| 8'. Restroom Male | 18. Exit Stairs |

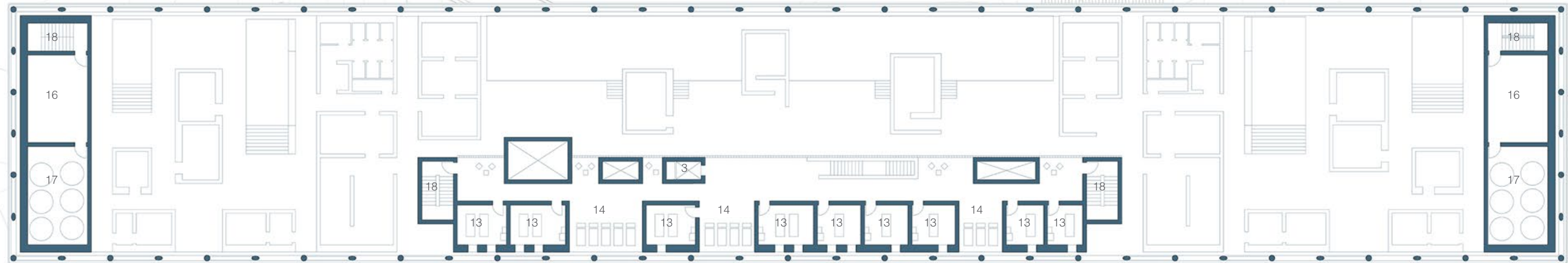

second floor plan



- 13. Massage Room
- 14. Rest Spaces
- 15. Sauna
- 16. Mechanical Room
- 17. Mechanical Room
- 18. Exit Stairs

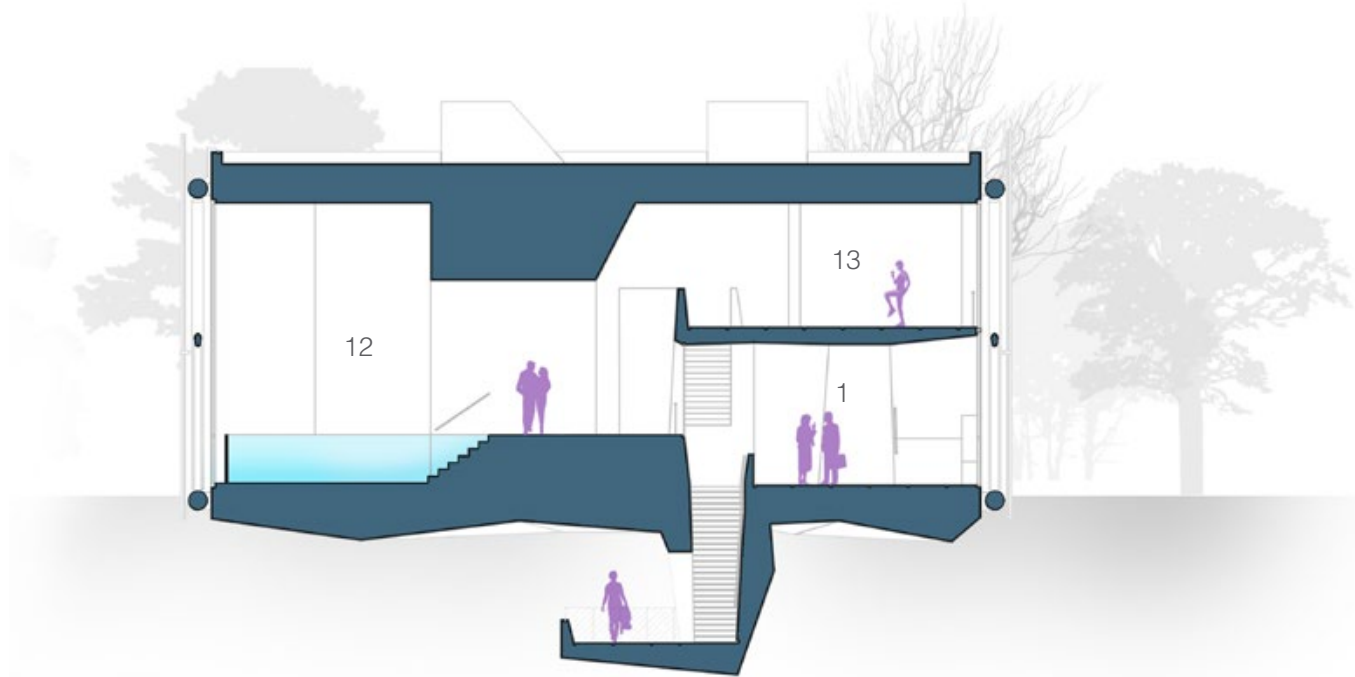

section a-a

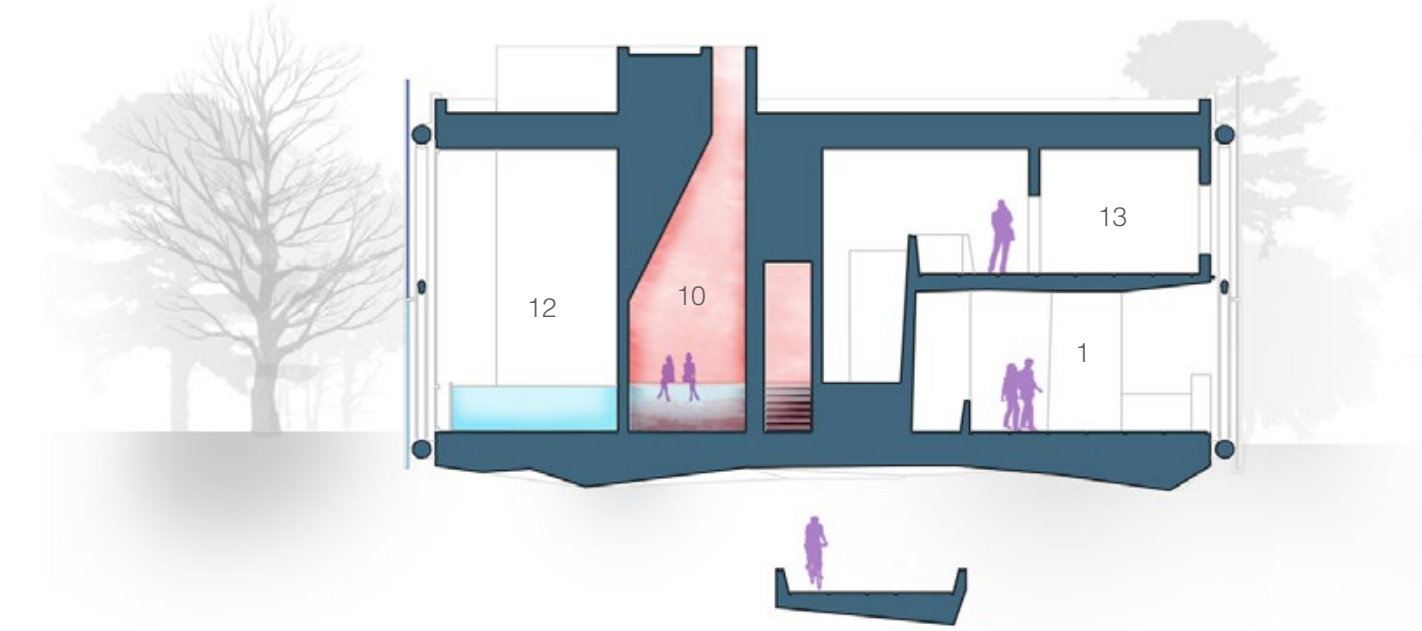

section b-b

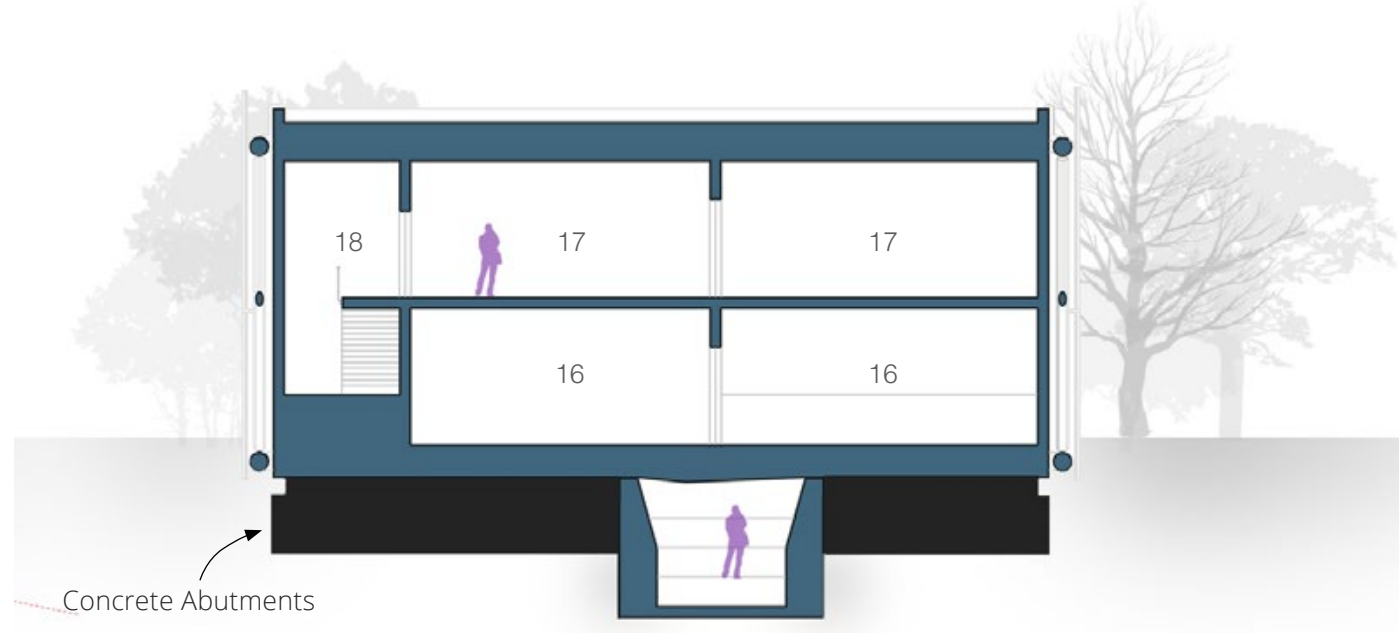

Concrete Abutments

section d-d

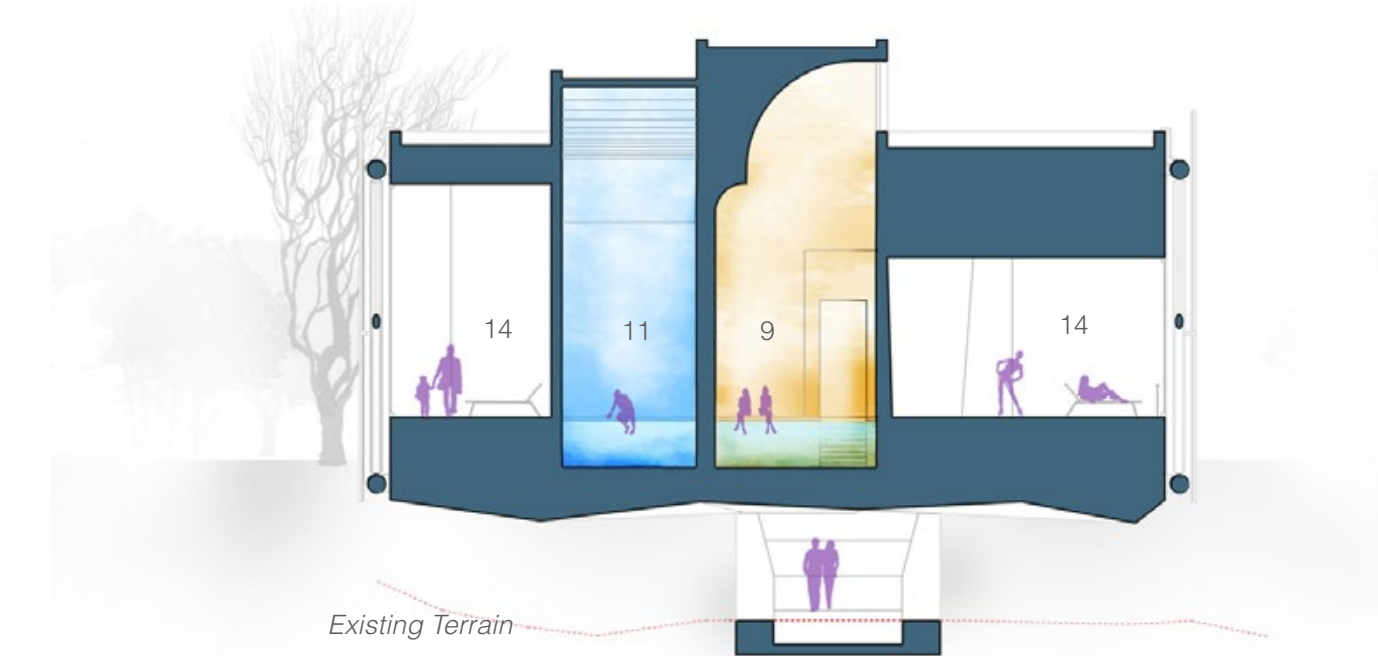
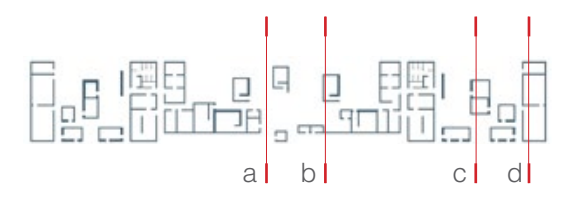
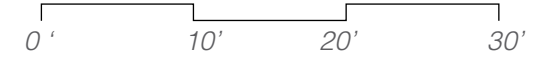

Existing Terrain

section c-c

- 1. Entrance / Lobby
- 6. Locker Room Female
- 6'. Locker Room Male
- 7. Showers
- 9. Warm Bath
- 10. Fire Bath
- 11. Cold Bath
- 12. Indoor Pool
- 13. Massage Room
- 14. Rest Spaces
- 15. Sauna
- 16. Mechanical Room
- 17. Mechanical Room
- 18. Exit Stairs

between interior and exterior

The entry point in the Bathhouse serves as a transition between the exterior and the interior. The use of triangulated shapes and the combination of the interior and exterior materials helps to express this relationship.

Main entrance



lobby

For the interior mainly is used Calcutta marble with different cuts for the floor and walls. The lobby has a difference floor level with the Mixed zone on the right. The lobby is visually connected to the mixed zone, in this way inviting the visitors to explore the other areas of the Bathhouse. The small transparent glass openings provide a connection but at the same time saving the privacy of the mixed zone. The transparent glass protects from the noise while providing a good visibility.

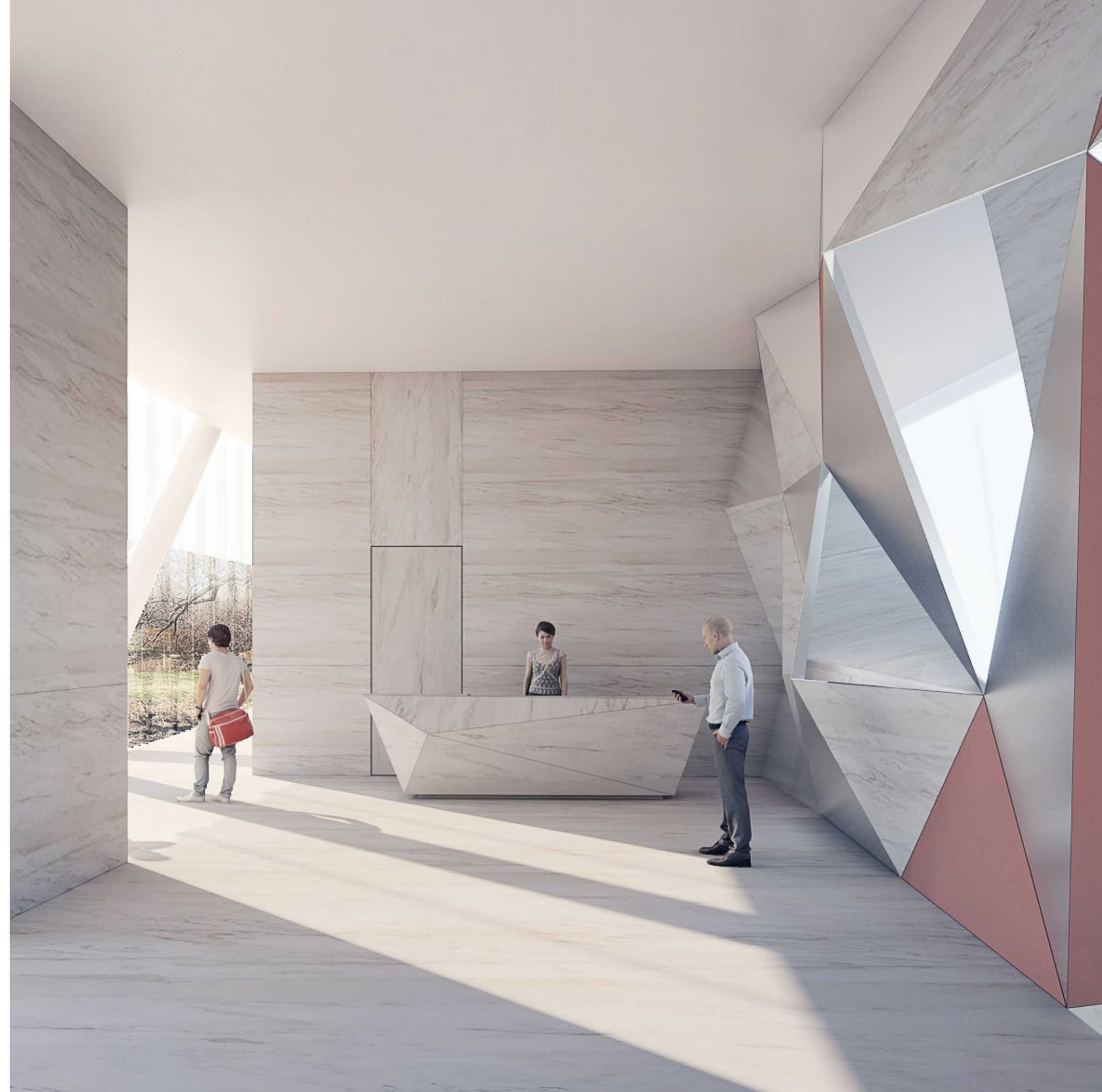

the corridor

After the reception, the users will pass through a long ramp to access the other spaces. The interior here consists of a combination of Marble, glass, and the exposed white steel elements. The visitors will have a full view to the outside landscape.



resting spaces

These spaces provide a full view to the city skyline. To better enhance the experience the only visible elements are the white structural steel. As structural elements are used pipe section steel. The marble is used for the floor and walls.

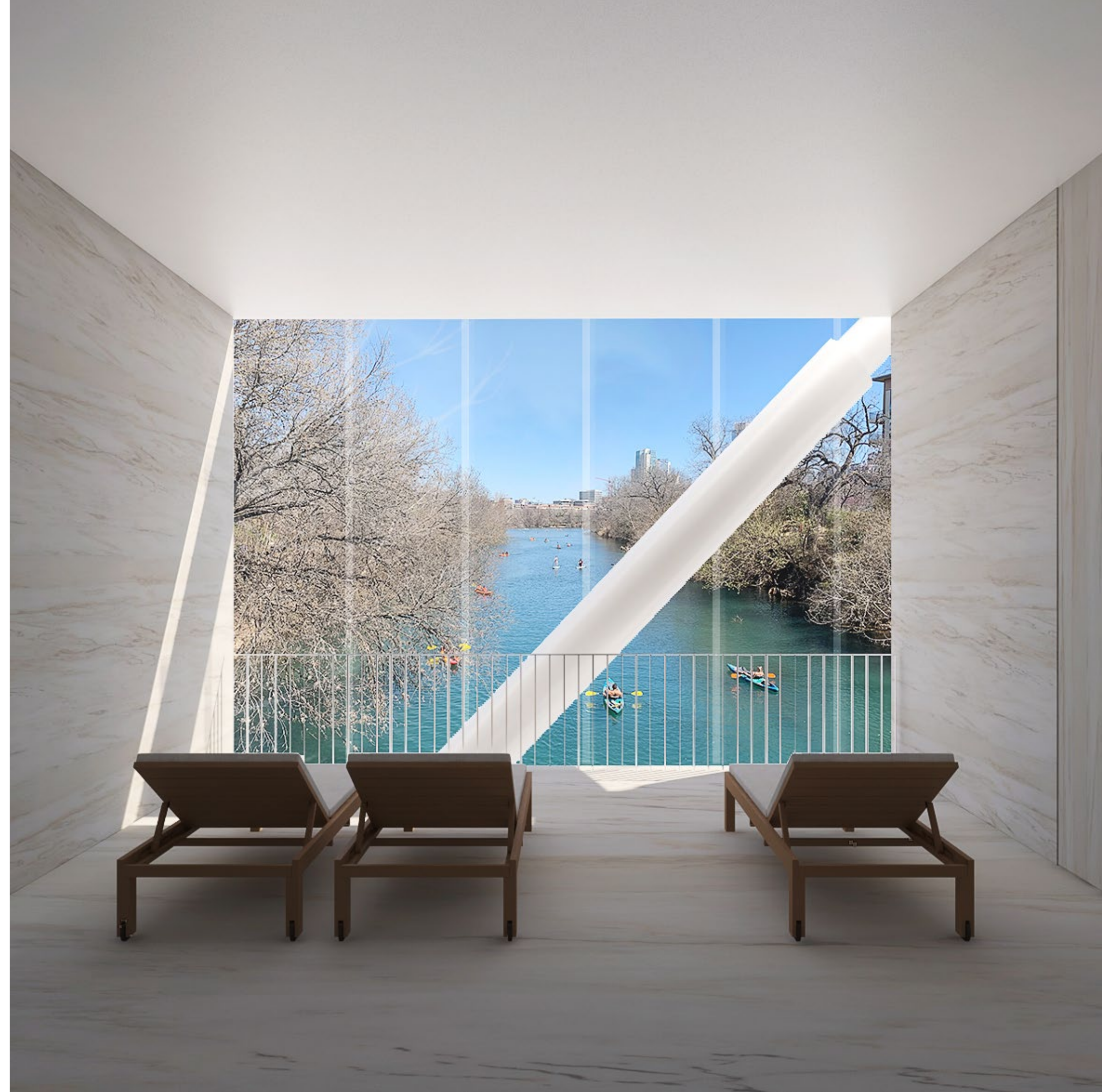



daylighting strategies

These diagrams represent the sun path during the June and December Solstice in Austin. The maximum sun angle reaches 68 degrees during the summer, whereas the maximum sun angle during the winter is 35 degree. These angles will inform the design of the main interior spaces; hot, cold and warm bath.

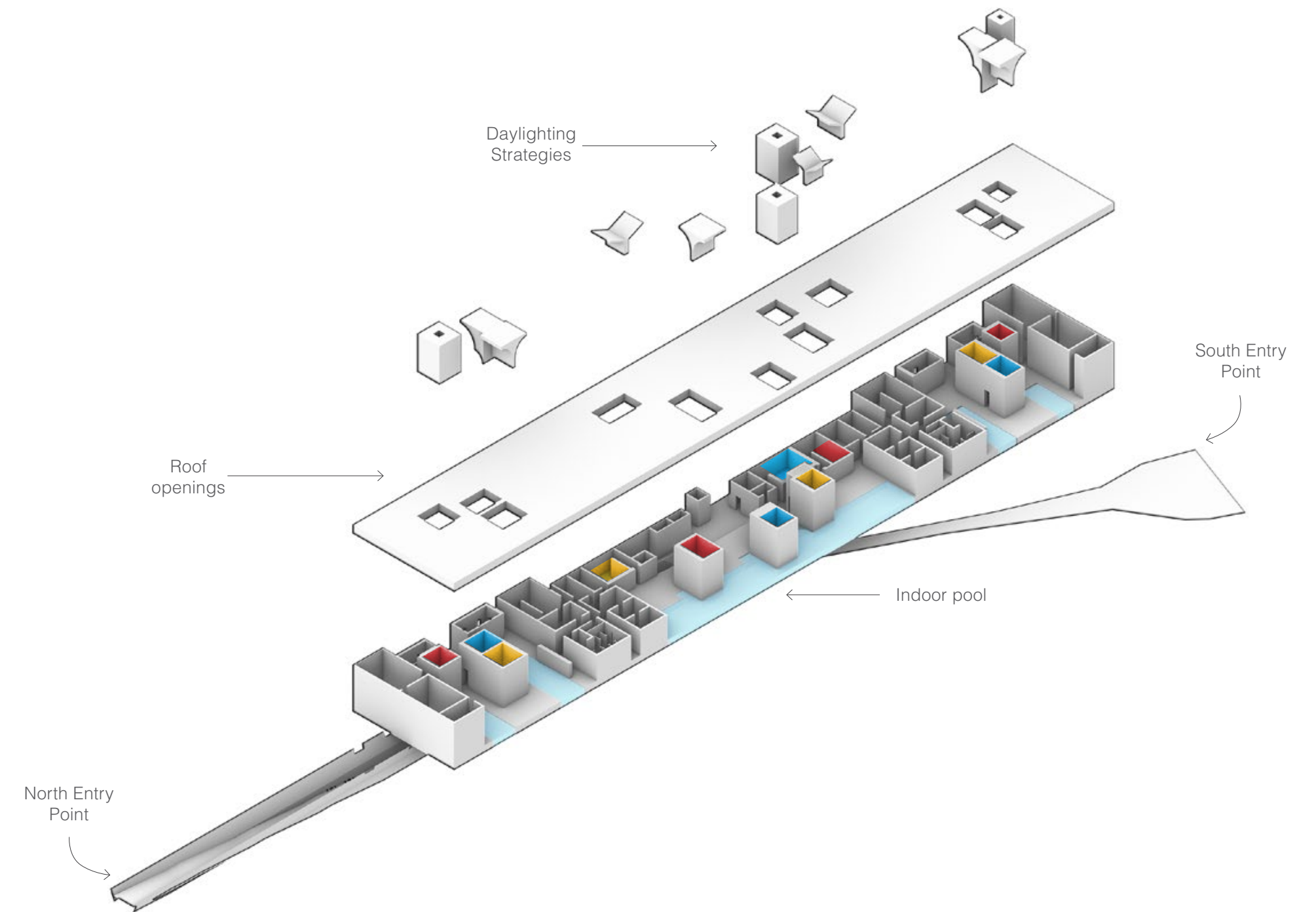
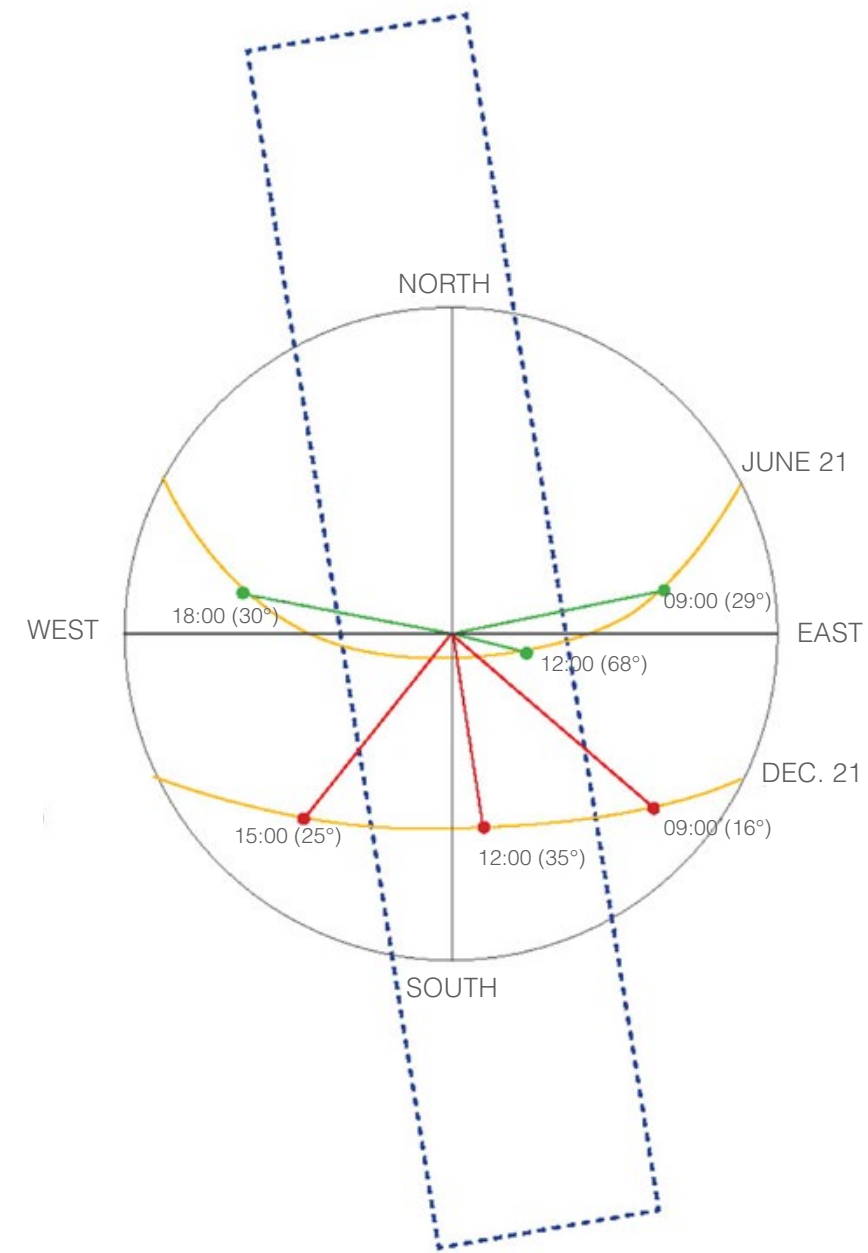
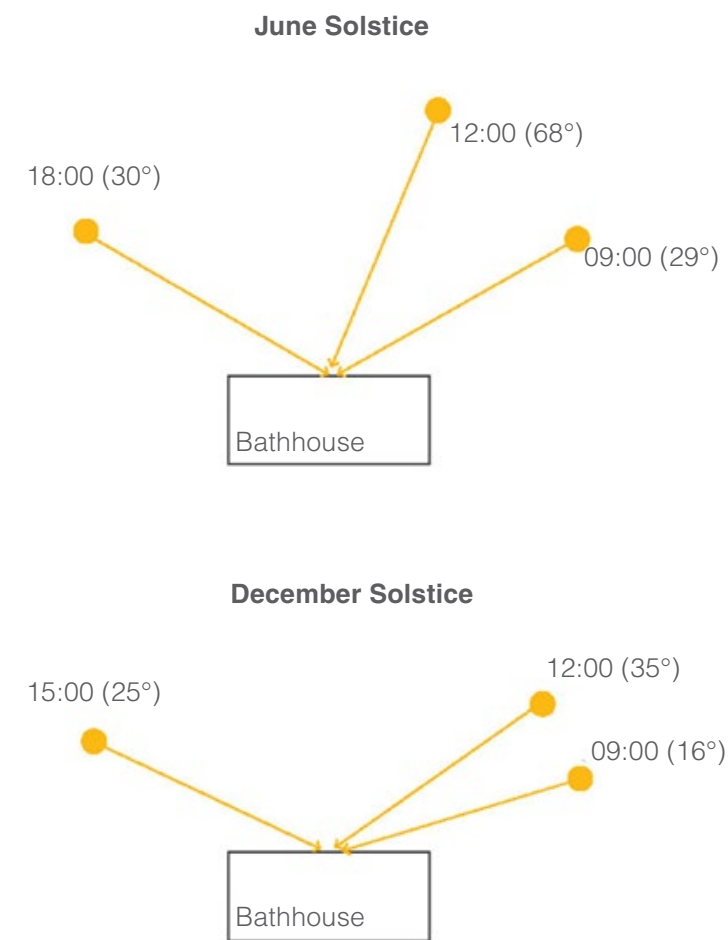

hot, cold and warm bath

These are important spaces in a Bathhouse, and as such, it is given special attention to the design. Each of these spaces have different temperature, the warm bath has a temperature of 97° Fahrenheit, the hot bath reaches a maximum of 108°F and the cold bath a minimum of 57°F. In each of these spaces are used thicker walls, to isolate the temperature, and to allow air circulation within the room.

To enhance the experience of the space, in each of these rooms is introduced natural and artificial lighting. Red, blue and orange accordingly to the Hot, Cold and Warm bath.

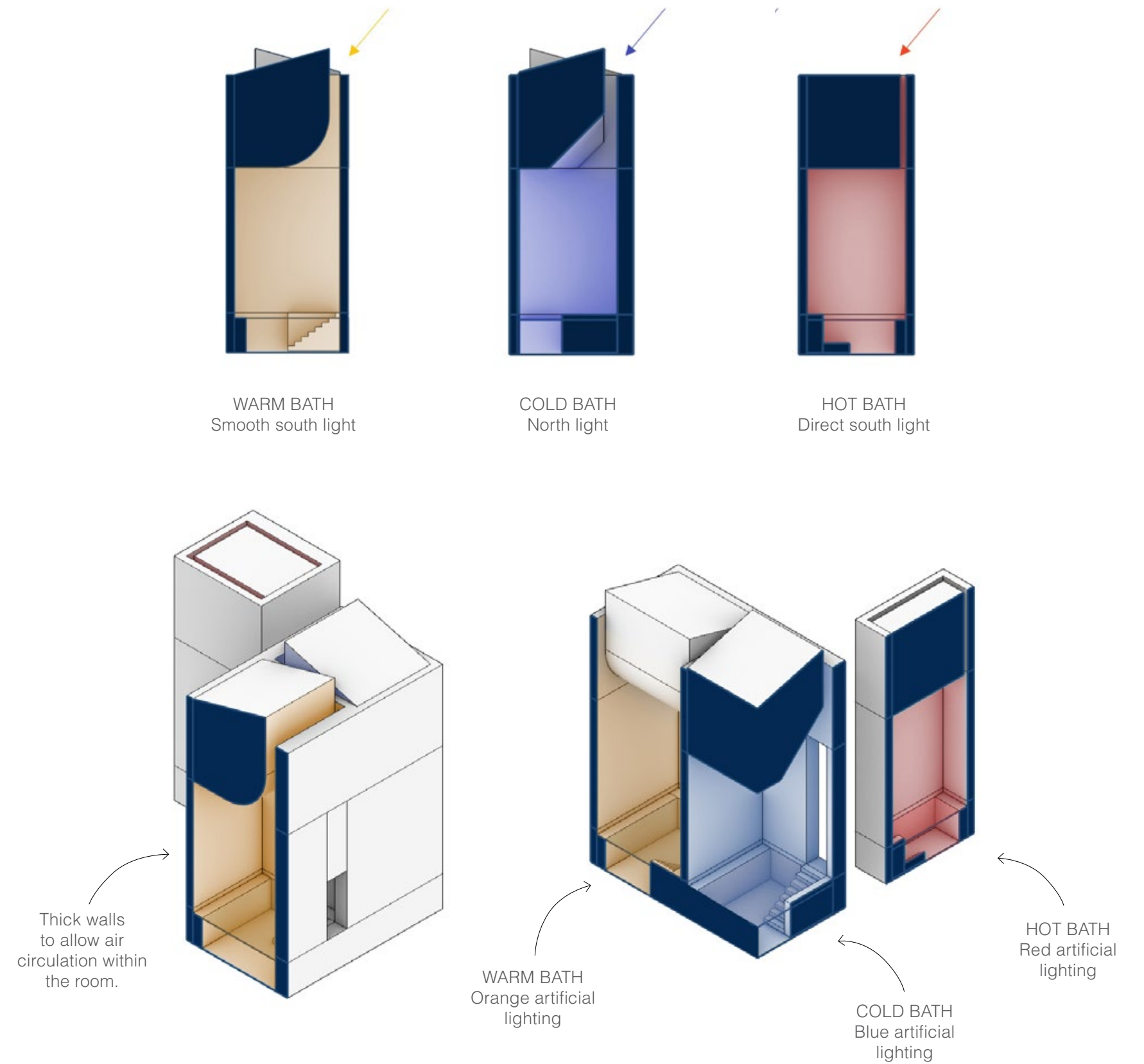
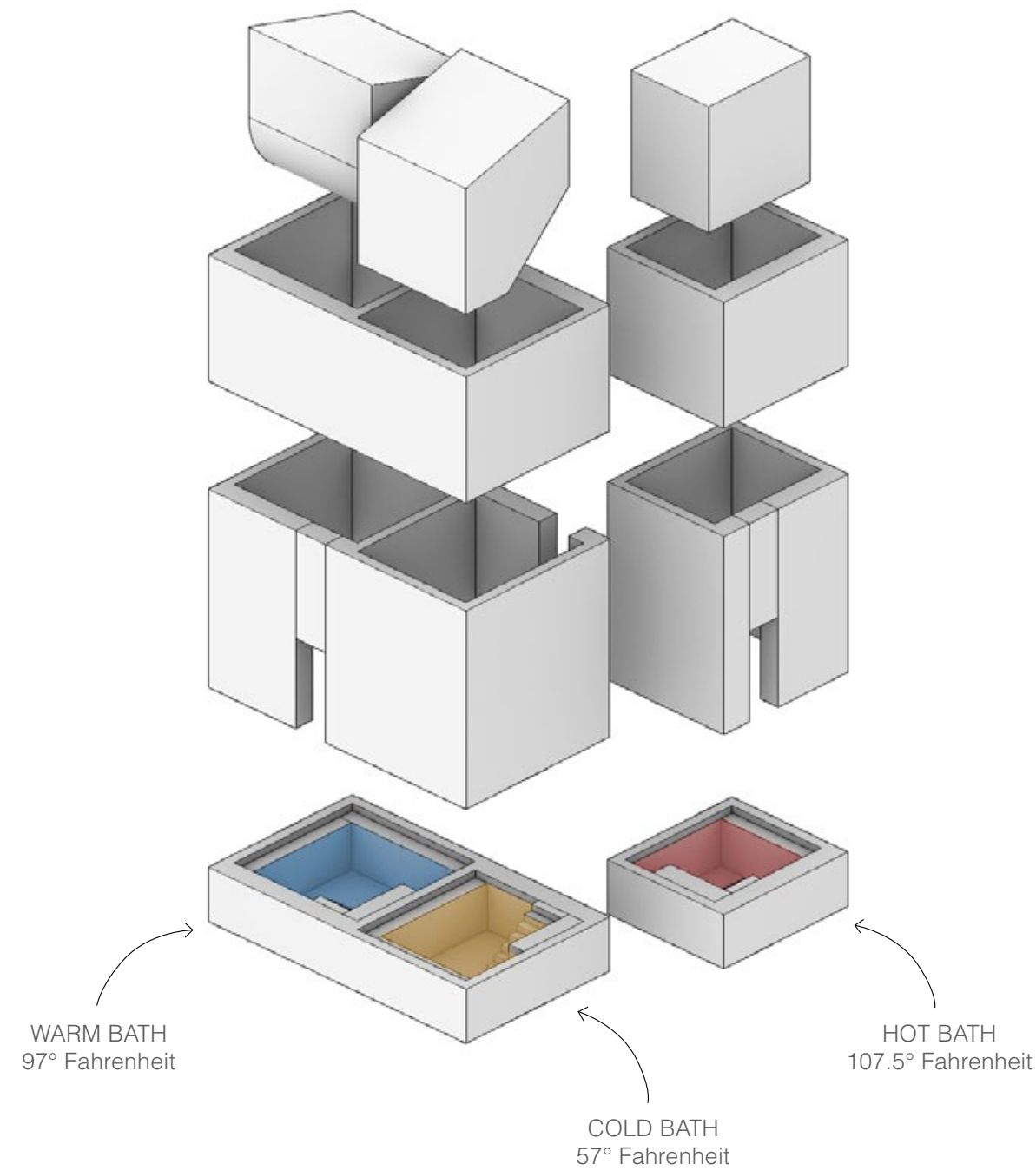

12 studies in light, space and water

Sectional light study model 21 June

This study is made for the main treatment rooms, hot, cold, and warm bath. Three factors were taken into consideration: the light, space, and water. The purpose was not to choose between different variations, but through observation to understand the atmospheres that could be created by the combination of these elements in different ways. While keeping water as a constant I played with space and light. Space was taken as dematerialized, to avoid the effect that could have at this stage of the design.

Three were the main categories where I arranged the variations. The direct, indirect, and dramatic light. Each one of these categories drives the atmosphere of the space. What adds more to the atmosphere is the articulation of the space.

Another important element that was taken into consideration was time. The time directly affects the quality of the light. The baths during the week will be used mostly after working hours, at 6 or 7 pm. While at weekends, which is also the peak, during midday. So, the variations also represent these different times of the day.

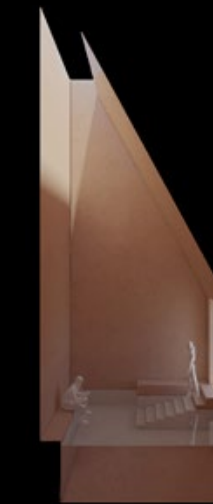

Direct Daylight



Tension



Excitement



Contemplative

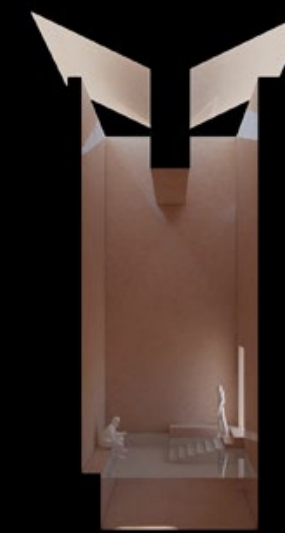

Indirect Daylight



Calm



Soft

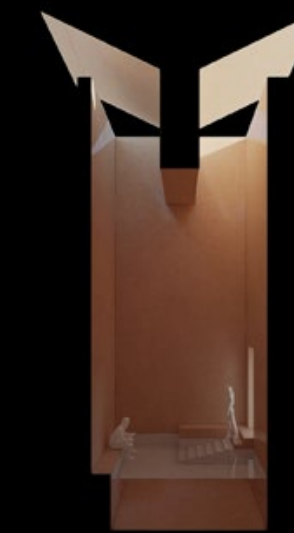

Relaxing



Dramatic Daylight



Spiritual



Dramatic



Energetic

hot, cold and warm bath

The use of marble in the interior, and the effect of the artificial lighting enhances more the experience of the space. The sitting areas are made of wood due to its lower thermal mass. Making it more comfortable to stay for a longer time.



hot bath



warm bath



cold bath

structure

Three types of steel are used, the Wide Flange, Pipe truss and HSS members. Pipe truss is mainly used where the structure is visible from the interior. Also, for the main steel truss are used diagonal bracing elements to help from lateral forces. The bridge is suspended from the main steel structure at the middle, where it changes the direction.

The span 250 foot
 Height 30 foot
 Width 49 foot

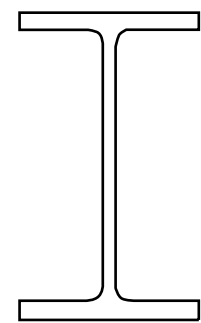

Wide Flange Members

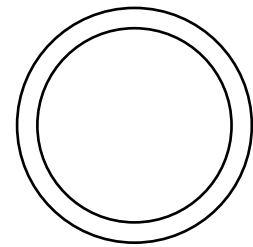

Pipe Truss Members

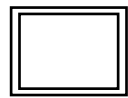

HSS members

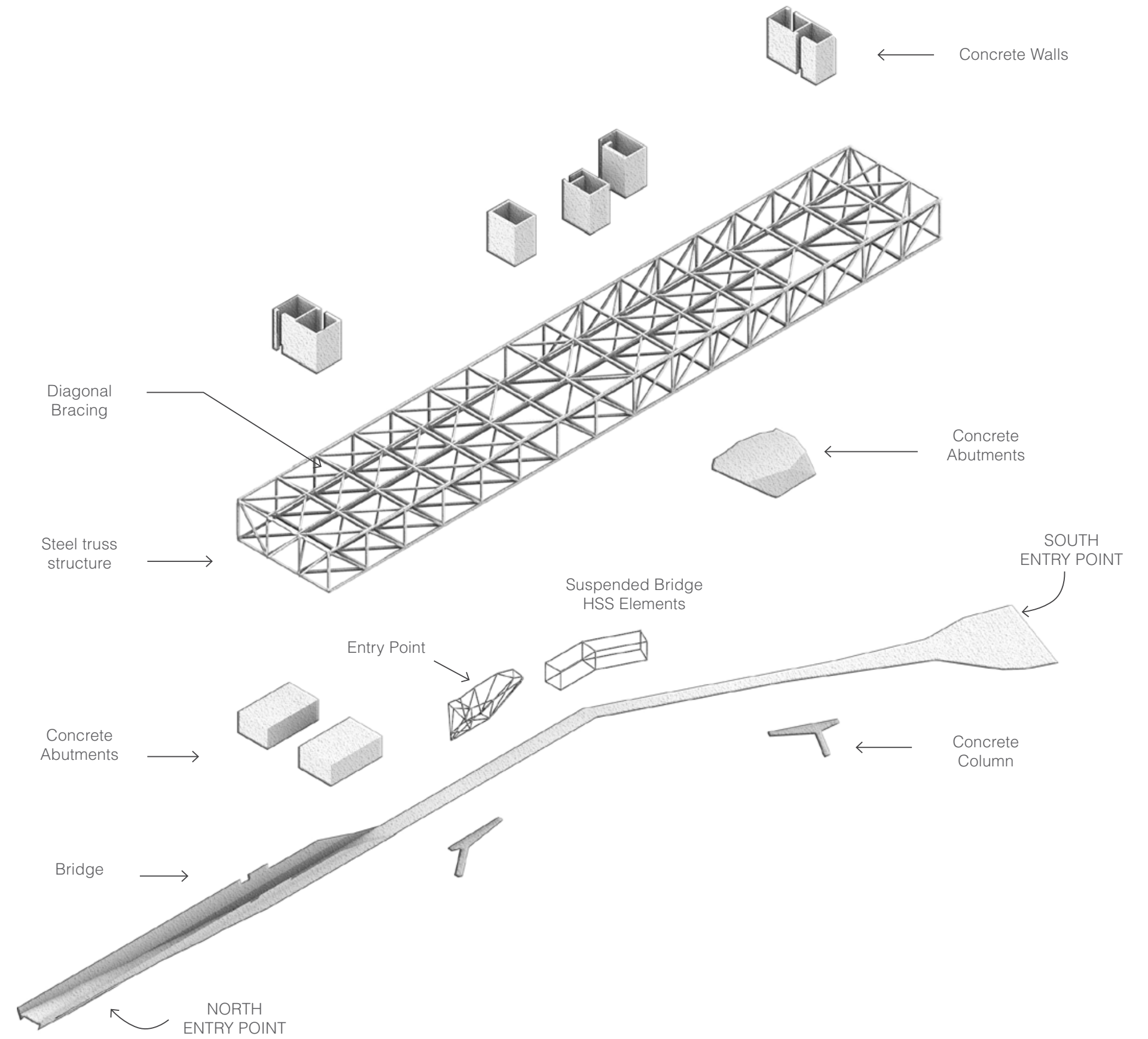

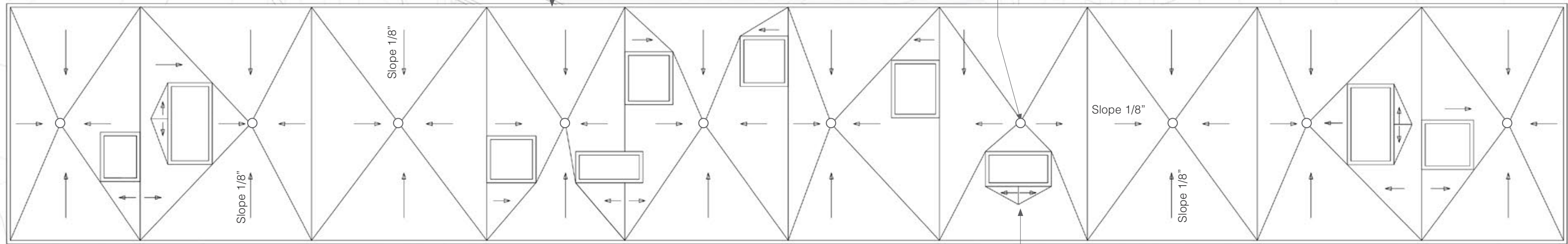

Roof Parapet

Roof Drain

Cricket

roof plan



○ Internal Drainage System
 ↗ Slope 1/8 "

wall section details

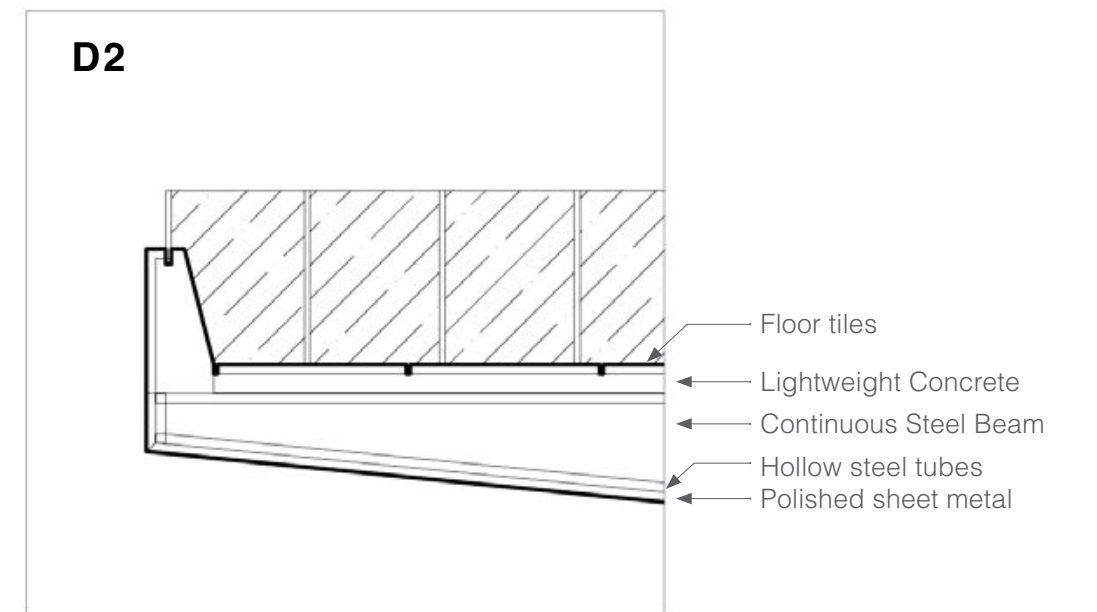
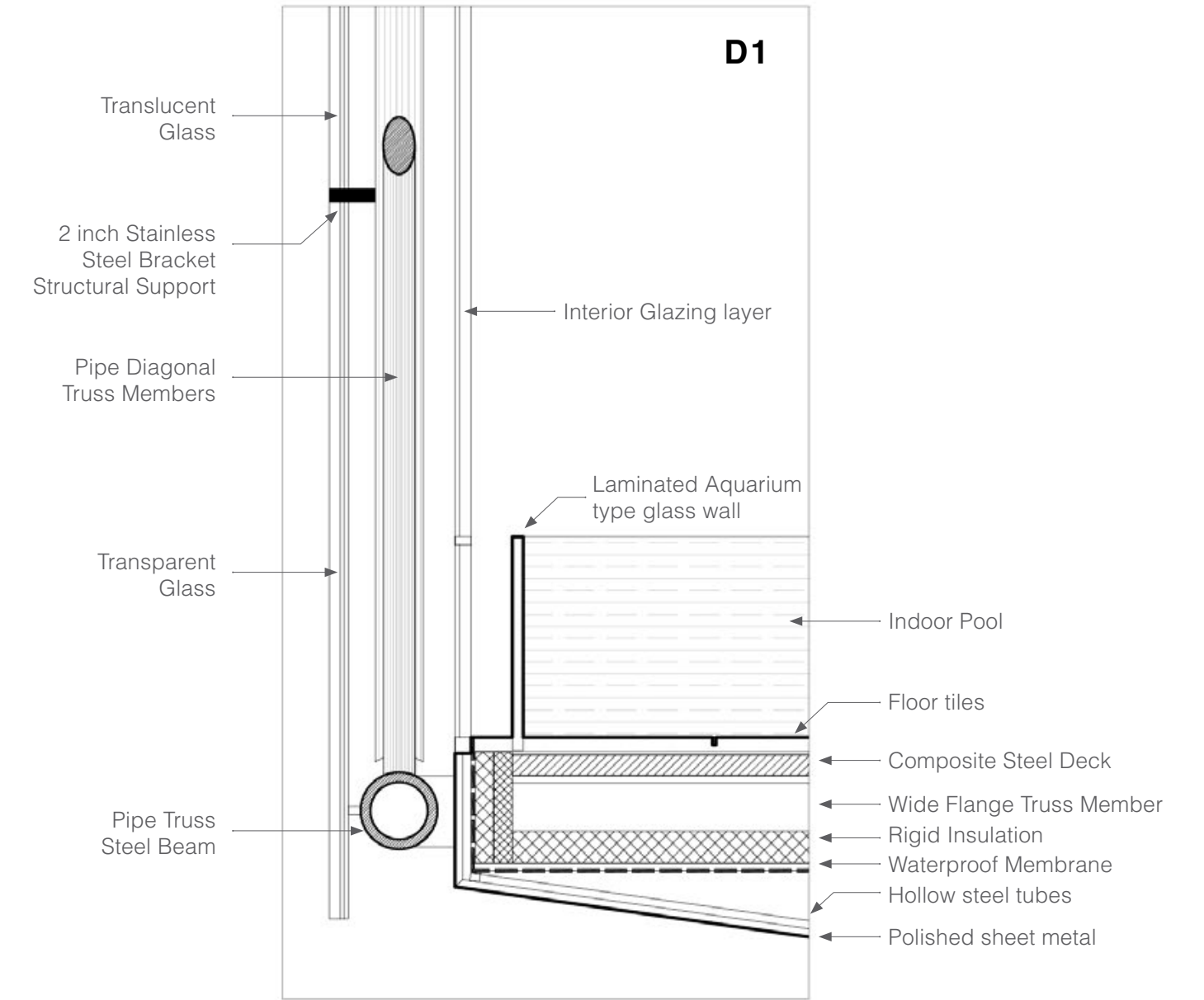
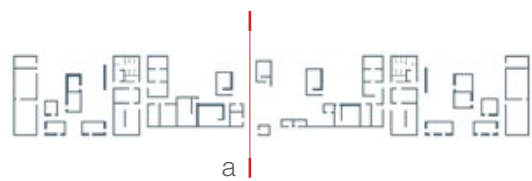
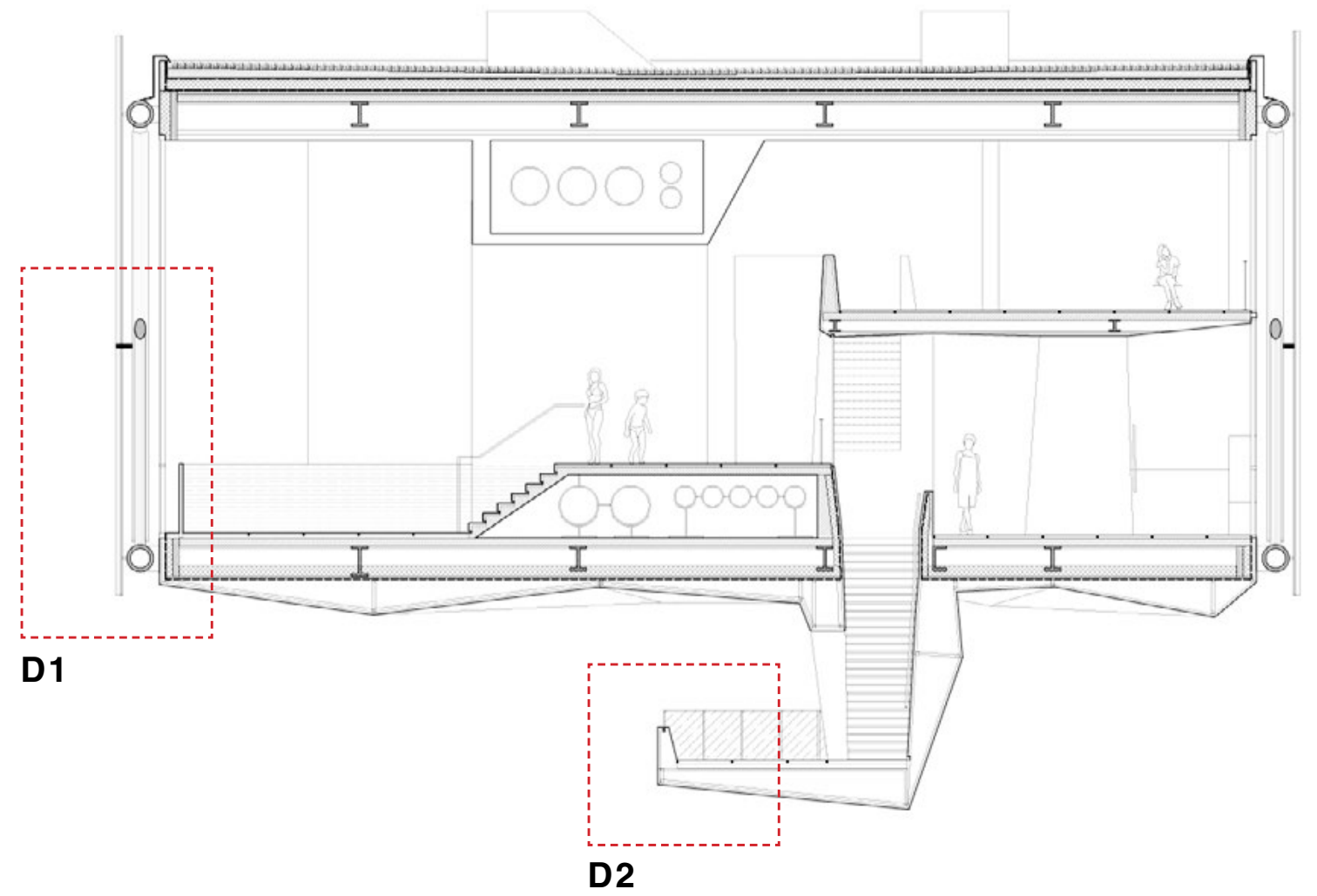

wall section details

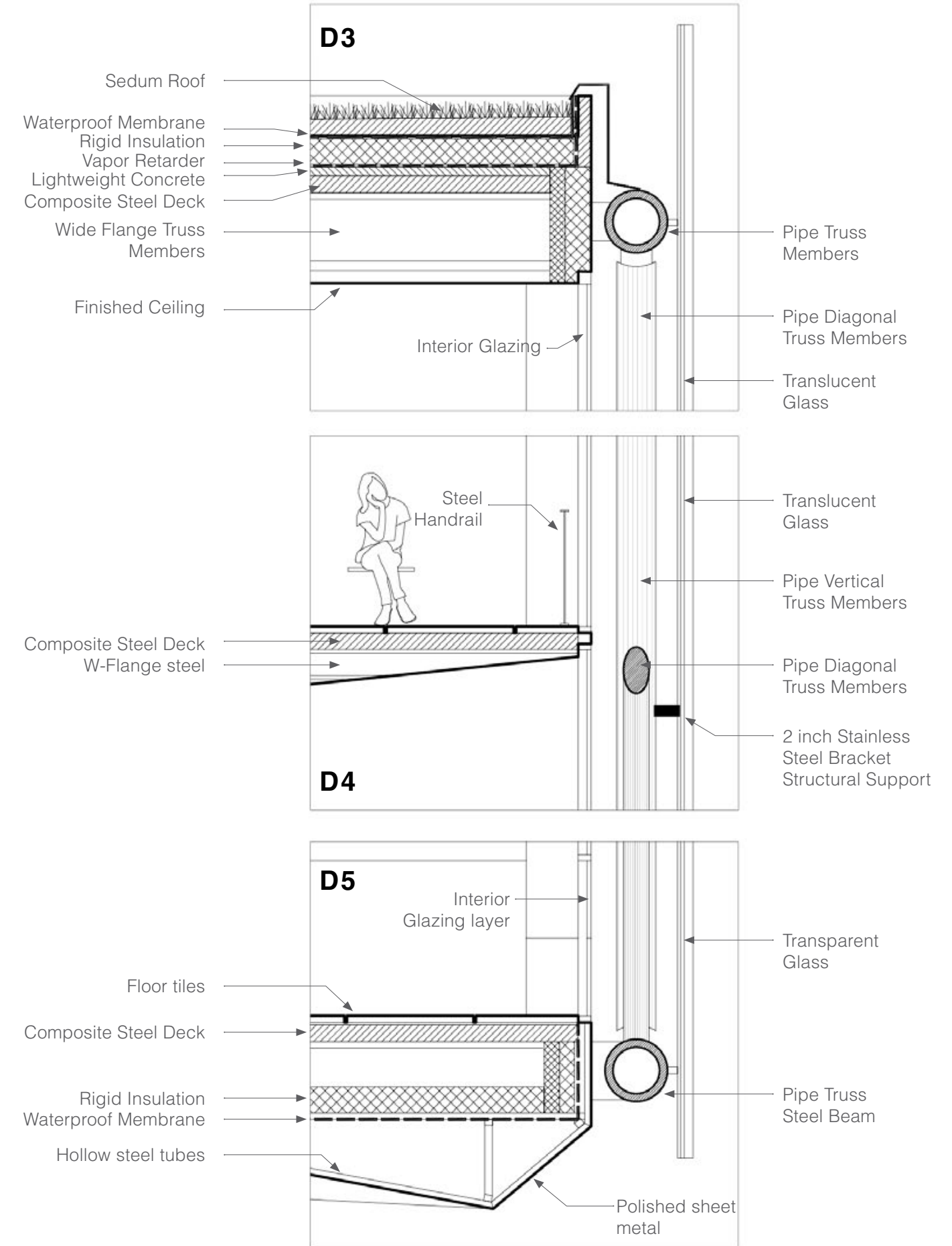
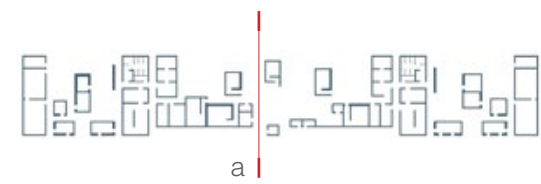
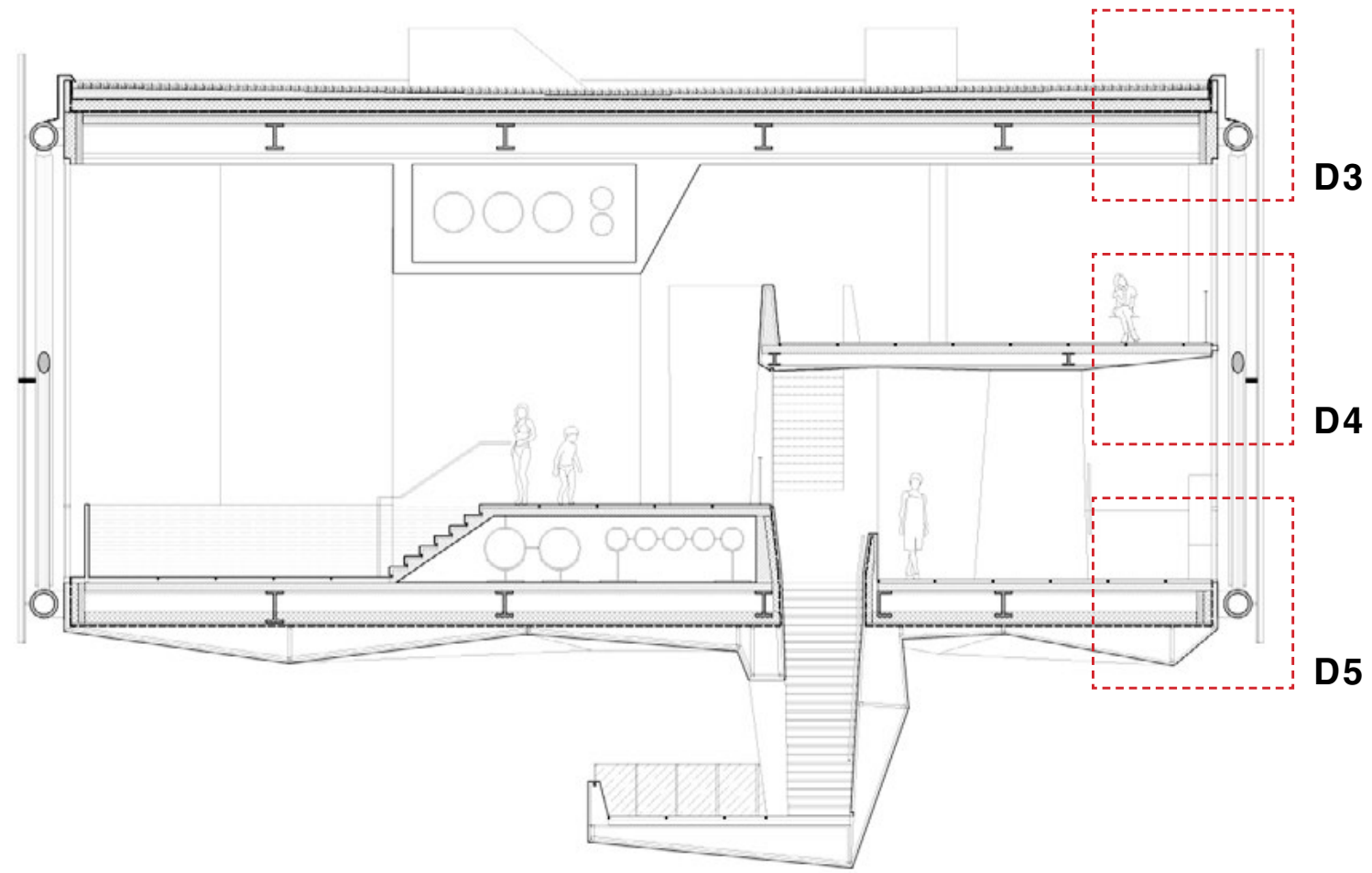



conclusion

Reintroducing the public bathhouse to the American Society focuses on the important historical role of this typology in addressing public health and wellbeing. Especially today, when focus has shifted closer to preventive medicine, maintaining one's well being has gained importance.

This project has been an exploration journey through architectural concepts. The design speaks about different feelings and atmospheres, through a combination of structural shapes, materials, lighting, and nature. The design aims to create a sensuous experience for the visitors while responding to the surrounding context and culture.

bibliography

1. Zumthor, P. (2006). Peter Zumthor: Atmospheres: Architectural environments, surrounding objects. Basel: Birkhäuser.
2. Zumthor, P. (2017). Thinking architecture. Basel: Birkhäuser.
3. ALLSOP, R. O. (2016). Turkish bath, its design and construction. HANSEBOOKS.
4. Yegül, F. K. (1992). Baths and bathing in classical antiquity. New York, NY: Architectural History Foundation.
5. Croutier, A. L. (1992). Taking the waters: spirit, art, sensuality: Abbeville Press.
6. Sigfried Giedion, Mechanization Takes Command: A Contribution to Anonymous History (Minneapolis, MN: University of Minnesota Press, 2013 [1948]), p. 628.
7. Tsonis, J. (2017). Sauna studies as an academic field: a new agenda for international research. Literature & Aesthetics, 26(1).
8. Snare, Audrey, "Just Add Water: Rethinking the Urban Bath House for Contemporary Society" (2012).
9. Architecture Senior Theses. 65. https://surface.syr.edu/architecture_theses/65
10. Katriina Kukkonen-Harjula & Kyllikki Kauppinen (2006) Health effects and risks of sauna bathing, International Journal of Circumpolar Health, 65:3, 195-205, DOI: 10.3402/ijch.v65i3.18102
11. Atkinson, J. Ablution, A new arena of social inclusion for northern Marseille, https://issuu.com/johnatkinson91/docs/cdp_report.compressed
12. About preventive medicine. (n.d.). Retrieved April 21, 2021, from <https://www.acpm.org/about-acpm/what-is-preventive-medicine/#:~:text=Preventive%20medicine%20is%20a%20medical,prevent%20disease%2C%20disability%20and%20death>.
13. Aaland M. (1997) History of the Finnish Sauna and the Nordic Bath <https://www.finnleo.com/hubfs/assets/health-benefits-library/sauna-history-trivia/cyberbohemia.com-History-of-the-Finnish-Sauna-and-the-Nordic-Bath.pdf>

images

Pg. 09:
Panofka, Th. Women taking a shower [jpg]. Medium. <https://medium.com/@ancientworldalive/ancient-greek-and-roman-bathing-94a585ad3c4f>
Murillo, L. View of the Baths of Diocletian complex in Rome today [jpg].Inexhibit. <https://www.inexhibit.com/myrmuseum/baths-diocletian-rome-archaeological-site-museum/>

Pg. 10:
Wikimedia Commons. Turkish Bath in Acre [jpeg]. Retrieved March 12 from https://commons.wikimedia.org/wiki/File:Turkish_Bath_in_Acre.JPG
[Photos courtesy of Benesse Art Site], <http://www.cartogramme.com/explore/japan-naoshima-bath/>

Pg. 11:
(Ephemeral New York n.d.) The Russian baths on posh “La Fayette Place” [jpg]. Retrieved March 10 from <https://ephemeralnewyork.files.wordpress.com/2011/09/russianbathslithograph-e1316664768684.jpg?w=584>
(Finish American Sauna, n.d.), Heritage, Retrieved March 10 from <http://www.saunaparts.com/heritage-1>

Pg. 12:
New-York Historical Society, Interior of Swimming Bath, Harper’s Weekly, (1870). Geographic File, PR 020. <https://www.nyhistory.org/node/62836>
[Treat Yourself with These 10 Spa Getaways] (2019), <https://www.iloveny.com/blog/post/spa-getaways/>

Pg. 13:
Archdaily. Peter Zumthor’s Therme Vals Through the Lens of Fernando Guerra. (2016), <https://www.archdaily.com/798360/peter-zumthors-therme-vals-through-the-lens-of-fernando-guerra/580faebee58ecef67000080-peter-zumthors-therme-vals-through-the-lens-of-fernando-guerra-photo>

Pg. 15:
(Wikiarquitectura n.d.) Thermas Vals, Retrieved March 15 from <https://en.wikiarquitectura.com/building/thermas-vals/>
Zumthor, P. (2008), Therme Vals, Pg 77

Pg. 16:
Archdaily. Peter Zumthor’s Therme Vals Through the Lens of Fernando Guerra. (2016), <https://www.archdaily.com/798360/peter-zumthors-therme-vals-through-the-lens-of-fernando-guerra/580faebee58ecef67000080-peter-zumthors-therme-vals-through-the-lens-of-fernando-guerra-photo>

vals-through-the-lens-of-fernando-guerra/580faebee58ecef67000080-peter-zumthors-therme-vals-through-the-lens-of-fernando-guerra-photo (Pinterest n.d.) Uploaded by os3um, Retrieved March 12 from <https://www.pinterest.com.mx/pin/511299363944983761/>
(Trip n.d.) 7132 Hotel, Retrieved March 12 from <https://www.trip.com/hotels/vals-hotel-detail-7691571/7132-hotel/>
(Architizer n.d.), Vals Thermal Spa, Retrieved March 15 from <https://architizer.com/projects/vals-thermal-spa/>

Pg. 20:
Google. (n.d.). [Google Maps map of Austin city center]. Retrieved March 10, 2021 from <https://earth.google.com/web/@30.26754728,-97.75823221,133.01110342a,3060.98507482d,35y,0h,0t,0r>

Pg. 21
Snazzymaps (n.d.). [Maps of Austin city]. Retrieved March 10, 2021 from <https://snazzymaps.com/>

Pg. 25-26:
Google. (n.d.). [Google Maps map of Austin city center]. Retrieved March 10, 2021, from <https://earth.google.com/web/@30.26754728,-97.75823221,133.01110342a,3060.98507482d,35y,0h,0t,0r>

Pg. 31-32:
McGilvray J., (2012), Vegetation map, Zilker Park Cultural Landscape Report. <https://repositories.lib.utexas.edu/handle/2152/31393>
McGilvray J., (2012), Buildings and Structures, Zilker Park Cultural Landscape Report. <https://repositories.lib.utexas.edu/handle/2152/31393>
McGilvray J., (2012), Landscape characteristic map, Zilker Park Cultural Landscape Report. <https://repositories.lib.utexas.edu/handle/2152/31393>
McGilvray J., (2012), Archeological Sensitivity Map, Zilker Park Cultural Landscape Report. <https://repositories.lib.utexas.edu/handle/2152/31393>

Pg. 33:
LIMBACHER & GODFREY Architects (December, 2008) BARTON SPRINGS POOL Master Plan, Concepts for Preservation and Improvement, pg. 110

Pg. 37:
Dezeen. The Twist Museum / BIG (2019). <https://www.dezeen.com/2019/09/19/big-the-twist-art-gallery-kistefos-sculpture-park/#/>
Dezeen. The Twist Museum / BIG (2019). <https://www.dezeen.com/2019/09/19/big-the-twist-art-gallery-kistefos-sculpture-park/#/>

Pg. 38:
“The Twist Museum / BIG” 18 Sep 2019. ArchDaily. Accessed 18 Apr 2021. <<https://www.archdaily.com/925106/the-twist-museum-big>> ISSN 0719-8884
Ramboll. Kistefos Museum (2019). <https://ramboll.com/digital-solutions/buildings/kistefos-museum>

Pg. 45:
(Etsy n.d.) Barton Springs -Austin, Texas (2016), Retrieved March 12, 2021 from https://www.etsy.com/listing/644998843/barton-springs-austin-texas-ready-to?ga_order=most_relevant&ga_search_type=all&ga_view_type=gallery&ga_search_query=barton+springs&ref=sr_gallery-1-25&organic_search_click=1&frs=1

Pg. 48:
Buildipedia, (2012), Milstein Hall: How Old Meets New, <http://buildipedia.com/aec-pros/featured-architecture/milstein-hall-how-old-meets-new>
Dezeen, (2020), Glass tubes and curvy roofs play with light in Steven Holl’s Houston arts museum, <https://www.dezeen.com/2020/11/17/nancy-and-rich-kinder-building-museum-of-fine-arts-houston-steven-holl/meets-new>

Pg 63:
[Close-up of Columns at the Austrian Parliament Building, Vienna, Austria] <https://www.masterfile.com/image/en/700-02990022>

vitae

u r a n s o k o l i

education

Master of Architecture
Texas A&M University
2021

Professional Master in Parametric Design
Polis University, IHS/Erasmus University Rotterdam
2019

Master of Science in Architecture
Polytechnic University of Tirana
2016

experience

Graduate Assistant
Texas A&M University.
2019-2021

Architect
SON Engineering & Construction
2016-2019

Interior Designer
Asymmetric Studio
2016

Intern Architect
Ministry of Healthcare
2015

