

Oxidation of Ethylene Glycol by a Salt-Requiring Bacterium

WILLIAM H. CASKEY†* AND WILLARD A. TABER

Department of Biology, Texas A&M University, College Station, Texas 77843

Received 9 March 1981/Accepted 1 May 1981

Bacterium T-52, cultured on ethylene glycol, readily oxidized glycolate and glyoxylate and exhibited elevated activities of ethylene glycol dehydrogenase and glycolate oxidase. Labeled glyoxylate was identified in reaction mixtures containing [¹⁴C]-ethylene glycol, but no glycolate was detected. The most likely pathway of ethylene glycol catabolism by bacterium T-52 is sequential oxidation to glycolate and glyoxylate.

Although there are a number of reports of pure cultures of bacteria which can metabolize ethylene glycol (1, 3, 5, 6), the metabolic route has been studied for few bacteria. *Acetobacter* and *Gluconobacter* species oxidize ethylene glycol and accumulate only glycolic acid (2). Glycolate is commonly oxidized to glyoxylic acid (4, 17). Jones and Watson (8) reported that an *Acinetobacter* strain utilized ethylene glycol via the glycolaldehyde, glyoxylate, and glycerate pathways to produce pyruvate (12). Gonzalez et al. (6) described a halophile, bacterium T-52 (ATCC 27042), that readily oxidized glycolate when grown on either ethylene glycol or glycolate and also detected glycolate oxidase activity in cell-free extracts of the bacterium. We now present evidence that, like certain other isolates, bacterium T-52 oxidizes ethylene glycol sequentially to glycolate and glyoxylate (Fig. 1).

Knowledge of the catabolism of ethylene glycol is essential for development of an efficient biological treatment process for water containing ethylene glycol. Because of their widespread production and utilization, glycols as a group constitute a considerable organic load in waste treatment systems. Bacterium T-52 offers the advantage over other ethylene glycol-degrading bacteria of tolerance to the high NaCl concentrations frequently found in wastewater resulting from synthesis of polyhydric compounds.

Bacterium T-52 was cultured in shaken cultures incubated at 30°C in a mineral salts broth containing 3.4% (wt/vol) NaCl (6) supplemented with ethylene glycol, sodium glycolate, glyoxylic acid, or glycerol (4.2 g of C per liter). The increase in turbidity at 640 nm during growth was measured spectrophotometrically and converted to the cell dry weight equivalent by using an experimentally determined conversion factor.

Rates of oxidation of ethylene glycol, glycolic

acid, and glyoxylic acid by resting cell suspensions incubated at 30.6°C were determined by using a Warburg respirometer.

Cells cultured on ethylene glycol or glycerol were harvested after 36 h of incubation by centrifugation at 5,900 × g for 10 min at 5°C, washed twice in phosphate buffer (0.1 M, pH 7.2), and suspended in the same buffer to a concentration of 12 to 15 mg ml⁻¹. Cells were broken by sonicating 50 ml of the cell suspensions in a 10-kc Raytheon sonic oscillator for 20 min and centrifuging at 20,200 × g for 30 min at 5°C. Protein was assayed by the method of Lowry et al. (11), using bovine serum albumin as the standard. Dehydrogenase activity (with ethylene glycol as the substrate) of this crude extract was determined by using optically adapted Thunberg tubes and a modification of the procedure of Payne and Todd (13). Glycolate oxidase (EC 1.1.3.1) activity of partially purified enzyme preparations was assayed by the procedure of Furuya and Hayashi (4). The precipitate that formed after the addition of solid (NH₄)₂SO₄ to 30% saturation was collected by centrifugation, and the pellet was dissolved in phosphate buffer (0.1 M, pH 7.2) and dialyzed against the same buffer for 6 h at 4°C.

A reaction mixture containing 200 mg of protein (crude extract) in phosphate buffer (0.1 M, pH 7.2) and 200 μmol of ethylene glycol with 5 μCi of [1,2-¹⁴C]ethylene glycol (ICN, Irvine, Calif.) was incubated at 30°C as described for cultures. Samples were periodically tested for the presence of glyoxylate by the colorimetric procedure of Wolf (16). When the concentration of glyoxylate reached 5 to 10 μg ml⁻¹, the reaction was stopped by quick freezing in liquid N₂ (for analysis of free organic acids) or by addition of 4 g of (NaPO₃)₃·6H₂O and 20 ml of a 1% (wt/vol) solution of 2,4-dinitrophenylhydrazine in 5 N H₂SO₄ (for analysis of 2,4-dinitrophenylhydrazone derivatives).

The free organic acids were extracted from

† Present address: USDA-SEA-AR, North Central Soil Conservation Research Laboratory, Morris, MN 56267.

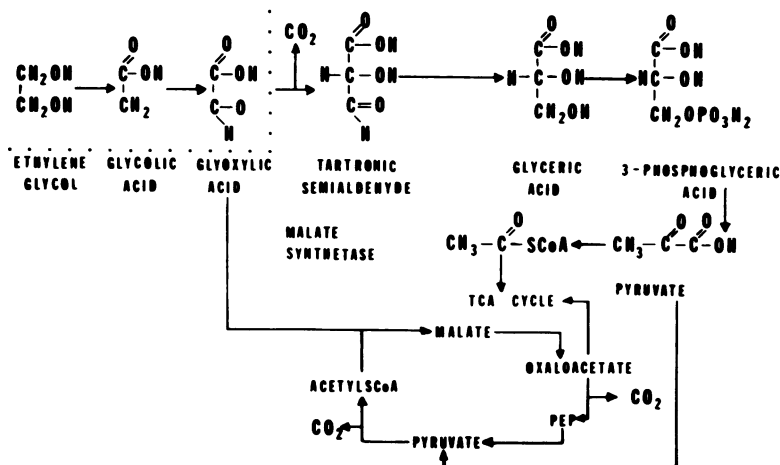

FIG. 1. Proposed pathway of metabolism of ethylene glycol by bacterium T-52. The reactions emphasized by the dotted lines are discussed in the text and the other reactions are included for completeness.

the freeze-dried concentrates of the frozen reaction mixture into absolute ethanol and mixed with Dowex 1 (bicarbonate form). The acids adsorbed on the resin were eluted with 1 N HCl, freeze-dried, dissolved in absolute ethanol, and analyzed by paper chromatography, using three solvent systems: (i) phenol-formic acid-water (75:25:1, vol/vol); (ii) butanol-formic acid-water (4:1:5, vol/vol) as described by Zweig and Sherma (18); and (iii) *n*-propanol-NH₄OH-water (6:3:1, vol/vol) as described by Hulme (7). The acid spots were revealed by dipping in xylose-aniline-methanol (1:1:100, wt/wt/vol) (7). Amino acids were detected by spraying the chromatogram with ninhydrin. Radioactivity was located with a Packard model 7201 radiochromatogram scanner.

The 2,4-dinitrophenylhydrazone derivatives were extracted from the treated reaction mixture with four successive portions (0.4 volume) of diethyl ether. Saturated NaHCO₃ was added until the mixture became alkaline (pH 8.4). The aqueous phase was collected, and the last traces of phenylhydrazone derivatives were removed from the ether by shaking with saturated NaHCO₃. The combined aqueous phases were acidified to pH 2.0 with 2 N H₂SO₄ and extracted three times with chloroform-ether (85:15, vol/vol). These extracts were combined and evaporated to dryness in vacuo at room temperature. The residue was dissolved in absolute ethanol and analyzed by using paper chromatography. The chromatograms were developed with the nonaqueous phase of a mixture of *tert*-amyl alcohol-ethanol-water (50:10:40, vol/vol) as the solvent, and the appropriate spots were viewed under ultraviolet light. The revealed derivatives were eluted with 0.2 M NaHCO₃, extracted with

chloroform-ether as above, and evaporated to dryness. The residue was dissolved in 3 ml of 0.2 M NaHCO₃, and the absorbance spectrum was determined by using a Bausch and Lomb Spectronic 505 spectrophotometer.

Ethylene glycol, glycolate, or glyoxylate served as the sole carbon source for growth of bacterium T-52. The use of inocula from cultures grown on ethylene glycol resulted in no difference in the rate of growth at the expense of any of these compounds during the first 12 h of incubation, and no lag period was discerned.

Resting cells of bacterium T-52 grown on ethylene glycol readily oxidized ethylene glycol, glycolate, and glyoxylate (Table 1). The ability to catabolize ethylene glycol was diminished when the cells were grown on either glycolic acid or glyoxylic acid, but the ability to respire both glycolate and glyoxylate was retained. Glycerol-grown cells oxidized all three compounds at very low rates. Glycerol neither stimulated nor suppressed the oxidation of ethylene glycol by bacterium T-52. Similar studies in which ¹⁴C₂O₂ evolution was measured during catabolism of [¹⁴C]ethylene glycol confirmed the low rate of oxidation when cells were grown on glycolate, glyoxylate, or glycerol. These data suggest that the enzymes for the metabolism of ethylene glycol, glycolate, and glyoxylate were induced during growth with ethylene glycol as the sole carbon and energy source, and that glycolate and glyoxylate are primary metabolites of ethylene glycol.

The average specific activity of ethylene glycol dehydrogenase was 0.2 U mg⁻¹ of protein for ethylene glycol-grown cells (Table 2). The slowness of this reaction *in vitro* has been reported previously (13) and probably reflects a sluggish

transfer of electrons to the artificial acceptor. Glycolate oxidase activity was higher in cells grown on ethylene glycol than in cells grown on glycerol (Table 2).

Although the colorimetric procedure of Wolf (16) indicated that glyoxylate was present, neither glycolate nor glyoxylate was detected in the free-acid analysis of the reaction mixtures, but radioactive spots were detected which corresponded with glycine and serine. Glycine has been shown to occur as a secondary metabolite from metabolism of compounds in which glyoxylate was an intermediate (15), and the amination of glyoxylate to glycine followed by condensation to serine has been reported (14). The absence of glycolate in the reaction mixture probably was the result of the more rapid rate of oxidation of glycolate. Extrapolating from the activity observed in the cell-free extracts, 0.65 μg of glycolate could be oxidized per h per mg of protein, whereas only 0.31 μg of ethylene glycol could be oxidized per mg of protein per h.

The presence of glyoxylate in the cell-free extracts incubated with [^{14}C]ethylene glycol was indicated by the characteristic formation of a red-to-orange color after the addition of phenylhydrazine, HCl, and $\text{K}_3\text{Fe}(\text{CN})_6$ (16). Chromatography of the extracted 2,4-dinitrophenylhydrazine derivatives of compounds in the cell-free preparations yielded three radioactive spots. Two spots corresponded to the *cis* and *trans* isomers of authentic glyoxylate-2,4-dinitrophenylhydrazone. These were eluted, and the absorption maximum occurred at 365 nm, the reported wavelength of maximum absorption for the glyoxylate derivative (7). Spot 3 was not determined, but the bis-2,4-dinitrophenylhydrazone of tartronic semialdehyde, the bis deriva-

TABLE 1. Oxygen uptake during catabolism of ethylene glycol, glycolate, and glyoxylate by resting cells of bacterium T-52 cultured with different carbon sources

Carbon source for growth	Oxygen consumption ^a ($\mu\text{l mg}^{-1} \text{h}^{-1}$) with added:		
	Ethylene glycol	Glycolate	Glyoxylate
Ethylene glycol	10.7	16.4	14.8
Glycolate	1.1	38.4	36.8
Glyoxylate	1.6	29.3	30.1
Glycerol	1.0	5.5	3.5

^a Above endogenous uptake. Cells were suspended in 0.067 M phosphate buffer, pH 6.1, and 20 μmol of C was added from side arms. The basal solution for all reagents was 3.4% NaCl; total liquid volume was 3.2 ml. Endogenous uptake was monitored for 30 min before substrate was added.

TABLE 2. Dehydrogenase activity (with ethylene glycol as the substrate) and glycolate oxidase activity in cell-free preparations of bacterium T-52 derived from cells grown on ethylene glycol and glycerol

Carbon source for growth	Activity (U)		Sp act (U/mg of protein)	
	Dehydrogenase ^a	Glycolate oxidase ^b	Dehydrogenase	Glycolate oxidase
Ethylene glycol	5.0	3.5	0.2	5.5
Glycerol	0	0.8	0	0.9

^a The reaction mixture contained 0.06 mmol of $\text{K}_3\text{Fe}(\text{CN})_6$, 0.10 mmol of ethylene glycol in 8.5 ml of phosphate buffer (0.1 M, pH 7.2), and 3.0 ml of crude extract. The reaction was initiated by addition of ethylene glycol. One unit of activity was defined as the amount of enzyme causing a decrease in absorbance at 455 nm of 0.01 h^{-1} , equivalent to the oxidation of 0.10 μmol of ethylene glycol.

^b Volumes (2.15 ml) of phosphate buffer (0.1 M, pH 7.2), 0.1 ml of 0.1 M KCN in 0.01 M NH_4OH , 0.35 ml of 0.01% 2,6-dichlorophenol indophenol, and 0.2 ml of partially purified enzyme preparation were added to a cuvette, and the reaction was started by addition of 0.2 ml of 0.1 M sodium glycolate. One unit of activity was defined as the amount of enzyme causing a decrease in absorbance at 620 nm of 0.01 in min 1.

tive of glyoxal, or the 2,4-dinitrophenylhydrazone of hydroxypyruvate are possibilities (9, 10; G. Krakow, J. A. Hayashi, and S. S. Barkulis, Fed. Proc. 16:256, 1959). The orange color of the crystals and the rapid chromatographic migration with streaking indicated a bis derivative (18), but without authentic reference compounds, no further evidence of its identity was obtained. The bis derivative of glyoxal has no physiological significance, but the presence of tartronic semialdehyde would suggest that glyoxylate was metabolized via the glycerate pathway (Fig. 1) (12; Krakow et al., Fed. Proc. 16:256, 1959).

Further study is needed to optimize conditions for assaying the reactions occurring in the cell-free system, which could provide confirmation of glycolate as a metabolite. Isolation and characterization of the enzyme catalyzing the oxidation of ethylene glycol could provide information useful in exploiting bacterium T-52 in biological treatment of ethylene glycol-containing wastewaters.

LITERATURE CITED

1. Claus, D., and W. Hempel. 1970. Specific substrates for isolation and differentiation of *Azotobacter vinelandii*. Arch. Mikrobiol. 73:90-96.
2. DeLey, J., and K. Kersters. 1964. Oxidation of aliphatic glycols by acetic acid bacteria. Bacteriol. Rev. 28:164-180.
3. Fincher, E. L., and W. J. Payne. 1962. Bacterial utili-

- zation of ether glycols. *Appl. Microbiol.* **10**:542-547.
4. **Furuya, A., and J. A. Hayashi.** 1963. Glycolic acid oxidation by *Escherichia coli* adapted to glycolate. *J. Bacteriol.* **85**:1124-1131.
 5. **Gaston, W. L., and E. R. Stadtman.** 1963. Fermentation of ethylene glycol by *Clostridium glycalcium* sp. nov. *J. Bacteriol.* **85**:356-362.
 6. **Gonzalez, C. F., W. A. Taber, and M. A. Zeitoun.** 1972. Biodegradation of ethylene glycol by a salt-requiring bacterium. *Appl. Microbiol.* **24**:911-919.
 7. **Hulme, A. C.** 1961. Methods for the determination of organic acids. *Adv. Appl. Microbiol.* **3**:343-393.
 8. **Jones, N., and G. K. Watson.** 1976. Ethylene glycol and polyethylene glycol catabolism by a sewage bacterium. *Biochem. Soc. Trans.* **4**:891-892.
 9. **Kornberg, H. L., and A. M. Gotto.** 1961. The metabolism of C₂ compounds in microorganisms. 6. Synthesis of cell constituents from glycolate by *Pseudomonas* sp. *Biochem. J.* **78**:69-82.
 10. **Krakow, G., and S. S. Barkulis.** 1956. Conversion of glyoxylate to hydroxypyruvate by extracts of *Escherichia coli*. *Biochim. Biophys. Acta* **21**:593-594.
 11. **Lowry, O. H., N. J. Rosebrough, A. L. Farr, and R. J. Randall.** 1951. Protein measurement with the Folin phenol reagent. *J. Biol. Chem.* **193**:265-275.
 12. **Ornston, L. N., and M. K. Ornston.** 1969. Regulation of glyoxylate metabolism in *Escherichia coli* K-12. *J. Bacteriol.* **98**:1098-1108.
 13. **Payne, W. J., and R. L. Todd.** 1966. Flavin-linked dehydrogenation of ether glycols by cell-free extracts of a soil bacterium. *J. Bacteriol.* **91**:1533-1536.
 14. **Sagers, R. D., and I. C. Gunsalus.** 1961. Intermediary metabolism of *Diplococcus glycinophilus*. I. Glycine cleavage and one-carbon interconversion. *J. Bacteriol.* **81**:541-549.
 15. **Tiedje, J. M., B. B. Mason, C. B. Warren, and E. J. Malec.** 1973. Metabolism of nitrilotriacetate by cells of *Pseudomonas* species. *Appl. Microbiol.* **25**:811-818.
 16. **Wolf, J.** 1955. Nichtfluchtige Mono-, Di- und Tricarbonsauren, p. 478-538. In K. Paech and M. V. Tracey (ed.) *Moderne Methoden der Pflanzenanalyse*, vol. 2. Springer-Verlag, Berlin.
 17. **Zelitch, J., and S. Ochoa.** 1953. Oxidation of glycolic and glyoxylic acids in plants. I. Glycolic acid oxidase. *J. Biol. Chem.* **201**:707-718.
 18. **Zweig, G., and J. Sherma (ed.).** 1972. Handbook of chromatography, vol. 1, p. 299. CRC Press, Cleveland, Ohio.