



US008882082B2

(12) **United States Patent**
Abu-Odeh et al.

(10) **Patent No.:** **US 8,882,082 B2**
(45) **Date of Patent:** ***Nov. 11, 2014**

(54) **TENSION GUARDRAIL TERMINAL**

(75) Inventors: **Akram Y. Abu-Odeh**, College Station, TX (US); **Dean C. Alberson**, Bryan, TX (US); **Roger P. Bligh**, College Station, TX (US); **D. Lance Bullard, Jr.**, College Station, TX (US); **C. Eugene Buth**, Wellborn, TX (US)

(73) Assignee: **The Texas A&M University System**, College Station, TX (US)

(*) Notice: Subject to any disclaimer, the term of this patent is extended or adjusted under 35 U.S.C. 154(b) by 856 days.

This patent is subject to a terminal disclaimer.

(21) Appl. No.: **12/946,174**

(22) Filed: **Nov. 15, 2010**

(65) **Prior Publication Data**
US 2011/0057160 A1 Mar. 10, 2011

Related U.S. Application Data

(63) Continuation of application No. 12/115,194, filed on May 8, 2008, now Pat. No. 7,883,075.

(51) **Int. Cl.**
E01F 15/04 (2006.01)
E01F 15/14 (2006.01)

(52) **U.S. Cl.**
CPC **E01F 15/143** (2013.01)
USPC **256/13.1**

(58) **Field of Classification Search**
USPC 256/13.1, 64; 404/6, 9, 10; 52/148, 166
See application file for complete search history.

(56) **References Cited**

U.S. PATENT DOCUMENTS

3,519,301 A 7/1970 Somnitz
4,928,928 A 5/1990 Buth et al.
(Continued)

FOREIGN PATENT DOCUMENTS

WO WO 00/32878 6/2000 E01F 15/00
WO WO 00/40805 7/2000 E01F 15/04
(Continued)

OTHER PUBLICATIONS

Road Systems, Inc., "How the SKT Functions," <http://www.roadsystems.com/skt.htm>, 3 pages, printed May 1, 2008.

(Continued)

Primary Examiner — Joshua Kennedy

(74) *Attorney, Agent, or Firm* — Baker Botts L.L.P.

(57) **ABSTRACT**

A terminal portion of a guardrail safety system includes a terminal portion of a guardrail beam having a downstream end and upstream end. The terminal portion of the guardrail beam slopes from a height appropriate for redirecting an errant vehicle to a height proximate the surface of the ground at an upstream end of the terminal portion. Support posts are installed adjacent a roadway in spaced apart relation to one another and are coupled to the terminal portion of the guardrail beam. A terminal support post is installed adjacent the roadway at an upstream end of the terminal portion of the guardrail beam. The terminal support post couples to an upstream end of the terminal portion of the guardrail beam by a resistive, tensile coupling that maintains tension in the terminal portion of the guardrail beam. The resistive, tensile coupling is maintained between the terminal support post and the guardrail beam during an end-on or re-directive impact by a vehicle. However, the resistive, tensile coupling between the terminal support post and the guardrail beam is released during a reverse-direction impact.

35 Claims, 7 Drawing Sheets

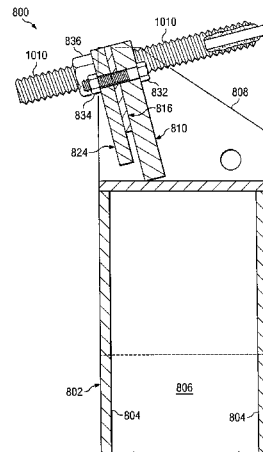
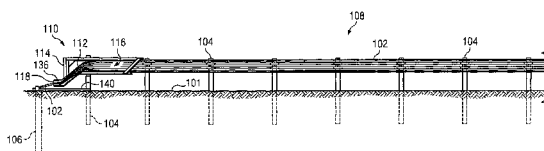

(56)

References Cited

U.S. PATENT DOCUMENTS

5,022,782 A 6/1991 Gertz et al.
 5,078,366 A 1/1992 Sicking et al.
 5,348,416 A 9/1994 Ivey et al.
 5,407,298 A 4/1995 Sicking et al.
 5,503,495 A 4/1996 Mak et al.
 5,797,591 A 8/1998 Krage
 5,931,448 A 8/1999 Sicking et al.
 5,988,598 A 11/1999 Sicking et al.
 6,065,738 A 5/2000 Pearce et al.
 6,089,782 A 7/2000 Bligh et al.
 6,142,452 A 11/2000 Denman et al.
 6,488,268 B1 12/2002 Albritton
 6,554,256 B2 4/2003 Ochoa
 6,715,735 B2 4/2004 Bligh et al.
 6,719,483 B1 4/2004 Welandsson
 6,729,607 B2 5/2004 Alberson et al.
 6,783,116 B2 8/2004 Albritton
 6,902,150 B2 6/2005 Alberson et al.
 6,932,327 B2* 8/2005 Alberson et al. 256/13.1
 7,086,805 B2 8/2006 Smith et al.
 7,185,882 B2 3/2007 Buth et al.
 7,364,137 B2* 4/2008 Neusch 256/13.1
 7,367,549 B2 5/2008 Titmus
 7,401,996 B2 7/2008 Neusch
 7,556,242 B2* 7/2009 Alberson et al. 256/13.1
 7,694,941 B2 4/2010 Abu-Odeh et al.
 7,798,741 B2* 9/2010 Neusch 404/6
 7,883,075 B2* 2/2011 Abu-Odeh et al. 256/13.1
 2002/0066896 A1 6/2002 Bligh et al.
 2002/0179894 A1 12/2002 Albritton
 2003/0025112 A1 2/2003 Sicking et al.
 2004/0041140 A1 3/2004 Johansson et al.
 2006/0017048 A1 1/2006 Alberson et al.
 2006/0043353 A1 3/2006 Titmus
 2006/0102884 A1 5/2006 Rohde et al.
 2007/0147957 A1 6/2007 Buth et al.

2007/0252124 A1 11/2007 Heimbecker
 2008/0142770 A1* 6/2008 Neusch 256/13.1
 2008/0283807 A1 11/2008 Titmus

FOREIGN PATENT DOCUMENTS

WO WO 02/29162 4/2002 E01F 15/14
 WO WO 03/064772 8/2003 E01F 15/04
 WO WO 2010/139027 12/2010

OTHER PUBLICATIONS

Road Systems, Inc., "How the FLEAT Functions," <http://www.roadsystems.com/fleat.htm>, 3 pages, printed May 1, 2008.
 Road Systems, Inc., "X-Tension, Fully Re-Directive, Non-Gating Guardrail End Terminal," <http://www.roadsystems.com/x-tension.htm>, 2 pages, printed May 1, 2008.
 Notification of Transmittal of the International Search Report and the Written Opinion of the International Searching Authority, Int. Application No. PCT/US2009/042850, 15 pages, Aug. 21, 2009.
 First Substantive Report from Examiner regarding Chilean Patent Application No. 1078-2009; with foreign associate comments; 12 pages, Feb. 14, 2011.
 Intellectual Property Office of New Zealand, Examination Report for Patent Application No. 589467, received by Baker Botts from Foreign Associate on Dec. 18, 2011, 2 pages.
 State of Israel Ministry of Justice, Notification of Defects in Israeli Patent Application No. 209183—3 pages, Translation of the Israeli Notification—2 pages, transmitted to Baker Botts by Foreign Associate on Dec. 4, 2012.
 State Intellectual Property Office of the People's Republic of China, The First Office Action, Application No. 200980126179.2, Chinese Office Action—5 pages, Translation of the Chinese Office Action—5 pages, transmitted to Baker Botts by Foreign Associate on May 25, 2012.

* cited by examiner

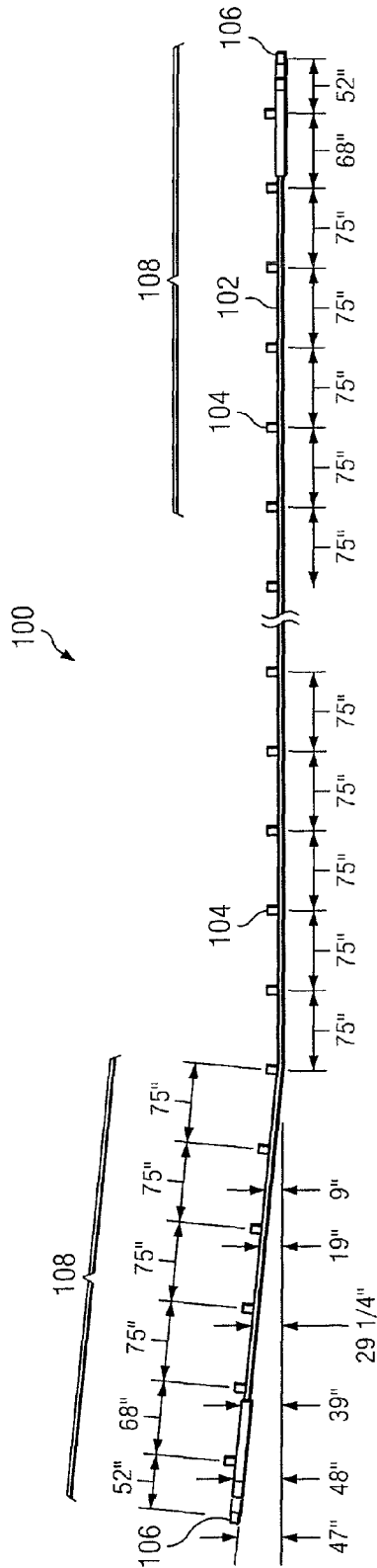

FIG. 1

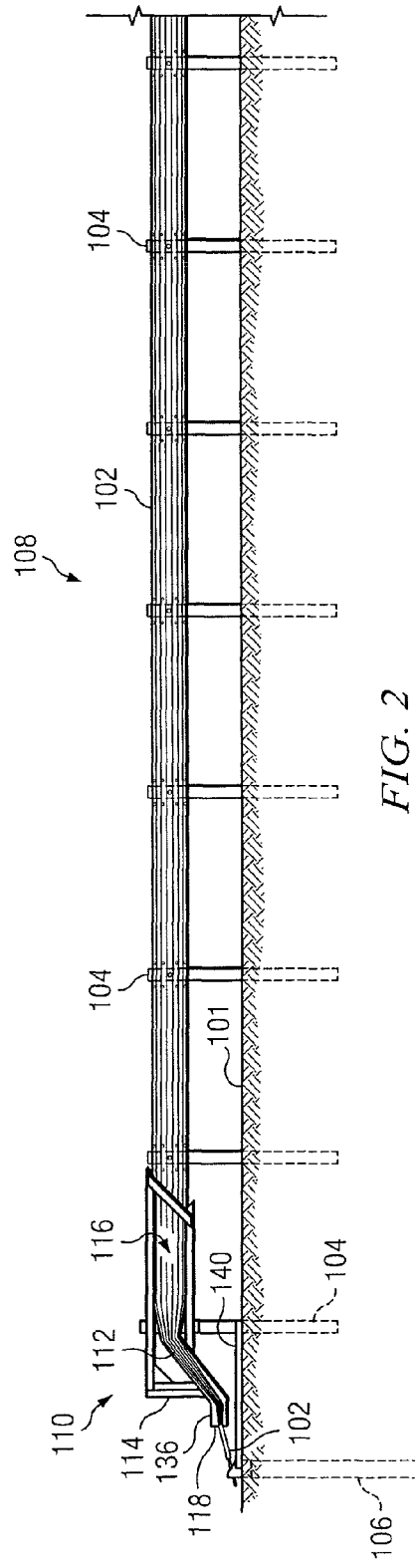

FIG. 2

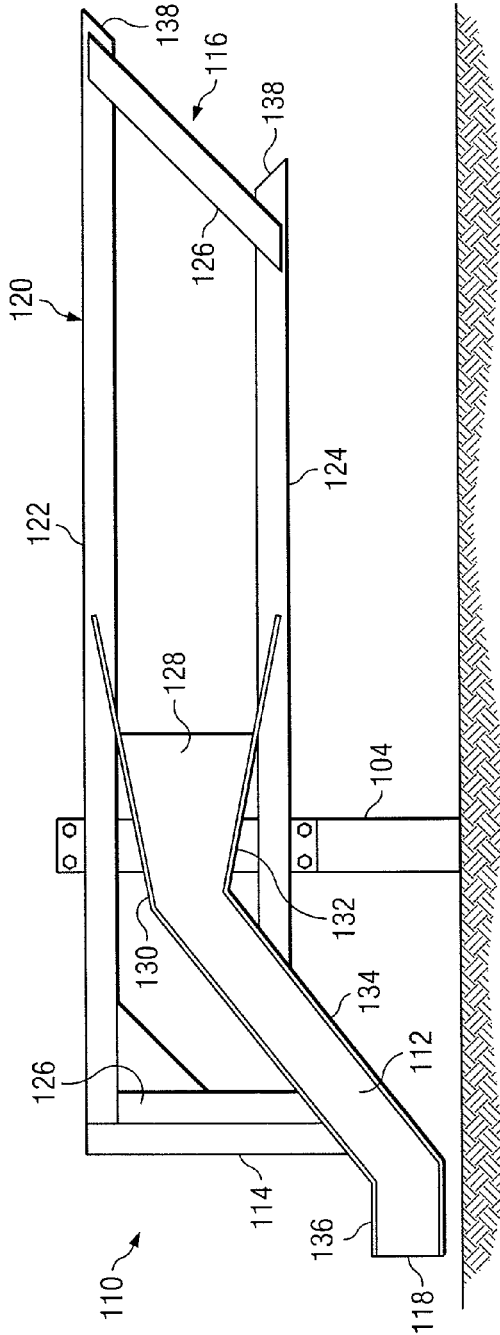

FIG. 3

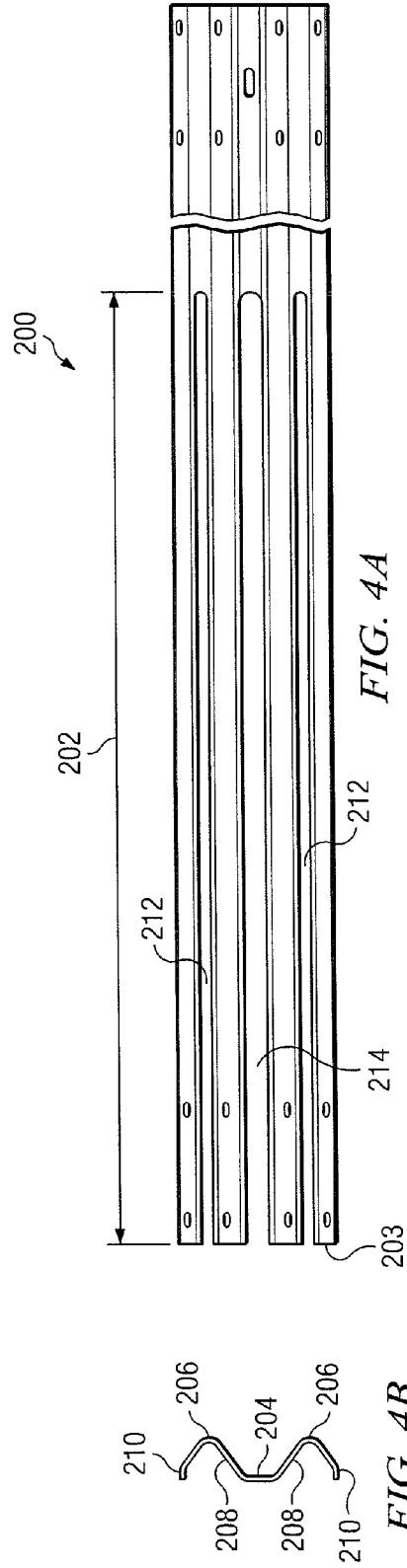
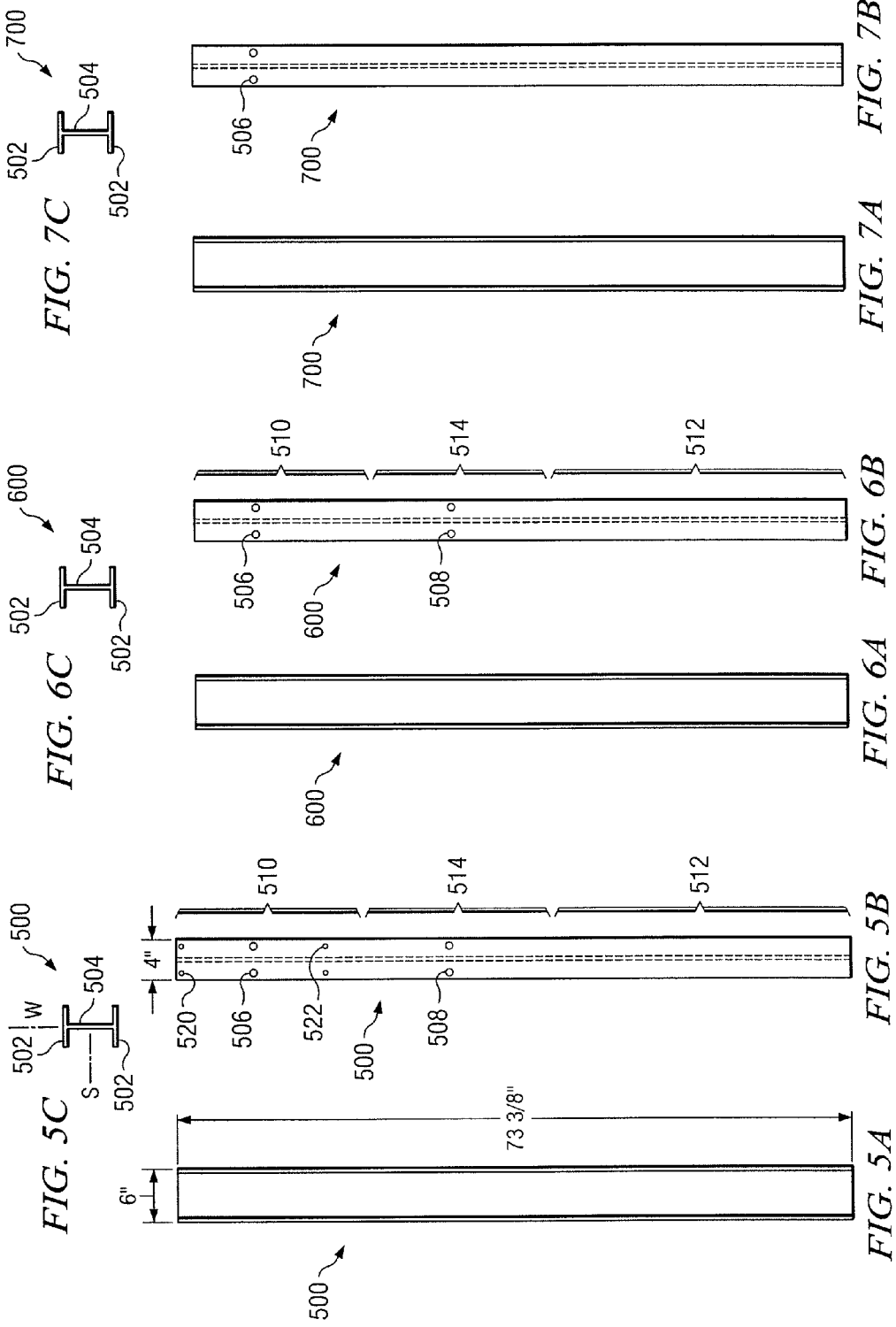

FIG. 4A

FIG. 4B



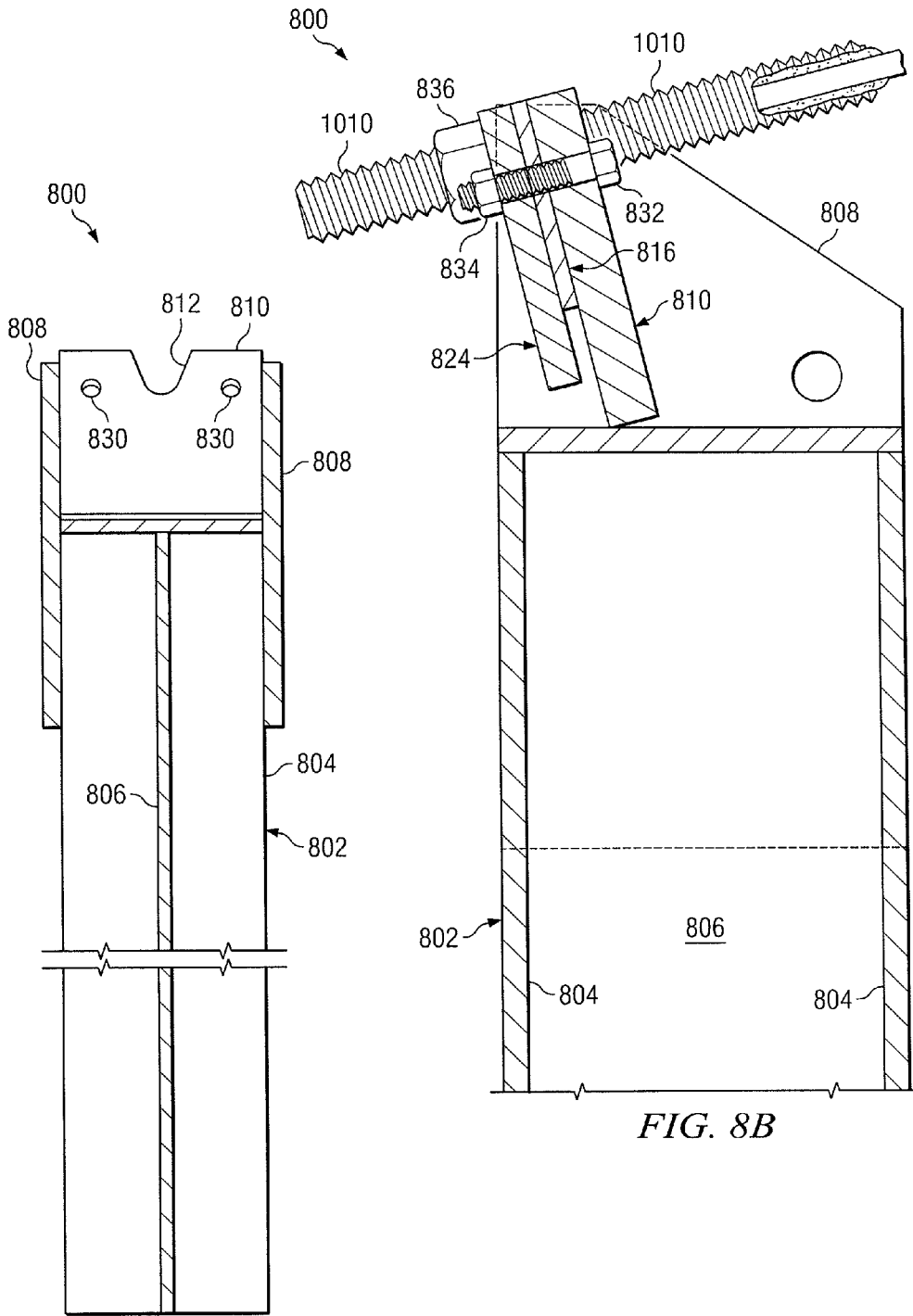

FIG. 8A

FIG. 8B

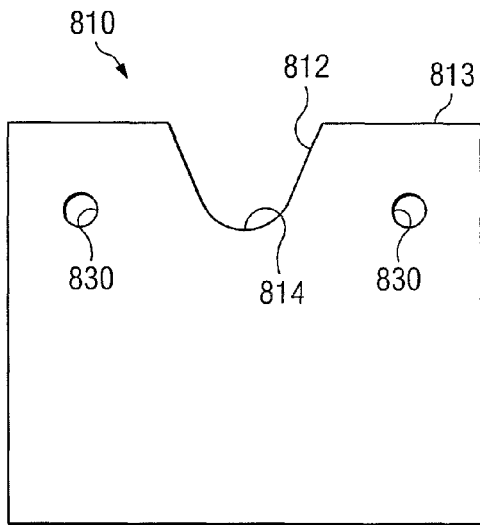

FIG. 9A

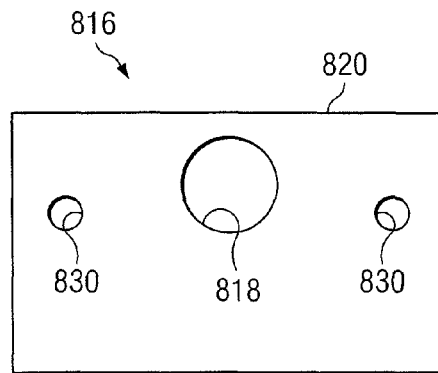

FIG. 9B

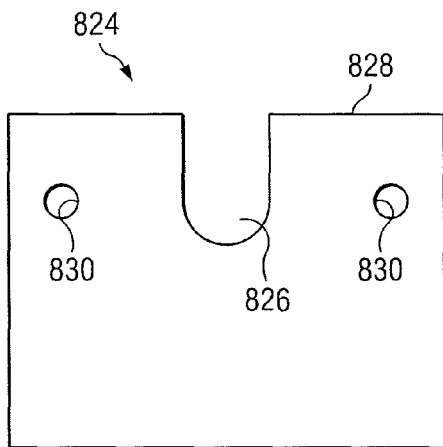

FIG. 9C

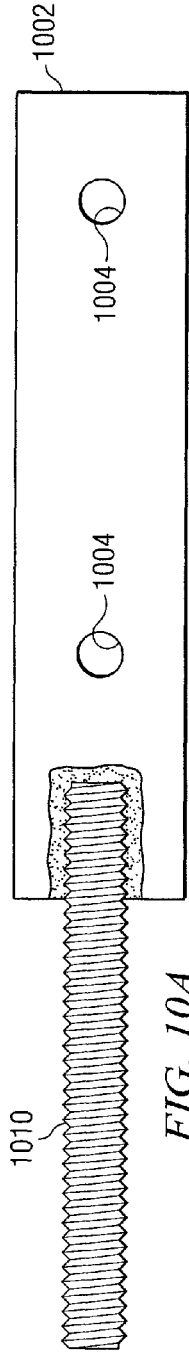

FIG. 10A

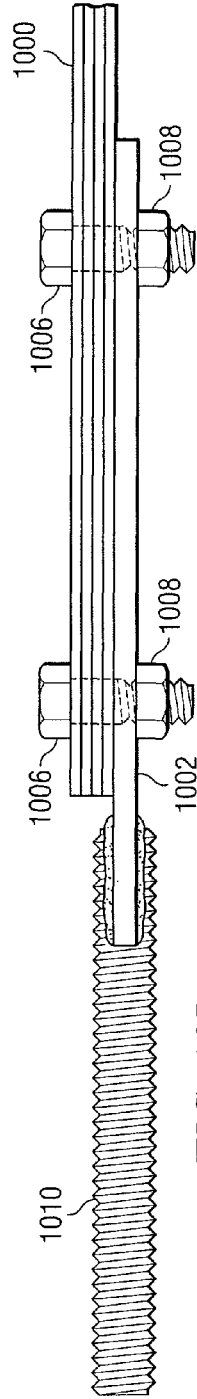

FIG. 10B

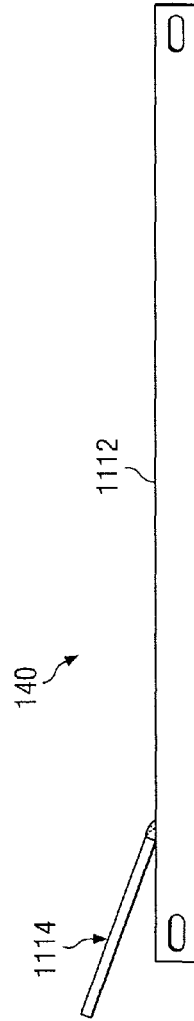

FIG. 11A

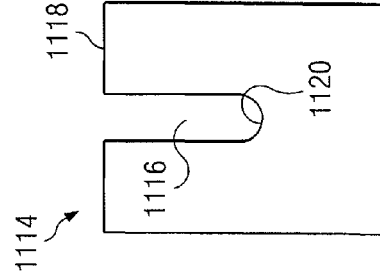

FIG. 11B

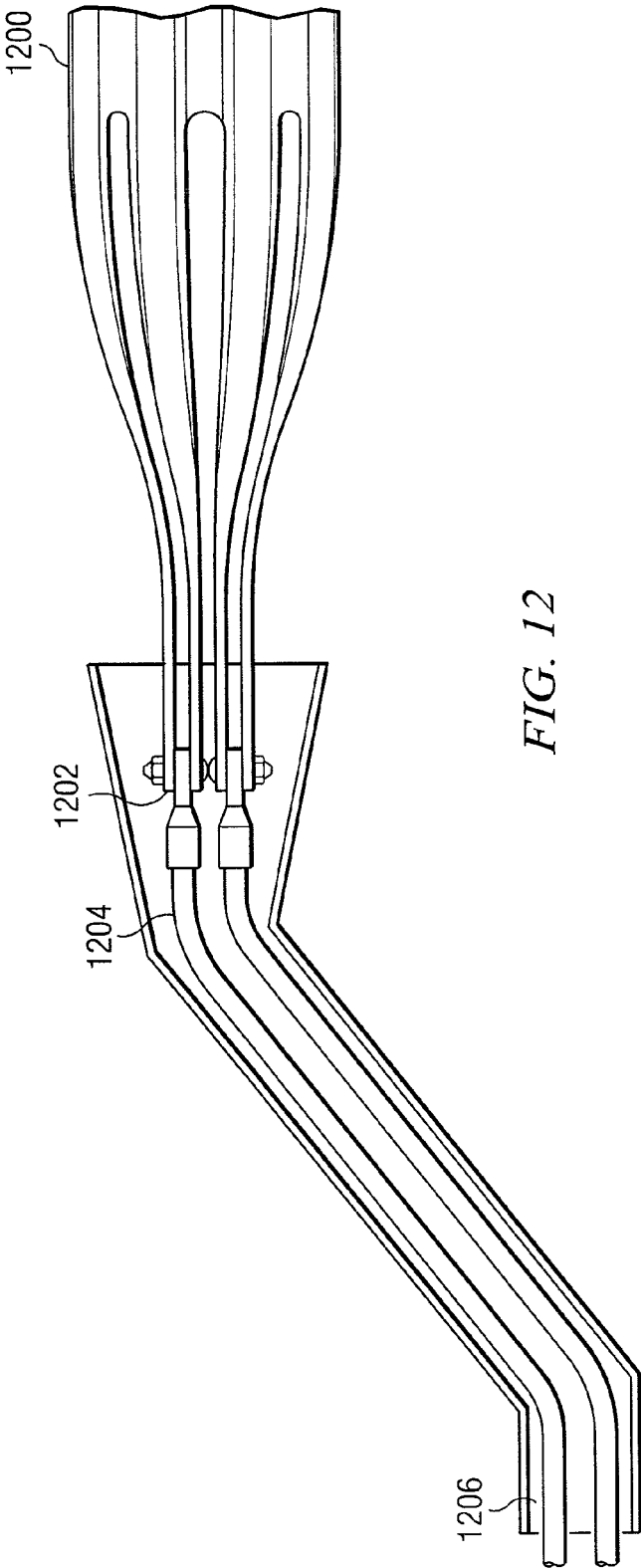

FIG. 12

TENSION GUARDRAIL TERMINAL

RELATED APPLICATIONS

This application is a continuation of U.S. patent application Ser. No. 12/115,194, entitled "Tension Guardrail Terminal," which was filed on May 5, 2008. U.S. patent application Ser. No. 12/115,194 is hereby incorporated by reference.

TECHNICAL FIELD

The present invention relates generally to safety treatment for the ends of W-beam guardrails; and more particularly, to a tensioned guardrail terminal for dissipating impact energy of a car colliding with the end of the W-beam guardrail in an end-on or re-directive impact.

BACKGROUND

Along most highways there are hazards that can be a substantial danger to drivers of automobiles if the automobiles leave the highway. To reduce the severity of accidents due to vehicles leaving a highway, guardrails are provided. The guardrails are installed such that the beam elements are in tension to aid in re-directive type impacts. Guardrails must be installed, however, such that the terminal end of the guardrail facing the flow of traffic is not a hazard. Early guardrails had no proper termination at the ends, and it was not uncommon for impacting vehicles to become impaled on the guardrail causing intense deceleration of the vehicle and severe injury to the occupants. In some reported cases, the guardrail penetrated directly, into the occupant compartment of the vehicle fatally injuring the occupants.

Upon recognition of the problem of proper guardrail termination, guardrail designs were developed that used box beams and W-beams that allow tapering of the end of the guardrail into the ground. Such designs eliminate any spear- ing effect. While these end treatments successfully removed the danger of the vehicle being penetrated in a head-on collision, it was discovered that these end treatments operate in a ramp-like fashion and may induce launching of the vehicle causing it to become airborne for a considerable distance with the possibility of roll over.

In search for better end treatments, improved energy absorbing end treatments for W-beam guardrail elements were developed. For example, an extruder terminal was developed and typically includes a bending structure that squeezes the guardrail into a flat plate and then bends it about a circular arc directed away from the impacting vehicle. Example extruder terminal products include the ET 2000™ and the ET-PLUS™ offered by Trinity Highway Products. Other extruder terminal products include the SKT 350™ and FLEAT 350™ offered by Road Systems, Inc.

All of these energy absorbing systems use a cable to connect the first w-beam guardrail segment to the first post in the system. The cable provides tension in the guardrail beam element for a redirective hit along the length-of-need portion of the guardrail. A number of cable releasing posts have also been developed for use in these terminals. The cable release posts are intended to release the cable anchor and, thus, release the tension in the system when the post is impacted in either of a forward (end-on) or reverse direction. Such systems are not able to remain in tension during end-on and reverse-direction type impacts.

SUMMARY OF THE INVENTION

The present invention provides a new and improved end treatment for highway guardrails.

In accordance with a particular embodiment of the present invention, a terminal portion of a guardrail safety system includes a terminal portion of a guardrail beam having a downstream end and upstream end. The terminal portion of the guardrail beam slopes from a height appropriate for redirecting an errant vehicle to a height proximate the surface of the ground at an upstream end of the terminal portion. Support posts are installed adjacent a roadway in spaced apart relation to one another and are coupled to the terminal portion of the guardrail beam. A terminal support post is installed adjacent the roadway at an upstream end of the end terminal. The terminal support post couples to an upstream end of the terminal portion of the guardrail beam by a resistive, tensile coupling that maintains tension in the terminal portion of the guardrail beam. The resistive, tensile coupling is maintained between the terminal support post and the guardrail beam during an end-on or re-directive impact by a vehicle. However, the resistive, tensile coupling between the terminal support post and the guardrail beam is released during a reverse-direction impact.

Technical advantages of particular embodiments of the present invention include a guardrail end treatment that dissipates impact energy through the compression of a W-beam guardrail element. Thus, one advantage may be that the guardrail end treatment is energy absorbing. Another advantage may be that the end treatment forces the W-beam guardrail element through a flattening structure that squeezes the guardrail into a relatively flat plate. Specifically, the guardrail end treatment may dissipate impact energy of a vehicle colliding with an end of a guardrail by flattening a portion of the guardrail.

Still another advantage may be that an end of the W-beam guardrail element extends through the flattening structure and tapers to the ground. The W-beam guardrail element may be secured to the ground in tension. The components of the system that provide the tensile connection of the guardrail beam to the terminal support post may enable the guardrail beam to remain secured after an end-on or re-directive impact. Thus, the system may remain in tension during both types of impacts. Still another advantage may be that the tension is released when the system is impacted in the reverse direction near the terminal end, however. The releasing of tension in the guardrail element for reverse direction impacts prevents vehicle instability and excessive deceleration.

Other technical advantages will be readily apparent to one skilled in the art from the following figures, descriptions and claims. Moreover, while specific advantages have been enumerated above, various embodiments may include all, some or none of the enumerated advantages.

BRIEF DESCRIPTION OF THE DRAWINGS

FIG. 1 illustrates a top view of an exemplary guardrail safety system that incorporates certain aspects of the present invention;

FIG. 2 illustrates a side view of a terminal portion of a guardrail system that incorporates certain aspects of the present invention;

FIG. 3 illustrates a side view of an exemplary embodiment of an end treatment in the terminal portion of a guardrail system, in accordance with a particular embodiment of the present invention;

FIGS. 4A and 4B illustrate a side view and a profile view, respectively, of a modified guardrail beam that incorporates certain aspects of the present invention;

FIGS. 5A-5C illustrate an exemplary weakened support post suitable for use in a guardrail safety system, in accordance with a particular embodiment of the present invention;

FIGS. 6A-6C illustrates another exemplary weakened support post suitable for use in a guardrail safety system, in accordance with a particular embodiment of the present invention;

FIGS. 7A-7C illustrates an exemplary unmodified support post suitable for use in a guardrail safety system, in accordance with a particular embodiment of the present invention;

FIGS. 8A and 8B illustrate an exemplary embodiment of a terminal support post for use in a guardrail safety system, in accordance with a particular embodiment of the present invention;

FIGS. 9A-9C illustrate various components of a resistive, tensile connection for connecting a guardrail beam to a terminal support post, in accordance with a particular embodiment of the present invention;

FIGS. 10A and 10B illustrate an exemplary resistive, tensile connection for connecting a guardrail beam to a terminal support post, in accordance with a particular embodiment of the present invention;

FIGS. 11A and 11B illustrate an exemplary strut for use in a guardrail safety system, in accordance with a particular embodiment of the present invention; and

FIG. 12 illustrates an alternative embodiment of a resistive, tensile connection for connecting a guardrail beam to a terminal support post, in accordance with a particular embodiment of the present invention.

DETAILED DESCRIPTION OF EXAMPLE EMBODIMENTS

Existing guardrail end treatments have proven to be unsafe for some collision conditions that happen on the highway, sensitive to installation details, and/or very costly. However, the end treatment described below is a safety treatment for the ends of a W-beam guardrail that provides a higher level of performance over a wider range of collision conditions and reduces end treatment costs and the number of injuries and deaths associated with guardrail terminal accidents. The described system maintains the tension in the guardrail beam element during both end-on and re-directive type impacts. When the system is impacted in the reverse direction near the terminal end, however, the anchorage system may release to prevent vehicle instability or excessive deceleration.

FIG. 1 illustrates a guardrail safety system 100 that incorporates certain aspects of the present invention. Guardrail system 100 may be installed adjacent a roadway 101, to protect vehicles, drivers and passengers from various obstacles and hazards, and prevent vehicles from leaving the roadway 101 during a traffic accident or other hazardous condition. Guardrail systems that incorporate aspects of the present invention may be used in median strips or shoulders of highways, roadways, or any path that is likely to encounter vehicular traffic.

Guardrail system 100 includes a guardrail beam 102 and support posts 104 that anchor guardrail beam 102 in place along the roadway 101. In a particular embodiment, guardrail beam 102 may include multiple 12-gauge W-beam rail elements of a length on the order of approximately 12.5 feet or 25 feet. The guardrail beam sections may be mounted at a height of on the order of approximately 27 to 31 inches with rail splices positioned mid-span between the support posts 104. Guardrail beam 102 and the terminal end of guardrail beam 102, specifically, are illustrated in more detail in FIGS. 4A and 4B and will be described below.

Guardrail beam 102 is attached to support posts 104 with connectors that may include, in particular embodiments, slotted countersunk bolts such as, for example, 16 mm (5/8-inch) diameter by 38 mm (1 1/2-inch) long flat slot machine screws.

Oversized guardrail nuts may be used on the back side of the support post 104. Support posts 104 may be embedded in the ground, a concrete footing, or a metal socket. Support posts 104 may be made of wood, metal, plastic, composite materials, or any combination of these or other suitable materials. It is also recognized that each support post 104 within guardrail system 100 need not necessarily be made of the same material or include the same structural features. Furthermore, the cross-section of support posts 104 may be any engineered shape suitable for releasably supporting guardrail beam 102. Such cross-sectional shapes may include, but are not limited to, square, rectangular, round, elliptical, trapezoidal, solid, hollow, closed, or open.

Guardrail system 100 is intended to keep errant vehicles from leaving roadway 101 during a crash or other hazardous situation. In many instances, guardrail 100 is installed between roadway 101 and a significant hazard to vehicles (e.g., another roadway, a bridge, cliff, etc.). Therefore, guardrail system 100 should be designed to withstand a significant impact from a direction generally perpendicular to roadway 101, without substantial failure. It is this strength that allows guardrail system 100 to withstand the impact, and still redirect the vehicle so that it is once again traveling generally in the direction of roadway 101.

However, testing and experience has continuously shown that guardrail systems may actually introduce additional hazards to the roadway and surrounding areas. This is particularly true with respect to vehicles that impact the guardrail system adjacent its terminal section, in a direction generally parallel to the roadway. For example, if the guardrail system were rigidly fixed in place during a crash, serious injury and damage may result to the errant vehicle, its driver and passengers. Accordingly, many attempts have been made to minimize this added risk. Such methods generally include the use of terminal portions that are tapered from the ground up to effectively reduce the impact of head on collisions and to create a ramp-like effect that causes vehicles to go airborne during a crash. Other methods include breakaway cable terminals (BCT), vehicle attenuating terminals (VAT), SENTRE end treatments, breakaway end terminals (BET) and the breakaway support posts of U.S. Pat. No. 6,398,192 ("192 Patent"). Many such terminals, supports, end treatments and the like are commercially available from various organizations. Examples include the HBA post by Exodyne Technologies and Trinity Industries, and a breakaway support post similar in configuration to that described in the '192 Patent.

Referring again to FIGS. 1 and 2, guardrail system 100 includes one terminal post 106 and seven support posts 104. Collectively, this configuration forms a terminal section 108 of guardrail system 100. As shown, terminal section 108 is employed in a preferred embodiment as an end terminal for a conventional guardrail assembly 100.

Although FIG. 1 is illustrated with dimensions and depicts one exemplary embodiment, it is understood that the dimensions of guardrail system 100 may vary depending on the nature of the roadside hazard being shielded. As illustrated, each terminal section 108 has a length on the order of approximately 35 feet. However, the dimensions of terminal section 108 may vary as needed. Additionally, the length of the length-of-need portion of the system may of any appropriate length required by the conditions of roadway 101.

Terminal section 108 may be installed either parallel to roadway 101 or at an angular departure from roadway 101, as

5

shown best in FIG. 1. Additionally, while the terminal section 108 at one end of the guardrail safety system may be flared, the terminal section 108 at the opposite end of the system may not be flared, in certain embodiments. For example, in the embodiment depicted in FIG. 1, an upstream terminal section 108 is flared while a downstream terminal section 108 is not flared. Specifically, the upstream terminal sections 108 is flared away from roadway 101 in a substantially linear manner while the downstream terminal section 108 remains substantially parallel to the roadway. In other embodiments, both terminal sections 108 may be flared or unflared in a similar manner. Additionally, it is recognized that other configurations may be used for terminal sections 108. For example, one or both of terminal sections 108 may be installed at a parabolic flare away from the roadway. A parabolic flare may be accomplished by increasing the offset of each support post in a generally parabolic progression as the terminal portion proceeds upstream. Where incorporated, positioning of one or more of terminal sections 108 at a flared or angular departure away from roadway 101 may permit the terminal sections 108 to perform a gating function by facilitating movement of the impacting vehicle to the side of the rail opposite roadway 101 as the vehicle progresses.

In a particular embodiment where terminal section 108 is linearly flared, terminal section 108 may be flared back at an angle of approximately 6 to 7 degrees from the non-terminal portion of the guardrail. Where support posts 104 of terminal section 108 are spaced apart at intervals of approximately 75 inches, the most downstream post 104 of terminal section 108 may be approximately 9 inches offset from a line tangent to the non-terminal portion of the guardrail, in a particular embodiment. Moving toward the upstream end of terminal section 108, the next four successive support posts 104 may be 19, 29, 25, 39, and 48 inches offset from a line tangent to the non-terminal portion of the guardrail, in this embodiment. Terminal post 106, which may be positioned directly below guardrail beam 102, may be approximately 47 inches offset from a line tangent to the non-terminal portion of the guardrail, in the described embodiment.

As shown better in FIG. 2, terminal section 108 includes an end treatment 110. End treatment 110 includes a flattening chute 112 and a front striking plate 114. End treatment 110 and flattening chute 112, specifically, is mounted onto a first post 104 by fasteners such as bolts. The purpose of end treatment 110 is to dissipate impact energy of the vehicle without creating a dangerous condition such as causing the vehicle to roll-over or allow the guardrail 102 to spear the vehicle or the occupant compartment of the vehicle.

Guardrail beam element 102 feeds into an inlet 116 at a downstream end of flattening chute 112. Guardrail beam element 102 is disposed within flattening chute 112 and extends the length of flattening chute 112. Guardrail beam element 102 exits an outlet 118 at an upstream end of flattening chute 112. As will be described in more detail with regard to FIG. 3, the dimensions of flattening chute 112 results in a terminal portion of the guardrail beam 102 tapering to the ground. The portion of guardrail beam element 102 exiting outlet 118 is flattened vertically such that the terminal portion of guardrail beam element 102 resembles a stack of four flat plates.

A terminal post 106 secures the terminal end of guardrail beam element 102 to the ground and places guardrail beam element 102 in tension. As will be described in more detail with regard to FIGS. 8A and 8B and 10A and 10B, the coupling of guardrail beam element 102 to terminal post 106 enables guardrail beam element 102 to remain secured in tension to terminal post 106 after either of an end-on or re-directive impact by a vehicle leaving roadway 101. How-

6

ever, the components effecting the tensile coupling enables the tension in guardrail beam element 102 to be released when the system is impacted in the reverse direction near the terminal end. The releasing of tension in the guardrail element for reverse direction impacts prevents vehicle instability and excessive deceleration.

FIG. 3 illustrates an exemplary embodiment of end treatment 110 in greater detail. As described above, end treatment 110 includes a flattening chute 112 and a front striking plate 114. Flattening chute 112 and front striking plate 114 are coupled to an extruder 120. Extruder 120 surrounds the upstream portion of guardrail beam member 102 and is made up of an upper, U-shaped channel member 122 and a lower, U-shaped channel member 124, which are secured in a spaced relation to one another by strap plates 126.

The vertical distance between channel members 122 and 124 is an appropriate distance such that guardrail beam 102 is inserted into the channel created by extruder 120. For example, where guardrail beam 102 comprises a 12-gauge W-beam rail element having a vertical dimension of approximately 12.25 inches, the distance between the top of channel member 122 and the bottom of channel 124 may be approximately 14 inches, in a particular embodiment.

Front striking plate 114 is secured by welding to extruder 120 of end treatment 110. Front striking plate 114 may be vertically elongated, in particular embodiments. Thus, front striking plate 114 may extend both above and below extruder 120 to permit front striking plate 114 to be easily engaged by either the high bumper of trucks, SUV's, and other taller vehicles and the low set bumpers of smaller cars impacting in a frontal manner. Front striking plate 114 is also positioned so as to engage the vehicle frame or rocker panel to reduce vehicle intrusion when the upstream end of end treatment 110 is impacted by a vehicle in a sideways manner.

Flattening portion 112, which is mounted to extruder 120, may be constructed from four metal plates, in a particular embodiment. The four metal plates may be cut and/or bent and then welded together to form the desired configuration. Alternatively, flattening portion 112 may be formed from more than four pieces or from a single piece of metal that is cut and bent into the desired configuration. When flattening portion 112 is assembled, flattening portion 112 may form an enclosed structure that houses a terminal portion of guardrail beam 102.

In the illustrated embodiment, flattening portion 112 includes three sections. The most downstream portion of flattening portion 112 includes a throat 128. The vertical dimension of throat 128 is greater at the downstream end and decreases as it approaches the upstream end of end treatment 110. For example, in a particular embodiment, the vertical dimension of throat 128 may be approximately 14 inches wide at the downstream end and approximately 4.5 inches wide at the upstream end. The horizontal length of throat 128 may be within a range of approximately 11 to 13 inches.

In a particular embodiment, the slope of a lower edge 132 may be greater than the slope of an upper edge 130. The increased slope of lower edge 132 may aid in the flattening of guardrail beam 102 during an impact. For example, in a particular embodiment, upper edge 130 may slope upward at an angle of approximately 11 degrees from the horizontal, and lower edge 132 may slope downward at an angle of approximately 13 degrees from the horizontal. In still other embodiments, the slope of upper edge 130 and lower edge 132 may be substantially the same. Thus, in a particular embodiment, upper edge 130 and lower edge 132 may symmetrically mirror one another. In still other embodiments, one of top edge 130 and lower edge 132 may be aligned with the

horizontal (substantially parallel with the roadway) while the other of top edge **130** and lower edge **132** slopes upward or downward, respectively.

A mid portion **134** extends from the upstream end of throat **128** and slopes toward the ground. Specifically, mid portion **134** is configured to transition guardrail beam element **102** from a height above the ground level that is appropriate for redirecting an impacting vehicle (31 inches, in a particular embodiment) to a height that is proximate the ground's surface. Thus, mid portion **134** extends from a vertical distance associated with throat **128** at a downstream end to approximately ground level at an upstream end. In a particular embodiment, where the horizontal length of mid portion **134** is approximately 18.75 inches, mid portion **134** may slope at an angle of approximately 38 degrees from the horizontal.

Mid portion **134** also provides a channel through which a terminal portion of guardrail beam element **102** is disposed. In a particular embodiment, the vertical dimension of the channel within mid portion **134** may be approximately 4.5 inches (similar to the width of throat **128** at the upstream end). The dimensions of the channel within mid portion **134** may remain substantially constant such that the vertical dimension of the channel within mid portion **134** at the downstream end is the substantially the same as the vertical dimension of the channel within mid portion **134** at the upstream end.

A third portion of flattening portion **112** includes outlet portion **136**. Outlet portion **136** extends from the upstream end of mid portion **134**. Outlet portion **136** is disposed proximate the grounds' surface and is in substantial alignment with the grounds' surface. Outlet portion **136** also forms a channel through which the terminal end of guardrail beam element **102** exits the flattening chute **112**. In a particular embodiment, the vertical dimension of the channel within outlet portion **136** may be approximately 4.5 inches (similar to the vertical dimension of the channel within mid portion **134**). The dimensions of the channel within outlet portion **136** may remain substantially constant such that the vertical dimension of the channel at the downstream end of outlet portion **136** is substantially the same as the vertical dimension of the channel at the upstream end of outlet portion **136**. In a particular embodiment, the horizontal length of outlet portion **136** may be approximately 5-7 inches.

As stated above with regard to FIG. 2, guardrail beam member **102** is disposed within and extends throughout the length of flattening portion **112**. Specifically, guardrail beam member feeds into an inlet **116** at a downstream end of flattening chute **112**. Guardrail beam element **102** traverses the length of flattening chute **112** and exits an outlet **118** at an upstream end of flattening chute **112**. Thus, a terminal end of the W-beam guardrail element extends through the flattening structure. The slope of mid portion **134** toward the ground in the upstream direction results in guardrail beam element **102** being gradually transitioned toward the ground over the length of flattening portion **112**. After exiting the outlet **118**, guardrail beam element **102** is secured to a terminal post **106** at ground level.

During an end-on or oblique end-on collision of a vehicle with front striking plate **114**, end treatment **110** may be displaced in a downstream direction and downstream portions of guardrail beam element **102** may be forced into the displaced end treatment **110**. During such a collision, extruder **120** functions as a guide to guide guardrail beam element into flattening portion **112**. Extruder **120** includes guides **138** that prevent shaving of the W-beam guardrail element **102** by ends of extruder **120** as extruder **120** moves along the length of the guardrail beam element **102** during a collision. The guides **138** accommodate any irregularities or bumps in guardrail

beam element **102** to ensure proper feeding of guardrail beam element **102** into flattening portion **112**.

As end treatment **110** moves along guardrail beam element **102** and downstream portions of guardrail beam element **102** are forced into flattening portion **112**, guardrail beam element **102** is flattened vertically. Portions of guardrail beam element **102** exiting outlet **118** of flattening portion **112** are flattened into what may appear to be four vertically stacked plates. For example, where the vertical dimension of guardrail beam element **102** is approximately 12.25 inches and throat portion **134** of flattening portion **112** is approximately 4.5 inches, the vertical dimension of the flattened portion of guardrail beam element **102** may be less than approximately 4.5 inches. As this flattening process occurs, substantial energy is dissipated slowing the impacting vehicle.

To aid in initial flattening of guardrail beam element **102** for coupling to terminal support post **106**, a terminal end of guardrail beam element **102** may be modified. FIGS. 4A and 4B illustrate a modified guardrail beam element **200** in accordance with one embodiment. As shown in FIG. 4A, the guardrail beam element **200** includes a slotted zone **202** at the upstream end of the terminal portion of guardrail beam element **200**. In a particular embodiment, slotted zone **202** comprises a series of slots longitudinally disposed in the guardrail beam element **200**. The use of three slots has proven effective in testing models of guardrails constructed similar to guardrail safety system **100**.

Slotted zone **202** may initiate at a terminal end **203** of guardrail beam element **200** and extend a desired distance downstream. The horizontal length of slotted zone **202** may vary depending on the horizontal length of end treatment **110**. It may be desirable for slotted zone **202** to include the portion of guardrail beam element **200** that is coupled to terminal post **106** and the portion of guardrail beam element **200** that traverses through flattening portion **112**. Generally, slotted zone **202** may extend from the terminal, upstream end of guardrail beam element **200** to some distance between the first and second support posts **104**. Where, for example, the dimensions of the terminal section **108** of guardrail system **100** are similar to those illustrated in FIG. 1, slotted zone **202** may extend approximately 80-85 inches from the terminal end of guardrail beam element **200**.

The placement of the slots in slotted zone **202**, according to a particular embodiment, may be better understood with reference to the cross-section for a typical W-beam guardrail **200** as shown in FIG. 4B. A valley **204** is positioned between upper and lower peaks **206** and is formed at the intersections of inclined web portions **208**. Edge members **210** laterally out lie each peak **206**. Highly preferred placement for the slots is proximate each peak **206** and the valley **204**. Thus, in the illustrated embodiment of FIG. 4A, first and second slots **212** are placed in the first and second peaks **206**, respectively. A third slot **214** is placed in valley **204**.

Slots **212** and **214** should be of a size sufficient to enhance the ability of the terminal end of guardrail beam element **200** to be flattened. In a preferred embodiment, the entire vertical dimension of each peak **206** and valley **204** may be removed. Effective sizes for slots **212** have been found to be approximately 0.5 inches, as measured vertically. An effective size for slot **214** has been found to be approximately 0.75 inches, as measured vertically. Thus, in a particular embodiment, slots **212** may have a width on the order of 0.5 inches and extend approximately 81-82 inches. Slot **214** may have a width on the order of approximately 0.75 inches and extend approximately 81-82 inches. The provided dimensions are for example purposes only, however. Any dimensions may be used for slots **212** and **214** to enhance the ability of guardrail

beam **200** to be flattened into four vertically stacked plates throughout the terminal end of guardrail beam element **200**.

While guardrail beam **102** may include W-beam rail elements, it is generally recognized that the illustrated guardrail beam **102** is merely an example of a beam that may be used in a guardrail system. Guardrail beams **102** or portions of guardrail beams **102** may include conventional W-beam guardrails, their beam guardrails, box beams, wire ropes, or other structural members suitable for redirecting an errant vehicle upon impact. It is also recognized that the configuration and dimensions of any of the above-described elements within guardrail system **100** may vary as desired.

Returning to FIGS. **1** and **2**, following the initial end-on impact of a vehicle with end treatment **110** and the initiation of the displacement of end treatment **110** in a downstream direction, the impacting vehicle and end treatment **110** may engage one or more support posts **104**. Where the support posts **104** comprises steel yielding support posts that are modified at ground level, the impacted support posts **104** may release guardrail beam element **102** as they are impacted and bent toward the ground. Thus, support posts **104** that are impacted during the collision may be displaced, in certain embodiments, such that they do not pose a hazard to the impacting vehicle. Although guardrail beam **102** may be released from impacted support posts **104**, portions of guardrail beam element **102** downstream from the impact may remain in substantially their original position relative to the ground's surface. Further, because guardrail beam **102** remains coupled to terminal post **106** during an end-on or re-directive impact, guardrail beam **102** remains in tension. This extends the range of acceptable performance of guardrail safety system **100**.

The tension in guardrail beam **102** may also be retained in this manner when guardrail system **100** is subject to a re-directive impact in the length of need portion of guardrail system **100**. For example, when an impacting vehicle traveling in a direction substantially parallel to the downstream direction of guardrail system **100** leaves the roadway and impacts guardrail system **100**, any support posts **104** impacted by the vehicle may operate to release guardrail beam element **102** as they are impacted. Modified support posts **104** may be bent toward the ground such that the support posts **104** are displaced and do not pose a hazard to the impacting vehicle. Because the tension in guardrail beam **102** is maintained, guardrail beam element **102** continues to operate to redirect the vehicle back onto the roadway even after one or more support posts are released from guardrail beam element **102**.

FIGS. **5A-5C**, **6A-6C**, and **7A-7C** illustrate example embodiments of support posts that may be used in conjunction with guardrail system **100** of FIG. **1**. Specifically, FIGS. **5A-5C** illustrate an exemplary weakened support post that may be used as a first support post **500** (after the terminal support post **106**) in the terminal section **108** of guardrail safety system **100**. FIGS. **6A-6C** illustrate an exemplary weakened support post **600** that may be used throughout terminal section **108** and other portions of guardrail safety system **100**. FIGS. **7A-7C** illustrate a standard line post **700** that may be used in certain portions of guardrail safety system **100**. Although FIGS. **5A-5C**, **6A-6C**, and **7A-7C** illustrate three distinct embodiments, respectively, like reference numerals have been used to identify parts common to the three embodiments.

As illustrated, support posts **500**, **600**, and **700** include elongate, continuous structural members and are each of a standard wide flange configuration. Each support post includes two flanges **502**, that are generally parallel with one another, and in spaced apart relation from one another. A web

504 forms the coupling between flanges **502**. In a preferred embodiment, flanges **502** include a generally identical configuration of boltholes **506** and cutouts **508**, therein.

With regard to the wide flange shape used as a guardrail post, the cross section is typically shaped like the letter "H". The cross section has two major axes for bending. The "weak" axis generally refers to a central axis that extends through the web and is perpendicular to the flanges. The "strong" axis generally refers to a central axis that is perpendicular to the web and parallel to the planes of the flanges. The weak axis for a conventional installation of guardrail extends generally transversely to the road. The strong axis extends generally along the roadway.

In the illustrated embodiment of FIGS. **5A-5C**, **6A-6C**, and **7A-7C** the wide flange is a standard W6x8.5, which is commonly used in fabricating support posts for guardrail installations. A standard W6x8.5 wide flange may have a nominal six-inch depth and weigh eight and one-half pounds per foot. In fact, one advantage of the present invention is the ability to re-use existing, standard equipment to fabricate, modify, and install support post **500**, without substantial modification to the equipment. Those of ordinary skill in the art will recognize that wide flange beams may be available in many different sizes. For example, a wide flange having a six-inch depth and weighing nine pounds per foot may also be used. Such a wide flange is referred to as a W6x9 wide flange. However, a W6x9 wide flange and a W6x8.5 wide flange are considered equivalent in the trade. The terms "W6x8.5 wide flange" and "W6x9 wide flange" are intended to refer to all sizes and configurations of guardrail posts that may be referred to as "W6x9" by a person of ordinary skill in the art. In addition, persons skilled in the art recognize other names used for wide flanges include but are not limited to "I-beam," "H-beam," "W-beam," "S-beam," "M-beam," or the term "shape" may be substituted for "beam."

Support posts **500**, **600**, and **700** have a length in a range of approximately 72 and 73 $\frac{3}{8}$ inches, in particular embodiments, and include an upper portion **510** and a lower portion **512**. A mid portion **514** couples upper portion **510** with lower portion **512**. Upper portion **510** includes two boltholes **506** that are adapted to receive connectors for the installation of a guardrail beam (e.g., guardrail beam **102**) upon the support post. Lower portion **512** is suitable for installation below grade, as part of a guardrail support system.

Bolt holes **506** include a standard configuration that allow for the installation of widely used guardrail beams, upon the respective support post. In general, bolt holes **506** align with the center of the guardrail beam, and maintain the center of the guardrail beam approximately 30 inches above grade. However, the number, size, location and configuration of boltholes **506** may be significantly modified, within the teachings of the present invention.

Support posts **500** and **600** are each modified to include a relatively "weak" axis W, and a relatively "strong" axis S. Support posts **500** and **600** are normally installed along a roadway such that weak axis W is generally perpendicular to the direction of traffic, and strong axis S is generally parallel to the direction of traffic. Accordingly, support posts **500** and **600** are typically able to withstand a significant impact (e.g., with a car traveling at a high rate of speed) about the strong axis S without substantial failure. However, support posts **500** and **600** are intentionally designed such that failure will more readily occur in response to an impact about the weak axis W. Stated differently, support posts **500** and **600** exhibit adequate strength in the lateral direction but sufficiently low strength in the longitudinal direction. Accordingly, if a vehicle impacts end treatment **110** "end-on", support posts **500** and **600** will

tend to fail (e.g., buckle), while allowing the vehicle to decelerate as it impacts consecutive support posts. However, if a vehicle strikes guardrail system **100** along the face of and at an angle to guardrail beam **102**, support posts **500** and **600** will provide sufficient resistance (strength) to redirect the vehicle along a path generally parallel with guardrail beam **102**.

Mid portions **514** of support posts **500** and **600** include two cutouts **508**, which are configured to further weaken the support posts about the weak axis W, to more readily allow for failure due to impact from a vehicle along that direction. Cutouts **508** are positioned within mid portion **514** to weaken the support posts about weak axis W, adjacent grade (when installed). This will accommodate failure of the support posts approximately at grade, allowing support posts **500** and **600** to “fold” over from the point of failure, upward. Since lower portion **512** is below grade, it is not expected that the ground, or lower portion **512** of the support post will appreciably deflect during an impact.

Since cutouts **508** are intended to occur approximately at grade, and the center of bolt holes **506** are intended to occur 30 inches above grade, bolt holes **506** occur 30 inches above cutouts **508**, in the illustrated embodiment. It will be recognized by those of ordinary skill in the art that the size, configuration, location and number of bolt holes, cutouts, and their relationship with each other, may be varied significantly within the teachings of the present invention. The overall length of the support posts, and their respective upper, lower and mid portions may vary significantly, within the teachings of the present invention. For example, in other embodiments, cutouts **508** may occur below grade or above grade. The depth of cutouts **508** below grade should not exceed an amount that will prevent the support posts from failing at or near the location of cutouts **508**. At some depth below grade, the surrounding earthen (or other) material will reinforce lower portion **512** of the support posts to an extent that will no longer accommodate such failure to occur.

The height of cutouts **508** above grade should not exceed a point at which the support post will fail at cutouts **508**, and leave a “stub” above grade which can snag vehicles, and otherwise cause excessive injury and/or excessive damage. Such a stub could be detrimental to the redirective effect of the guardrail system in which the support post is operating.

The vertical dimension of a cutout **508** is limited based upon the horizontal dimension of cutout **508**. For example, a ratio of the vertical dimension of any particular cutout may be equal to, or less than three times the horizontal dimension. Alternatively, the ratio may be limited to two times the horizontal dimension. In the illustrated embodiments, the ratio is 1:1, since cutout **508** is generally a circular opening in the support post. The smaller the vertical dimension of the cutout, the more precisely the designer may dictate the point of failure along the vertical length of support posts **500** and **600**.

Various configurations of cutouts **508** are available to a designer of support posts **500** and **600**, in accordance with the teachings of the present invention. For example, rather than circular openings, cutouts **508** may comprise square, rectangular, triangular, oval, diamond shaped, or practically any other geometric configuration, and still obtain some or all of the benefits described herein.

The horizontal orientation of cutouts **508** within flanges **502** may also be altered significantly, within the teachings of the present invention. In the illustrated embodiments of FIGS. **5A-5C** and **6A-6C**, the centerline of cutouts **508** is located approximately one inch from the centerline of flanges **508**. However, in alternative embodiments, cutouts **508** may be located closer to such edges, or further from such edges. In

one embodiment, cutouts **508** may be configured such that they extend all the way to the edge of the flange, such that there is a break in material beginning at the edge. In this manner, a traditional punch could be employed at the edge, to form a semi-circular opening that extends to the edge of the flange.

Alternatively, a sawcut could be employed from the outer edge of the flange, and extending inward, to form cutouts **508**. In this manner, the sawcut would form the starting point of the likely point of failure along the weak axis of the support post. Rather than a sawcut, a similar configuration may include a slot in which the longest dimension extends horizontally through the flange. Such a slot may begin or terminate at the edge of the flange, or otherwise be disposed completely within the material of the flange.

As stated above, FIGS. **5A-5C** specifically illustrate a guardrail support post **500** that may be used as the first support post (after the terminal support post **106**) in a guardrail system **100**. Where an end treatment such as end treatment **110** is incorporated into guardrail safety system **100**, support post **500** may be modified to support an end treatment **110**. Specifically, support post **500** includes additional boltholes **520** and **522** for coupling end treatment **110** to support post **500**. In the particular illustrated embodiment, boltholes **520** and **522** are slightly smaller than boltholes **506** and cutouts **508**. It is recognized, however, that the provided dimensions of boltholes **520** and **522** are provided for example purposes only and may vary as appropriate for coupling the end treatment **110** to support post **500**. In contrast to support post **500**, support posts **600** and **700** do not include additional boltholes **520** and **522** and, thus, are more appropriately used in portions of the guardrail system **100** that are not directly supporting end treatment **110**.

Although **W6x8.5** wide flanges are described above and illustrated within this specification, it should be recognized by those of ordinary skill in the art that practically any size guardrail support post may be weakened as described above. The size, weight and configuration of the support post are just a few factors to be considered to determine the appropriate location of cutouts, to allow yielding along the weak axis while maintaining sufficient strength along the strong axis to redirect impacting vehicles. Further, although it may be desirable for at least a portion of the support posts in the guardrail safety system **100** to include weakened support posts such as support posts **500** and **600** of FIGS. **5A-5C**, support posts may also include conventional, unmodified support posts or other structural members suitable for supporting a guardrail beam. FIGS. **7A-7C** illustrate such an unmodified support post. Support post **700** does not include cutouts **508** and may comprise standard line posts such as unmodified **W6x8.5** posts or any other support post of an appropriate size, weight and configuration.

Although certain of the support posts may be configured to release the guardrail beam element upon vehicular impact, it may be desirable for a terminal support post to remain coupled to guardrail beam even after an end-on or re-directive impact. FIGS. **8A** and **8B** illustrate an example embodiment of a terminal support post **800** that may be used in conjunction with guardrail system **100** of FIG. **1**. Referring to FIG. **1**, terminal support post **800** is the first terminal support post at the upstream end of terminal section **108**. FIG. **8A** is a side view of terminal support post **800**, and FIG. **8B** is a front view of the same terminal support post **800**.

In particular embodiments, terminal support post **800** is releasably coupled to guardrail beam **102** such that guardrail beam **102** and provides positive anchorage of guardrail beam **102** to react to tensile loads on guardrail beam **102** to redirect

a vehicle impacting laterally along the length of guardrail beam **102**. Various components are used to effect the coupling of guardrail beam **102** to terminal support post **800** such that guardrail beam **102** remains coupled to terminal support post **800** when guardrail system **100** is struck by an impacting vehicle in an end-on or re-directive type impact. As a result, guardrail beam element remains supported in tension even after such an impact. However, when guardrail system **100** is struck by an impacting vehicle in the reverse direction, the tensile coupling of guardrail beam **102** will be released from terminal support post **800** to prevent vehicle instability and excessive vehicular deceleration.

In the illustrated embodiment, terminal support post **800** includes a structural member **802** of an I-beam configuration. Structural member **802** includes a pair of flanges **804** interconnected by a central web **806**. In a currently preferred embodiment, the beam member **802** comprises a W 6×15 steel post member. A pair of rectangular side plates **808** are affixed opposite sides of structural member **802**. Preferably, side plates **808** are secured by welding to each of flanges **804**.

A connector assembly is used to couple structural member **802** to the guardrail beam member. The connector assembly is configured such that the coupling of the structural member and the terminal portion of the guardrail beam is maintained during an end-on or re-directive impact by a vehicle. However, the connector assembly is configured to release the coupling during a reverse-direction impact. In a particular embodiment, the connector assembly comprises a plurality of stacked rectangular plates that are aligned to receive the terminal portion of the guardrail beam. For example, the connector assembly may include a stack of three plates: a flange plate **810**, a keeper plate **816**, and a washer plate **824**.

A flange plate **810** is secured between side plates **808**. Flange plate **810** is preferably a unitarily formed piece that is secured by welding to structural member **802** and each side plate **808**. Flange plate **810**, as best shown in FIG. 9A, includes a rectangular plate with a V-shaped cut-out **812** at the center of an upper edge **813** of flange plate **810**. In the illustrated embodiment, flange plate **810** has a length of approximately 5 inches and a width of approximately 6 inches. The thickness of flange plate **810**, as best shown in FIG. 8B, may be approximately 1 inch.

V-shaped slot **812** is centered along the horizontal width of flange plate **810** and has a vertical length of approximately 1 inch and a horizontal width of approximately 1¾ inches. The rounded bottom **814** of V-shaped slot **812** has a diameter of approximately 1¼ inches. However, the described and depicted dimensions of flange plate **810** are provided for example purposes only. Although the depicted dimensions may be appropriate where structural member **802** includes a W 6×15 steel post member, the dimensions of flange plate **810** may vary and may depend on size and dimensions of structural member **802**.

Returning to FIG. 8B, a keeper plate **816** is disposed adjacent to flange plate **810**. Similar to flange plate **810**, keeper plate **816** is preferably a unitarily formed piece. As best shown in FIG. 9B, keeper plate **816** includes a rectangular plate with a circular shaped opening **818** proximate an upper edge **820** of keeper plate **816**. In the illustrated embodiment, keeper plate **816** has a vertical length of approximately 3½ inches and a horizontal width of approximately 5⅝ inches. Opening **818** is centered along the horizontal width of keeper plate **816** and has a center that is approximately ⅞ inch from upper edge **820** of keeper plate **816**. U-shaped opening **818** may have a diameter of approximately 1¼ inches. However, the described and depicted dimensions of keeper plate **816** are provided for example purposes only. Although the depicted

dimensions may be appropriate where structural member **802** includes a W 6×15 steel post member, the dimensions of keeper plate **816** may vary and may depend on size and dimensions of structural member **802** and flange plate **810**.

Returning to FIG. 8B, a washer plate **824** is disposed adjacent to keeper plate **816**. Similar to flange plate **810** and keeper plate **816**, washer plate **824** is preferably a unitarily formed piece. As best shown in FIG. 9C, washer plate **824** includes a rectangular plate with a U-shaped slot **826** at the center of the upper edge **828** of washer plate **824**. In the illustrated embodiment, washer plate **824** has a vertical length of approximately 4⅛ inches and a horizontal width of approximately 5½ inches. The thickness of washer plate **824**, as best shown in FIG. 8B, may be approximately ½ inch.

U-shaped slot **826** is centered along the horizontal width of washer plate **824** and has a vertical length of approximately 1¼ inches and a horizontal width of approximately 1⅝ inches. The rounded bottom slot **826** has a diameter of approximately 1¼ inches. However, the described and depicted dimensions of washer plate **824** are provided for example purposes only. Although the depicted dimensions may be appropriate where structural member **802** includes a W 6×15 steel post member, the dimensions of washer plate **824** may vary and may depend on size and dimensions of structural member **802**.

Each of flange plate **810**, keeper plate **816**, and washer plate **824** include a pair of boltholes **830**. In the illustrated embodiments, boltholes **830** are approximately ⅜ inches in diameter. When assembled together, a bolthole **830** of each of flange plate **810**, keeper plate **816**, and washer plate **824** are in general alignment with one another. A pair of threaded bolts **832** may be secured through boltholes **830** to secure flange plate **810**, keeper plate **816**, and washer plate **824** together. A washer **834** may be threaded onto the end of each of the threaded bolts **832** to hold the plates relative to each other.

As described above, the purpose of terminal support post **800** is to secure guardrail beam **102** in tension. FIGS. 10A and 10B illustrate an exemplary tensile connection of a guardrail beam **1000** to a terminal support post such as terminal support post **800** depicted in FIGS. 8A and 8B. Specifically, a compressed slotted guardrail beam **1000** similar to those described above with regard to FIGS. 1, 2, and 4A-4B is coupled to a connection plate **1002**.

In the illustrated embodiment, connection plate **1002** includes a pair of boltholes **1004**, which may be aligned with a pair of similar boltholes (not shown) in the terminal end of the compressed slotted guardrail beam **1000**. A pair of threaded bolts **1006** may be threaded through boltholes **1004** and similarly sized boltholes of guardrail beam **1000** (not shown) that are aligned with boltholes **1004**. A threaded nut **1008** may secure each connection of bolts **1006** through connection plate **1002** and guardrail beam **1000**. In a particular embodiment, the boltholes **1004** and boltholes in guardrail beam **1000** may have a diameter on the order of approximately ⅞ inch. In such an embodiment, threaded bolts **1006** may include 2½×¾" GR. 5 bolts. However, it is recognized that these sizes are provided as examples only. Any appropriate size of boltholes and bolts may be used to secure guardrail beam **1000** to connection plate **1002**.

Connection plate **1002** is coupled to a threaded rod **1010**. In a particular embodiment, threaded rod **1010** may be welded to connection plate **1002**. As best shown in FIG. 8B, threaded rod **1010** is threaded through V-shaped cutout **814** of flange plate **810**, circular opening **818** of keeper plate **816**, and U-shaped cutout **826** of washer plate **824**. A nut **836** is threaded on the end of threaded rod **101** to secure guardrail beam **1000** in tension to terminal support post **800**.

15

The presence of nut **836** prevents withdrawal of cable **1010** from the openings formed by V-shaped cutout **814** of flange plate **810** and U-shaped cutout **826** of washer plate **824**. Since the opening of keeper plate **816** includes an enclosed circular opening **818** rather than an open cutout in the edge of the keeper plate **816**, keeper plate **816** ensures that threaded rod **1010** is properly in place. Keeper plate **816** also adds strength to the tensile connection of threaded rod **1010** to terminal post **800**. Washer plate **824**, which functions as a washer between bolt **834** and keeper plate **816**, also adds strength to the connection.

During an end-on or redirective impact to a guardrail system incorporating the above-described features, the assembly described in FIGS. **8A-8B**, **9A-9C**, and **10A-10B** enables the tensile connection of guardrail beam **1010** to terminal support post **800** to remain intact. Because the guardrail beam **1010** remains in tension, guardrail beam **1010** is able to redirect the impacting vehicle. Column buckling of the system may be eliminated and an eccentric impacting vehicle may remain in the system longer during deceleration.

In contrast, when a vehicle impacts the guardrail system in a reverse direction, the tensile connection of guardrail beam **1010** may be released. For example, the reverse-direction impact may cause the upper edge **820** of keeper plate **816** directly above circular opening **818** to be sheared. Threaded rod **1010** is then freed from the openings formed by V-shaped cutout **812**, U-shaped cutout **826**, and circular opening **818**. Because the tensile connection in guardrail beam **1000** is released, guardrail beam **1000** may be controllably collapsed to prevent vehicle instability or excessive deceleration.

To further aid in the release of the tensile connection during a reverse-direction impact, a modified strut may be used to couple the terminal support post to the first adjacent support post. Such a strut is indicated as reference numeral **140** in FIG. **2** and is illustrated in more detail in FIGS. **11A** and **11B**. In the illustrated embodiment, strut **140** includes a longitudinal beam member **1112** that has been modified to include a strut plate **1114**. Longitudinal beam member **1112** may include have any appropriate cross-sectional shape. The length of longitudinal beam member **1112** is appropriate for coupling terminal support post **106** and the next adjacent support post **104**. In a particular embodiment, longitudinal beam member **1112** may include a C-channel member having a width on the order of approximately 6 inches and a depth on the order of approximately 2 inches.

As best shown in FIG. **11B**, strut plate **1114** is preferably a unitarily formed piece that is secured by welding to longitudinal beam member **1112**. Strut plate **1114** includes a rectangular plate with a U-shaped cut-out **1116** at the center of the upper edge **1118** of strut plate **1114**. In the illustrated embodiment, strut plate **1114** has a horizontal dimension of approximately 10 inches and a vertical dimension of approximately 8 inches. The thickness of strut plate **1114** may be approximately $\frac{1}{4}$ inch. U-shaped slot **1116** is centered along the vertical dimension of strut plate **1114** and has a vertical dimension of approximately $1\frac{1}{2}$ inch and a horizontal dimension of approximately $5\frac{1}{2}$ inches. The rounded bottom **1120** of U-shaped slot **1116** has a diameter of approximately $1\frac{1}{2}$ inches. However, the described and depicted dimensions of strut plate **1114** are provided for example purposes only. The dimensions of strut plate **1114** and longitudinal beam member **1112** may vary.

When a vehicle impacts the guardrail system in a reverse direction, strut **1112** and strut plate **1114** may facilitate the release of the tensile connection between the guardrail beam and the terminal support post. Strut plate **1114** is positioned proximate the outlet end of flattening portion **112**. Strut plate

16

1114 operates as a ramp to facilitate the lifting of the threaded rod coupled to the guardrail beam from the V-shaped cutout **814** of flange plate **810**, circular opening **818** of keeper plate **816**, and U-shaped cutout **826** of washer plate **824**. Because the tensile connection in guardrail beam **1000** is released, strut **1112** and strut plate **1114** prevent instability or excessive deceleration of the impacting vehicle.

As described above, FIGS. **10A** and **10B** illustrate an exemplary tensile connection of a guardrail beam to a threaded rod. FIG. **12** illustrates an alternative embodiment of a tensile connection that may be used to couple a guardrail beam to a terminal post. In the illustrated embodiment, a slotted guardrail beam **1200** may be modified similar to guardrail beam **200** of FIG. **4A**. Slotted guardrail beam **1200** is modified at the terminal end **1202** and is coupled to a cable rod **1204**. In a particular embodiment, slotted guardrail beam **1200** may be coupled to a pair of cable rods **1204**.

Cable rods **1204** may traverse through a flattening portion **1206**. Flattening portion **1206** may be similar to flattening portion **110** of FIGS. **1-3**. Accordingly, at least a portion of cable rods **1204** may traverse the length of flattening portion **1206** and exit an outlet **1206** at an upstream end of flattening portion **1206**. After exiting the outlet **1206**, cable rods **1204** may be secured to a terminal post **106** at ground level using a mechanism similar to that described above with regard to FIGS. **8A-8B**, **9A-9C**, and **10A-10B**.

Technical advantages of particular embodiments of the present invention include a guardrail end treatment that dissipates impact energy through the compression of a W-beam guardrail element. Specifically, the guardrail end treatment may dissipate impact energy of a vehicle colliding with an end of a guardrail by flattening a portion of the guardrail required for deceleration of the impacting vehicle. Another advantage may be that the end treatment forces the W-beam guardrail element through a flattening structure that squeezes the guardrail into a relatively flat plate. In contrast to prior systems, the W-beam guardrail element may be flattened vertically rather than horizontally.

Still another advantage may be that a tensile and resistive coupling may be provided for connecting an end of the W-beam guardrail element to a terminal support post. The components of the system that provide the tensile connection of the guardrail beam to the terminal support post may enable the guardrail beam to remain secured after an end-on or re-redirective impact. Thus, the system may remain in tension during both types of impacts. Still another advantage may be that the tension is released when the system is impacted in the reverse direction near the terminal end, however. The releasing of tension in the guardrail element for reverse direction impacts prevents vehicle instability and excessive deceleration.

Although the present invention has been described by several embodiments, various changes and modifications may be suggested to one skilled in the art. It is intended that the present invention encompass such changes and modifications as fall within the scope of the present appended claims. For example, the features described above may be used independently and/or in combination with each other or other design modifications.

What is claimed is:

1. A terminal portion of a guardrail safety system comprising:
 - a terminal portion of a guardrail beam comprising a downstream end and upstream end, the terminal portion of the guardrail beam sloping from a height appropriate for

17

- redirecting an errant vehicle to a height proximate the surface of the ground at an upstream end of the terminal portion;
- a plurality of support posts installed adjacent a roadway in spaced apart relation to one another, the plurality of support posts coupled to the terminal portion of the guardrail beam; and
- a terminal support post installed adjacent the roadway at an upstream end of the terminal portion of the guardrail beam, the terminal support post coupled to an upstream end of the terminal portion of the guardrail beam by a resistive, tensile coupling that selectively maintains tension in the terminal portion of the guardrail beam, the resistive, tensile coupling maintained between the terminal support post and the guardrail beam during an end-on or re-directive impact by a vehicle, the resistive, tensile coupling released between the terminal support post and the guardrail beam during a reverse-direction impact.
2. The terminal portion of claim 1, wherein the terminal portion of the guardrail beam is substantially parallel to the roadway.
3. The terminal portion of claim 1, wherein the terminal portion of the guardrail beam is flared away from the roadway at an upstream end of the guardrail beam.
4. The terminal portion of claim 3, wherein the flare is substantially parabolic.
5. The terminal portion of claim 3, wherein the flare is substantially linear.
6. The terminal portion of claim 1, wherein the guardrail beam member comprises a longitudinally corrugated W-beam having upper and lower peaks and a valley between the peaks.
7. The terminal portion of claim 6, wherein the terminal portion of the guardrail beam member is modified to include a slotted zone, the slotted zone comprising a set of three slots extending longitudinally in each of the upper and lower peaks and the valley between the peaks, the slotted zone increasing the ability of the terminal portion of the guardrail beam member to be flattened.
8. The terminal portion of claim 7, wherein the upstream end of the guardrail beam member is flattened into four vertically stacked plates.
9. The terminal portion of claim 1, wherein the upstream end of the guardrail beam member is coupled to a threaded rod, the threaded rod cooperating with the resistive, tensile coupling to maintain tension in the terminal portion of the guardrail beam upon the end-on or redirective impact by the vehicle.
10. The terminal portion of claim 1, further comprising an impact head coupled to the first support disposed downstream from the terminal support post, the impact head operable to be horizontally displaced in the downstream direction during an end-on collision for the dissipation of impact energy.
11. The terminal portion of claim 1, wherein at least one of the plurality of support posts comprise a modified support post, the modified support post comprising:
- a lower portion for installing below grade adjacent the roadway;
 - a mid portion that lies substantially adjacent the grade, the mid portion including a weakened section operable to weaken the support post about a first axis without substantially changing the behavior of the support post about a second axis that is generally perpendicular to the first axis; and
 - an upper portion releasably coupled to the terminal portion of the guardrail beam.

18

12. A terminal portion of a guardrail safety system comprising:
- a terminal portion of a guardrail beam;
 - a terminal support post coupled to an upstream end of the terminal portion of the guardrail beam, the terminal support post comprising:
 - a structural member having a longitudinal axis, the structural member for installing below grade adjacent the roadway;
 - a connector assembly selectively coupling the terminal portion of the guardrail beam to the structural member at an acute angle relative to the longitudinal axis of the structural member, the connector assembly comprising an opening through which the upstream end of the terminal portion of the guardrail beam is disposed;
- and wherein the selective coupling of the structural member and the terminal portion of the guardrail beam is maintained during an end-on or re-directive impact by a vehicle and is released during a reverse-direction impact.
13. The terminal portion of claim 12, wherein the structural member comprises a pair of flanges interconnected by a central web.
14. The terminal portion of claim 13, wherein the plurality of plates comprise:
- a first plate having a V-shaped cut-out;
 - a second plate having a circular shaped opening; and
 - a third plate having a U-shaped cut-out; and
- wherein the V-shaped cut-out, the circular opening, and the U-shaped cut-out are aligned with one another when the first, second, and third plates are stacked adjacent to one another.
15. The terminal portion of claim 12, the connector assembly comprises a plurality of plates stacked adjacent to one another and disposed at an acute angle relative to the longitudinal axis of the structural member, at least one of the plurality of plates affixed to an end of the structural member, each of the plurality of plates comprising an opening.
16. The terminal portion, of claim 12, further comprising a plurality of support posts installed adjacent a roadway in spaced apart relation to one another, the plurality of support posts coupled to the terminal portion of the guardrail beam.
17. The terminal portion of claim 16, wherein the terminal portion of the guardrail beam is substantially parallel to the roadway.
18. The terminal portion of claim 16, wherein the terminal portion of the guardrail beam is flared away from the roadway at an upstream end of the guardrail beam.
19. The terminal portion of claim 18, wherein the flare is substantially parabolic.
20. The terminal portion of claim 18, wherein the flare is substantially linear.
21. The terminal portion of claim 12, wherein the guardrail beam member comprises a longitudinally corrugated W-beam having upper and lower peaks and a valley between the peaks.
22. The terminal portion of claim 21, wherein the terminal portion of the guardrail beam member is modified to include a slotted zone, the slotted zone comprising a set of three slots extending longitudinally in each of the upper and lower peaks and the valley between the peaks, the slotted zone increasing the ability of the terminal portion of the guardrail beam member to be flattened.
23. The terminal portion of claim 21, wherein the upstream end of the guardrail beam member is flattened into four vertically stacked plates.

24. The terminal portion of claim 12, wherein the upstream end of the guardrail beam member is coupled to a threaded rod, the threaded rod secured through the opening in the connector assembly.

25. A terminal portion of a guardrail safety system comprising:

a terminal portion of a guardrail beam comprising a downstream end and an upstream end, the terminal portion of the guardrail beam sloping from a first height appropriate for redirecting an errant vehicle to a second height proximate the surface of the ground at an upstream end of the terminal portion;

a plurality of support posts installed adjacent a roadway in spaced apart relation to one another, the plurality of support posts coupled to the terminal portion of the guardrail beam; and

a terminal support post coupled to the upstream end of the terminal portion of the guardrail beam, the terminal support post comprising:

a structural member having a longitudinal axis, the structural member for installing below grade adjacent the roadway;

a connector assembly selectively coupling the terminal portion of the guardrail beam to the structural member at an acute angle relative to the longitudinal axis of the structural member; and

wherein the selective coupling of the structural member and the terminal portion of the guardrail beam is maintained during an end-on or re-directive impact by a vehicle and is released during a reverse-direction impact.

26. The terminal portion of claim 25, wherein the terminal portion of the guardrail beam is substantially parallel to the roadway.

27. The terminal portion of claim 25, wherein the terminal portion of the guardrail beam is flared away from the roadway at an upstream end of the guardrail beam.

28. The terminal portion of claim 27, wherein the flare is substantially parabolic.

29. The terminal portion of claim 27, wherein the flare is substantially linear.

30. The terminal portion of claim 25, wherein the guardrail beam member comprises a longitudinally corrugated W-beam having upper and lower peaks and a valley between the peaks.

31. The terminal portion of claim 30, wherein the terminal portion of the guardrail beam member is modified to include a slotted zone, the slotted zone comprising a set of three slots extending longitudinally in each of the upper and lower peaks and the valley between the peaks, the slotted zone increasing the ability of the terminal portion of the guardrail beam member to be flattened.

32. The terminal portion of claim 30, wherein the upstream end of the guardrail beam member is flattened into four vertically stacked plates.

33. The terminal portion of claim 25, wherein the upstream end of the guardrail beam member is coupled to a threaded rod, the threaded rod cooperating with connector assembly to maintain tension in the terminal portion of the guardrail beam upon the end-on or redirective impact by the vehicle.

34. The terminal portion of claim 25, further comprising an impact head coupled to the first support disposed downstream from the terminal support post, the impact head operable to be horizontally displaced in the downstream direction during an end-on collision for the dissipation of impact energy.

35. The terminal portion of claim 25, wherein at least one of the plurality of support posts comprise a modified support post, the modified support post comprising:

a lower portion for installing below grade adjacent the roadway;

a mid portion that lies substantially adjacent the grade, the mid portion including a weakened section operable to weaken the support post about a first axis without substantially changing the behavior of the support post about a second axis that is generally perpendicular to the first axis; and

an upper portion releasably coupled to the terminal portion of the guardrail beam.

* * * * *