



US008232440B2

(12) **United States Patent**
Holtzapple et al.

(10) **Patent No.:** **US 8,232,440 B2**
(45) **Date of Patent:** **Jul. 31, 2012**

(54) **ALTERNATIVE PATHS TO ALCOHOLS AND HYDROCARBONS FROM BIOMASS**

FOREIGN PATENT DOCUMENTS

WO 2008141204 A2 11/2008

(75) Inventors: **Mark T. Holtzapple**, College Station, TX (US); **Cesar B. Granda**, College Station, TX (US); **Sebastian Taco-Vasquez**, Bryan, TX (US); **Michael Kyle Ross**, Bryan, TX (US); **Gary Luce**, Spring, TX (US); **John A. Spencer**, Cypress, TX (US); **Rae L. Spencer**, Cypress, TX (US)

OTHER PUBLICATIONS

International Preliminary Report on Patentability for PCT/US2009/066419 dated Jun. 6, 2011 (5 pages).

International Application No. PCT/US2009/066419 International Search Report dated Jul. 19, 2010, 9 pages.

Sen, B. et al. "Metal-Support Effects on Acetone Hydrogenation over Platinum Catalysts", *Journal of Catalysis* 113, 52-71 (1988).Aramendia, M. et al. "Catalytic Application of Zeolites in the Methanol Conversion to Hydrocarbons", *Chemistry Letters* 2002 (2 pgs.).van Druten et al. "Promotion Effects in the Hydrogenation of Propanal and Acetone Over Palladium", *React.Kint.Catal.Lett. vol. 68, No. 1* 15-23 (1999).Yurieva, T.M. "Mechanisms for activation of hydrogen and hydrogenation of acetone to isopropanol and of carbon oxides to methanol over copper-containing oxide catalysts", *Catalysis Today* 51 (1999) 457-467.Chang, Nan-Sheng et al., "Kinetic studies of ketone hydrogenation over Raney nickel catalyst", *Chemical Engineering Science* 55 (2000) 5721-5732.Comelli, R.A. et al., "Transformation of C1-C4 Alcohols into Hydrocarbons on a Amorphous Silica-Alumina Catalyst", *Applied Catalysis*, 36, 299-306 (1988).Minachev, Kh. M. et al., "Hydrogenation of Acetone on Cationic Forms of Zeolites", *Russian Chemical Bulletin*, vol. 23, 7 (1974) 1472-1475.Ardah, E. G. R. et al., "Distillation of Acetate of Lime", *Industrial and Engineering Chemistry*, vol. 16, No. 11 (Nov. 1924) 1133-1139.Hayashi, H. et al., "Conversion of Methanol into Hydrocarbons over Ammonium 12-Tungstophosphate", *Journal of Catalysis*, 83, 192-204 (1983).Setiadi, Suprpto et al., "Conversion of Acetone and Aromatic Chemicals with HZSM-5", *Journal of the Japan Institute of Energy*, 82, 926-932 (2003).Hutchings, Graham J. et al., "The Conversion of Methanol and Other O-Compounds to Hydrocarbons over Zeolite", *Journal of Catalysis* 147, 177-185 (1994).Takahara, Isco et al., "Dehydration of ethanol into ethylene over solid acid catalysts," *Catalysis letters* 105(3-4), 249-252 (2005).Mostafa, M. R. et al., "Conversion of ethanol and isopropanol on alumina, titania and alumina titania catalysts," *Material Letters* 12, 207-213 (1991).Le Van Mao, R. et al, "Ethylene from ethanol over zeolite catalysts," *Applied Catalysis* 34, 163-179 (1987).*Primary Examiner* — Brian J Davis(74) *Attorney, Agent, or Firm* — Timothy S. Westby; Porter Hedges LLP

(73) Assignees: **The Texas A&M University System**, College Station, TX (US); **Terrabon Mix-Alco, LLC**, Houston, TX (US)

(*) Notice: Subject to any disclaimer, the term of this patent is extended or adjusted under 35 U.S.C. 154(b) by 309 days.

(21) Appl. No.: **12/629,285**

(22) Filed: **Dec. 2, 2009**

(65) **Prior Publication Data**

US 2010/0185021 A1 Jul. 22, 2010

Related U.S. Application Data

(60) Provisional application No. 61/119,250, filed on Dec. 2, 2008.

(51) **Int. Cl.**
C01G 3/00 (2006.01)

(52) **U.S. Cl.** **585/240**

(58) **Field of Classification Search** None
See application file for complete search history.

(56) **References Cited**

U.S. PATENT DOCUMENTS

3,894,107	A	7/1975	Butter et al.
4,128,727	A	12/1978	Leupold et al.
4,293,499	A	10/1981	Hughes
4,421,939	A	12/1983	Kiff et al.
5,693,296	A	12/1997	Holtzapple et al.
5,865,898	A	2/1999	Holtzapple et al.
5,962,307	A	10/1999	Holtzapple et al.
5,973,193	A	10/1999	Crane et al.
5,986,133	A	11/1999	Holtzapple et al.
6,043,392	A	3/2000	Holtzapple et al.
6,262,313	B1	7/2001	Holtzapple et al.
6,395,926	B1	5/2002	Holtzapple et al.
6,927,048	B2	8/2005	Verser et al.
7,251,944	B2	8/2007	Holtzapple et al.
7,328,591	B2	2/2008	Holtzapple et al.
7,351,559	B2	4/2008	Verser et al.
8,153,850	B2	4/2012	Hall et al.
2003/0077771	A1	4/2003	Verser et al.
2006/0024801	A1	2/2006	Holtzapple et al.
2006/0188980	A1	8/2006	Holtzapple et al.
2007/0014895	A1	1/2007	Holtzapple et al.
2007/0299291	A1	12/2007	Koivusalmi
2008/0176301	A1	7/2008	Granda et al.
2008/0280338	A1	11/2008	Hall et al.
2009/0114591	A1	5/2009	Holtzapple et al.
2010/0185021	A1	7/2010	Ross et al.

(57) **ABSTRACT**

A method of producing alcohols, hydrocarbons, or both from biomass by converting biomass into a carboxylic acid, reacting the carboxylic acid with an olefin to produce an ester and hydrogenolyzing the ester to produce alcohol. A method of producing hydrocarbons from biomass by converting at least a portion of the biomass into a carboxylic acid, a ketone, or an ammonium carboxylate salt, reacting at least one of a portion of the carboxylic acid, a portion of the ketone, or a portion of the ammonium carboxylate salt in an oligomerization reactor as at least part of a process that produces an oligomerization product and separating hydrocarbons from the oligomerization product.

32 Claims, 37 Drawing Sheets

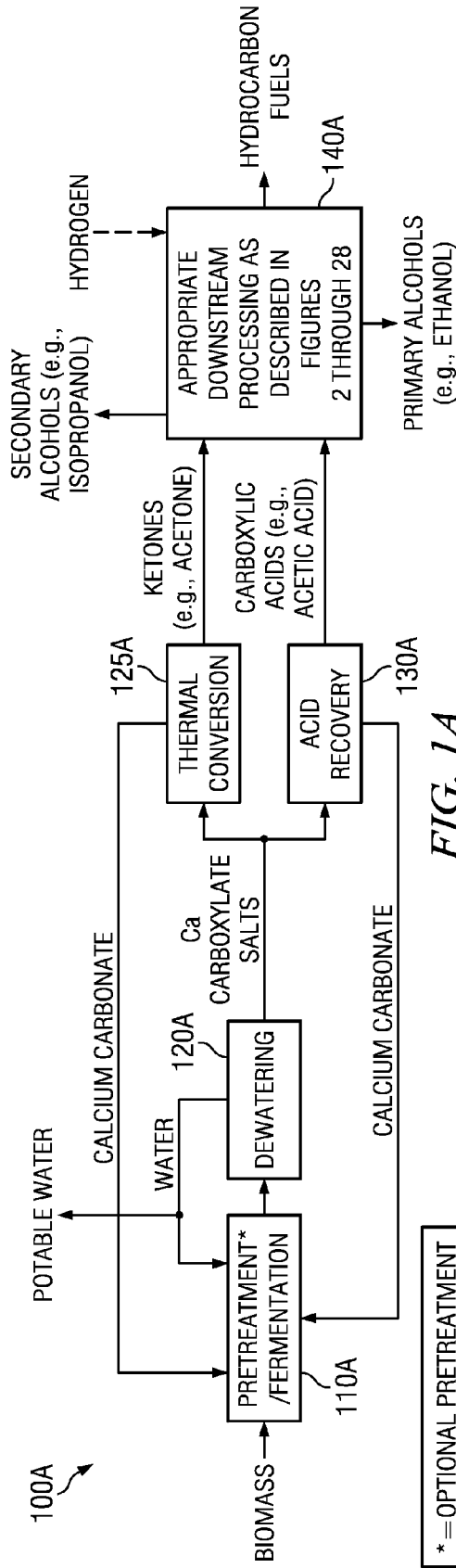

FIG. 1A

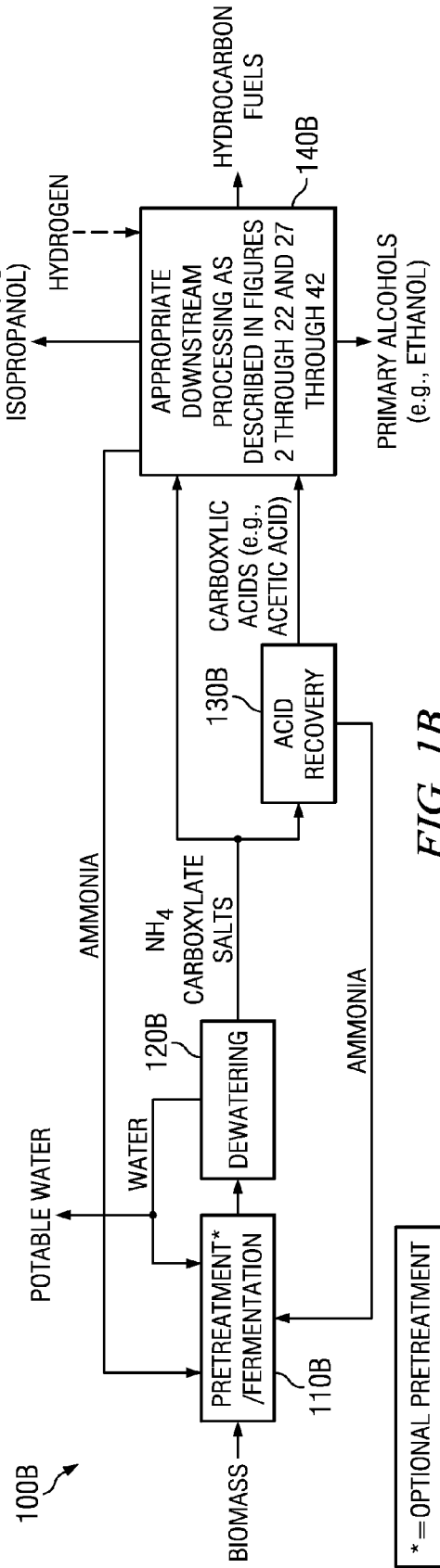

FIG. 1B

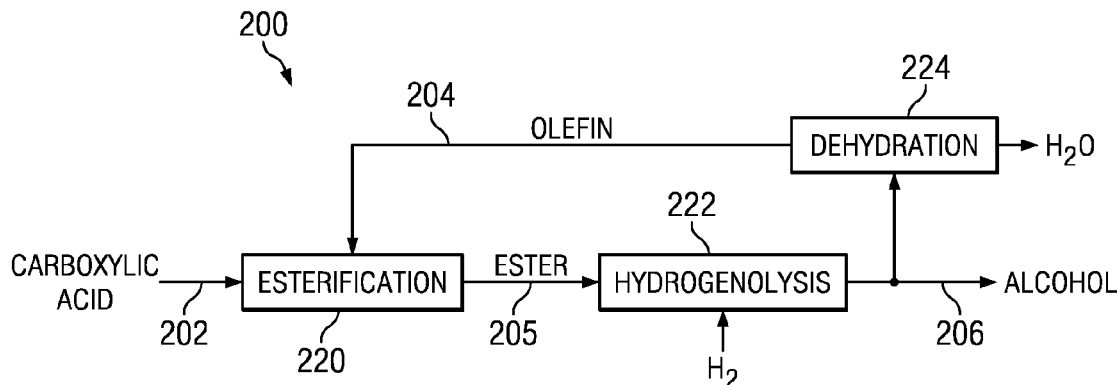

FIG. 2

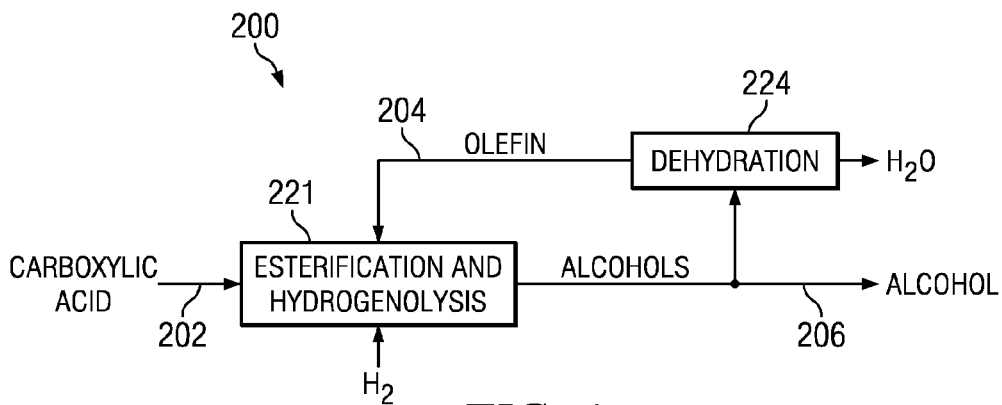

FIG. 4

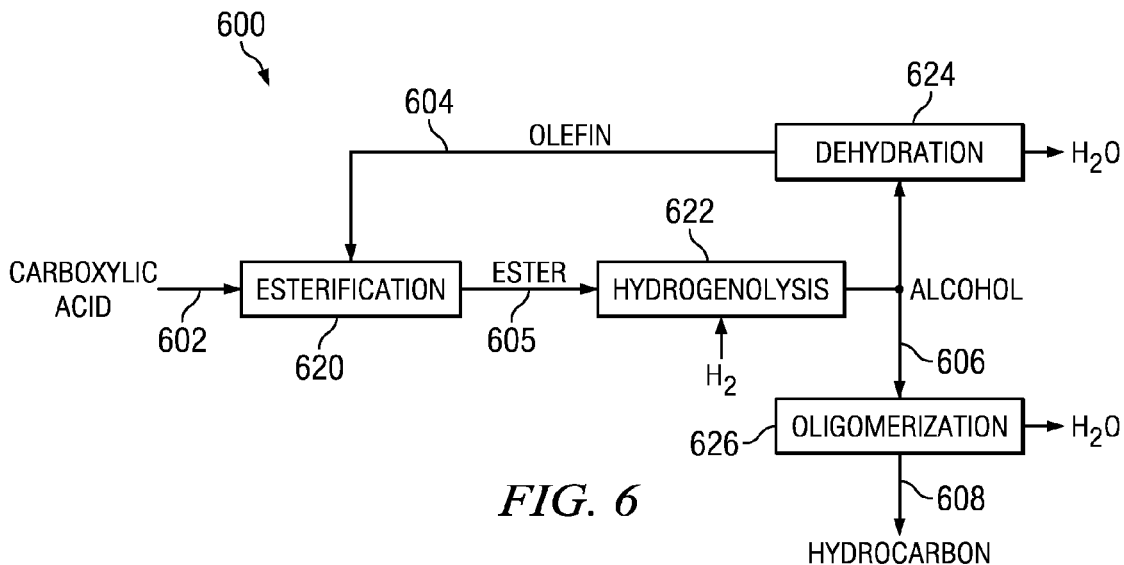

FIG. 6

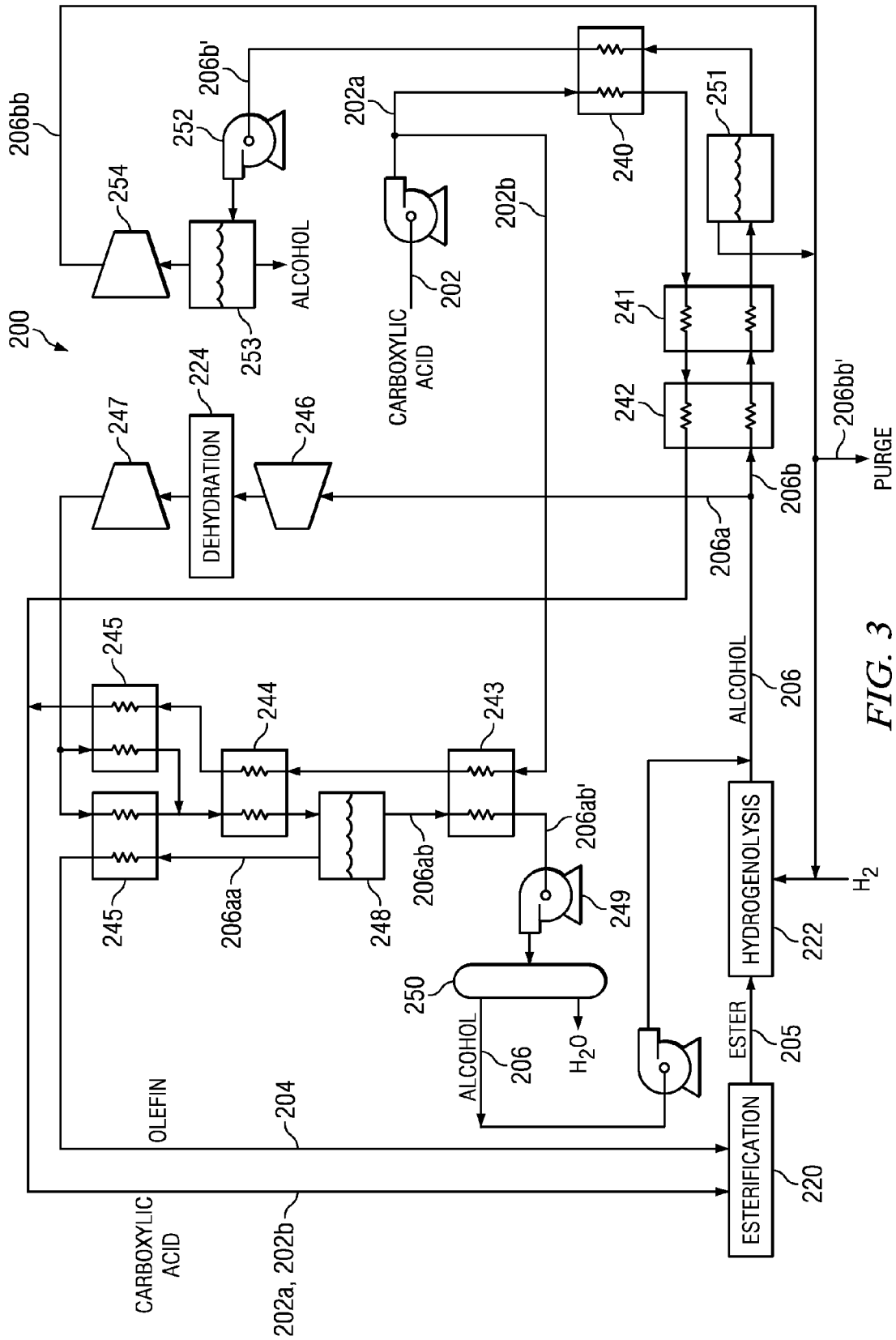

FIG. 3

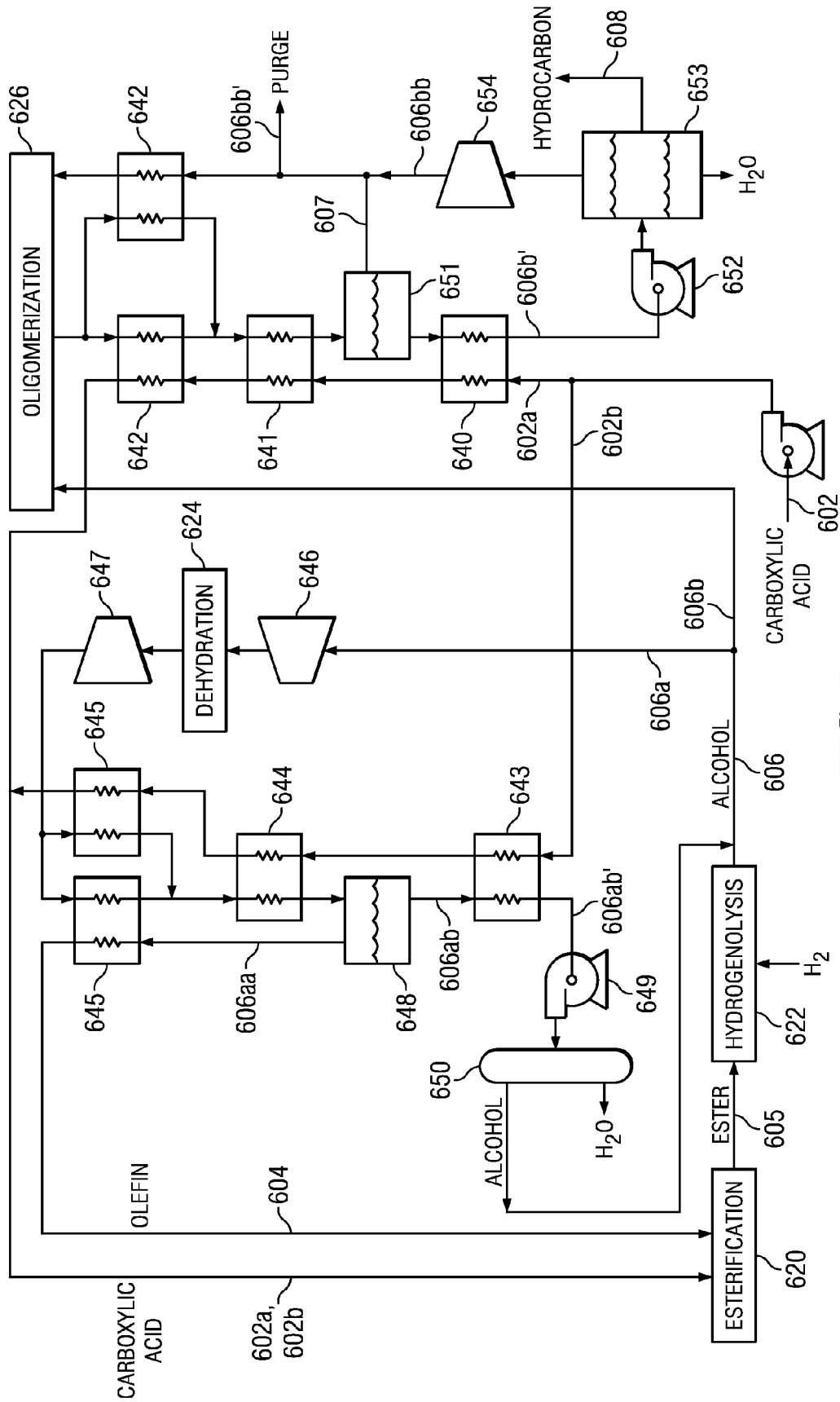
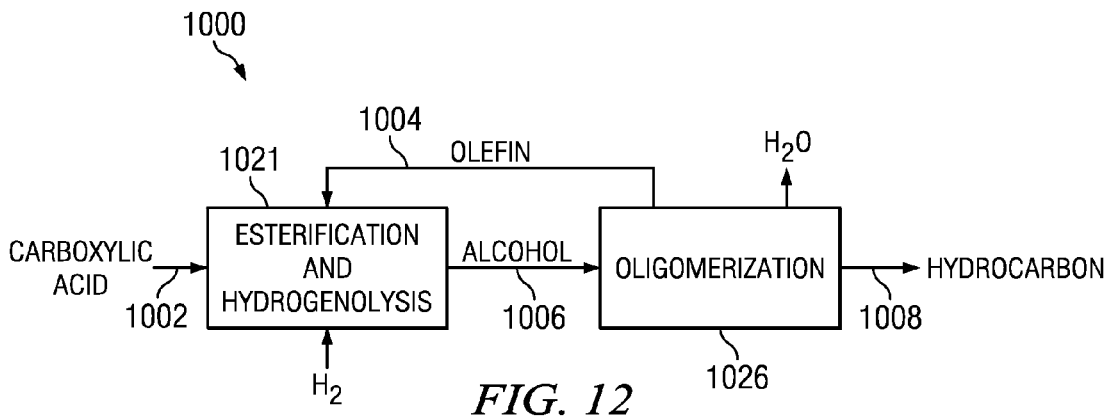
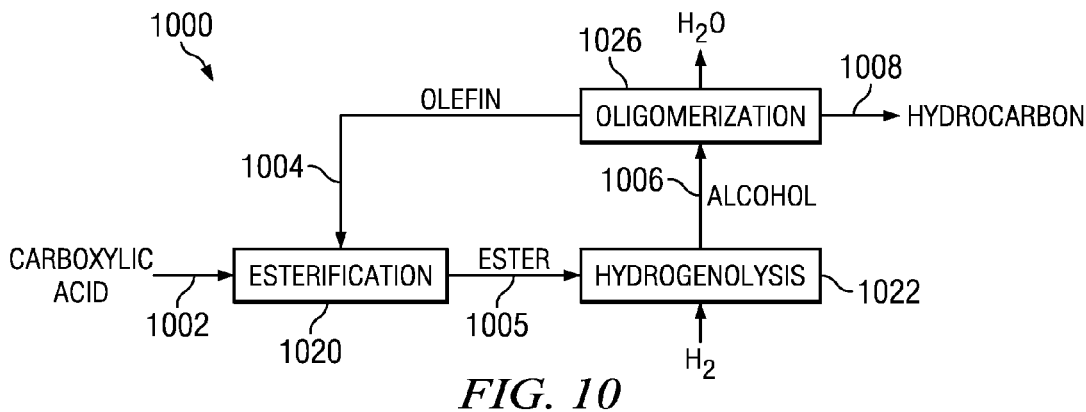
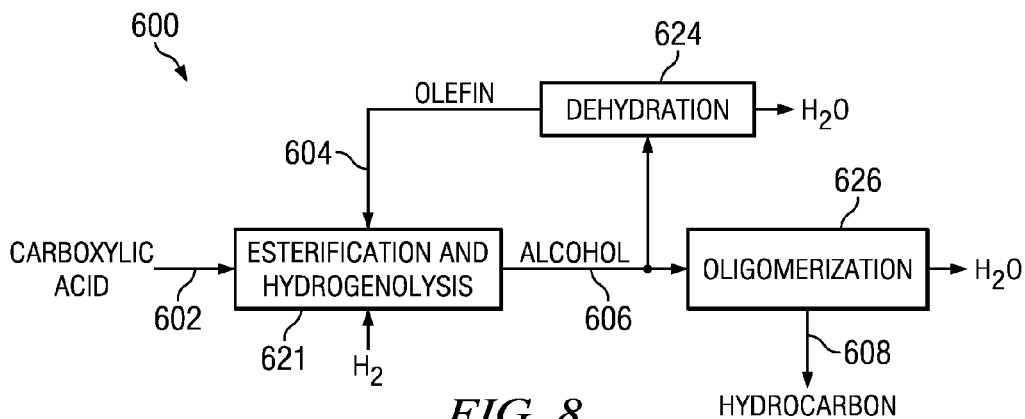

FIG. 7



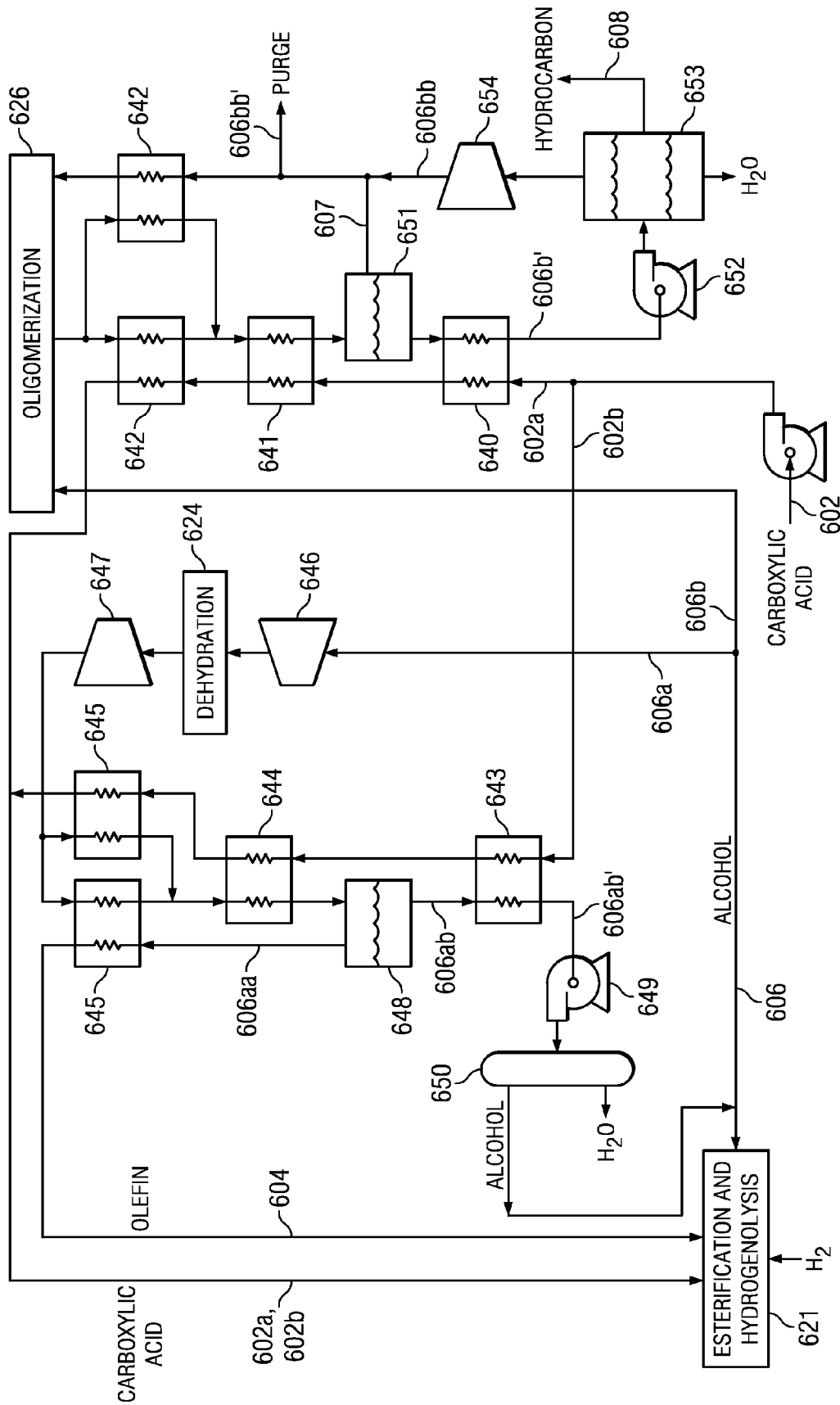

FIG. 9

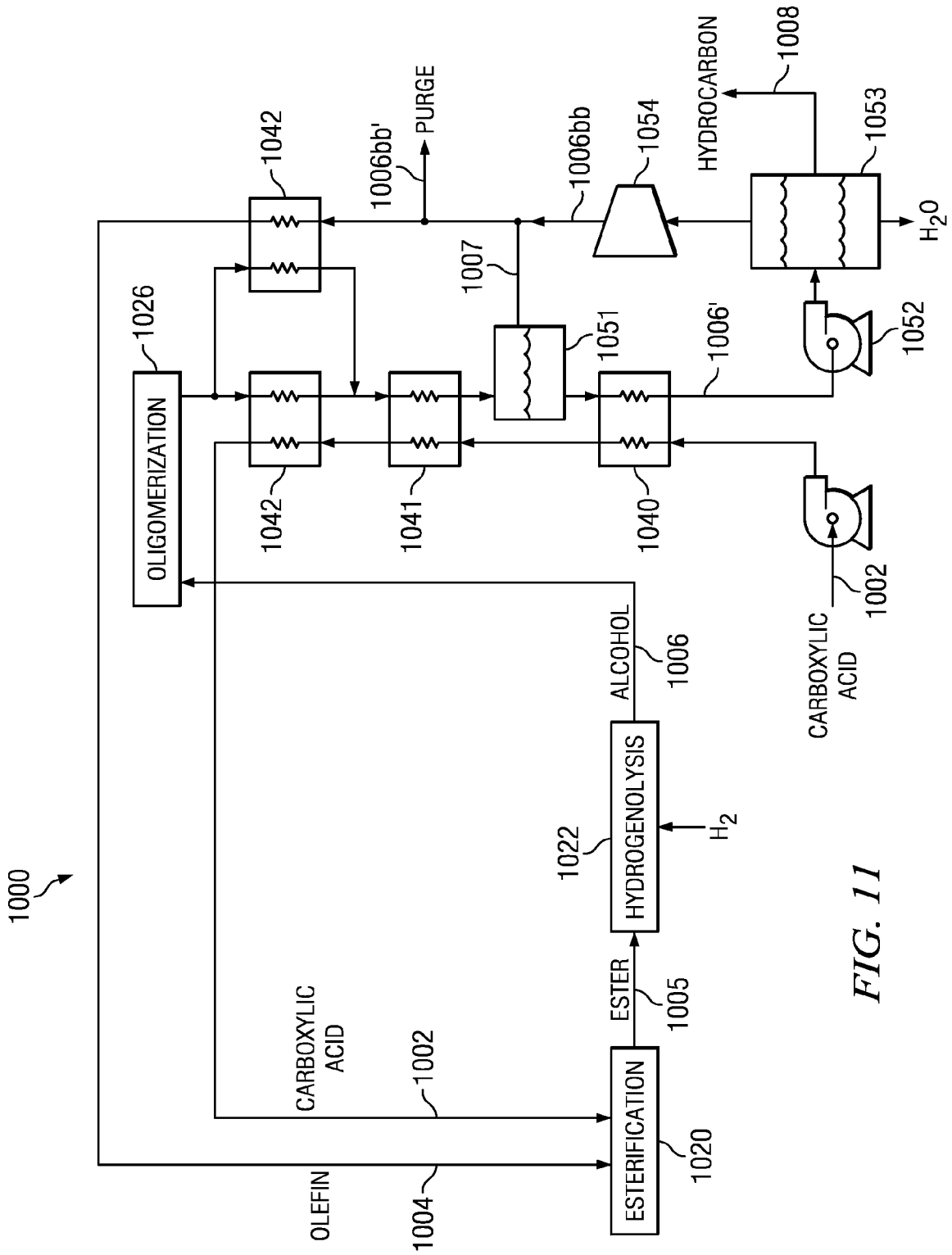

FIG. 11

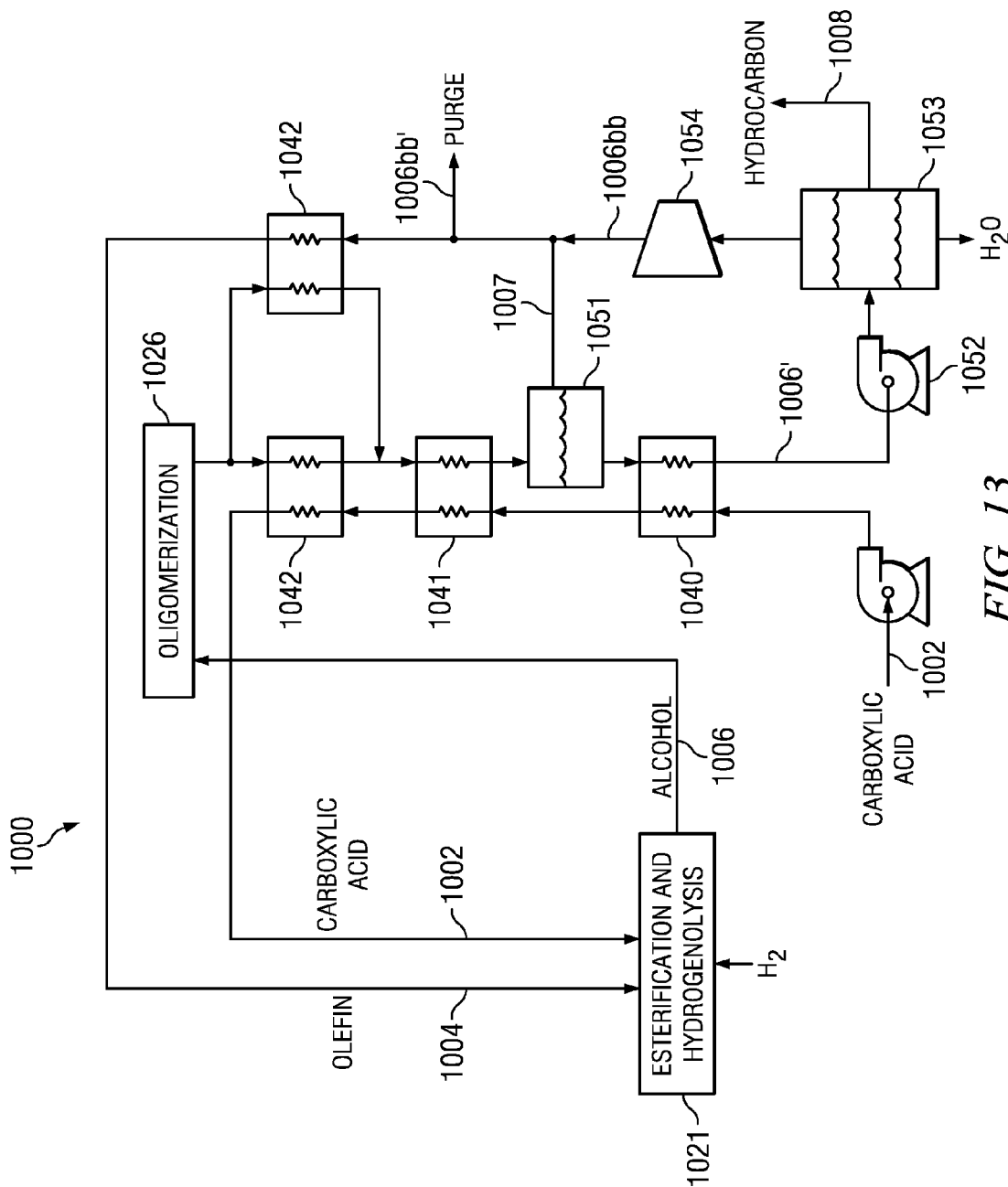

FIG. 13

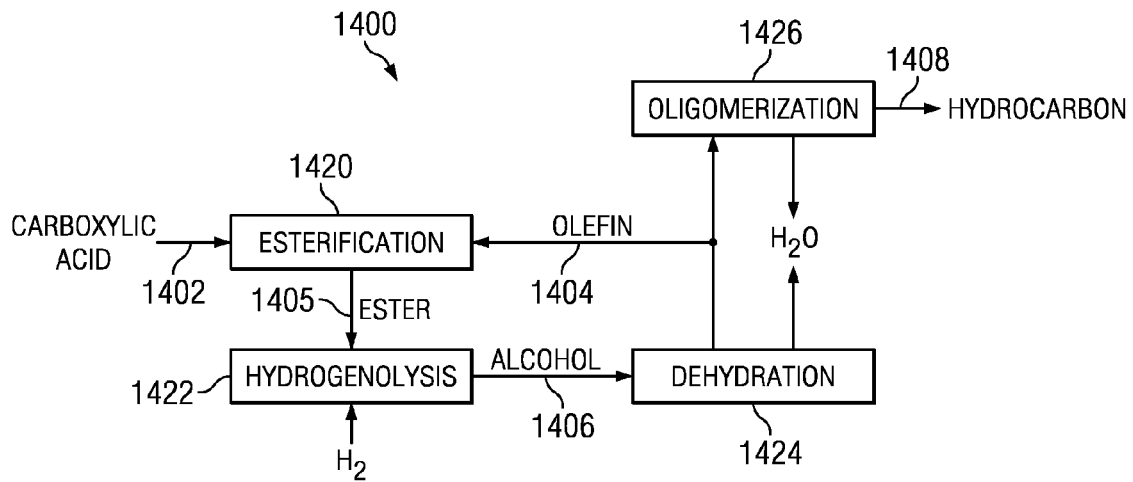

FIG. 14

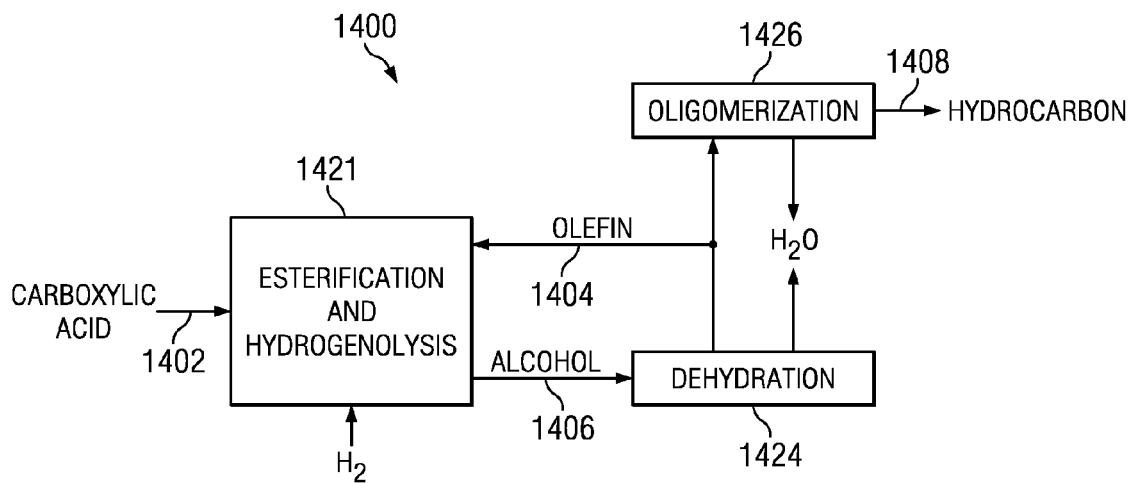

FIG. 16

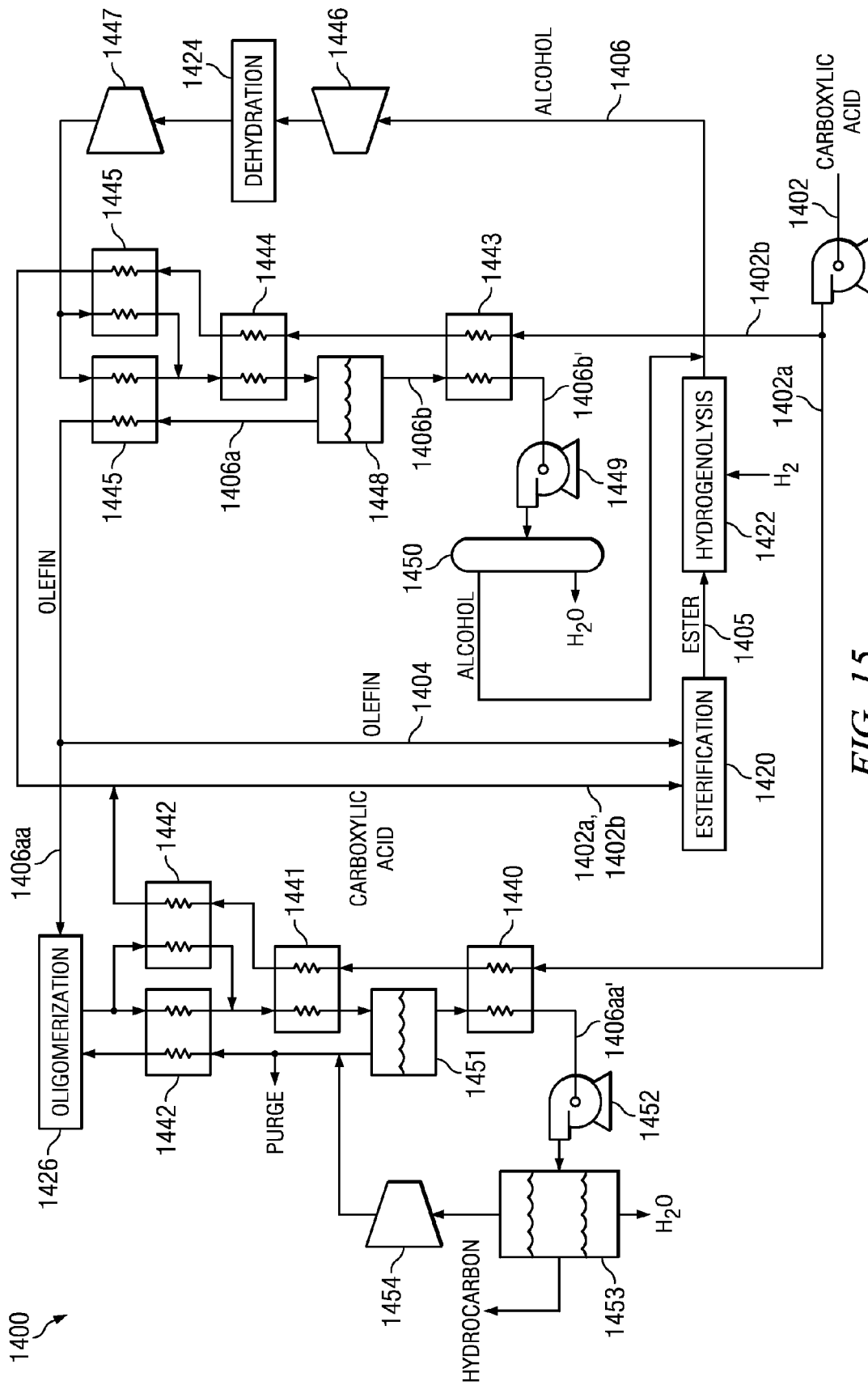

FIG. 15

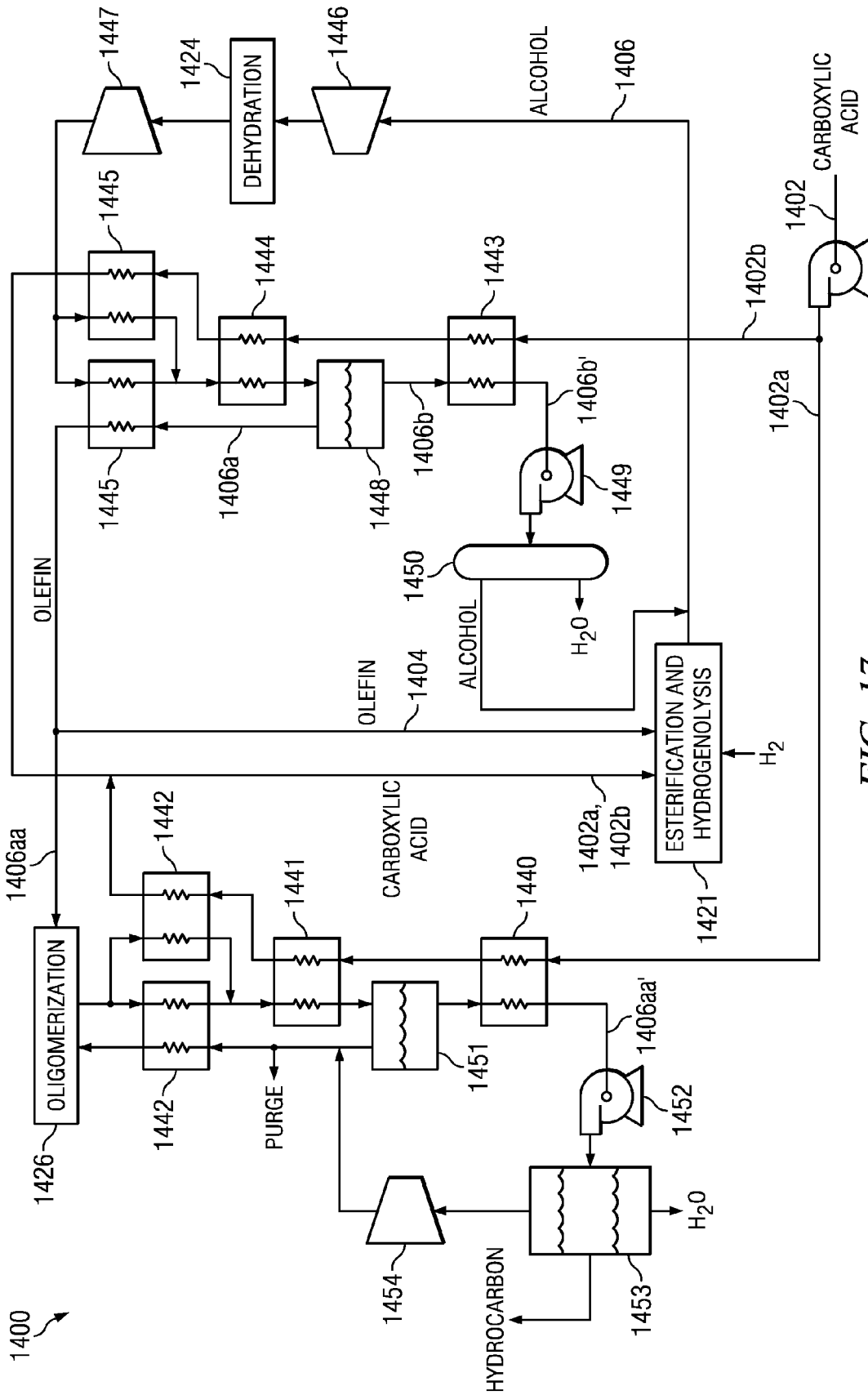

FIG. 17

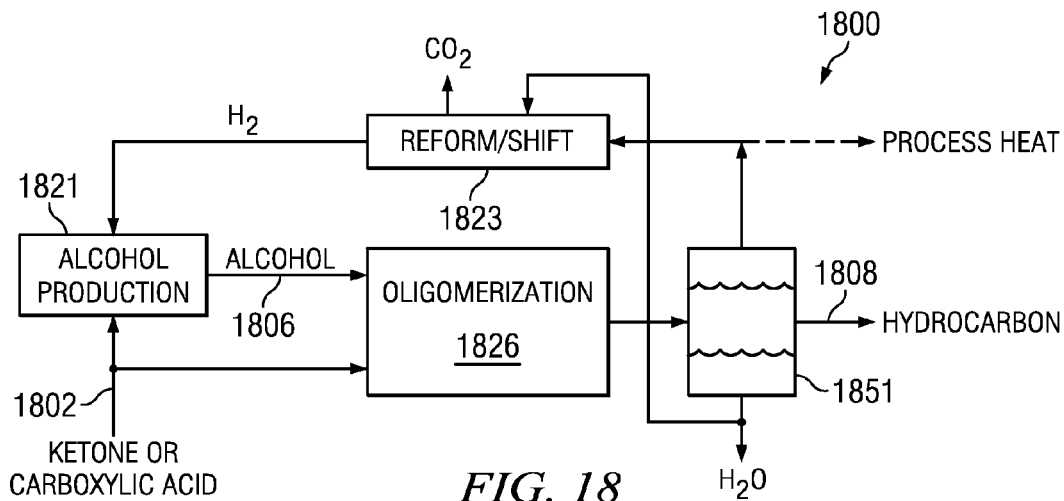

FIG. 18

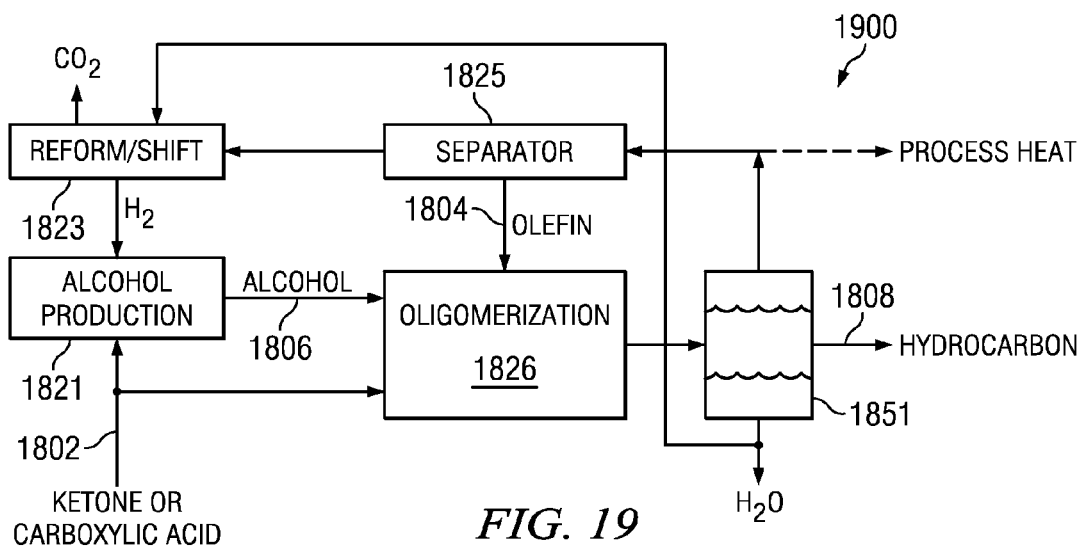

FIG. 19

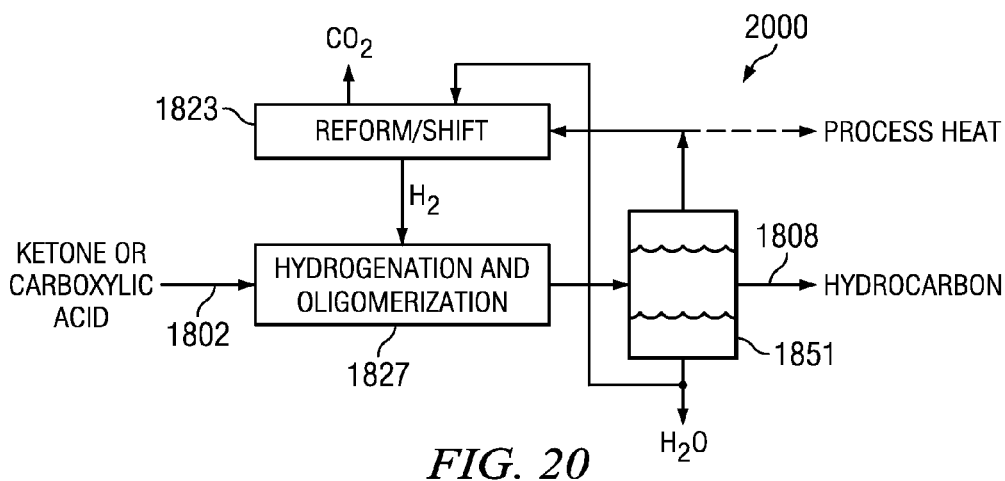
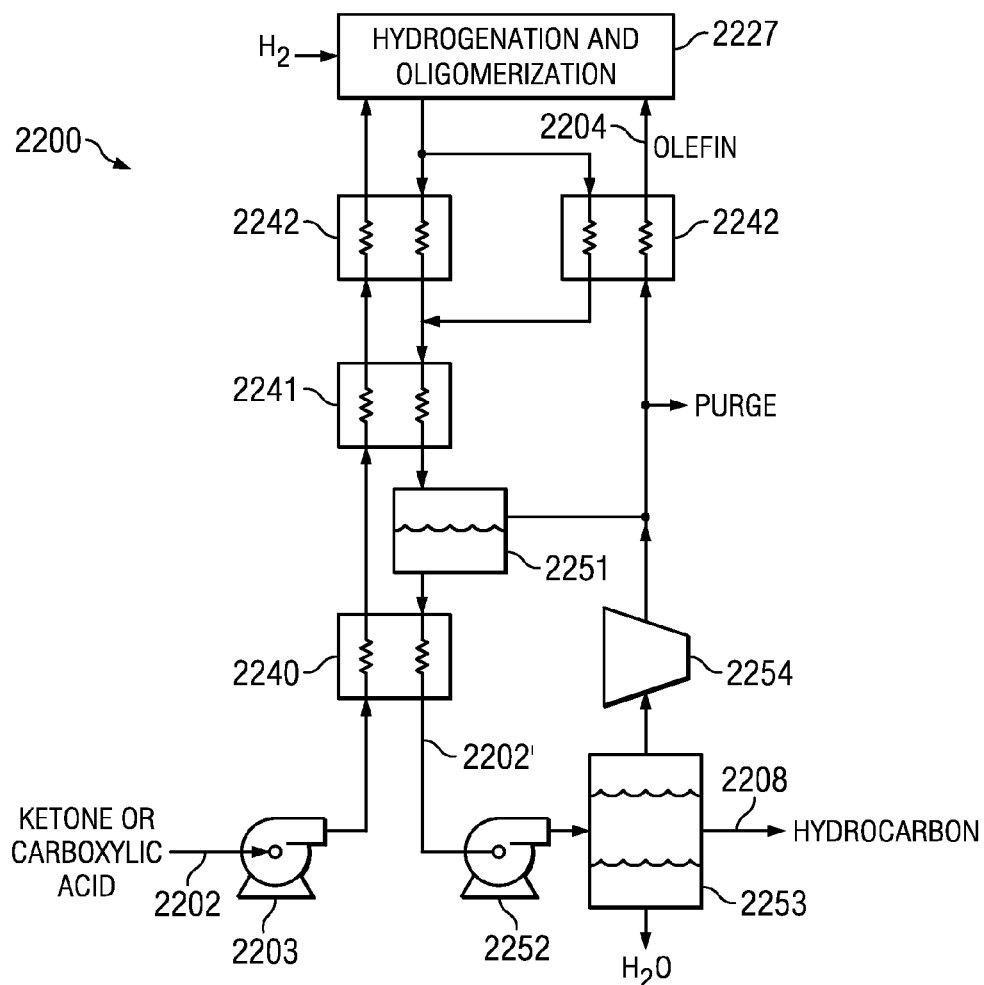
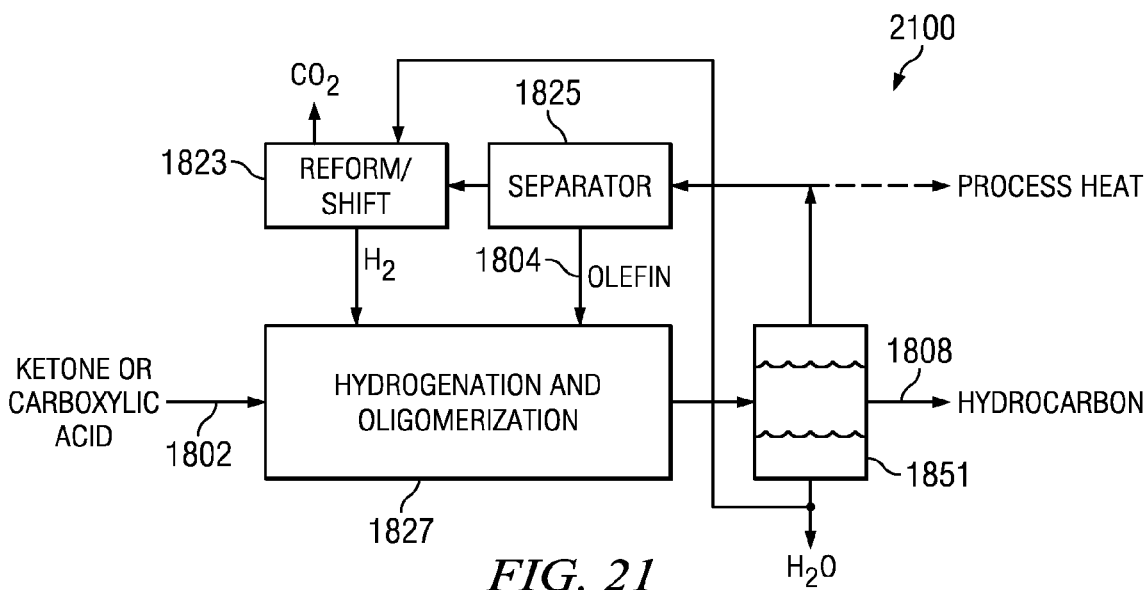

FIG. 20



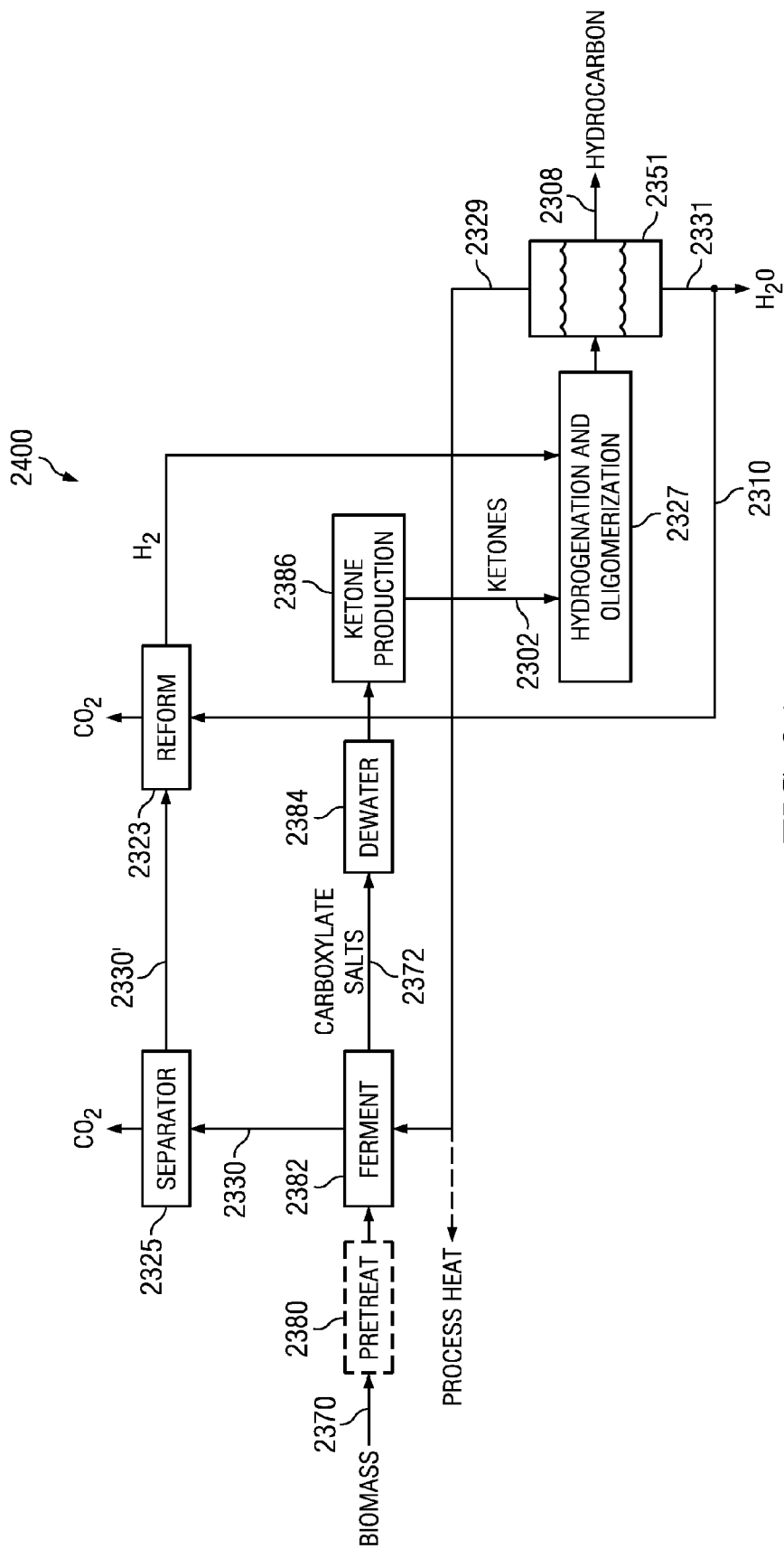

FIG. 24

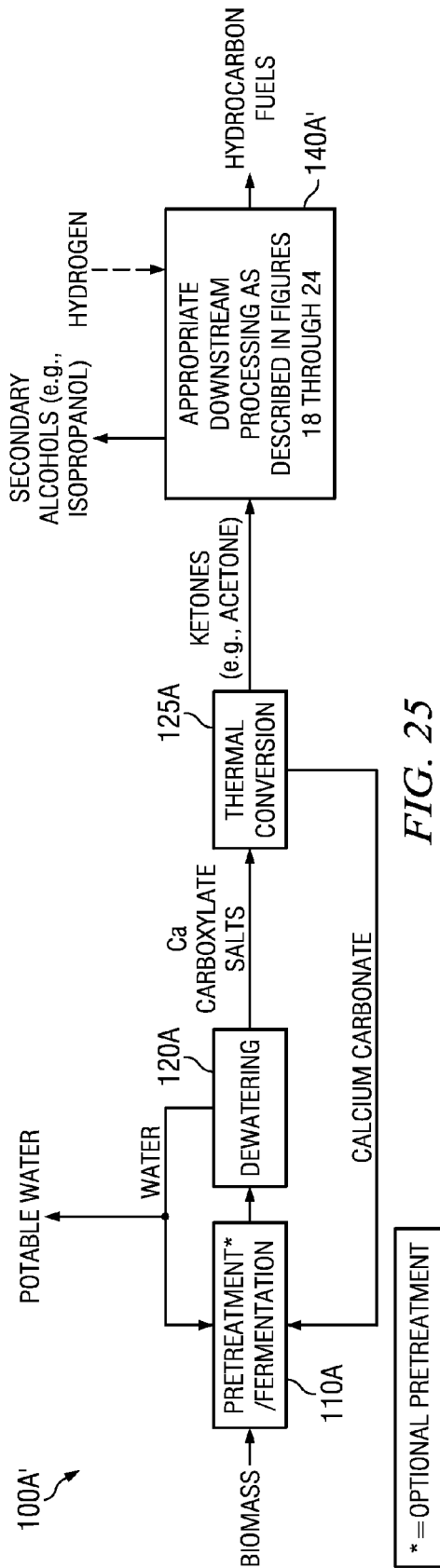

FIG. 25

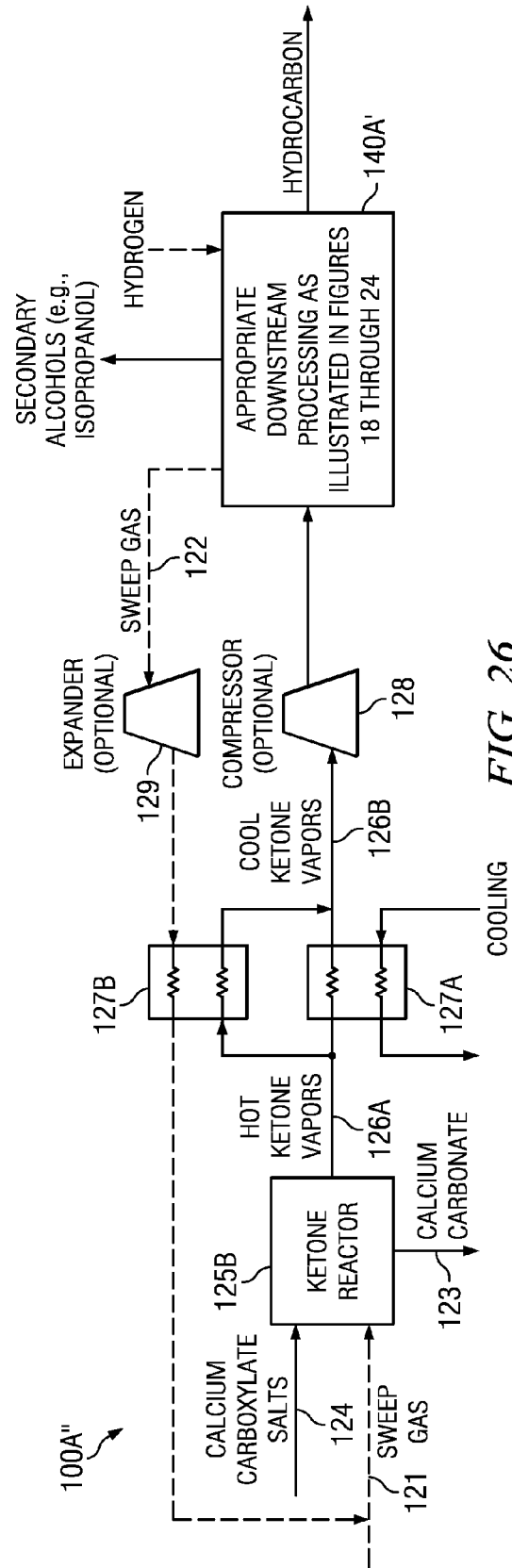

FIG. 26

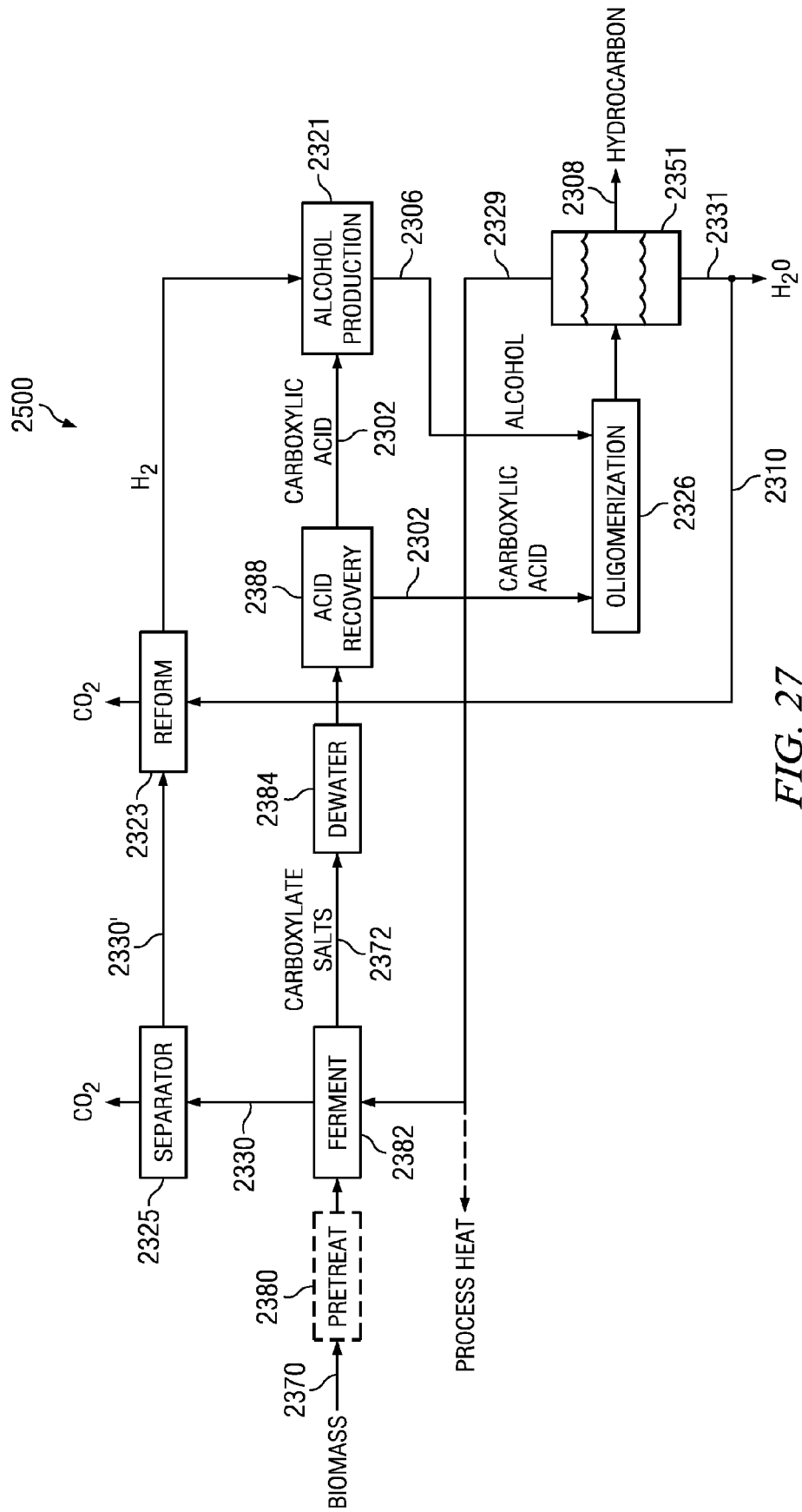

FIG. 27

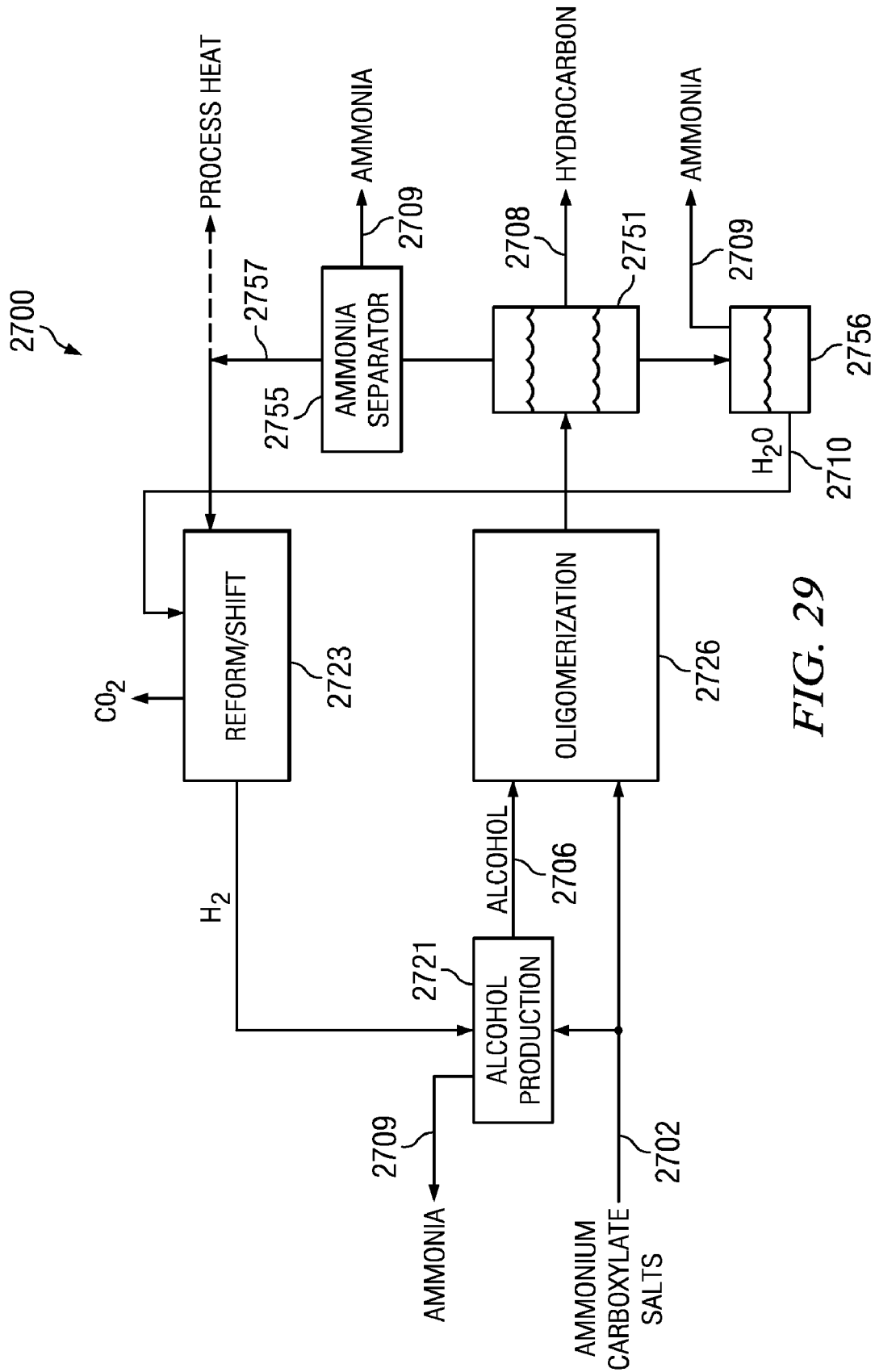

FIG. 29

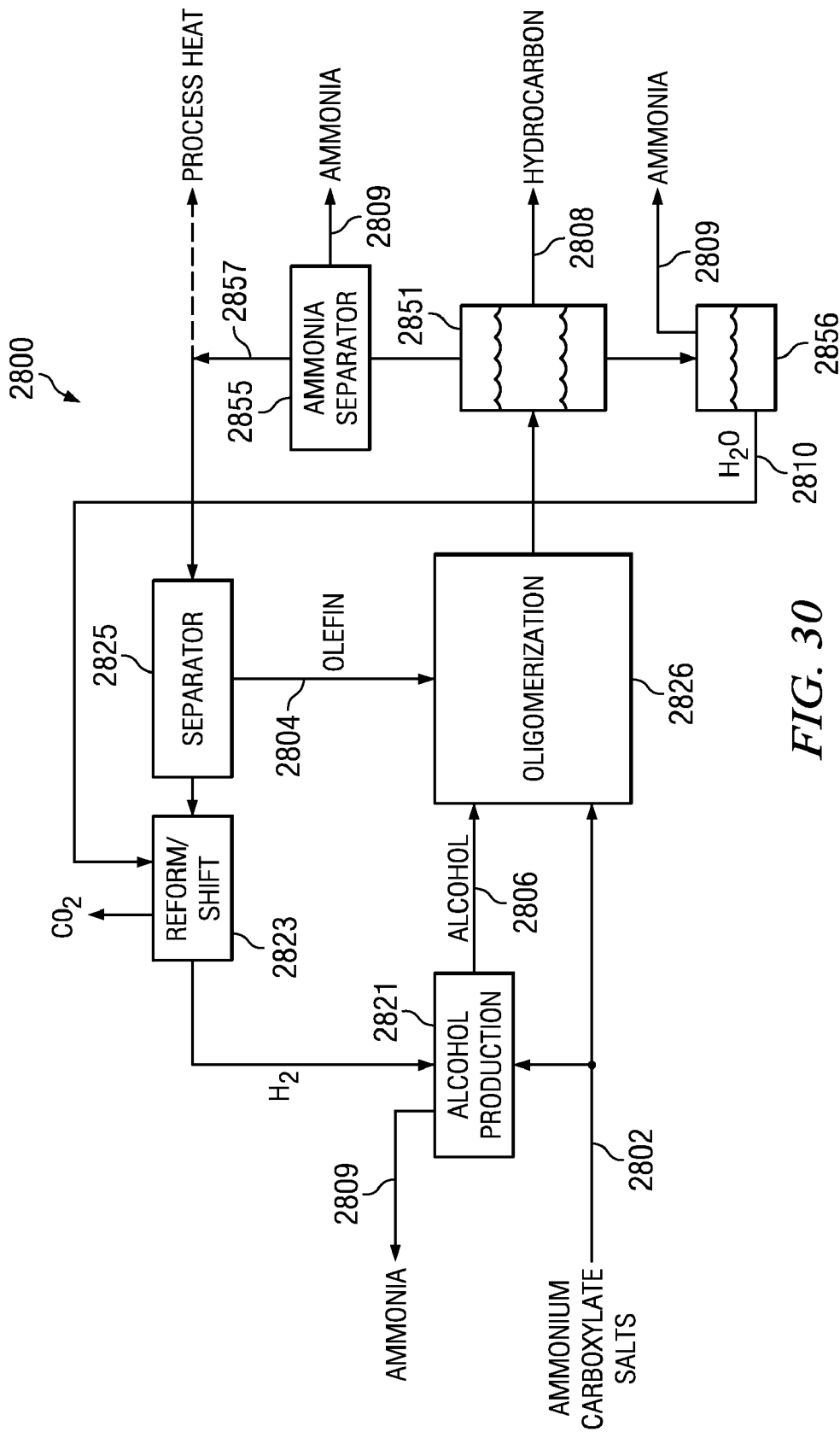

FIG. 30

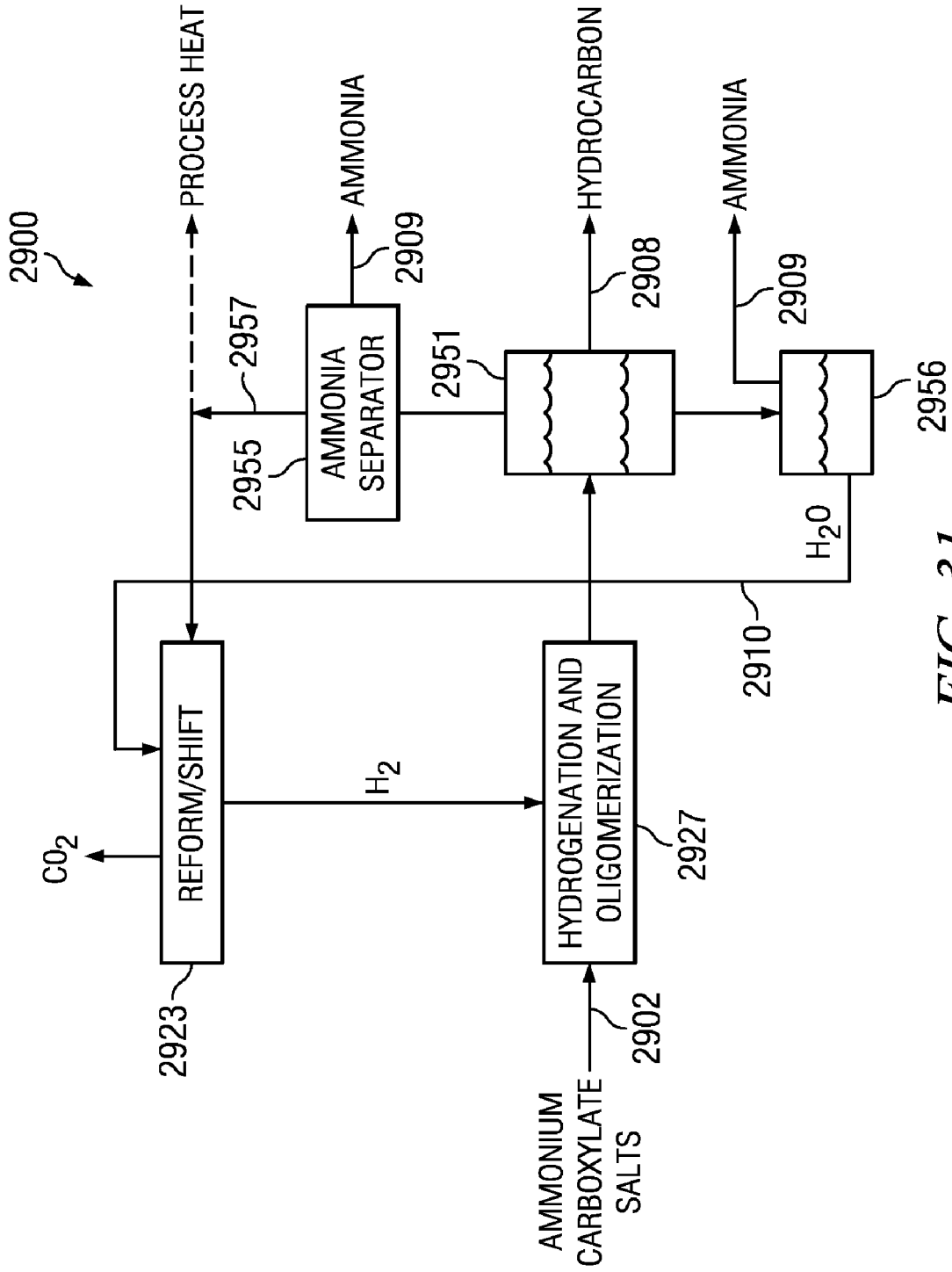

FIG. 31

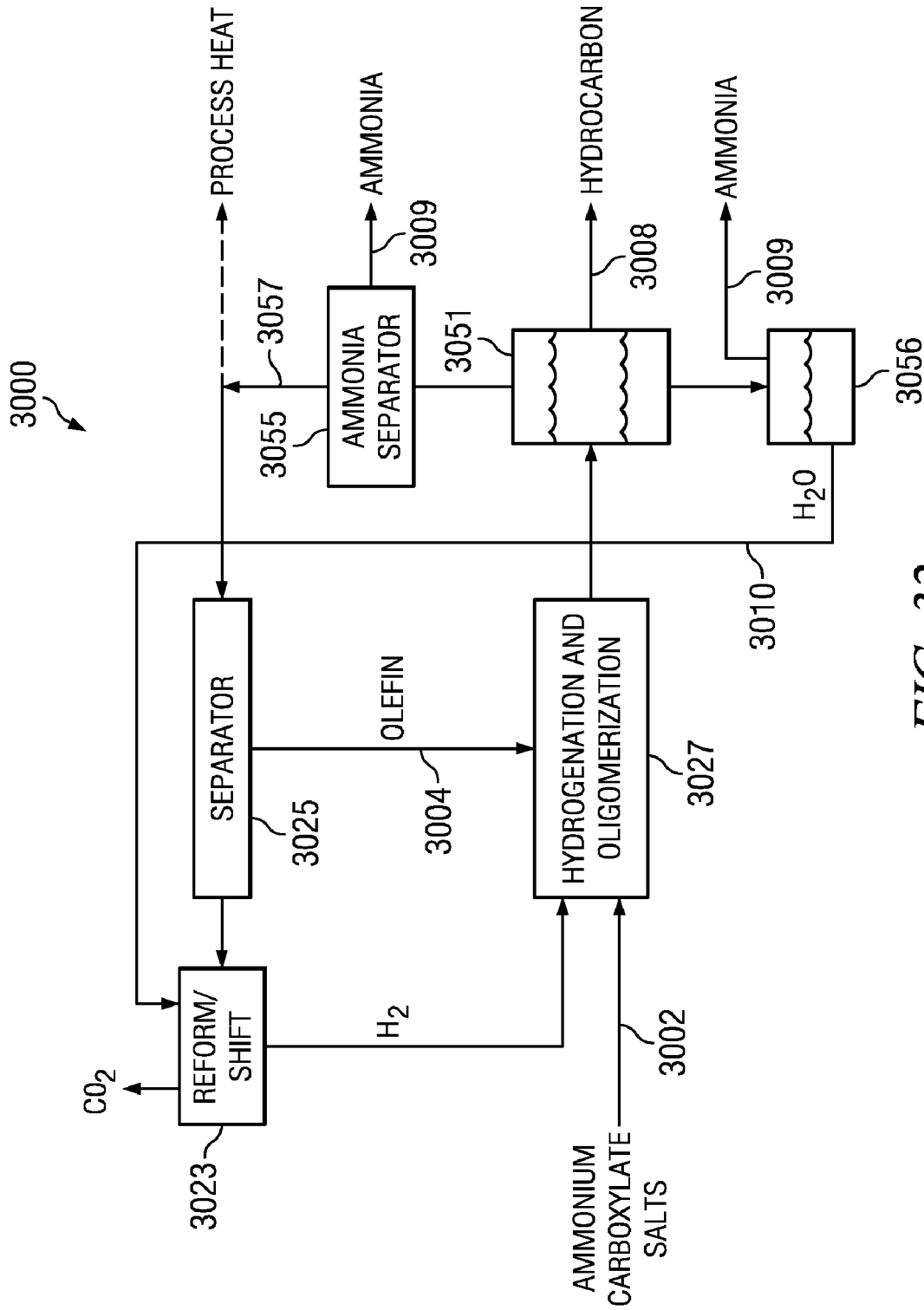

FIG. 32

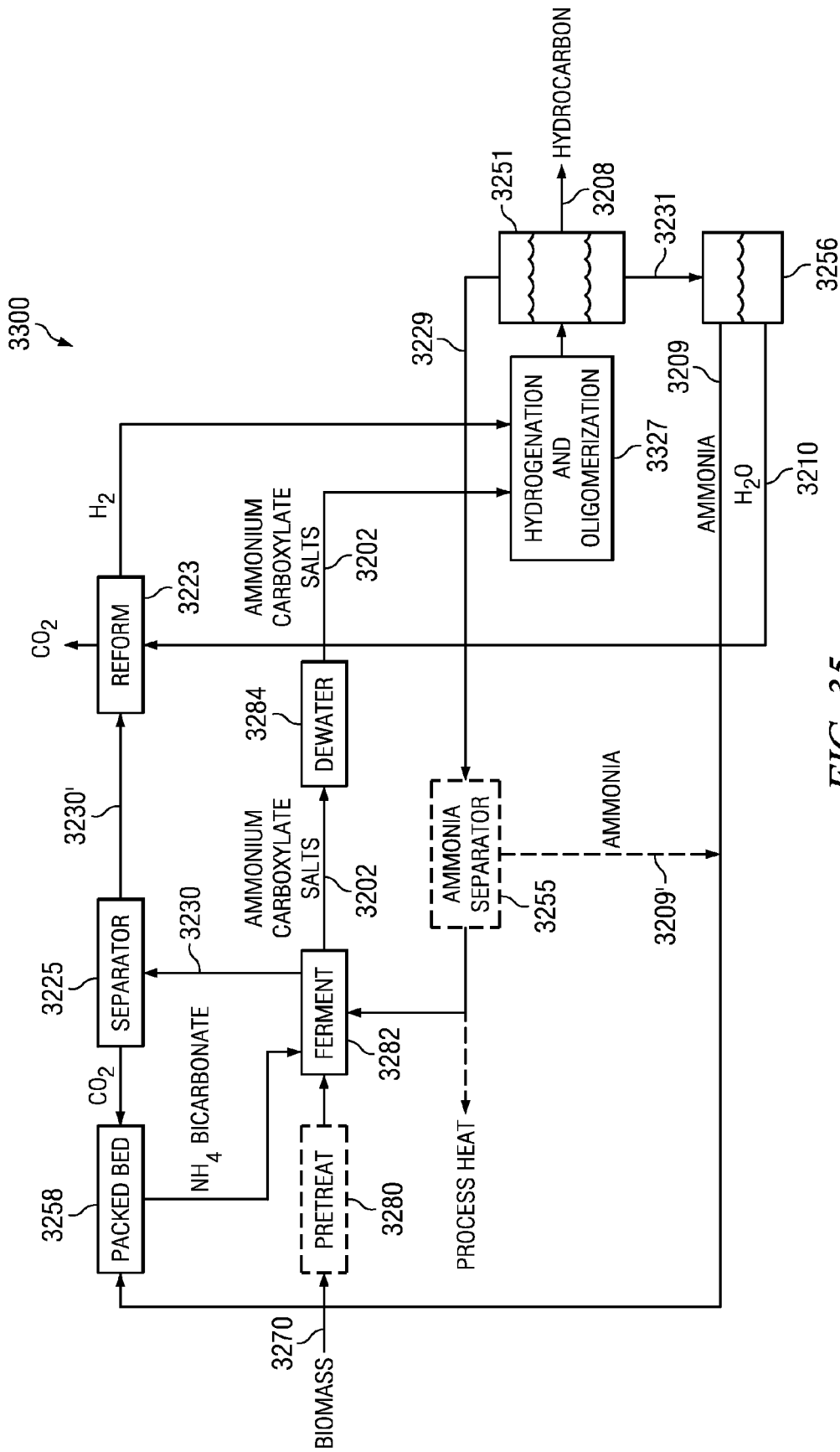

FIG. 35

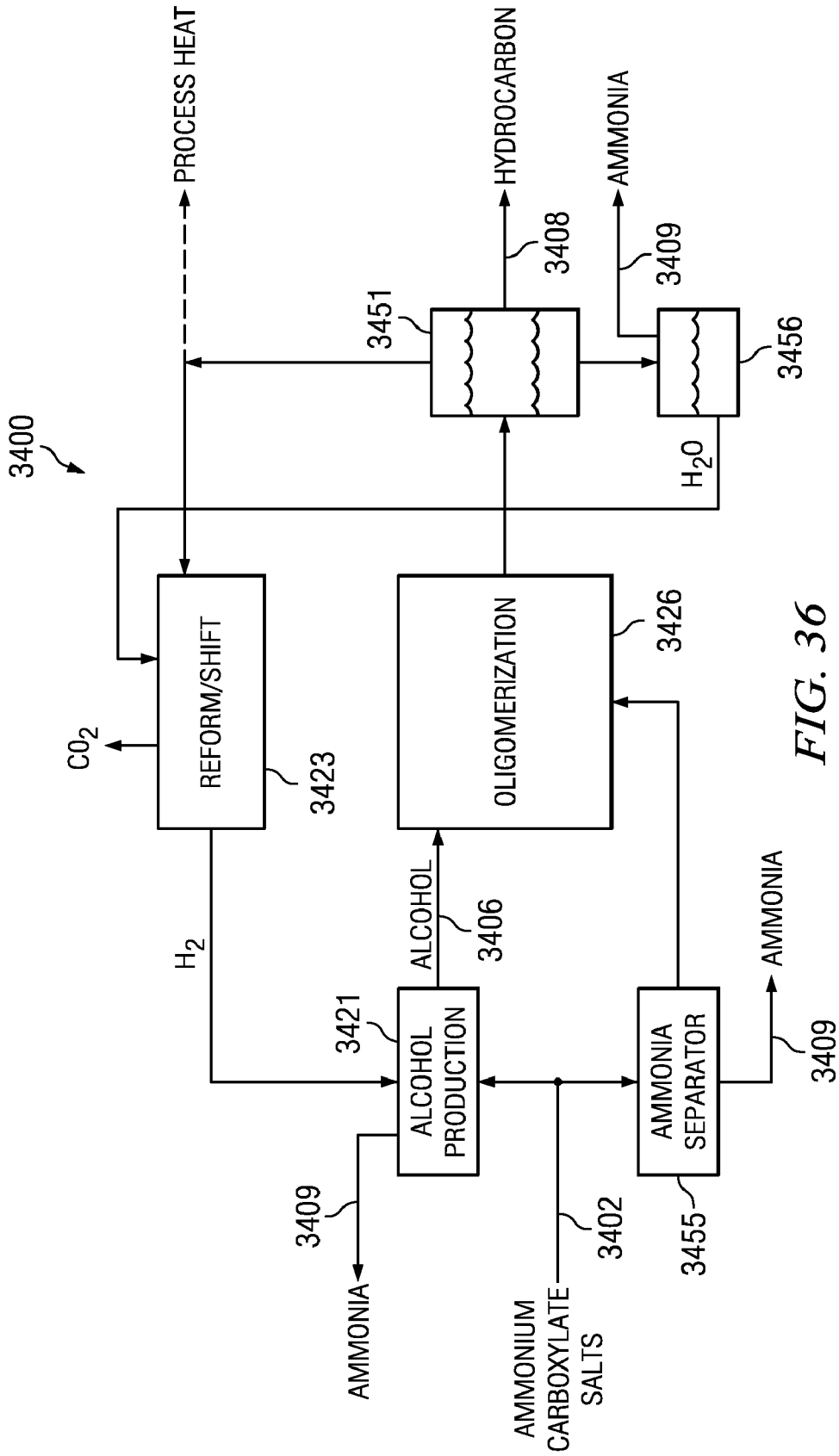

FIG. 36

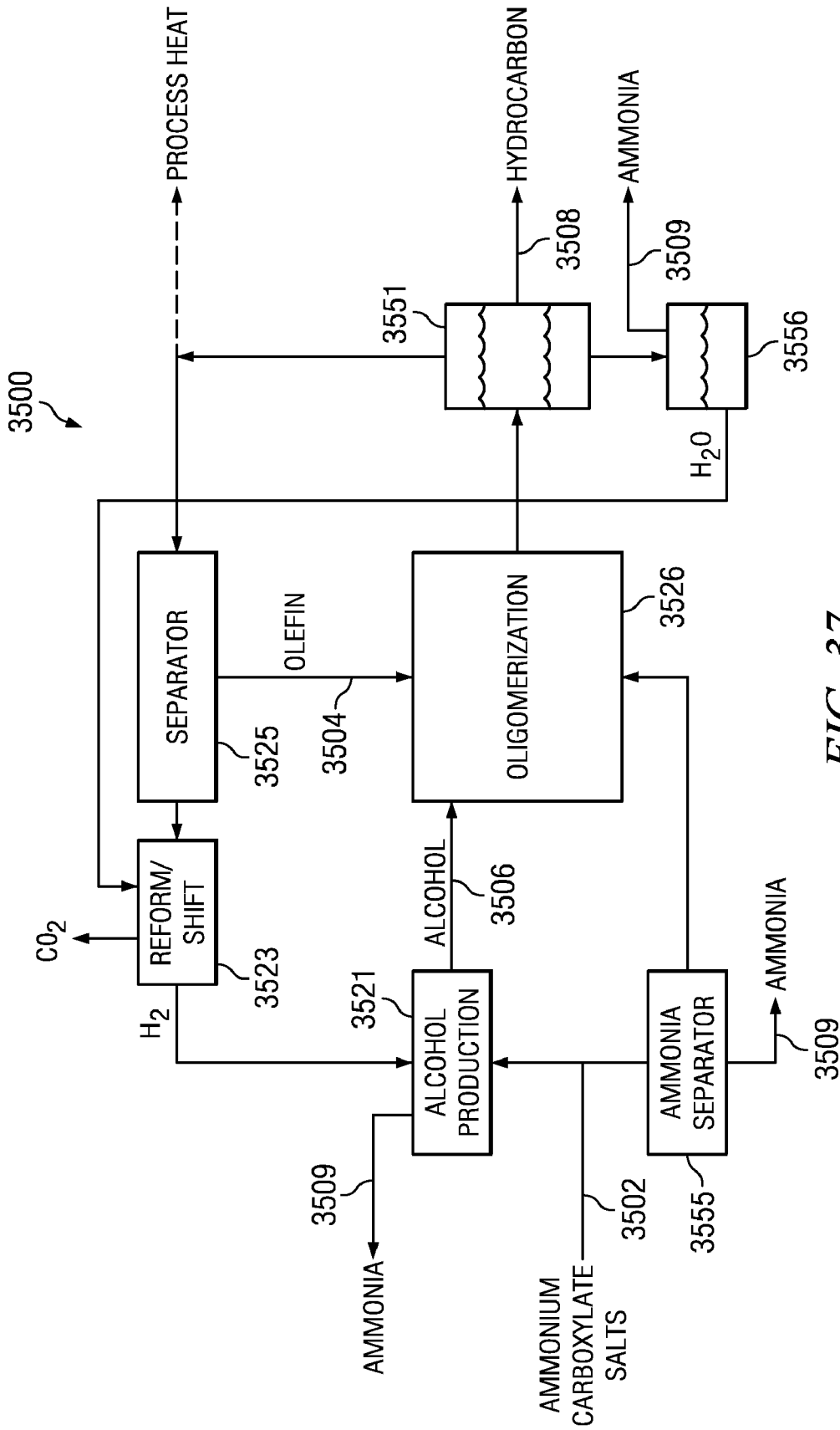

FIG. 37

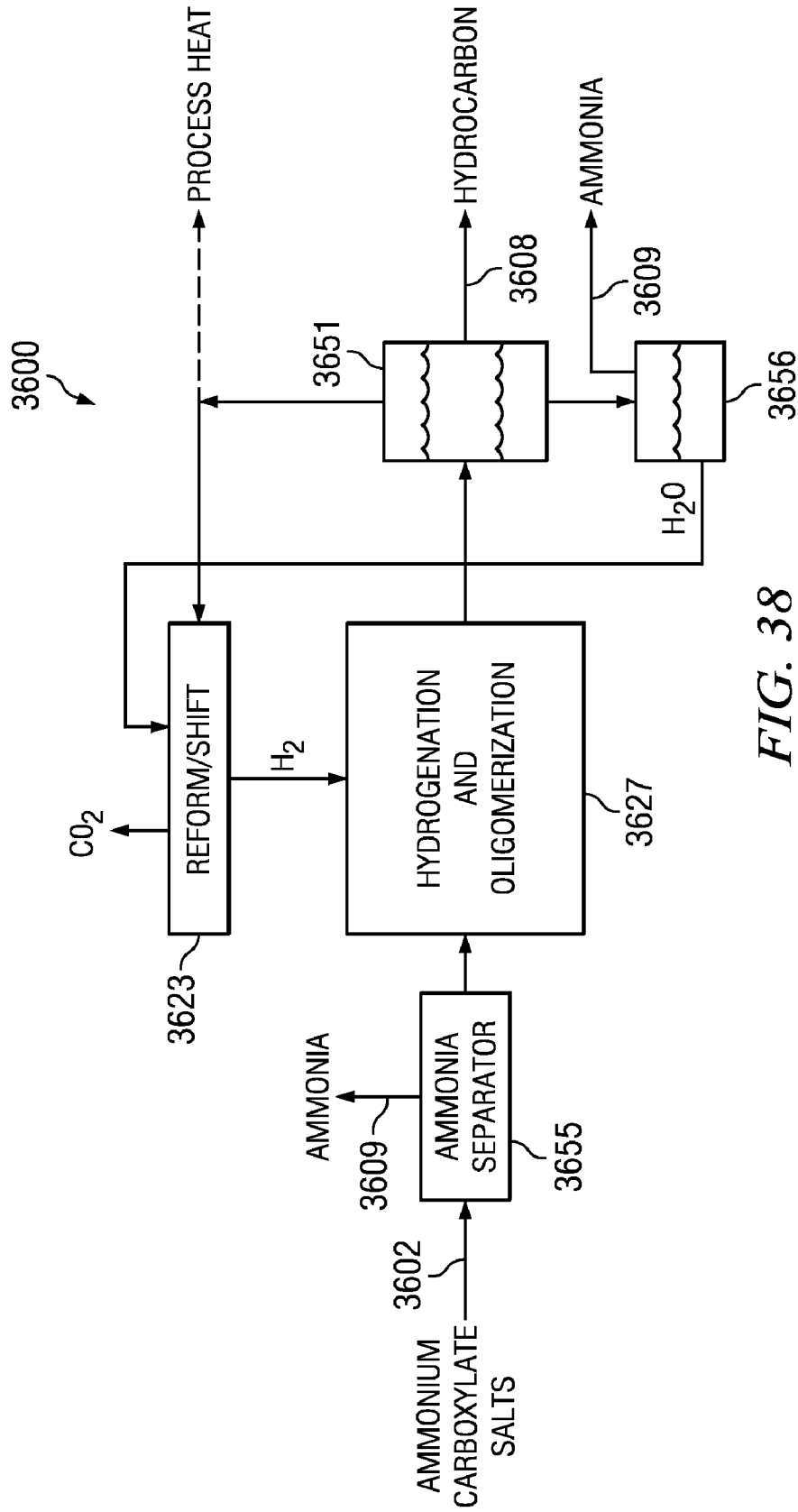

FIG. 38

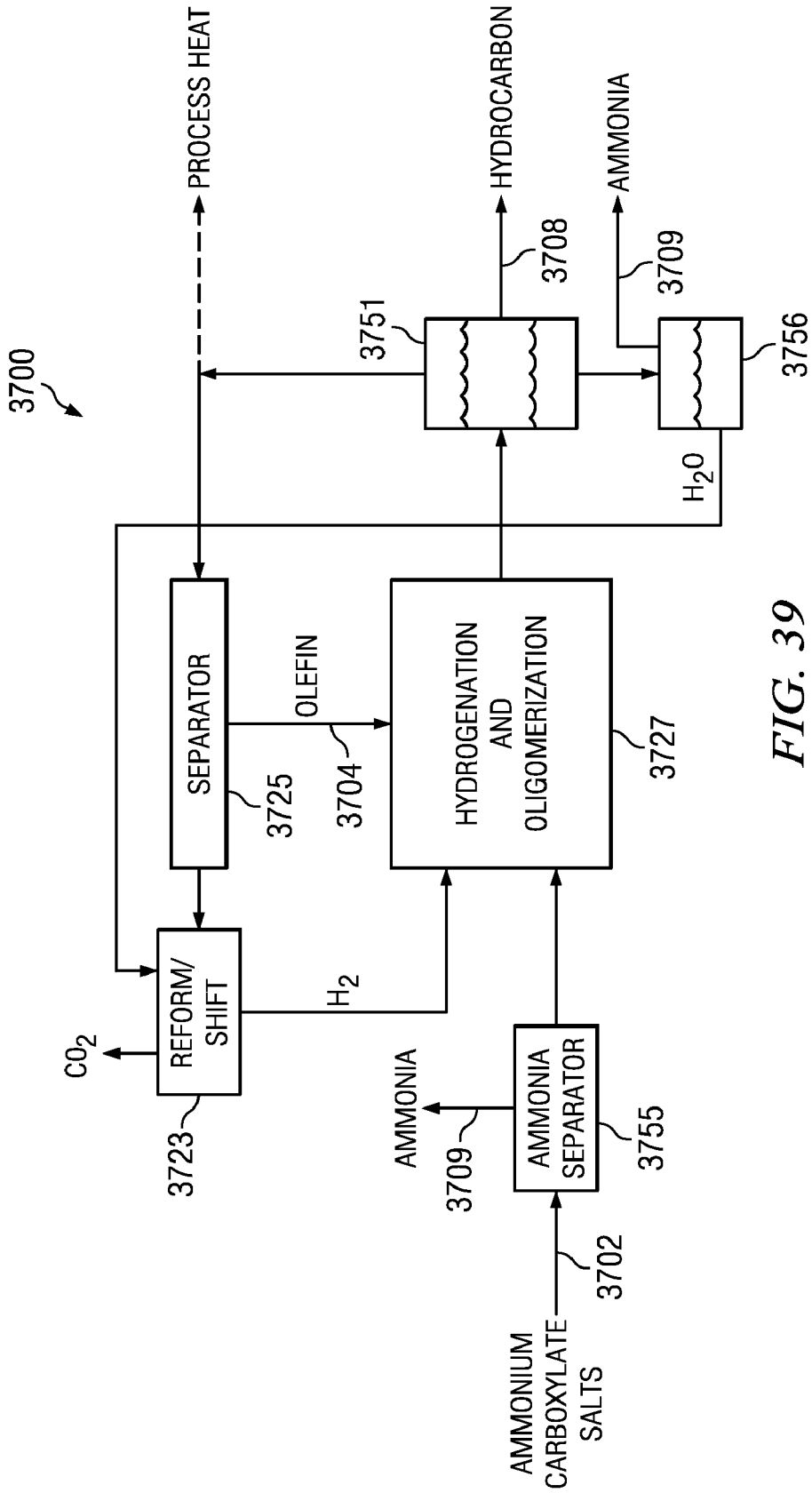

FIG. 39

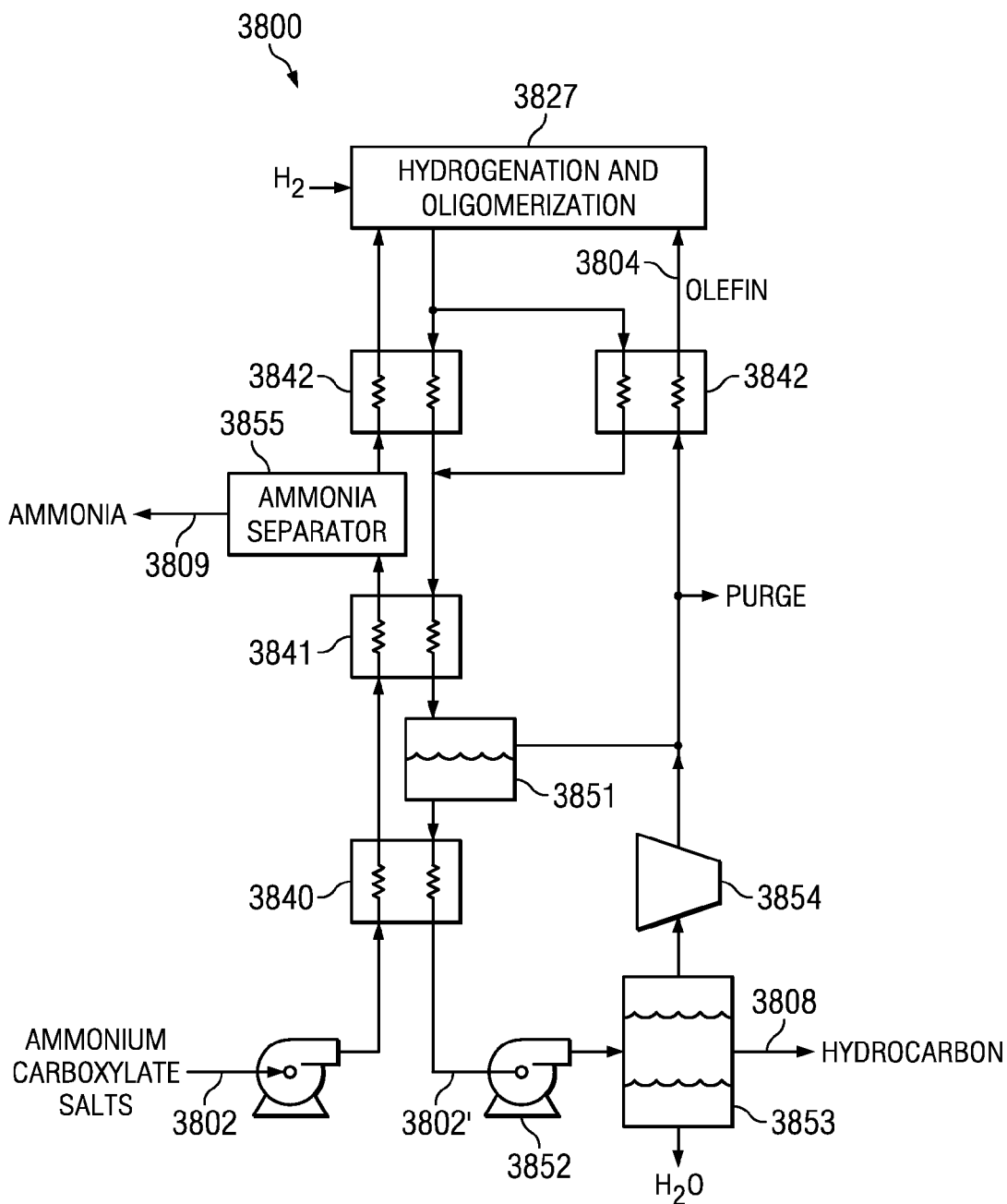

FIG. 40

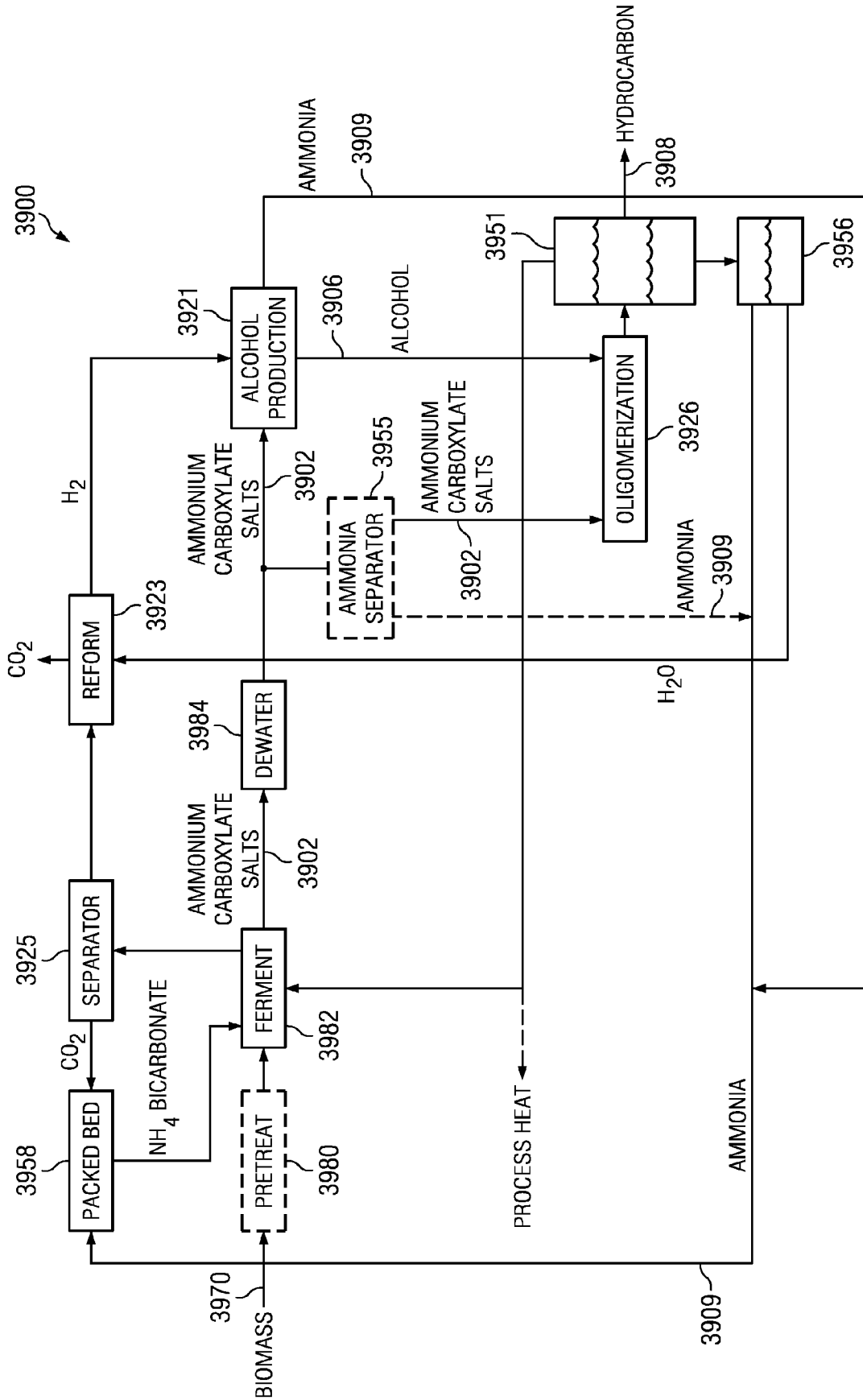

FIG. 41

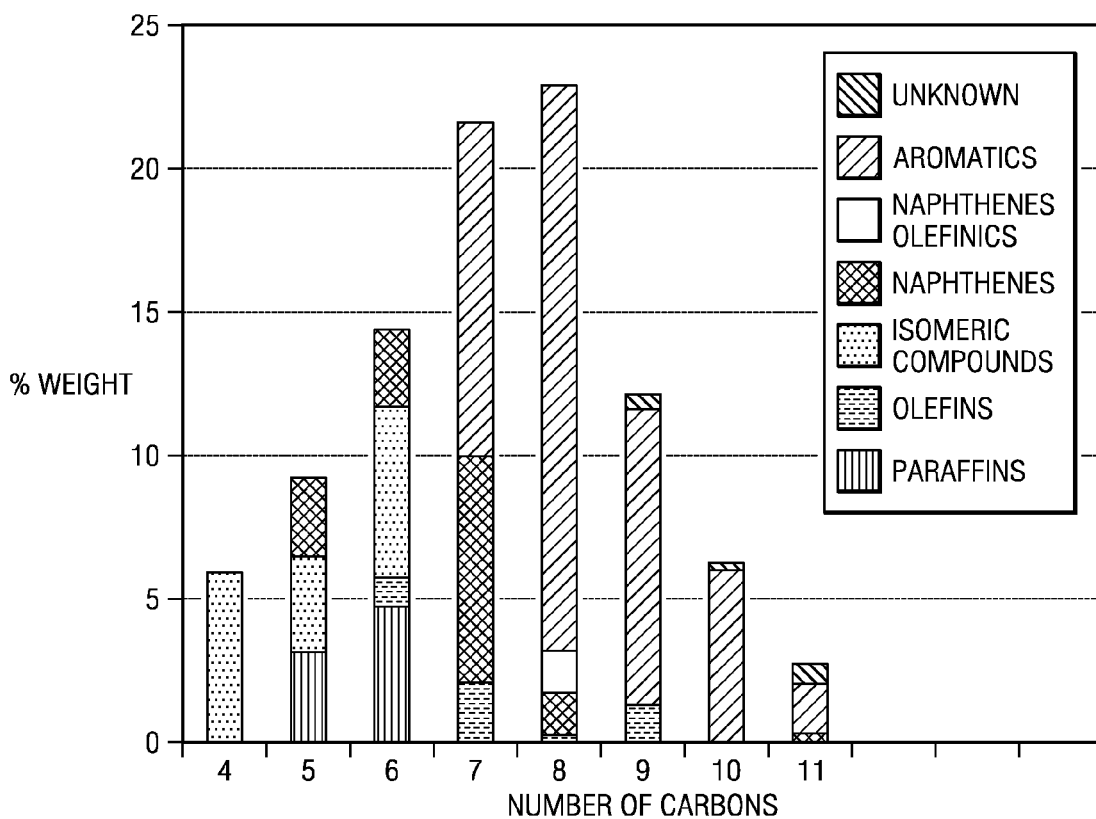

FIG. 43

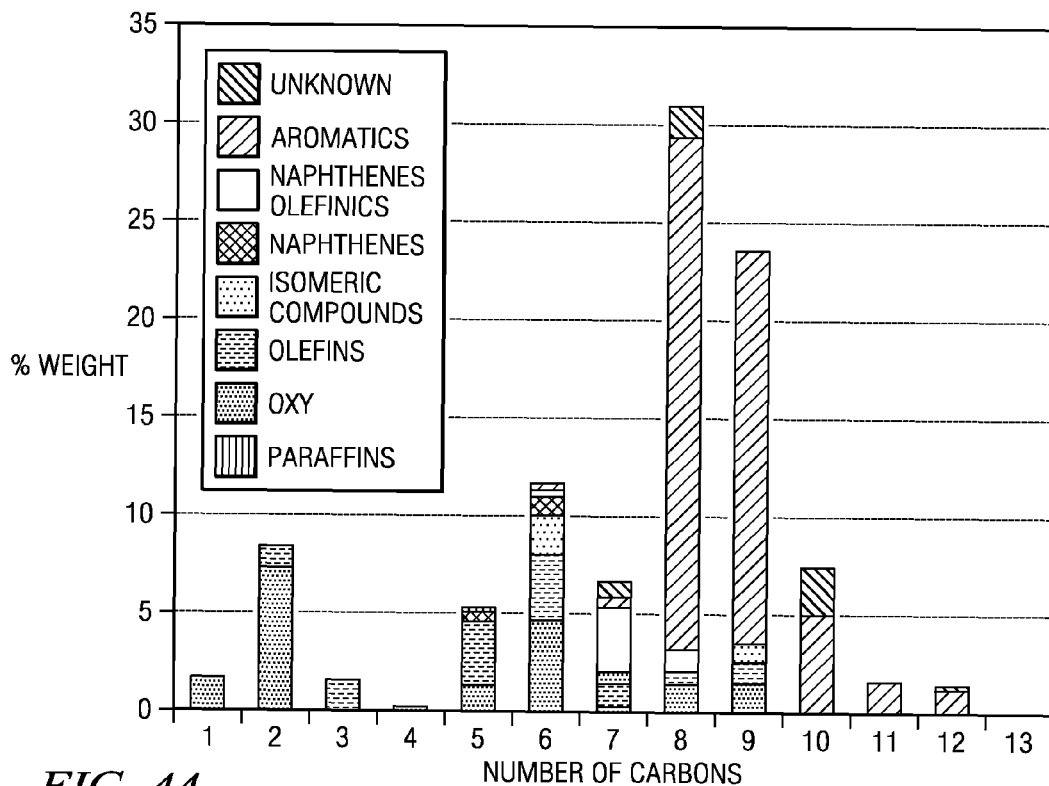

FIG. 44

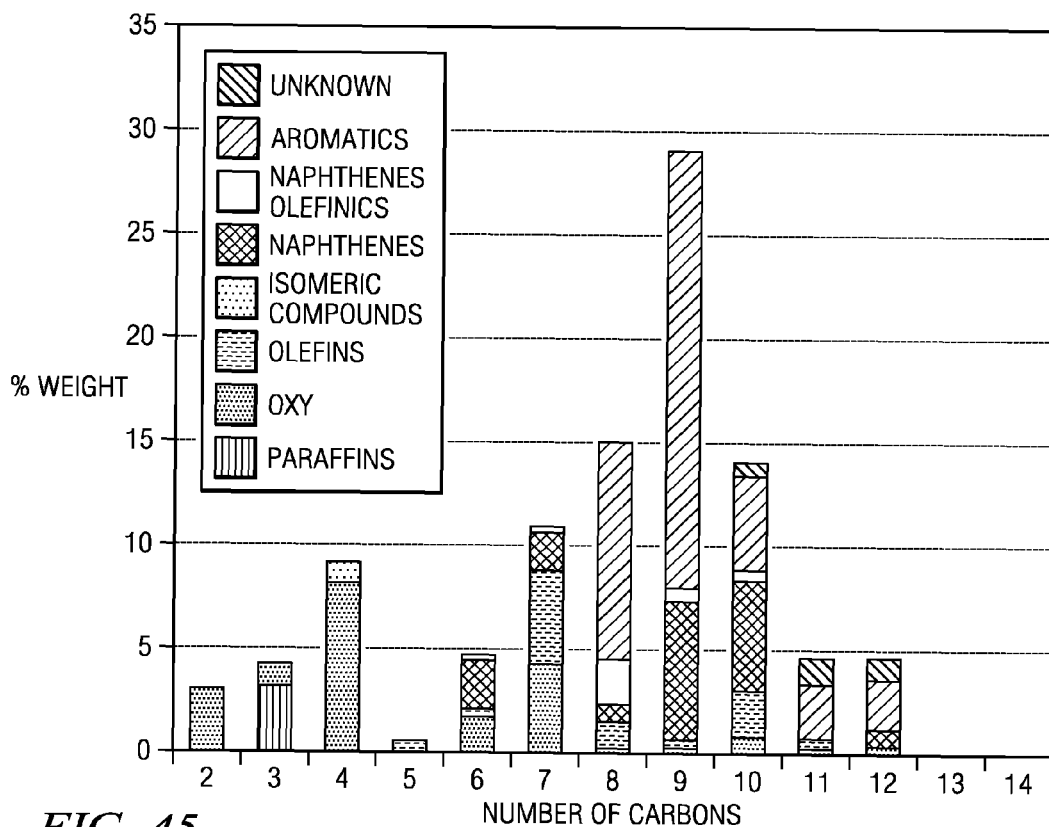

FIG. 45

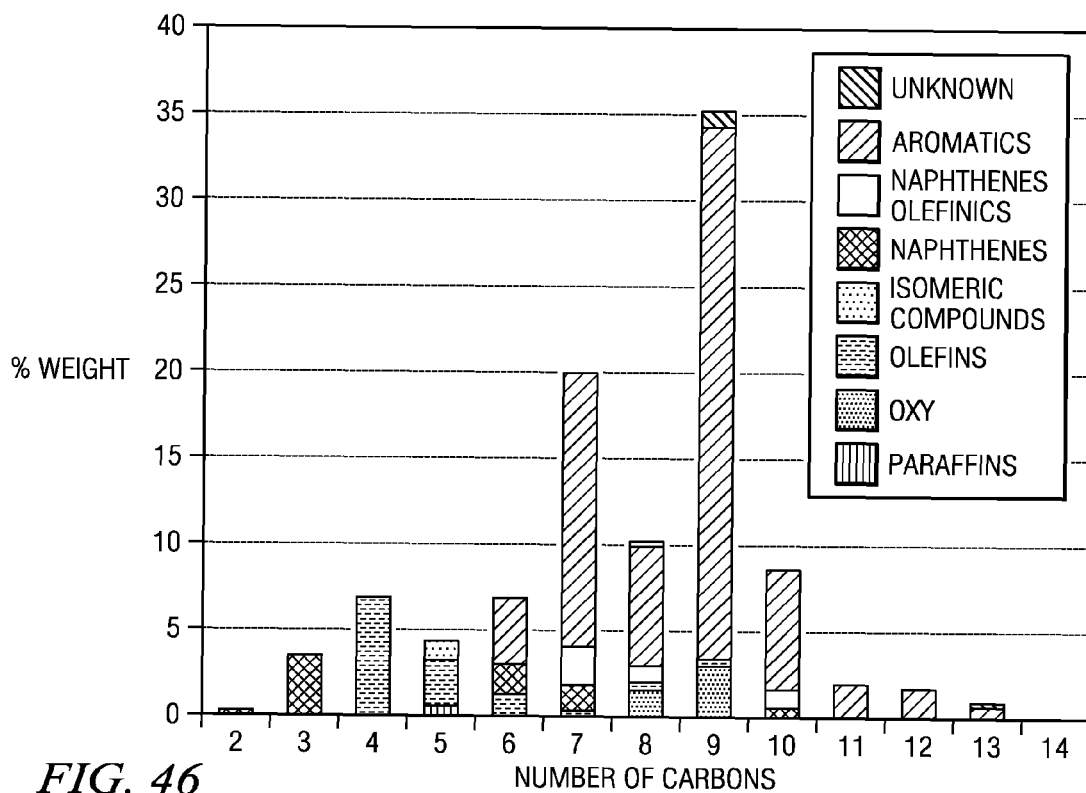

FIG. 46

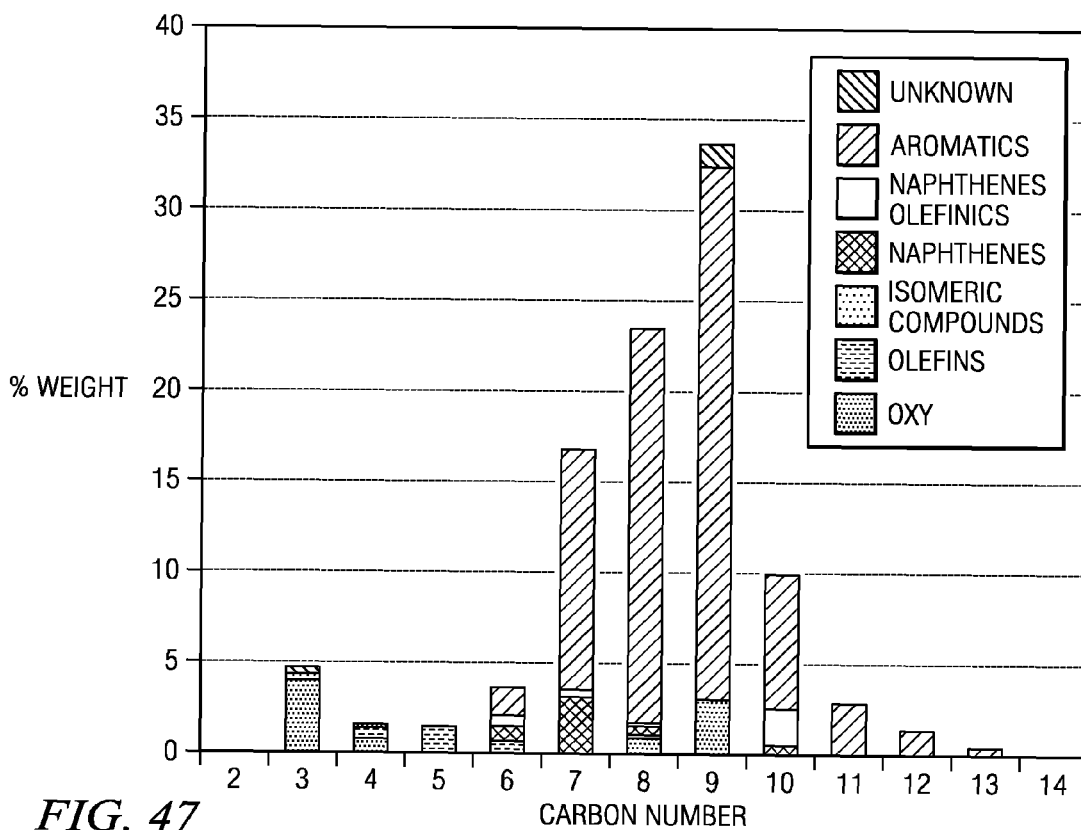

FIG. 47

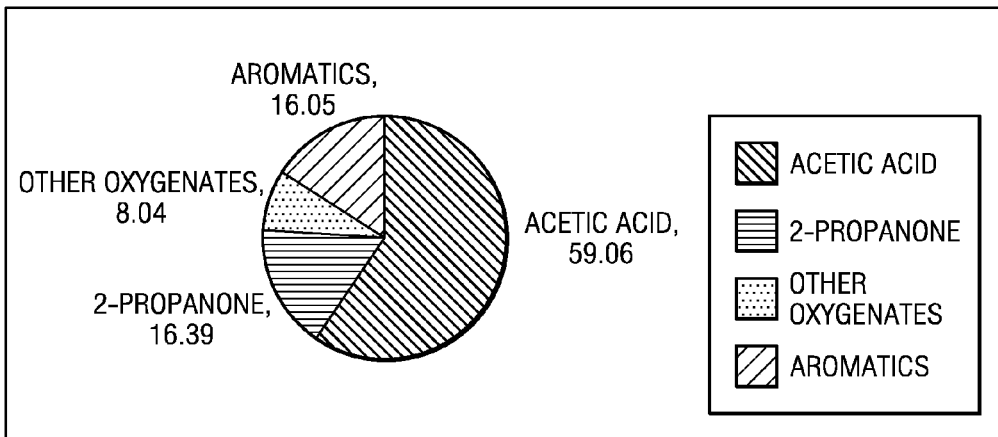

FIG. 48

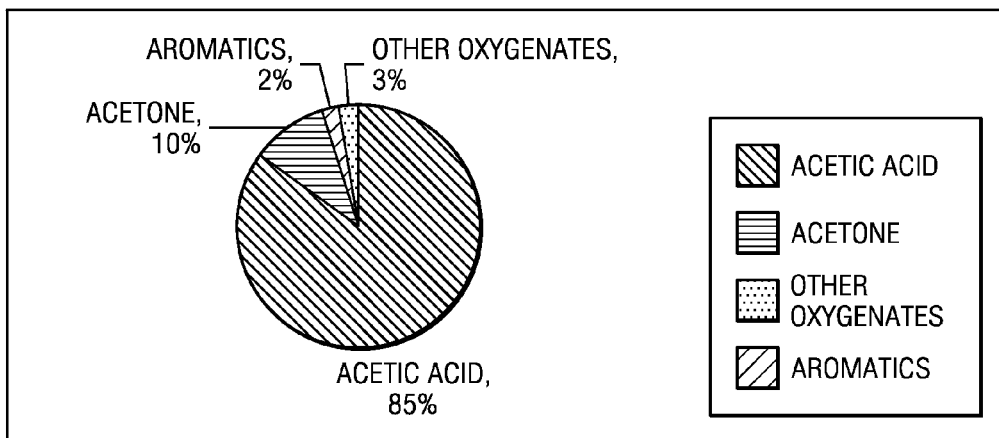

FIG. 49

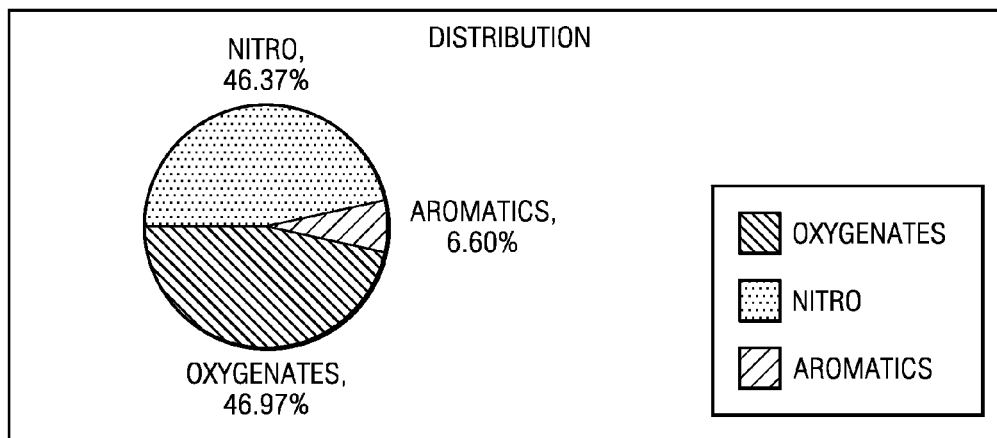

FIG. 50

1

ALTERNATIVE PATHS TO ALCOHOLS AND HYDROCARBONS FROM BIOMASS

CROSS-REFERENCE TO RELATED APPLICATIONS

Pursuant to 35 U.S.C. §119(e), this application claims priority to U.S. Provisional Patent Application No. 61/119,250 which was filed Dec. 2, 2008 and which is hereby incorporated herein by reference.

STATEMENT REGARDING FEDERALLY SPONSORED RESEARCH OR DEVELOPMENT

Not Applicable.

BACKGROUND

1. Technical Field

This disclosure relates to biomass. More particularly, this disclosure relates to alternative paths to alcohols and hydrocarbons from biomass.

2. Background of the Invention

Biomass is biological material that can be converted into fuel. Biofuels may be produced from most biological, carbon sources. For example, biofuels may be produced from sources such as photosynthetic plants. Biofuels may be used in a wide variety of applications, such as for cooking, heating, and transportation.

There are many technologies that produce biofuels from biomass. For example, ethanol may be produced from lignocellulosic biomass. Enzymatic production of free sugars from biomass has been reported. The sugars are then directly fermented to ethanol. Also in the prior art is gasification of biomass to synthesis gas (CO and H₂), which is directly fermented to ethanol, or may be catalytically converted to mixed alcohols. Various technologies enzymatically produce free sugars from biomass, and the sugars are subsequently fermented to acetic acid using homoacetogens. The acetic acid may subsequently be hydrogenated to ethanol using the methods described in U.S. Pat. Nos. 6,927,048 and 7,351,559.

Routes to hydrocarbons include the following: alcohols produced by the above methods can be converted to hydrocarbons using a zeolite catalyst; synthesis gas produced by gasifying biomass can be converted to hydrocarbons by using a Fisher-Tropsch catalyst; sugars may be catalytically converted to hydrocarbons; and biomass may be converted to hydrocarbons by pyrolysis.

Although various technologies exist for producing biofuels from biomass, there is a need in the art for new, improved more efficient systems and processes for the production of alcohols and/or hydrocarbons from biomass.

SUMMARY

Herein disclosed is a method of producing alcohols, hydrocarbons, or both from biomass by converting biomass into a carboxylic acid, reacting the carboxylic acid with an olefin to produce an ester, and hydrogenolyzing the ester to produce alcohol. In embodiments, reacting the carboxylic acid with an olefin to produce an ester and hydrogenolyzing the ester to produce an alcohol are carried out in the same reactor. In embodiments, reacting the carboxylic acid with an olefin to produce an ester and hydrogenolyzing the ester to produce an alcohol are carried out with one catalyst.

2

In embodiments, the method further comprises dehydrating at least a portion of the alcohol to produce an olefin feed, at least a portion of the olefin feed providing the olefin that reacts with the carboxylic acid to produce the ester. In 5 embodiments, reacting the carboxylic acid with an olefin to produce an ester and hydrogenolyzing the ester to produce an alcohol are carried out in the same reactor. In embodiments, reacting the carboxylic acid with an olefin to produce an ester and hydrogenolyzing the ester to produce an alcohol are carried out with one catalyst. The method may further comprise oligomerizing at least another portion of the alcohol to produce hydrocarbons. The method may further comprise oligomerizing at least another portion of the olefin feed to produce hydrocarbons.

In embodiments, the method further comprises oligomerizing at least a portion of the alcohol to produce an olefin feed, at least a portion of the olefin feed providing the olefin that reacts with the carboxylic acid to produce the ester. The method may further comprise oligomerizing at least a portion 20 of the alcohol to produce hydrocarbons. In embodiments, reacting the carboxylic acid with an olefin to produce an ester and hydrogenolyzing the ester to produce an alcohol are carried out in the same reactor. In embodiments, reacting the carboxylic acid with an olefin to produce an ester and hydrogenolyzing the ester to produce an alcohol are carried out with one catalyst. Such method may further comprise oligomerizing at least another portion of the alcohol to produce an olefin 25 feed, at least a portion of the olefin feed providing the olefin that reacts with the carboxylic acid to produce the ester.

In embodiments, converting the biomass into a carboxylic acid further comprises fermenting the biomass to yield a liquid fermentation broth comprising water and carboxylate salts, dewatering the liquid fermentation broth to separate the water from the carboxylate salts, and converting the carboxy- 30 late salts into carboxylic acids.

In embodiments, the method further comprises converting the alcohol into a hydrocarbon. In such embodiments, reacting the carboxylic acid with an olefin to produce an ester and hydrogenolyzing the ester to produce an alcohol may be carried out in the same reactor. In such embodiments, reacting the carboxylic acid with an olefin to produce an ester and hydrogenolyzing the ester to produce an alcohol may be carried out with one catalyst. Converting the alcohol into a hydrocarbon can comprise an oligomerization process. In 45 embodiments, converting the alcohol into a hydrocarbon comprises oligomerizing at least a portion of the alcohol to produce the hydrocarbon. In embodiments, converting the alcohol into a hydrocarbon comprises dehydrating at least a portion of the alcohol to produce an olefin feed, and oligomerizing at least a portion of the olefin feed to produce the hydrocarbon.

Also disclosed is a method of producing hydrocarbons from biomass by converting at least a portion of the biomass into a carboxylic acid, a ketone, or an ammonium carboxylate salt, reacting at least one of a portion of the carboxylic acid, a 55 portion of the ketone, or a portion of the ammonium carboxylate salt in an oligomerization reactor as at least part of a process that produces an oligomerization product, and separating hydrocarbons from the oligomerization product. In embodiments, the method further comprises converting another portion of the carboxylic acid, another portion of the ketone, or another portion of the ammonium carboxylate salt to alcohol, and providing at least a portion of the alcohol to the oligomerization reactor for the process that produces the oligomerization product. Converting the another portion of the 65 carboxylic acid into alcohol may comprise reacting the another portion of the carboxylic acid with an olefin to pro-

duce an ester; and hydrogenolyzing the ester to produce the alcohol. Reacting at least one of the portion of the carboxylic acid, the portion of the ketone, or the portion of the ammonium carboxylate salt in the oligomerization reactor as at least part of the process that produces the oligomerization product and converting the another portion of the carboxylic acid, the another portion of the ketone, or the another portion of the ammonium carboxylate salt to alcohol can be carried out in the oligomerization reactor. Reacting at least one of the portion of the carboxylic acid, the portion of the ketone, or the portion of the ammonium carboxylate salt in the oligomerization reactor as at least part of the process that produces the oligomerization product and converting the another portion of the carboxylic acid, the another portion of the ketone, or the another portion of the ammonium carboxylate salt to alcohol may be carried out with one catalyst.

The method may further comprise separating a recycle stream from the oligomerization product, processing the recycle stream in a reformer to produce hydrogen, and providing a least a portion of the produced hydrogen for the process of converting the another portion of the carboxylic acid, the another portion of the ketone, or the another portion of the ammonium carboxylate salt to alcohol. In embodiments wherein at least a portion of the biomass is converted to the ammonium carboxylate salt, the method may further comprise separating ammonia from the recycle stream prior to processing the recycle stream in a reformer to produce hydrogen. In embodiments, the method further comprises separating olefins from the recycle stream prior to processing the recycle stream in a reformer to produce hydrogen, and providing the olefins to the oligomerization reactor for the process that produces the oligomerization product. In embodiments, at least a portion of the biomass is converted to an ammonium carboxylate salt, and the method further comprises separating ammonia from the recycle stream prior to processing the recycle stream in a reformer to produce hydrogen.

In embodiments, the method further comprises separating a recycle stream from the oligomerization product, separating olefins from the recycle stream, and providing the olefins to the oligomerization reactor for the process that produces the oligomerization product.

In embodiments, at least a portion of the biomass is converted into a carboxylic acid. Converting at least a portion of the biomass into a carboxylic acid may comprise fermenting the biomass to produce a calcium carboxylate salt or an ammonium carboxylate salt, and converting the calcium carboxylate salt or the ammonium carboxylate salt to carboxylic acid using an acid recovery process.

In embodiments, at least a portion of the biomass is converted into a ketone. Converting at least a portion of the biomass into a ketone may comprise fermenting the biomass to produce a calcium carboxylate salt, and thermally converting the calcium carboxylate salt into the ketone. In embodiments, converting at least a portion of the biomass into a ketone comprises fermenting the biomass to produce a calcium carboxylate salt or an ammonium carboxylate salt, converting the calcium carboxylate salt or the ammonium carboxylate salt to carboxylic acid using an acid recovery process, and catalytically converting carboxylic acid into ketone. In embodiments, the method further comprises converting another portion of the ketone into alcohol by hydrogenating the another portion of the ketone.

In embodiments, converting at least a portion of the biomass into a ketone comprises fermenting the biomass to produce a calcium carboxylate salt, and producing hot ketone vapors and calcium carbonate in a ketone reactor operated

with a sweep gas. The sweep gas can be reactive, condensable or both. In embodiments, the sweep gas comprises hydrogen. In embodiments, the sweep gas comprises steam.

In embodiments, at least a portion of the biomass is converted into the ammonium carboxylate salt. Such a method may further comprise converting another portion of the ammonium carboxylate salt to alcohol, and providing the alcohol to the oligomerization reactor for the process that produces the oligomerization product, wherein converting the another portion of the ammonium carboxylate salt into alcohol comprises converting the another portion of the ammonium carboxylate salt into a second carboxylic acid, reacting the second carboxylic acid with an olefin to produce an ester, and hydrogenolyzing the ester to produce the alcohol. In embodiments wherein at least a portion of the biomass is converted into the ammonium carboxylate salt, the method may further comprise separating ammonia from the ammonium carboxylate salt prior to reacting the portion of the ammonium carboxylate salt in the oligomerization reactor as at least part of the process that produces the oligomerization product.

In embodiments, converting at least a portion of the biomass into a carboxylic acid, a ketone, or an ammonium carboxylate salt comprises a fermentation process in a fermenter, and the method further comprises separating a gaseous recycle stream from the oligomerization product and providing at least a portion of the gaseous recycle stream to the fermenter. The method may further comprise converting another portion of the carboxylic acid, another portion of the ketone, or another portion of the ammonium carboxylate salt to alcohol, and providing the alcohol to the oligomerization reactor. In some such embodiments, at least a portion of the biomass is converted into a carboxylic acid. In some such embodiments, at least a portion of the biomass is converted into a ketone. In some such embodiments, at least a portion of the biomass is converted into an ammonium carboxylate salt. Such a method may further comprise separating ammonia from the gaseous recycle stream prior to providing the at least a portion of the gaseous recycle stream to the fermenter.

In embodiments, reacting at least one of the portion of the carboxylic acid, the portion of the ketone, or the portion of the ammonium carboxylate salt in the oligomerization reactor as at least part of the process that produces the oligomerization product and converting the another portion of the carboxylic acid, the another portion of the ketone, or the another portion of the ammonium carboxylate salt to alcohol are carried out in the oligomerization reactor. Reacting at least one of the portion of the carboxylic acid, the portion of the ketone, or the portion of the ammonium carboxylate salt in the oligomerization reactor as at least part of the process that produces the oligomerization product and converting the another portion of the carboxylic acid, the another portion of the ketone, or the another portion of the ammonium carboxylate salt to alcohol can be carried out with one catalyst.

In embodiments, the method further comprises separating fermenter gases exiting the fermenter, processing the fermenter gases in a reformer to produce hydrogen, and providing a least a portion of the produced hydrogen for the process of converting the another portion of the carboxylic acid, the another portion of the ketone, or the another portion of the ammonium carboxylate salt to alcohol.

Although specific advantages are enumerated herein, various embodiments may include all, some, or none of the enumerated advantages. Additionally, other technical advantages

may become readily apparent to one of ordinary skill in the art after review of the following figures and description.

BRIEF DESCRIPTION OF THE DRAWINGS

For a more complete understanding of example embodiments of the present invention and its advantages, reference is now made to the following description, taken in conjunction with the accompanying drawings, in which:

FIGS. 1A and 1B are block diagrams of calcium and ammonia-based biomass conversion systems respectively, according to embodiments;

FIG. 2 is a block diagram showing conversion of carboxylic acids to alcohols, according to an embodiment;

FIG. 3 is a block diagram showing details of a conversion of carboxylic acids to alcohols, according to an embodiment;

FIG. 4 is a block diagram showing conversion of carboxylic acids to alcohols in one single reactor, according to an embodiment;

FIG. 5 is a block diagram showing details of a conversion of carboxylic acids to alcohols in one single reactor, according to an embodiment;

FIG. 6 is a block diagram showing conversion of carboxylic acids to hydrocarbons via olefin and alcohol (Option A), according to an embodiment;

FIG. 7 is a block diagram showing details of a conversion of carboxylic acids to hydrocarbons via olefin and alcohol (Option A), according to an embodiment;

FIG. 8 is a block diagram showing conversion of carboxylic acids to hydrocarbons via olefin and alcohol with the alcohol produced in one single reactor (Option A), according to an embodiment;

FIG. 9 is a block diagram showing details of a conversion of carboxylic acids to hydrocarbons via olefin and alcohol with the alcohol produced in one single reactor (Option A), according to an embodiment;

FIG. 10 is a block diagram showing conversion of carboxylic acids to hydrocarbons via olefin and alcohol (Option B), according to an embodiment;

FIG. 11 is a block diagram showing details of a conversion of carboxylic acids to hydrocarbons via olefin and alcohol (Option B), according to an embodiment;

FIG. 12 is a block diagram showing conversion of carboxylic acids to hydrocarbons via olefin and alcohol with the alcohol produced in one single reactor (Option B), according to an embodiment;

FIG. 13 is a block diagram showing details of a conversion of carboxylic acids to hydrocarbons via olefin and alcohol with the alcohol produced in one single reactor (Option B), according to an embodiment;

FIG. 14 is a block diagram showing conversion of carboxylic acids to hydrocarbons via olefin and alcohol (Option C), according to an embodiment;

FIG. 15 is a block diagram showing details of a conversion of carboxylic acids to hydrocarbons via olefin and alcohol (Option C), according to an embodiment;

FIG. 16 is a block diagram showing conversion of carboxylic acids to hydrocarbons via olefin and alcohol with the alcohol produced in one single reactor (Option C), according to an embodiment;

FIG. 17 is a block diagram showing details of a conversion of carboxylic acids to hydrocarbons via olefin and alcohol with the alcohol produced in one single reactor (Option C), according to an embodiment;

FIG. 18 is a block diagram showing direct conversion of carboxylic acids or ketones to hydrocarbons (Option A1), according to an embodiment;

FIG. 19 is a block diagram showing direct conversion of carboxylic acids or ketones to hydrocarbons (Option B1), according to an embodiment;

FIG. 20 is a block diagram showing direct conversion of carboxylic acids or ketones to hydrocarbons (Option A2), according to an embodiment;

FIG. 21 is a block diagram showing direct conversion of carboxylic acids or ketones to hydrocarbons (Option B2), according to an embodiment;

FIG. 22 is a block diagram showing details of conversion of carboxylic acids or ketones to hydrocarbons (Options A2 and B2), according to an embodiment;

FIG. 23 is a block diagram showing fermentation with direct conversion of ketones to hydrocarbons, according to an embodiment;

FIG. 24 is a block diagram showing fermentation with direct conversion of ketones to hydrocarbons with hydrogenation and oligomerization occurring in the same reactor, according to an embodiment;

FIG. 25 is a block diagram showing complete biomass conversion for calcium-based systems, according to embodiments;

FIG. 26 is a block diagram showing the use of sweep gas and the direct introduction of ketone vapors from a ketone reactor to downstream unit operations, according to an embodiment;

FIG. 27 is a block diagram showing fermentation with direct conversion of carboxylic acids to hydrocarbons, according to an embodiment;

FIG. 28 is a block diagram showing fermentation with direct conversion of carboxylic acids to hydrocarbons with hydrogenation and oligomerization occurring in the same reactor, according to an embodiment;

FIG. 29 is a block diagram showing direct conversion of ammonium carboxylate salts to hydrocarbons (Option A1), according to an embodiment;

FIG. 30 is a block diagram showing direct conversion of ammonium carboxylate salts to hydrocarbons (Option B1), according to an embodiment;

FIG. 31 is a block diagram showing direct conversion of ammonium carboxylate salts to hydrocarbons (Option A2), according to an embodiment;

FIG. 32 is a block diagram showing direct conversion of ammonium carboxylate salts to hydrocarbons (Option B2), according to an embodiment;

FIG. 33 is a block diagram showing details of a conversion of ammonium carboxylate salts to hydrocarbons (Option A2 and B2), according to an embodiment;

FIG. 34 is a block diagram showing fermentation with direct conversion of ammonium carboxylate salts to hydrocarbons, according to an embodiment;

FIG. 35 is a block diagram showing fermentation with direct conversion of ammonium carboxylate salts to hydrocarbons with hydrogenation and oligomerization occurring in the same reactor, according to an embodiment;

FIG. 36 is a block diagram showing direct conversion of ammonium carboxylate salts to hydrocarbons with prior removal of ammonia (Option A1), according to an embodiment;

FIG. 37 is a block diagram showing direct conversion of ammonium carboxylate salts to hydrocarbons with prior removal of ammonia (Option B1), according to an embodiment;

FIG. 38 is a block diagram showing direct conversion of ammonium carboxylate salts to hydrocarbons with prior removal of ammonia (Option A2), according to an embodiment;

FIG. 39 is a block diagram showing direct conversion of ammonium carboxylate salts to hydrocarbons with prior removal of ammonia (Option B2), according to an embodiment;

FIG. 40 is a block diagram showing details of a conversion of ammonium carboxylate salts to hydrocarbons with prior removal of ammonia (Option A2 and B2), according to an embodiment;

FIG. 41 is block diagram showing fermentation with direct conversion of ammonium carboxylate salts to hydrocarbons with ammonia removal prior to oligomerization, according to an embodiment;

FIG. 42 is a block diagram showing fermentation with direct conversion of ammonium carboxylate salts to hydrocarbons with hydrogenation and oligomerization occurring in the same reactor with removal of ammonia prior to the oligomerization, according to an embodiment;

FIG. 43 illustrates the liquid-phase product distribution as a function of hydrocarbon type and number of carbons for isopropanol oligomerization over H-ZSM-5 zeolite (Si/Al ratio 280), according to one example embodiment;

FIG. 44 illustrates the liquid-phase product distribution as a function of hydrocarbon type and number of carbons for acetone oligomerization over H-ZSM-5 zeolite (Si/Al ratio 30), according to one example embodiment;

FIG. 45 illustrates the liquid-phase product distribution as a function of hydrocarbon type and number of carbons for acetone oligomerization over H-ZSM-5 zeolite (Si/Al ratio 280) at 330° C., according to one example embodiment;

FIG. 46 illustrates the liquid-phase product distribution as a function of hydrocarbon type and number of carbons for acetone oligomerization over H-ZSM-5 zeolite (Si/Al ratio 280) at 400° C., according to one example embodiment;

FIG. 47 illustrates the liquid-phase product distribution as a function of hydrocarbon type and number of carbons for acetone and hydrogen oligomerization over H-ZSM-5 zeolite (Si/Al ratio 280), according to one example embodiment;

FIG. 48 illustrates the liquid-phase product distribution for acetic acid oligomerization over H-ZSM-5 zeolite (Si/Al ratio 280), according to one example embodiment;

FIG. 49 illustrates the liquid-phase distribution for acetic acid and hydrogen oligomerization over H-ZSM-5 zeolite (Si/Al ratio 280), according to one example embodiment; and

FIG. 50 illustrates the liquid-phase distribution for ammonium acetate oligomerization over H-ZSM-5 zeolite (Si/Al ratio 280), according to one example embodiment.

DETAILED DESCRIPTION

Herein disclosed are systems and methods of producing alcohols and/or hydrocarbons from biomass. In accordance with an embodiment of this disclosure, a method of producing alcohols or hydrocarbons from biomass includes converting biomass into a carboxylic acid. The carboxylic acid is reacted

with an olefin to produce an ester. The ester is hydrogenolyzed to produce alcohol. The alcohol can then be oligomerized to produce hydrocarbons.

Certain embodiments of this disclosure may provide technical advantages. For example, a technical advantage of one embodiment may include the capability to convert biomass-derived compounds (i.e., carboxylate salts, carboxylic acids, or ketones) to fuels (alcohols, hydrocarbons). Other technical advantages of other embodiments may include a route to ethanol from biomass, prior to hydrogenolysis, reacting carboxylic acids with an olefin rather than with an alcohol (as is more commonly done), thereby avoiding or minimizing the formation of water in the reaction. Yet other technical advantages of other embodiments may include a route to ethanol from biomass, reacting carboxylic acids with an olefin in the presence of hydrogen in the same reactor and with the same catalyst, thus producing alcohols in one step rather than two and avoiding or minimizing the formation of water in the reaction. Yet other technical advantages of other embodiments may include adding hydrogen to the reaction of ketones or carboxylic acids for producing hydrocarbons. Yet other technical advantages of other embodiments may include a direct conversion into hydrocarbons of ammonium carboxylate salts, which have been generated by fermentation of biomass, with and without the addition of hydrogen.

It should be understood at the outset that, although example implementations of embodiments are illustrated below, the systems and methods of this disclosure may be implemented using any number of techniques, whether currently known or not. The present invention should in no way be limited to the example implementations, drawings, and techniques illustrated below. Additionally, the drawings are not necessarily drawn to scale and may not illustrate obvious pieces of equipment such as valves and instrumentation.

Routes to alcohols and hydrocarbons, according to teachings of certain embodiments will be described below. Examples of catalysts and operating conditions that may be utilized in various embodiments are presented in Tables I-V below.

TABLE I

Esterification of Carboxylic Acids and Olefin			
Catalyst	Temperature (° C.)	Pressure (kPa)	Reference
solid acid catalysts (MCM-22, MCM-49, MCM-56, ZSM-5, zeolite-Beta)	50 to 300 200 to 250 (preferable)	450 to 21,000 2200 to 11,000 (preferable)	U.S. Pat. No. 5,973,193

TABLE II

Hydrogenolysis of Ester			
Catalyst	Temperature (° C.)	Pressure (kPa)	Reference
Copper chromite	>200	>4,100	widely used in industry (e.g., for making detergent alcohols from fatty acids)
Reduced CuO—ZnO catalyst	~150	<2,400	World Patent WO 82/03854

TABLE III

Dehydration of Alcohol to Olefin			
Catalyst	Temperature (° C.)	Pressure (kPa)	Reference
ZSM-5 zeolite	20-760		U.S. Pat. No. 4,011,278
Molecular sieve catalyst composition comprises a molecular sieve selected from the group consisting of: SAPO-5, SAPO-8, SAPO-11, SAPO-16, SAPO-17, SAPO-18, SAPO-20, SAPO-31, SAPO-34, SAPO-35, SAPO-36, SAPO-37, SAPO-40, SAPO-41, SAPO-42, SAPO-44, SAPO-47, SAPO-56, AEI/CHA intergrowths, metal containing forms thereof, intergrown forms thereof, and mixtures thereof	200-1000 350-550 (preferable)	0.1 to 5,000 20 to 500 (preferable)	USPTO Patent Application 20060149109
Solid acid catalysts (e.g., zeolites, silica-alumina)	180-300	~100	a.
γ -Al ₂ O ₃ catalyst	410-440		b.
HZSM-5 zeolite modified with Fe, Mn and Co	Various temperatures (optimal 220° C.)		c.
Alumina, titania, and alumina-titania hydrogels catalysts	<400		d.
High-silica zeolite, high- silica zeolite with Fe	<400		e.
ZSM-5 zeolite modified with Zn and Mn	400		f.
Clinoptilolite zeolite modified by contact with NaOH and HCl	350		South African Patent ZA 8907621
HZSM-5 zeolite modified by Mg, Ca, Ba and Sr.	<300		g.

a. Iseo Takahara, Masahiro Saito, Megumu Inaba, Kazuhisa Murata, "Dehydration of ethanol into ethylene over solid acid catalysts," *Catalysis letters* 105(3-4), 249-252 (2005).
b. Li, Ying, Chen, Xiao Chun, Sun, Wei; Liu, Shi Wei; Hou, Wei, "Experimental study of the catalytic dehydration of ethanol to ethylene on a γ -Al₂O₃ catalyst," *Ziran Kexueban* 34(5), 449-452 (2007).
c. Hu, Yaohui; Huang, He; Shi, Haifeng; Hu, Yi; Yan, Jie; Chen, Li, "Catalytic dehydration of ethanol to ethylene using transition metal modified HZSM-5," *Huaxue Yu Shengwu Gongcheng* 24(2), 19-21 (2007).
d. Mostafa, M. R., Youssef, A. M., Hassan, S. M., "Conversion of ethanol and isopropanol on alumina, titania and alumina titania catalysts," *Material Letters* 12, 207-213 (1991).
e. Cursetji, R. M.; Singh, A. N.; Deo, A. V., "Ethylene from ethyl alcohol on high silica zeolite catalyst," *Chemical Age of India* 37(6), 407-410 (1986).
f. Le Van Mao, R., Levesque, P., McLaughlin, G., Dao, L. H., "Ethylene from ethanol over zeolite catalysts," *Applied Catalysis* 34, 163-179 (1987).
g. Huang, X. Hu, Y., Li, H., Huang, H., Hu, Y., "Study on dehydration of ethanol to ethylene catalyzed by alkaline-earth metal modified HZSM-5," *Huaxue Shiji* 29(12), 705-707 (2007).

TABLE IV

Oligomerization of Alcohols, Carboxylic Acids, or Ketones to Hydrocarbons			
Catalyst	Temperature (° C.)	Pressure (kPa)	Reference
H-ZSM-5 (Si/Al ratio >12)	260-540	Atmospheric to 20,700	U.S. Pat. No. 3,894,106
ZSM-5, ZSM-11, ZSM-12, ZSM-21, TEA Mordenite (Si/Al ratio >12) H form	260-540		U.S. Pat. No. 3,894,107
Alumina, silica-alumina, acid activated clay, sodium- poisoned H-ZSM-5 zeolite, H-ZSM-5 zeolite (Si/Al >30)	380-540		U.S. Pat. No. 3,928,483
ZSM-5, ZSM-11, ZSM-12, ZSM-23, ZSM-35, ZSM- 38, ZSM-48 (Si/Al ratio >12), H form	290-540		U.S. Pat. No. 4,359,595

TABLE IV-continued

Oligomerization of Alcohols, Carboxylic Acids, or Ketones to Hydrocarbons			
Catalyst	Temperature (° C.)	Pressure (kPa)	Reference
Ruthenium supported in catalytically active amount composed with titania or titania-containing support	150-350	1,100-5,520	U.S. Pat. No. 4,513,161
Silica-alumina, Y zeolite, mordenite, binary oxides, beta zeolites, zeolite L, MAZ, alumina-expanded bentonite clay, USY, REY, ZSM-5, FER, GME, MTW, erionite and crystalline silicon-aluminum	300-500	Atmospheric to 3,500	U.S. Pat. No. 5,191,142
phosphate molecular sieves, crystalline borosilicates			

TABLE IV-continued

Oligomerization of Alcohols, Carboxylic Acids, or Ketones to Hydrocarbons			
Catalyst	Temperature (° C.)	Pressure (kPa)	Reference
Beta zeolite (Si/Al ratio 12.5, 37.5, 75), mordenite (MOR) (Si/Al ratio 45), ultra stable Y (USY) zeolite (Si/Al ratio 30), ferrierite (Si/Al ratio 27.5), faujasite	200-500		a.
H-ZSM-5 zeolite			b.
Beta, H-ZSM-5, Y zeolites	300-400		c.
H-ZSM-5 (Si/Al ratio 25) zeolites	300-500	130	d.
Heteropolyacid compounds of molybdenum and tungsten and ammonium 12-tungstophosphate	300-400		e.
Amorphous silica-alumina (Si/Al ratio 11.3)	310-450	Atmospheric	f.
ZSM-5 zeolite			g.
Triflic acid (TFA or trifluoromethane sulfonic acid) bearing ZSM-5 zeolite	200-210		h.

a. Aramendía, M. A., Borau, V., Jiménez, C., Marinas, J. M., Roldán, R., "Catalytic application of zeolites in methanol conversion to hydrocarbons," *Chemistry Letters* 31(7), 672-673 (2002).

b. Udrea, I., Udrea, M., Frunza, L., Angelescu, E., Onu, P., Ginju, D., "Conversion of C1-C4 alcohols to hydrocarbons over ZSM-5 type zeolites," *Heterogeneous Catalysis 6th* (Pt.2) (1987).

c. Hutchins, G. J., Johnston, P., Lee, D. F., Warwick, A., Williams, C. D., Wilkinson, M., "The conversion of methanol and other O-compounds to hydrocarbons over zeolite β ," *Journal of catalysis* 147, 117-185 (1994).

d. Setiadi, S., Kojima, T., Tsutsui, T., "Conversion of acetone to aromatic chemicals with HZSM-5," *Journal of the Japan Institute of Energy* 82(12), 926-932 (2003).

e. Hayashi, H., Moffat, J. B., "Conversion of methanol into hydrocarbons over ammonium 12-tungstophosphate," *Journal of Catalysis* 83, 192-204 (1983).

f. Comelli, R. A., Figoli, N. S., "Transformation of C1-C4 alcohols into hydrocarbons on an amorphous silica-alumina catalyst," *Applied Catalysis* 36, 299-306 (1988).

g. Costa, E.; Aguado, J.; Ovejero, G.; Canizares, P., "Synthesis of hydrocarbons starting from fermentation products," *Revista de la Real Academia de Ciencias Exactas, Fisicasy Naturales de Madrid* 79(3), 453-456 (1985).

h. Le Van Mao, R., Huang, L., "The bioacids/bioacetone-to-hydrocarbons (BATH) process," *Chemical Industries* 46 (novel prod. methods ethylene), 425-442 (1992).

TABLE V

Hydrogenation of Ketones			
Catalyst	Temperature (° C.)	Pressure (kPa)	Reference
Raney nickel	~130	~1,500	a.
Zeolites A, X, Y and mordenite (MOR) in forms of Na, Ca, NH ₄ , Ce and rare-earth elements (REE)	200-450	3,040	b.
Platinum catalysts (Pt/TiO ₂ , Pt/ η -Al ₂ O ₃ , Pt/SiO ₂ , Pt powder, and Pt/Au)	30-90, >90	100	c.
Palladium	100-250	atmospheric	c., d.
Copper Chromite	20-300		e.
Copper oxide-chromium oxide catalyst	60-200	200-1100	Japan Patent JP 03041038
Supported ruthenium catalyst (support: silica, alumina, carbon, kieselguhr, and calcium carbonate)	75-180	350-6900	U.S. Pat. No. 5,495,055

a. Chang, N., Aldrett, S., Holtzapfel, M. T., Davison, R. R., "Kinetic studies of ketone hydrogenation over Raney nickel catalyst," *Chemical Engineering Science* 55(23), 5721-5732 (2000).

b. Minachev, Kh. M., Garanin, V. I., Kharlamov, V. V., Kapustin, M. A., "Hydrogenation of acetone on cationic forms of zeolites," *Russian Chemical Bulletin* 23(7), 1472-1475 (1974).

c. Sen, B., Vannice, M. A., "Metal-support on acetone hydrogenation over platinum catalysts," *Journal of Catalysis* 113, 52-71 (1988).

d. van Druften, G. M. R., Poncé, V., "Promotion effects in the hydrogenation of propanal and acetone over palladium," *React. Kinet. Catal. Lett.* 68(1), 15-23 (1999).

e. Yuriev, T. M., "Mechanisms for activation of hydrogen and hydrogenation of acetone to isopropanol and of carbon oxides to methanol over copper-containing oxide catalysts," *Catalysis Today* 51, 457-467 (1999).

When referring to particular product streams herein, it should be understood that, although the primary product and products are described, other products may exist in the product stream. As one non-limiting example, described in more detail below, a stream of water may contain alcohol.

FIGS. 1A and 1B show block diagrams of embodiments of complete biomass conversion with two options depending of what buffering system is chosen for the fermentation. FIG. 1A shows a calcium-based system 100A, and FIG. 1B shows an ammonia-based system 100B.

According to FIGS. 1A and 1B, pretreatment and fermentation of biomass occurs at Step 110A/110B. Pretreatment is optional depending on whether the biomass is sufficiently digestible "as is." Pretreatment may be performed as known in the art, for example, by using lime pretreatment as described in, but not limited to, U.S. Pat. Nos. 5,693,296 and 5,865,898, and U.S. Patent App. Nos. 60/423,288 and 60/985,059. The digestible biomass may then be directly fermented to carboxylate salts. Such fermentation to carboxylate salts may be performed, for example, as described in, but not limited to, U.S. Pat. No. 5,962,307 and U.S. patent application Ser. Nos. 11/298,983 and 11/456,653. Depending on the buffering system utilized, the carboxylate salts produced in embodiments are calcium or ammonium salts. From the fermentation, a liquid fermentation broth may be obtained, which is mostly water and carboxylate salts. For further treatment, the carboxylate salts may be dewatered at Step 120A/120B. Dewatering may be performed, for example, using processes or systems described in, but not limited to, U.S. Pat. Nos. 5,986,133, 7,251,944, and 7,328,591, and U.S. Pat. App. No. 60/985,059. Teachings of certain embodiments recognize that dewatering may produce concentrated carboxylate salts. In some embodiments, the water produced by step 120A/120B may be used as an input at step 110A/110B.

In calcium-based system 100A, the calcium carboxylate salts may undergo thermal conversion into ketones at step 125A. Systems and processes for effecting such thermal conversion into ketones are described, for example, in U.S. Pat. Nos. 6,043,392 and 6,262,313. In addition, carboxylic acids may be recovered from the salts at step 130A. Recovery of carboxylic acids may be effected via "acid springing," for example, as described in, but not limited to, U.S. Pat. No. 6,395,926. The resulting carboxylic acids or ketones may then be sent downstream to be processed at step 140A, as described in FIGS. 2-24, 27 and 28. Alternatively or additionally, the formation of ketones using, for example, thermal conversion as described in FIGS. 1A and 25 (Step 125A) may be integrated with the appropriate downstream processing as described in FIGS. 18-24, using a sweep gas as described in FIG. 26. Ketones/ketone vapors may also be generated by passing carboxylic acids through a catalytic bed of, for example, zirconium oxide.

In the ammonia-based system 100B, the carboxylic acids may be recovered from the ammonium carboxylate salts at step 130B. Recovery of carboxylic acids may be effected via "acid springing," for example, as described in, but not limited to, U.S. patent application Ser. No. 11/456,653. The resulting carboxylic acids may be sent downstream to be processed at step 140B, as described in FIGS. 2-22, 27 and 28. Alternatively or additionally, the ammonium carboxylate salts may be sent directly downstream to be processed as described in FIGS. 29-42.

In both the calcium-based system 100A and the ammonia-based system 100B, hydrogen may be added to step 140A/140B as needed. The hydrogen may be generated off-site and delivered (e.g., via pipeline or other suitable device), or it may be generated on site from gasification of the undigested fer-

13

mentation residue, from steam reforming of natural gas, from the waste hydrocarbon gases generated in the conversion, or from other suitable methods. In addition, some hydrogen is produced in the fermentation step 110A/110B that may be recovered in a manner similar as described in, but not limited to, U.S. patent application Ser. No. 11/948,506. Teachings of certain embodiments recognize that highly-pure hydrogen may not be required.

FIG. 2 shows a block diagram of a system 200 for converting carboxylic acids to alcohols, according to an embodiment. Carboxylic acids 202 are esterified by reacting with olefins 204 in an esterification reactor 220. The resulting esters 205 are hydrogenolyzed to alcohols 206 in a separate hydrogenolysis reactor 222. A portion of alcohol product 206 may be dehydrated to form olefins 204 in a dehydration reactor 224; the remaining alcohol 206 may be harvested as product. If desired, the alcohol products 206 exiting the hydrogenolysis reactor 222 can be separated by distillation. The higher alcohols can be dehydrated to form higher olefins (propylene and above). Teachings of certain embodiments recognize that using olefins instead of primary alcohols may enable the esterification reactor 220 to produce ester without producing water.

FIG. 3 shows a detailed description of system 200 for converting carboxylic acids to alcohols, according to an embodiment. In this embodiment, the carboxylic acid stream 202 is split into two portions 202a and 202b. Stream 202a is sent to sensible heat exchanger 240, latent heat exchanger 241, and sensible heat exchanger 242, such that the stream 202a becomes superheated vapor. Stream 202b is sent to sensible heat exchanger 243, latent heat exchanger 244, and sensible heat exchanger 245, such that the stream 202b becomes superheated vapor. The superheated carboxylic acid vapor streams 202a and 202b react with olefins 204 in esterification reactor 220 to form esters 205. In some embodiments, esterification reactor 220 has its own temperature control system. Esters 205 react with hydrogen in a hydrogenolysis reactor 222 to produce alcohols 206. In some embodiments, hydrogenolysis reactor 222 has its own temperature control system.

Alcohol product stream 206 is split into two streams 206a and 206b. Stream 206a enters expander 246, where the pressure is reduced. The low-pressure alcohol enters dehydration reactor 224. Teachings of certain embodiments recognize that lowering the pressure in expander 246 may improve dehydration performance because dehydration tends to occur at lower pressure. In some embodiments, dehydration reactor 224 has its own temperature control system. Stream 206a (comprising olefins 206aa and water 206ab) exiting dehydration reactor 224 may then be compressed in compressor 247 and enter sensible heat exchanger 245 and latent heat exchanger 244, which cools the stream and allows water 206ab to condense. Olefin 206aa and water 206ab may then be separated in tank 248. Olefin 206aa is heated in sensible heat exchanger 245 so it can enter esterification reactor 220 as all or part of the olefin 204. The water 206ab exiting tank 248 is cooled in sensible heat exchanger 243. In some embodiments, water 206ab may flow through a turbine 249 as part of a high-pressure liquid 206ab' to recover expansion energy. The liquid 206ab' has primarily water, but it may also have some alcohols because the dehydration reaction in dehydration reactor 224 is reversible. The alcohols in liquid 206ab' are recovered by distillation in column 250 and returned to the alcohol stream 206.

Stream 206b, which represents the portion of the alcohol that is recovered as product, is cooled through sensible heat exchanger 242, latent heat exchanger 241, and sensible heat exchanger 240. The gas space in tank 251 may contain hydro-

14

gen, which may be then recycled to hydrogenolysis reactor 222. In some embodiments, the stream 206b may flow through a turbine 252 as part of a high-pressure liquid 206b' to recover expansion energy. The gas space in tank 253 may contain hydrogen, which is compressed using compressor 254. A portion thereof may be returned via line 206bb to hydrogenolysis reactor 222.

Recycle stream 206bb may contain non-hydrogen gases, which may be purged via line 206bb' in certain embodiments to prevent accumulation within the system. The purged gases in line 206bb' may be sent to a separator to recover the hydrogen, or they may be burned for process heat. Esterification reactor 220 and/or hydrogenolysis reactor 222 can operate at a higher pressure (~2000 to 4000 kPa), whereas dehydration reactor 224 operates at a lower pressure (~20 to 500 kPa), according to certain embodiments. In the illustrated embodiment, expander 246 recovers energy from the pressure reduction and allows it to supplement the energy used by compressor 247.

Certain catalysts, such as zeolites, exhibit both hydrogenation activity (e.g., but not limited to, Minachev, Kh. M., Garinin, V. I., Kharlamov, V. V., Kapustin, M. A., "Hydrogenation of acetone on cationic forms of zeolites," *Russian Chemical Bulletin* 23(7), 1472-1475 (1974)) and they also promote the reaction of olefins and carboxylic acids to produce esters (e.g., but not necessarily limited to, U.S. Pat. No. 5,973,193). Therefore, according to teachings of certain embodiments, both the hydrogenation and esterification for making alcohols may be performed in one single reactor. FIG. 4 shows a simplified diagram of system 200 with the conversion of carboxylic acids to alcohols occurring in one single reactor 221, according to an embodiment. FIG. 5 shows the detailed system 200 described in FIG. 3, but with the esterification reactor 220 and hydrogenolysis reactor 222 combined into one single reactor 221.

FIG. 6 shows a block diagram of a system 600 ("Option A") for converting carboxylic acids to hydrocarbons, according to an embodiment. Carboxylic acids 602 react with olefins 604 in an esterification reactor 620 to form esters 605. The esters 605 react with hydrogen in a hydrogenolysis reactor 622 to form alcohol 606. A portion of the alcohol stream 606 is sent to the dehydration reactor 624 to produce olefins 604 and water. The remaining portion of the alcohol stream 606 is sent to the oligomerization reactor 626, where it forms hydrocarbons 608 and water.

FIG. 7 shows a detailed description of Option A according to one embodiment. Carboxylic acid stream 602 is split into two portions, 602a and 602b. Stream 602a is sent to sensible heat exchanger 640, latent heat exchanger 641, and sensible heat exchanger 642, such that the stream 602a becomes superheated vapor. Stream 602b is sent to sensible heat exchanger 643, latent heat exchanger 644, and sensible heat exchanger 645, such that the stream 602b becomes superheated vapor. The superheated carboxylic acids 602a and 602b react with olefins 604 in esterification reactor 620. In some embodiments, esterification reactor 620 has its own temperature control system. Esters 605 react with hydrogen in a hydrogenolysis reactor 622 to produce alcohol 606. In some embodiments, hydrogenolysis reactor 622 has its own temperature control system.

Alcohol product stream 606 is split into two streams 606a and 606b. Stream 606a enters expander 646, where the pressure is reduced. The low-pressure alcohol enters dehydration reactor 624. In some embodiments, dehydration reactor 624 has its own temperature control system. Stream 606a exiting dehydration reactor 624 (comprising olefins 606aa and water 606ab) may then be compressed in compressor 647 and enter

sensible heat exchanger **645** and latent heat exchanger **644**, which cools the stream and allows water **606ab** to condense. Olefin **606aa** and the water **606ab** are separated in tank **648**. Olefin **606aa** is heated in sensible heat exchanger **645** so it can enter esterification reactor **620** as part of the olefin **604**. Water **606ab** exiting tank **648** is cooled in sensible heat exchanger **643**. In some embodiments, the water **606ab** may flow through a turbine **649** as part of a high-pressure liquid **606ab'**. The liquid **606ab'** comprises primarily water, but it may also comprise some alcohol because the dehydration reaction in dehydration reactor **624** is reversible. The alcohols in liquid **606ab'** are recovered by distillation in column **650** and are returned to the alcohol stream **606**.

The stream **606b** is sent to the oligomerization reactor **626**. In some embodiments, oligomerization reactor **626** has its own temperature control system. The product exiting oligomerization reactor **626** is cooled through sensible heat exchanger **642**, latent heat exchanger **641**, and sensible heat exchanger **640**. Tank **651** may contain unreacted species (e.g., low-molecular-weight olefins), which may be returned via **607** to oligomerization reactor **626**. In embodiments, stream **606b** may flow through a turbine **652** as part of a high-pressure liquid **606b'** to recover expansion energy. Tank **653** may contain unreacted species, which are compressed using compressor **654** and returned via **606bb** to oligomerization reactor **626**. Hydrocarbons are removed from tank **653** via **608**.

Recycle streams **607** and/or **606bb** may contain non-reactive gases, which may be purged via line **606bb'** to prevent accumulation within the system. The purged gases may be sent to a separator to recover the reactive components, or they may be burned for process heat. Esterification reactor **620**, hydrogenolysis reactor **622**, and/or oligomerization reactor **626** can operate at a higher pressure (~3000 kPa), whereas dehydration reactor **624** can operate at a lower pressure (~20 to 500 kPa), according to certain embodiments. In the illustrated embodiment, expander **646** recovers energy from the pressure reduction and allows it to supplement the energy used by compressor **647**.

As with FIGS. **4** and **5**, FIGS. **8** and **9** show the same configuration as in FIGS. **6** and **7**, but using only one reactor **621** to perform the esterification and hydrogenolysis.

FIG. **10** shows a block diagram of a system **1000** ("Option B") for converting carboxylic acids to hydrocarbons, according to another embodiment. Carboxylic acids **1002** react with olefins **1004** in an esterification reactor **1020** to form esters **1005**. Esters **1005** are hydrogenolyzed to alcohols **1006** in a hydrogenolysis reactor **1022**. The alcohol stream **1006** is sent to an oligomerization reactor **1026**. In some embodiments, oligomerization reactor **1026** operates with a residence time that is short enough to form significant amounts of unreacted intermediates (olefins), which are separated from the final products, hydrocarbons **1008** and water. In the illustrated embodiment, the olefins **1004** are fed back to the esterification reactor **1020**.

FIG. **11** shows a detailed description of Option B, according to another embodiment. Carboxylic acid stream **1002** is sent to sensible heat exchanger **1040**, latent heat exchanger **1041**, and sensible heat exchanger **1042**, such that the carboxylic acid stream **1002** becomes superheated vapor. The superheated carboxylic acids **1002** react with olefins **1004** in the esterification reactor **1020** to produce esters **1005**. In some embodiments, esterification reactor **1020** has its own temperature control system. Esters **1005** are sent to hydrogenolysis reactor **1022** to produce alcohols **1006**. In some embodiments, hydrogenolysis reactor **1022** has its own temperature control system.

Alcohol stream **1006** is sent to oligomerization reactor **1026**. In some embodiments, oligomerization reactor **1026** has its own temperature control system. The product exiting the oligomerization reactor is cooled through sensible heat exchanger **1042**, latent heat exchanger **1041**, and sensible heat exchanger **1040**. In some embodiments, the stream **1006** may flow through a turbine **1052** as part of a high-pressure liquid **1006'** to recover expansion energy. In embodiments, the residence time in oligomerization reactor **1026** is short enough that there is a significant amount of unreacted species (e.g., low-molecular-weight olefins) in the gas space of tank **1051**, which may then be supplied to the esterification reactor **1020**. Similarly, tank **1053** may contain unreacted species **1007**, which may be compressed using compressor **1054** and sent to esterification reactor **1020**. Hydrocarbons **1008** are removed from tank **1053**.

The recycle stream **1007** and/or **1006bb** may contain non-reactive gases, which may be purged **1006bb'** to prevent accumulation within the system. The purged gases may be sent to a separator to recover the reactive components, or they may be burned for process heat. In certain embodiments, esterification reactor **1020**, hydrogenolysis reactor **1022**, and oligomerization reactor **1026** can operate at a higher pressure (3000 kPa).

FIGS. **12** and **13** show the same configurations as in FIGS. **10** and **11** but using only one single reactor **1021** to perform the esterification and hydrogenolysis.

FIG. **14** shows a block diagram of system **1400** ("Option C") for converting carboxylic acids to hydrocarbons, according to another embodiment. Carboxylic acids **1402** react with olefins **1404** in an esterification reactor **1420** to form esters **1405**. The esters **1405** are hydrogenolyzed into alcohols **1406** in a hydrogenolysis reactor **1422**. The alcohol stream **1406** is sent to a dehydration reactor **1424** to produce water and olefins **1404**. The olefins stream **1404** is split in two portions: one stream goes to the esterification reactor **1420**, and the other goes to oligomerization reactor **1426**, which produces hydrocarbons **1408** and water. Because only olefins **1404** are being fed to oligomerization reactor **1426**, no water should be produced during the oligomerization; however, teachings of some embodiments recognize that some alcohol may be expected in the olefin stream going to oligomerization reactor **1426**. In the presence of hydrogen (which remains from the hydrogenolysis) and carbon monoxide (which can be formed in dehydration reactor **1424**), methanol and other alcohols can be formed in oligomerization reactor **1426**; therefore, water may form.

FIG. **15** shows a detailed description of Option C, according to another embodiment. Carboxylic acid stream **1402** is split into two portions, **1402a** and **1402b**. Stream **1402a** is sent to sensible heat exchanger **1440**, latent heat exchanger **1441**, and sensible heat exchanger **1442**, such that stream **1402a** becomes superheated vapor. Stream **1402b** is sent to sensible heat exchanger **1443**, latent heat exchanger **1444**, and sensible heat exchanger **1445**, such that stream **1402b** becomes superheated vapor. The superheated carboxylic acids **1402a** and **1402b** react with olefins **1404** in esterification reactor **1420** to produce esters **1405**. In embodiments, esterification reactor **1420** has its own temperature control system. Esters **1405** are sent to hydrogenolysis reactor **1422** to produce alcohols **1406**. In embodiments, hydrogenolysis reactor **1422** has its own temperature control system.

Alcohol product stream **1406** enters expander **1446**, where the pressure is reduced. The low-pressure alcohols enter dehydration reactor **1424**. In some embodiments, dehydration reactor **1424** has its own temperature control system. The stream **1406** (comprising olefins **1406a** and water **1406b**)

exiting dehydration reactor 1424 is compressed using compressor 1447 and enters sensible heat exchanger 1445 and latent heat exchanger 1444, which cools the stream 1406 and allows water 1406b to condense. Olefins 1406a and water 1406b are separated in tank 1448. Olefins 1406a are re-heated in sensible heat exchanger 1445. Olefin stream 1406a is split into two portions: 1406aa and 1406ab. Stream 1406aa is sent to oligomerization reactor 1426, and stream 1406ab is sent to esterification reactor 1420. Water 1406b exiting tank 1448 is cooled in sensible heat exchanger 1443. In embodiments, water 1406b flows through a turbine 1449 as part of a high-pressure liquid 1406b'. The liquid 1406b' comprises primarily water, but may also comprise some alcohol because the reaction in dehydration reactor 1424 is reversible. The alcohols in liquid 1406b' are recovered by distillation in column 1450 and are returned to alcohol stream 1406.

The product exiting oligomerization reactor 1426 is cooled through sensible heat exchanger 1442, latent heat exchanger 1441, and sensible heat exchanger 1440. In some embodiments, stream 1406aa flows through a turbine 1452 as part of a high-pressure liquid 1406aa' to recovery energy expansion. The gas space in tank 1451 may contain unreacted species (e.g., low-molecular-weight olefins), which are returned to the oligomerization reactor 1426. Similarly, tank 1453 may contain unreacted species, which are compressed using compressor 1454 and returned to oligomerization reactor 1426.

The recycle stream may contain non-reactive gases, which may be purged to prevent accumulation within the system. The purged gases may be sent to a separator to recover the reactive components, or they may be burned for process heat. Esterification reactor 1420, hydrogenolysis reactor 1422, and/or oligomerization reactor 1426 can operate at a higher pressure (~3000 kPa), whereas the dehydration reactor 1424 operates at a lower pressure (~20 to 500 kPa), according to certain embodiments. In the illustrated embodiment, expander 1446 recovers energy from the pressure reduction and allows it to supplement the energy used by compressor 1447.

FIGS. 16 and 17 show the same configuration as in FIGS. 14 and 15 but using a single reactor 1421 to perform the esterification and hydrogenolysis.

FIG. 18 shows a block diagram of a system 1800 ("Option A1") for converting ketones or carboxylic acids directly to hydrocarbons in the oligomerization reactor, according to another embodiment. The ketones or carboxylic acids 1802 feed into an oligomerization reactor 1826. The products that exit oligomerization reactor 1826 may be separated in a tank 1851 into water, hydrocarbons 1808, and gaseous products. In some embodiments, gaseous product may represent 30-40% of the products that exit the oligomerization reactor 1826. The gaseous product may be burned for process heat or reformed into hydrogen in a reformer 1823 using standard technology (e.g., steam reforming, partial oxidation, or other suitable systems and methods). The hydrogen may be used to convert a portion of the ketones or carboxylic acids 1802 into alcohols 1806 in an alcohol reactor 1821; these alcohols 1806 may then be sent to the oligomerization reactor 1826.

If ketones are used as the feed, then hydrogenation may be very direct using appropriate hydrogenation catalyst (e.g., Raney nickel, platinum, copper chromite, or other suitable hydrogenation catalyst). If carboxylic acids are used as the feed, then alcohol production 1821 may include one of the processes described in FIGS. 2 through 5. The details of the process may be similar to those described in FIGS. 3, 5, 7, 9, 11, 13, 15 and 17, which use appropriate sensible and latent heat exchangers to heat and cool the process streams, as well

as compressors and expanders to manipulate the pressure. These details are not repeated.

FIG. 19 shows a block diagram of a system 1900 ("Option B1") for converting ketones or carboxylic acids directly to hydrocarbons in the oligomerization reactor. This embodiment incorporates a separator 1825 (e.g., pressure-swing adsorption, membranes, cryogenic distillation) into Option A1 to recover olefins 1804 from the gaseous stream and return them to oligomerization reactor 1826 rather than sending them to reformer 1823.

FIG. 20 shows a block diagram of a system 2000 ("Option A2") for converting ketones or carboxylic acids directly to hydrocarbons. This embodiment modifies Option A1 by incorporating the alcohol production (e.g., hydrogenation) and oligomerization mechanisms into a single reactor 1827. Teachings of certain embodiments recognize that, because the same catalysts employed for oligomerization are known to effect hydrogenation as well (e.g., U.S. Pat. No. 3,894,107 and Minachev, Kh. M., Garanin, V. I., Kharlamov, V. V., Kapustin, M. A., "Hydrogenation of acetone on cationic forms of zeolites," *Russian Chemical Bulletin* 23(7), 1472-1475 (1974)), the ketones or the carboxylic acids and hydrogen may be fed directly to the same reactor, thus avoiding having a separate hydrogenation reactor and other equipment needed for alcohol generation.

FIG. 21 shows a block diagram of a system 2100 ("Option B2") for converting ketones or carboxylic acids directly to hydrocarbons. This embodiment modifies Option B1 by incorporating the alcohol production (e.g., hydrogenation) and oligomerization mechanisms into a single reactor 1827. Teachings of certain embodiments recognize that, because the same catalysts employed for oligomerization are known to effect hydrogenation as well, the ketones or the carboxylic acids and hydrogen may be fed directly to the same reactor, thus avoiding having a separate hydrogenation reactor and other equipment needed for alcohol generation.

FIG. 22 shows a detailed process flow diagram of a system 2200 for the direct conversion of carboxylic acids or ketones to hydrocarbons using a single reactor for both hydrogenation and oligomerization (based on Option A2 of FIG. 20 and Option B2 of FIG. 21) according to one embodiment. The carboxylic acid or ketone stream 2202 is sent (e.g., via feed pump 2203) to sensible heat exchanger 2240, latent heat exchanger 2241, and sensible heat exchanger 2242, such that the stream 2202 becomes superheated vapor. The superheated carboxylic acids or ketones and hydrogen are sent to the hydrogenation/oligomerization reactor 2227. In some embodiments, hydrogenation/oligomerization reactor 2227 has its own temperature control system. The product exiting hydrogenation/oligomerization reactor 2227 is cooled through sensible heat exchanger 2242, latent heat exchanger 2241, and sensible heat exchanger 2240. In some embodiments, this high pressure liquid flows through a turbine 2252 as part of a high-pressure liquid 2202' to recover expansion energy. There may be unreacted species (e.g., low-molecular-weight olefins) in the gas space of tank 2251, which may be recycled to hydrogenation/oligomerization reactor 2227. Similarly, tank 2253 may contain unreacted species, which may be compressed using compressor 2254 and sent back to the hydrogenation/oligomerization reactor 2227. Hydrocarbons 2208 may be removed from tank 2253.

The recycle stream may contain non-reactive gases, which may be purged to prevent accumulation within the system. The purged gases may be sent to a separator to recover the reactive components, or they may be burned for process heat or reformed into hydrogen. Hydrogenation/oligomerization

19

reactor **2227** may operate at a higher pressure (~3000 kPa), according to certain embodiments.

FIG. **23** shows a block diagram for an embodiment of a system **2300** that directly converts ketones to hydrocarbons, which corresponds to one of the routes shown in FIG. **1A**. In the illustrated embodiment, biomass **2370** is optionally pretreated **2380** to enhance biodegradability using lime (e.g., using, but not limited to, lime pretreatment described in, but not limited to, U.S. Pat. Nos. 5,693,296 and 5,865,898, and U.S. Pat. App. Nos. 60/423,288 and 60/985,059). Then, the pretreated biomass **2370** is directly fermented in the fermenter **2382**, creating carboxylate salts **2372** (e.g., as described in, but not limited to, U.S. Pat. No. 5,962,307 and U.S. patent application Ser. Nos. 11/298,983 and 11/456,653). The resulting carboxylate salts **2372** are dewatered and, as a result, concentrated (e.g., using processes or systems described in, but not limited to, U.S. Pat. Nos. 5,986,133, 7,251,944, and 7,328,591 and U.S. Pat. App. No. 60/985,059) in a concentrator **2384**. The concentrated salts are converted to ketones **2302** (e.g., using processes or systems described in, but not limited to, U.S. Pat. Nos. 6,043,392 and 6,262,313) at ketone reactor **2386**. Ketones **2302** may be directly converted to hydrocarbons **2308** and alcohols **2306** in a manner similar to the processes described in FIGS. **18-22**. However, in the illustrated embodiment, the gases **2329** from oligomerization reactor **2326** are directed to the fermenter **2382**, for example, through tank **2351**. In the fermenter **2382**, biologically reactive species (e.g., hydrogen and carbon monoxide) are converted to carboxylate salts **2372**. Carbon dioxide is removed from the energetic gases (e.g., hydrogen, methane) **2330'** exiting fermenter **2382** in fermenter exit gas **2330** via a separator **2325** using standard methods (e.g., amine adsorption, membranes, cryogenics). Energetic gases **2330'** are sent to a reformer **2323** to produce hydrogen for alcohol reactor **2321**. All or a portion (**2310**) of the water **2331** that exits oligomerization reactor **2326** may be used in the reformer **2323**, for example after separation in tank **2351**.

FIG. **24** shows a block diagram of a system **2400** that directly converts ketones to hydrocarbons, which corresponds to one of the routes shown in FIG. **1A**, according to one embodiment. This embodiment modifies system **2300** by incorporating the alcohol production (e.g., hydrogenation) and oligomerization mechanisms into a single reactor **2327**, with both the ketones and the hydrogen fed to this reactor.

As mentioned and indicated in FIG. **1**, in embodiments, biomass may be converted to hydrocarbons using a calcium-based system. Via this process, ketone production from carboxylate salts is integrated with subsequent conversion of the ketones into alcohols and hydrocarbons. FIG. **25**, a subset of FIG. **1**, is a block diagram showing complete biomass conversion for calcium-based systems, according to an embodiment. The first step in the process is pretreatment (e.g., but not limited to, lime pretreatment). Such lime pretreatment is described, for example, but not limited to, in U.S. Pat. Nos. 5,693,296 and 5,865,898 as well as in U.S. Pat. App. Nos. 60/423,288 and 60/985,059. Such pretreatment is optional if the raw biomass is sufficiently digestible. The digestible biomass is then directly fermented to carboxylate salts. Such fermentation may be performed as described, for example, but not limited to, in U.S. Pat. No. 5,962,307 and U.S. patent application Ser. Nos. 11/298,983 and 11/456,653. From the fermentation, a liquid fermentation broth is obtained, which comprises mostly water and the carboxylate salts. For further treatment, the carboxylate salts may be concentrated, for example, but not limited to, via dewatering **120A** as described in U.S. Pat. Nos. 5,986,133, 7,251,944 and 7,328,591 and U.S. Pat. App. No. 60/985,059. In the case currently being

20

considered, where calcium carboxylate salts have been created, such calcium carboxylate salts may be thermally converted **125A** into ketones. Such thermal conversion may be performed, for example, but not limited to, as described in U.S. Pat. No. 6,262,313. Ketones may also be generated by passing carboxylic acids through a catalytic bed of, for example, zirconium oxide. The resulting ketones may be sent downstream to be processed as described hereinabove with respect to FIGS. **18-24**. Thus, in such embodiments, appropriate downstream processing **140A'** may be performed as described in FIGS. **18-24**.

Ketones produced in a ketone reactor by the dry distillation of carboxylate salts must be removed and cooled down quickly to avoid degradation. Prior art methods utilize a vacuum to reduce residence time in the ketone reactor, requiring vacuum and chilling equipment. For example, in U.S. Pat. No. 6,262,313, carboxylate salts are thermally converted to ketones, by heating under vacuum and subsequent condensation and recovery. As mentioned, the vacuum and condensation help increase yields by quickly removing ketones from the hot reaction zone, thus avoiding degradation, however, avoidance of such vacuum conditions may be more economically desirable.

This same goal to avoid ketone degradation can be accomplished by using a sweep gas, which eliminates the capital associated with maintaining a vacuum and oversizing chillers. In embodiments, a ketone reactor is integrated with downstream unit operations for producing alcohols and hydrocarbons (e.g., as described in FIGS. **18-24**) utilizing a sweep gas. FIG. **26** is a block diagram showing a system **100A''** incorporating the use of sweep gas and the direct introduction of ketone vapors from the ketone reactor to downstream unit operations, according to an embodiment;

As shown in FIG. **26**, costly vacuum and oversized chillers can be avoided by introducing a sweep gas **121**. In this embodiment, calcium carboxylate salts **124** are introduced into ketone reactor **125B** along with sweep gas **121**. Condensing ketones may be avoided if the hot ketone vapors **126A** exiting ketone reactor **125B** are cooled, for example via heat exchanger **127A** to avoid degradation and cooled ketone vapors **126B** are sent to the next unit operation **140'**, as described in FIGS. **18-24** hereinabove. In this manner, ketones produced from dry distillation of carboxylate salts may be directly sent to alcohol or gasoline conversion without the need for condensation, thus saving capital on the downstream condensation, heating, and vaporization equipment. Because sweep gas rapidly removes ketones formed in ketone reactor **125B**, substantial capital savings are expected by eliminating vacuum and chilling equipment needed to remove and condense low-pressure ketones, which were required by the previous vacuum schemes.

It should be noted that the use of the sweep gas and the direct introduction of the ketone vapors from the ketone reactor to the unit operations downstream can be used together or may be employed independently. When the ketone vapors from ketone reactor **125B** are sent directly to downstream conversion **140'**, with or without the aid from a sweep gas, the feed pump **2203**, sensible heat exchanger **2240**, and latent heat exchanger **2241** shown in FIG. **22** may no longer be utilized or needed. Because ketone vapors from ketone reactor **125B** directly react in downstream unit operations **140'**, substantial capital saving may be realized by eliminating the condensing equipment, peripherals, and downstream equipment needed to re-vaporize ketones, which were required by prior art vacuum processes. Reacting ketone vapors directly into hydrocarbon or alcohols may also reduce material losses typical when separate unit operations are employed, such as

21

condensing. In addition, avoiding liquid heating or cooling may allow for higher energy efficiencies.

Other than oxidants (e.g., oxygen), many gases may be employed as sweep gas. If the sweep gas option is practiced and it is desired to condense the ketones, a condensing sweep gas can be employed, to minimize/avoid the loss of ketones vapors that may occur with a non-condensing sweep gas, such as nitrogen. An example of such a condensing sweep gas is steam. Simulations with HYSYS suggest that virtually no ketones are lost when steam is used as the sweep gas. Steam has the added advantage that, when hydrocarbons are the final product, when the steam condenses, it is immiscible with hydrocarbons and is easily separated therefrom.

As mentioned, the sweep gas may be any gas other than oxidants (e.g., oxygen), but the use of hydrogen may be desired in instances where hydrogen is used downstream to hydrogenate some or all the ketones. Thus, when producing alcohols or hydrocarbons, hydrogen is a desirable sweep gas because it is also a reactant. To maintain a low partial pressure of ketones in the ketone reactor **125B**, it may be desirable to recycle substantial quantities of hydrogen. In such embodiments, gas **122** from downstream processing **140A'** may be recycled to ketone reactor **125B**. The recycle gas **122** may be passed through countercurrent heat exchanger **127B** for recycle to ketone reactor **125B**.

The literature describes the use of nitrogen sweep gas (Ardagh, E. G. R., Barbour, A. D., McClellan, G. E., and McBride, E. W. (1924). Distillation of acetate of lime, *Industrial and Engineering Chemistry*, 16, 1133-1139). However, nitrogen is both inert and noncondensable. According to this disclosure, a reactive (e.g., hydrogen) or condensable (e.g., steam) sweep gas is utilized.

When sweep gas is employed, an important consideration is whether hydrocarbon conversion occurs at the same pressure as the ketone reactor, i.e., pressures from vacuum to 1 atm. Experiments have shown that hydrocarbon conversion of ketones and secondary alcohols over H-ZSM-5 zeolite is feasible at 1 atm. In such case, vapors are sent directly to the downstream unit operation after sufficient cooling and heating. If, however, the pressure desired in downstream processing **140A'** is higher, a compressor **128** may be used. If sweep gas is being recycled, an expander **129** and/or a countercurrent heat exchanger **127B** may be used, for example, to improve energy efficiency.

If the pressure and temperature of the ketone conversion and hydrocarbon conversion reactions are similar, a simpler method may be implemented. In this case, the catalyst can be placed in the exhaust ports of ketone reactor **125B** so that the ketones react when exiting ketone reactor **125B**.

In some of these embodiments and some downstream unit operations for converting ketones into hydrocarbons, a dual-catalyst bed can be employed, where a hydrogenation catalyst (e.g., copper chromite) is loaded in the first part of the reactor, followed by the dehydration/oligomerization catalyst (e.g., H-ZSM-5 zeolite). This dual-catalyst bed may serve to allow conversion of all or most of the ketones to alcohols, thus increasing yields and allowing for production of more desirable hydrocarbons. A dual-catalyst bed can thus be employed where a hydrogenation catalyst is first used that converts all or part of the ketones to alcohols, and is followed by a dehydration/oligomerization catalyst that converts the alcohols and/or ketones to hydrocarbons. Alternatively, a zeolite catalyst can be modified to incorporate hydrogenation catalyst (e.g., platinum) directly in its pores. Employing two different catalysts in the same bed may reduce capital equipment costs and, by combining two reactions into one reactor, may also minimize material losses.

22

In many cases, the hydrocarbon products exiting the oligomerization reactor contain significant quantities of olefins. In embodiments, these condensed products, which are substantially free of water, are sent to another oligomerization reactor (or recycled to the oligomerization reactor) thereby increasing the chain length of the final hydrocarbon product.

FIG. **27** shows a block diagram of a system **2500** that directly converts carboxylic acids to hydrocarbons, which corresponds to one of the routes shown in FIGS. **1A** and **1B**, according to one embodiment. This embodiment modifies system **2300** of FIG. **23** by converting carboxylic acids **2302** (instead of ketones) directly into hydrocarbons **2308**. The process steps are similar to those described in system **2300**, except that the carboxylate salts are converted to carboxylic acids (e.g., via "acid springing," described in, but not limited to, U.S. Pat. No. 6,395,926 or U.S. patent application Ser. No. 11/456,653) using an acid recovery system **2388**.

FIG. **28** shows a block diagram of a system **2600** that directly converts carboxylic acids to hydrocarbons, which corresponds to one of the routes shown in FIGS. **1A** and **1B**, according to one embodiment. This embodiment modifies system **2500** of FIG. **27** by incorporating the alcohol production (e.g., hydrogenation) and oligomerization mechanisms into a single reactor **2327**, with both the carboxylic acids and the hydrogen being fed to this reactor.

FIG. **29** shows a block diagram of a system **2700** for direct conversion of ammonium carboxylate salts to hydrocarbons according to an embodiment. The embodiment modifies Option A1 of FIG. **18** by feeding ammonium carboxylate salts **2702** (solids, as a slurry and/or in solution) to the system **2700**. Ammonium carboxylate salts **2702** are volatile salts, which when completely vaporized are decomposed into ammonia and carboxylic acids. Some other products, such as amides, might also form. In FIG. **29**, a portion of the ammonium carboxylate salts **2702** may be sent to an alcohol reactor **2721**, which converts the ammonium carboxylate salts **2702** into alcohols **2706**. Teachings of certain embodiments recognize that converting some of the ammonium carboxylate salts **2702** may allow the system **2700** to take advantage of available hydrogen from reformer **2723**. Such conversion to alcohols can be done, for example, by using the process described in, but not limited to, U.S. patent application Ser. No. 11/456,653; in another embodiment, they may be converted to carboxylic acids first (e.g., as described in, but not limited to, patent application Ser. No. 11/456,653) and then converted to alcohols (e.g., as described in FIGS. **2-5**). The details of the process are similar to those described in FIGS. **3, 5, 7, 9, 11, 13, 15** and **17**, which used appropriate sensible and latent heat exchangers to heat and cool the process streams, as well as compressors and expanders to manipulate the pressure. These details are not repeated.

After the ammonium carboxylate salts are vaporized and enter oligomerization reactor **2726**, only the carboxylic acid is converted into hydrocarbons **2708**. The ammonia **2709** passes unreacted. Such observation was seen by Butter et al. (U.S. Pat. No. 3,894,107), who passed nitrogen-containing compounds through an H-ZSM-5 zeolite catalyst and obtained hydrocarbons and unreacted ammonia as products. Under certain conditions, such as those demonstrated in some of the examples accompanying FIGS. **43-50**, ammonia may react to form other valuable compounds, such as acetonitrile.

In system **2700**, ammonia **2709** is to be recovered from the products. First, some of the ammonia **2709** will go into solution in the water generated; therefore, a separator **2756** (e.g., a flash tank) may be employed to separate the water **2710** from ammonia **2709**. In addition, some ammonia may end up in the gases that exit oligomerization reactor **2726**. To remove

the ammonia from the gas stream, an ammonia separator **2755** may be employed. For example, a bed packed with solid acid absorbent that will bind the ammonia reversibly, followed by desorption of the ammonia once the bed is saturated (by having two or more of these units operating in parallel, the process can swing from the absorption cycle to the desorption cycle thus continuously removing the ammonia from the stream). The ammonia-free gases **2757** can then be sent to be burned for process heat and/or they may be sent to the reformer **2723** to produce hydrogen, as shown in FIG. **29**. The hydrogen produced may be employed in the alcohol reactor **2721**. In embodiments, ammonia **2709** is also released and recovered in alcohol production unit **2721**.

FIG. **30** shows a block diagram of a system **2800** for converting ammonium carboxylate salts directly to hydrocarbons in the oligomerization reactor. The embodiment modifies Option B1 of FIG. **19** by feeding ammonium carboxylate salts **2802** to the system **2800**, as well as incorporates a separator **2825** (e.g., pressure-swing adsorption, membranes, cryogenic distillation) into the system **2700** of FIG. **29** to recover olefins **2804** from the gaseous stream and return them to oligomerization reactor **2826** rather than sending them to reformer **2823**.

FIG. **31** shows a block diagram of a system **2900** for converting ammonium carboxylate salts directly to hydrocarbons. The embodiment modifies Option A2 of FIG. **20** by feeding ammonium carboxylate salts **2902** to system **2900**, as well as incorporates the oligomerization and hydrogenation processes of system **2700** into a single reactor **2927**. Teachings of certain embodiments recognize that, because the same catalysts employed for oligomerization are known to effect hydrogenation as well (e.g., U.S. Pat. No. 3,894,107, Minachev, Kh. M., Garanin, V. I., Kharlamov, V. V., Kapustin, M. A., "Hydrogenation of acetone on cationic forms of zeolites," *Russian Chemical Bulletin* 23(7), 1472-1475 (1974), ammonium carboxylate salts and hydrogen may be fed directly to the same reactor, thus avoiding the need for a separate hydrogenation reactor and other equipment used for alcohol generation.

FIG. **32** shows a block diagram of a system **3000** for converting ammonium carboxylate salts directly to hydrocarbons. The embodiment modifies Option B2 of FIG. **21** by feeding ammonium carboxylate salts **3002** to system **3000**, as well as incorporates the oligomerization and hydrogenation processes of system **2800** into a single reactor **3027**. Teachings of certain embodiments recognize that, because the same catalysts employed for oligomerization are known to effect hydrogenation as well, the carboxylate salts and hydrogen may be fed directly to the same reactor, thus avoiding the need for a separate hydrogenation reactor and other equipment used for alcohol generation.

FIG. **33** shows a detailed process flow diagram of a system **3100** for the direct conversion of ammonium carboxylate salts (solid, as a slurry and/or in solution) to hydrocarbons using a single reactor for both hydrogenation and oligomerization (based on Options A2 and B2 illustrated in FIGS. **31** and **32**) according to one embodiment. The ammonium carboxylate stream **3102** is sent to sensible heat exchanger **3140**, latent heat exchanger **3141**, and sensible heat exchanger **3142**, such that the stream **3102** becomes superheated vapor. This superheated stream and hydrogen are sent to hydrogenation/oligomerization reactor **3127**. In some embodiments, hydrogenation/oligomerization reactor **3127** has its own temperature control system. The product exiting hydrogenation/oligomerization reactor **3127** is cooled through sensible heat exchanger **3142**, latent heat exchanger **3141**, and sensible heat exchanger **3140**. In some embodiments, this high pressure liquid flows through a turbine **3152** as part of a high-pressure liquid **3102'** to recover expansion

energy. There may be unreacted species (e.g., low-molecular-weight olefins) in the gas space of tank **3151**, which may be then recycled to hydrogenation/oligomerization reactor **3127**. Similarly, tank **3153** may contain unreacted species, which may be compressed using compressor **3154** and sent back to hydrogenation/oligomerization reactor **3127**.

The recycle stream may contain non-reactive gases, which may be purged to prevent accumulation within the system. The purged gases may be sent to a separator to recover the reactive components, or they may be burned for process heat or reformed into hydrogen. Hydrogenation/oligomerization reactor **3127** can operate at a higher pressure (~3000 kPa), according to certain embodiments.

Before the gas stream from tanks **3151** and **3153** is returned to hydrogenation/oligomerization reactor **3127**, or before some of it is purged, ammonia **3109** may be removed therefrom by passing it through an ammonia separator **3155**. For example, a bed packed with solid acid absorbent that will reversibly bind the ammonia may be employed, followed by desorption of the ammonia once the bed is saturated; in some embodiments, by having two or more of these units operating in parallel, the process can swing from the absorption cycle to the desorption cycle, thus continuously removing the ammonia from the stream. In addition, the water **3110** that is separated from the hydrocarbon **3108** and gas stream in tank **3153** may contain some ammonia, which is separated from the water, for example, by increasing its temperature using steam in sensible heat exchanger **3157** and then sending the stream to tank **3156** (e.g., flash tank), allowing ammonia **3109** to be recovered in the vapor phase, while ammonia-free water is recovered in the liquid phase. Alternatively, a steam stripper can also be used to strip the ammonia from the water.

FIG. **34** shows a block diagram of an embodiment of a system **3200** for a process that directly converts ammonium carboxylate salts to hydrocarbons, which corresponds to one of the routes shown in FIG. **1B**. In the illustrated embodiment, the biomass **3270** is optionally pretreated at **3280** to enhance biodegradability (e.g., using, but not limited to, lime pretreatment described in, but not limited to, U.S. Pat. Nos. 5,693,296 and 5,865,898, and U.S. Pat. App. Nos. 60/423,288 and 60/985,059). Subsequently, the pretreated biomass **3270** is directly fermented at **3282** to ammonium carboxylate salts **3202** (e.g., as described in, but not limited to, U.S. patent application Ser. Nos. 11/298,983 and 11/456,653). The resulting ammonium carboxylate salts **3202** are dewatered at a dewatering unit **3284**. As a result, the carboxylate salts **3202** are concentrated (e.g., using processes or systems described in, but not limited to, U.S. Pat. Nos. 5,986,133, 7,251,944, and 7,328,591 and U.S. Pat. App. No. 60/985,059). The ammonium carboxylate salts **3202** may be directly converted to hydrocarbons **3208** and alcohols **3206**, in a manner similar to the processes described in FIGS. **29-33**. However, in this embodiment, the gases **3229** exiting oligomerization reactor **3226** are directed to the fermenter **3282**, after separation from hydrocarbons **3208** and water **3231** in tank **3251**. In fermenter **3282**, biologically reactive species (e.g., hydrogen and carbon monoxide) and buffering species (e.g., the ammonia) are converted to ammonium carboxylate salts **3202**. Energetic gases **3230'** (e.g., hydrogen and/or methane) exiting fermenter **3282** are separated from carbon dioxide in fermenter exit gas **3230** using standard methods (e.g., amine adsorption, membranes, cryogenics). Energetic gases **3230'** are sent to a reformer **3223** to produce hydrogen for alcohol producer **3221**. Ammonia **3209** recovered from the water exiting the oligomerization reaction **3226** (e.g., using a tank **3256**) and from alcohol producer **3221** is sent back to the fermenter **3282**, via a packed bed **3258** wherein it is contacted with carbon dioxide from separator **3225**. This produces ammonium bicarbonate, which allows easier pH control in fermenter **3282**. Shown in dotted lines, it might be desired to

25

remove the ammonia present in the gas stream 3229 that is generated from the oligomerization reactor 3226 (e.g., to allow better pH control in the fermentation); thus, an ammonia separator 3255 (e.g., beds packed with a solid acid absorbent) may be employed. The ammonia 3209' recovered from this gas joins the ammonia 3209 from the water 3231 that exits oligomerization reactor 3255 and the ammonia 3209" from alcohol reactor 3221 and is sent to packed bed 3258' to be converted into ammonium bicarbonate to control the pH in the fermentation. Water 3210 that exits oligomerization reactor 3226 may be used in reformer 3223 after ammonia 3209 has been removed therefrom.

FIG. 35 shows a system 3300 that directly converts ammonium carboxylate salts to hydrocarbons, which corresponds to one of the routes shown in FIG. 1B, according to one embodiment. This embodiment modifies system 3200 by incorporating the alcohol production (e.g., hydrogenation) and oligomerization mechanisms into a single reactor 3327, with both the ammonium carboxylate salts and the hydrogen being fed to this reactor.

FIGS. 36 through 42 show systems 3400-4000 for direct conversion of ammonium carboxylate salts to hydrocarbons according to several embodiments. Systems 3400-4000 modify the systems 2700-3300 of FIGS. 29-35 by removing and recovering the ammonia from the ammonium carboxylate stream prior to entering the oligomerization unit. To remove the ammonia from the gas stream, an ammonia separator 3455/3555/3655/3755/3855/3955/4055 may be employed. For example, a bed packed with solid-acid absorbent may be used to bind the ammonia reversibly. Then, once the bed is saturated, the ammonia is desorbed. In some embodiments, by having two or more of these units operating in parallel, the process can swing from the absorption to the desorption cycle, thus continuously removing the ammonia from the stream.

Esterification, hydrogenolysis, and oligomerization reactions are exothermic; therefore, it is possible that some trim cooling might be utilized in some or all of the above configurations. In all cases, in a given reactor, it is possible that the reaction will be incomplete or that byproducts will be produced. In these cases, unreacted reactant or byproducts can be separated and further processed.

Features. Certain embodiments may include, some, none, or all of the following features. The reaction of an olefin with a carboxylic acid to form an ester is irreversible, so the reaction goes to high conversions easily. In contrast, the reaction of a carboxylic acid with an alcohol to form an ester (the more standard technology) is reversible. It requires that the ester products be removed during the reaction to drive the reaction to completion, which is difficult.

The alcohol dehydration reaction is reversible, but it is made more favorable by operating at low pressures. Pressure reduction is accomplished with an expander, which recovers energy for use during the recompression of the gases exiting the dehydration reactor.

The capability of the esterification catalyst to also hydrogenolyze the esters formed from the reaction of the olefin and carboxylic acids avoids expenditures for the implementation of a separate unit for hydrogenolysis, as the carboxylic acids, the olefin and the hydrogen may be fed directly into the same reactor to produce alcohols.

The direct conversion of ketones or carboxylic acids or ammonium carboxylate salts to hydrocarbons (FIGS. 18-24 and 27-35) reduces hydrogen requirements compared to the conversion of ketones, carboxylic acids or ammonium carboxylate salts to alcohols first and then to hydrocarbons (FIGS. 6-17). Combining both of these steps together (direct ketone/carboxylic acid/ammonium carboxylate conversion plus alcohol conversion) allows the process to be "tuned" to match the availability of hydrogen. If hydrogen is readily

26

available, then the alcohol route is favored. If hydrogen is scarce, then the direct ketone/carboxylic acid/ammonium carboxylate route is favored.

The capability of oligomerization catalysts to also hydrogenate the feed avoids expenditures for the implementation of a separate unit for producing alcohols, as the ketones, carboxylic acids and/or the ammonium carboxylate salts may be fed directly with the available hydrogen into the same reactor to produce hydrocarbons.

The processes that integrate with the fermentation (FIGS. 24 and 27-28 and FIGS. 34-35) reduce loads on separators and reformers because biologically reactive gases and ammonia are converted to carboxylate salts and do not have to be separated prior to being sent to the reformer or converted to hydrogen in the reformer.

EXAMPLES

The following section provides further details regarding examples of various embodiments.

Example 1

Isopropanol to Hydrocarbons (Si/Al 30)

Materials and Methods: Liquid isopropanol was vaporized and added to the reactor operated using the conditions shown in Table 1.1. The product exiting the reactor was separated into two fractions: liquid and gas. The total mass of each product was measured and the composition was determined by gas chromatography/mass spectroscopy (GC/MS).

Results: Table 1.2 shows the product distribution. Of the total product, the liquid fraction (gasoline) was 68.89% and the gases were 31.13%. Table 1.3 shows the classes of products in the liquid fraction.

TABLE 1.1

Example 1 Reaction Conditions- Isopropanol-to-Hydrocarbon Reactor	
Isopropanol Flow Rate	10 mL liquid/h
Catalyst Mass	6 g
Weight Hourly Space Velocity (WHSV)	1.31 g reactant/(g catalyst · h)
Temperature (Max.)	325° C.
Pressure	1 atm (abs)
Catalyst	H-ZSM-5 (Si/Al 30)

TABLE 1.2

Product Distribution (wt %)				
	Gas		Liquid	
	CH ₄	0.00%	C5s	13.45%
	CO ₂	0.03%	C6s	11.28%
	C ₂ H ₄	0.52%	C7s	8.99%
	C ₂ H ₆	0.03%	C8s	18.43%
	C ₃ H ₆	1.10%	C9s	10.64%
	C ₃ H ₈	7.13%	C10s	3.95%
	CO	0.00%	C11+	2.13%
	C4s	22.33%	Total	68.87%
	Total	31.13%		

27

TABLE 1.3

Hydrocarbon Distribution in the Liquid (Gasoline) Fraction (wt %)					
Paraffins	Olefins	Isomeric Compounds	Naphthenes	Naphthene Olefinics	Aromatics
4.502	4.601	17.872	27.679	3.91	39.234

Example 2

Isopropanol to Hydrocarbons (Si/Al 280)

Materials and Methods: Liquid isopropanol was vaporized and added to the reactor operated using the conditions shown in Table 2.1. The product exiting the reactor was separated into two fractions: liquid and gas. The total mass of each product was measured and the composition was determined by gas chromatography/mass spectroscopy (GC/MS).

Results: Table 2.2 shows the product distribution. Of the total product, the liquid fraction (gasoline) was 63.23% and the gases were 36.77%. Table 2.3 shows the classes of products in the liquid fraction. Tables 1.3 and 2.3 report identical conditions, except for the catalyst (H-ZSM-5 Si/Al 280 versus Si/Al 30). The product distribution is similar; however, Si/Al 280 has less coking and more paraffins in the product, which is important for a good fuel. FIG. 43 illustrates the liquid-phase product distribution as a function of hydrocarbon type and number of carbons for isopropanol oligomerization over H-ZSM-5 zeolite (Si/Al ratio 280).

TABLE 2.1

Example 2 Reaction Conditions- Isopropanol-to-Hydrocarbon Reactor	
Isopropanol Flow Rate	10 mL liquid/h
Catalyst Mass	6 g
Weight Hourly Space Velocity (WHSV)	1.31 g reactant/(g catalyst · h)
Temperature (Max.)	330° C.
Pressure	1 atm (abs)
Catalyst	H-ZSM-5 (Si/Al 280)

TABLE 2.2

Product Distribution (wt %)			
Gas		Liquid	
CH ₄	0.00%	C5s	13.17%
CO ₂	0.00%	C6s	16.01%
C ₂ H ₄	1.09%	C7s	6.98%
C ₂ H ₆	0.00%	C8s	14.95%
C ₃ H ₆	3.13%	C9s	6.36%
C ₃ H ₈	6.50%	C10s	4.46%
CO	0.33%	C11+	1.30%
C4s	25.72%	Total	63.23%
Total	36.77%		

28

TABLE 2.3

Hydrocarbon Distribution in the Liquid (Gasoline) Fraction (wt %)					
Paraffins	Olefins	Isomeric Compounds	Naphthenes	Naphthene Olefinics	Aromatics
7.869	4.661	15.215	15.037	1.472	49.349

Example 3

Acetone to Hydrocarbons (Si/Al 30)

Materials and Methods: Liquid acetone was vaporized and added to the reactor operated using the conditions shown in Table 3.1. The product exiting the reactor was separated into two fractions: liquid and gas. The total mass of each product was measured and the composition was determined by gas chromatography/mass spectroscopy (GC/MS).

Results: Table 3.2 shows the product distribution. Of the total product, the liquid fraction (gasoline) was 67.16% and the gases were 32.86%. Table 3.3 shows the classes of products in the liquid fraction. FIG. 44 illustrates the liquid-phase product distribution as a function of hydrocarbon type and number of carbons for acetone oligomerization over H-ZSM-5 zeolite (Si/Al ratio 30). Under these conditions, the reaction did not quite go to completion; however, other conditions have shown near-complete conversion is possible (see Example 5).

TABLE 3.1

Example 3 Reaction Conditions- Acetone-to-Hydrocarbon Reactor	
Acetone Flow Rate	10 mL liquid/h
Catalyst Mass	6 g
Weight Hourly Space Velocity (WHSV)	1.31 g reactant/(g catalyst · h)
Pressure	1 atm (abs)
Temperature (Max.)	330° C.
Catalyst	H-ZSM-5 (Si/Al 30)

TABLE 3.2

Product Distribution (wt %)			
Gas		Liquid	
CH ₄	0.22%	C5s	0.92%
CO ₂	1.62%	Acetone	8.06%
C ₂ H ₄	2.76%	C6s	8.58%
C ₂ H ₆	0.04%	C7s	6.52%
C ₃ H ₆	1.19%	C8s	18.13%
C ₃ H ₈	1.40%	C9s	14.01%
CO	0.43%	C10s	6.41%
C4s	25.20%	C11+	4.53%
Total	32.86%	Total	67.16%

TABLE 3.3

Hydrocarbon Distribution in the Liquid (Gasoline) Fraction (wt %)							
Paraffins	Oxygenates	Olefins	Isomeric compounds	Naphthenes	Naphthene Olefinics	Aromatics	Unknown
0	9.351	9.428	2.971	1.88	4.769	54.912	5.033

Acetone to Hydrocarbons (Si/Al 280)

Materials and Methods: Liquid acetone was vaporized and added to the reactor operated using the conditions shown in Table 4.1. The product exiting the reactor was separated into two fractions: liquid and gas. The total mass of each product was measured and the composition was determined by gas chromatography/mass spectroscopy (GC/MS).

Results: Table 4.2 shows the product distribution. Of the total product, the liquid fraction (gasoline) was 74.03% and the gases were 25.97%. Table 4.3 shows the classes of products in the liquid fraction. Tables 3.3 and 4.3 report identical conditions, except for the catalyst. The Si/Al 30 catalyst is more acidic than the Si/Al 280 catalyst. The Si/Al 280 catalyst produced more oxygenates and naphthenes, and less aromatics. FIG. 45 illustrates the liquid-phase product distribution as a function of hydrocarbon type and number of carbons for acetone oligomerization over H-ZSM-5 zeolite (Si/Al ratio 280). Under these conditions, the reaction did not quite go to completion; however, other conditions have shown near-complete conversion is possible (see Example 5).

TABLE 4.1

Example 4 Reaction Conditions- Acetone-to-Hydrocarbon Reactor	
Acetone Flow Rate	10 mL liquid/h
Catalyst Mass	6 g
Weight Hourly Space Velocity (WHSV)	1.31 g reactant/(g catalyst · h)
Pressure	1 atm (abs)
Temperature (Max.)	330° C.
Catalyst	H-ZSM-5 (Si/Al 280)

TABLE 4.2

Product Distribution (wt %)			
Gas		Liquid	
CH ₄	0.15%	C5s	0.40%
CO ₂	0.74%	Acetone	23.33%
C ₂ H ₄	1.19%	C6s	11.54%
C ₂ H ₆	0.00%	C7s	5.95%
C ₃ H ₆	2.27%	C8s	8.16%
C ₃ H ₈	0.31%	C9s	13.88%
CO	0.05%	C10s	6.85%
C4s	21.26%	C11+	3.92%
Total	25.97	Total	74.03%

TABLE 4.3

Hydrocarbon Distribution in the Liquid (Gasoline) Fraction (wt %)							
Paraffins	Oxygenates	Olefins	Isomeric		Naphthene		Unknown
			Compounds	Naphthenes	Olefinics	Aromatics	
0	15.894	9.374	1.01	17.865	3.862	41.26	2.942

Acetone to Hydrocarbons (Si/Al 280)

Materials and Methods: Liquid acetone was vaporized and added to the reactor operated using the conditions shown in Table 5.1. The product exiting the reactor was separated into two fractions: liquid and gas. The total mass of each product was measured and the composition was determined by gas chromatography/mass spectroscopy (GC/MS).

Results: Table 5.2 shows the product distribution. Of the total product, the liquid fraction (gasoline) was 86.16% and the gases were 13.82%. Table 5.3 shows the classes of products in the liquid fraction. Tables 4.3 and 5.3 report identical conditions, except for temperature. The higher temperature reduces the oxygenates and naphthenes, and increases the aromatics. FIG. 46 illustrates the liquid-phase product distribution as a function of hydrocarbon type and number of carbons for acetone oligomerization over H-ZSM-5 zeolite (Si/Al ratio 280). In this example, the reaction went nearly to completion.

TABLE 5.1

Example 5 Reaction Conditions- Acetone-to-Hydrocarbon Reactor	
Acetone Flow Rate	10 mL liquid/h
Catalyst Mass	6 g
Weight Hourly Space Velocity (WHSV)	1.31 g reactant/(g catalyst · h)
Pressure	1 atm (abs)
Temperature (Max.)	400° C.
Catalyst	H-ZSM-5 (Si/Al 280)

TABLE 5.2

Product Distribution (wt %)			
Gas		Liquid	
CH ₄	0.11%	C5s	1.39%
CO ₂	1.63%	Acetone	0.72%
C ₂ H ₄	1.49%	C6s	8.94%
C ₂ H ₆	0.00%	C7s	13.92%
C ₃ H ₆	1.63%	C8s	30.54%
C ₃ H ₈	1.00%	C9s	17.18%
CO	0.28%	C10s	9.29%
C4s	7.68%	C11+	4.18%
Total	13.82	Total	86.16%

TABLE 5.3

Hydrocarbon Distribution in the Liquid (Gasoline) Fraction (wt %)							
Paraffins	Oxygenates	Olefins	Isomeric Compounds	Naphthenes	Naphthene Olefinics	Aromatics	Unknown
0.548	4.583	2.26	1.083	3.772	4.359	68.983	1.255

Example 6

10

Example 7

Acetone and Hydrogen to Hydrocarbons (Si/Al 280)

Materials and Methods: Hydrogen and vaporized acetone were added to the reactor operated using the conditions shown in Table 6.1. The product exiting the reactor was separated into two fractions: liquid and gas. The total mass of each product was measured and the composition was determined by gas chromatography/mass spectroscopy (GC/MS).

Results: Table 6.2 shows the product distribution. Of the total product, the liquid fraction (gasoline) was 80.63% and the gases were 19.38%. The per-pass hydrogen conversion was 44.25%. Table 6.3 shows the classes of products in the liquid fraction. Tables 5.3 and 6.3 report identical conditions, except for the presence of hydrogen, which increases aromatics. FIG. 47 illustrates the liquid-phase product distribution as a function of hydrocarbon type and number of carbons for acetone and hydrogen oligomerization over H-ZSM-5 zeolite (Si/Al ratio 280). In this example, the reaction went nearly to completion.

TABLE 6.1

Example 6 Reaction Conditions- Acetone-plus-Hydrogen-to-Hydrocarbon Reactor	
Acetone Flow Rate	10 mL liquid/h 0.13 mol/h
Water Flow	0
Hydrogen	53 mL/min 0.13 mol/h
Ratio H ₂ /Acetone	1 molar ratio
Pressure	1 atm (abs)
Temperature (Max.)	400° C.
Catalyst	H-ZSM-5 (Si/Al 280)

TABLE 6.2

Product Distribution (wt %)			
Gas		Liquid	
CH ₄	0.14%	C5s	0.84%
CO ₂	2.72%	Acetone	4.05%
C ₂ H ₄	2.31%	C6s	11.54%
C ₂ H ₆	0.00%	C7s	15.81%
C ₃ H ₆	2.56%	C8s	18.71%
C ₃ H ₈	1.00%	C9s	11.39%
CO	0.41%	C10s	9.79%
C4s	10.24%	C11+	8.50%
Total	19.38%	Total	80.63%

TABLE 6.3

Hydrocarbon Distribution in the Liquid (Gasoline) Fraction (wt %)							
Paraffins	Oxygenates	Olefins	Isomeric Compounds	Naphthenes	Naphthene Olefinics	Aromatics	Unknown
0	8.688	3.103	0.295	4.853	3.209	77.83	1.582

Acetic Acid To Hydrocarbons (Si/Al 280)

Materials and Methods: Liquid acetic acid was vaporized and added to the reactor operated using the conditions shown in Table 7.1. The product exiting the reactor was separated into two fractions: liquid and gas. The total mass of each product was measured and the composition was determined by gas chromatography/mass spectroscopy (GC/MS).

Results: Table 7.2 shows the product distribution. Of the total product, the liquid fraction was 49.77% and the gases were 51.76%. FIG. 48 illustrates the liquid-phase product distribution as a function of hydrocarbon type and number of carbons for acetic acid oligomerization over H-ZSM-5 zeolite (Si/Al ratio 280).

TABLE 7.1

Example 7 Reaction Conditions- Acetic-Acid-to-Hydrocarbon Reactor	
Acetic Acid Flow Rate	10 mL liquid/h
Catalyst Mass	6 g
Weight Hourly Space	1.31 g reactant/(g catalyst · h)
Velocity (WHSV)	
Pressure	1 atm (abs)
Temperature (Max.)	400° C.
Catalyst	H-ZSM-5 (Si/Al 280)

TABLE 7.2

Product Distribution (wt %)			
Gas		Liquid	
CH ₄	0.13%	Acetic acid	29.53%
CO ₂	33.99%	2-Propanone	8.195%
C ₂ H ₄	0.23%	Other Oxygenates	4.02%
C ₂ H ₆	0.00%	Aromatics	8.025%
O ₂	0.00%	Total	49.77%
N ₂	0.00%		
H ₂ O	0.00%		
C ₃ H ₆	0.66%		
C ₃ H ₈	0.00%		
CO	0.66%		
C4s	16.09%		
Total	51.76%		

33

Example 8

Acetic Acid and Hydrogen to Hydrocarbons (Si/Al 280)

Materials and Methods: Hydrogen and vaporized acetic acid were added to the reactor operated using the conditions shown in Table 8.1. The product exiting the reactor was separated into two fractions: liquid and gas. The total mass of each product was measured and the composition was determined by gas chromatography/mass spectroscopy (GC/MS).

Results: Table 8.2 shows the product distribution. Of the total product, the liquid fraction was 47.59% and the gases were 52.34%. The hydrogen conversion was 19.17%. FIG. 49 illustrates the liquid-phase distribution for acetic acid and hydrogen oligomerization over H-ZSM-5 zeolite (Si/Al ratio 280). In this example, a substantial portion of the acetic acid was unreacted, so a longer residence time is needed.

TABLE 8.1

Example 8 Reaction Conditions- Acetic-Acid-plus-Hydrogen-to-Hydrocarbon Reactor	
Acetic Acid Flow Rate	10 mL liquid/h
Hydrogen Flow Rate	36 cm ³ /min
Ratio Acid/H ₂	2 molar ratio
Catalyst Mass	6 g
Temperature (Max.)	410° C.
Pressure	1 atm (abs)
Catalyst	H-ZSM-5 (Si/Al 280)

TABLE 8.2

Product distribution (wt %)			
Gas		Liquid	
CH ₄	0.24%	Acetic Acid	40.48%
CO ₂	30.52%	2-Propanone	4.90%
C ₂ H ₄	0.00%	Other Oxygenates	0.90%
C ₂ H ₆	0.00%	Aromatics	1.31%
C ₃ H ₆	3.17%	Total	47.59
C ₃ H ₈	0.00%		
CO	0.37%		
Isobutane	0.00%		
Butane	18.04%		
Isobutylene	0.00%		
1-Butene	0.00%		
Total	52.34		

Example 9

Ammonium Acetate to Hydrocarbons (Si/Al 280)

Materials and Methods: An aqueous solution of 20% ammonium was vaporized and added to the reactor operated using the conditions shown in Table 9.1. The product exiting the reactor was separated into two fractions: liquid and gas. The total mass of each product was measured and the composition was determined by gas chromatography/mass spectroscopy (GC/MS).

Results: Table 9.2 shows the dominant liquid-phase products. FIG. 50 illustrates the liquid-phase distribution as for ammonium acetate oligomerization over H-ZSM-5 zeolite (Si/Al ratio 280). The aromatics are molecules with 8 and 12 carbons.

34

TABLE 9.1

Example 9 Reaction Conditions- Ammonium-Acetate-to-Hydrocarbon Reactor		
5	Ammonium Acetate Solution	50 mL/h
	Ammonium Acetate Concentration	20% (w/w)
	Ammonium Acetate Addition Rate	10 g/h
10	Catalyst Mass	6 g
	Weight Hourly Space Velocity (WHSV)	1.66 g reactant/(g catalyst · h)
	Temperature (Max.)	400° C.
	Pressure	1 atm (abs)
	Catalyst	H-ZSM-5 (Si/Al 280)

TABLE 9.2

Dominant Compounds in Liquid Phase		
20	Acetonitrile	42.70
	Acetic acid	21.29
	Acetone	16.80
	Total	80.79

While preferred embodiments of the invention have been shown and described, modifications thereof can be made by one skilled in the art without departing from the spirit and teachings of the invention. The embodiments described herein are exemplary only, and are not intended to be limiting. Many variations and modifications of the invention disclosed herein are possible and are within the scope of the invention. Where numerical ranges or limitations are expressly stated, such express ranges or limitations should be understood to include iterative ranges or limitations of like magnitude falling within the expressly stated ranges or limitations (e.g., from about 1 to about 10 includes, 2, 3, 4, etc.; greater than 0.10 includes 0.11, 0.12, 0.13, and so forth). Use of the term "optionally" with respect to any element of a claim is intended to mean that the subject element is required, or alternatively, is not required. Both alternatives are intended to be within the scope of the claim. Use of broader terms such as comprises, includes, having, etc. should be understood to provide support for narrower terms such as consisting of, consisting essentially of, comprised substantially of, and the like.

Modifications, additions, or omissions may be made to the systems and apparatuses described herein without departing from the scope of the invention. The components of the systems and apparatuses may be integrated or separated. Moreover, the operations of the systems and apparatuses may be performed by more, fewer, or other components. The methods may include more, fewer, or other steps. Additionally, steps may be performed in any suitable order.

Accordingly, the scope of protection is not limited by the description set out above but is only limited by the claims which follow, that scope including all equivalents of the subject matter of the claims. Each and every claim is incorporated into the specification as an embodiment of the present invention. Thus, the claims are a further description and are an addition to the preferred embodiments of the present invention. The disclosures of all patents, patent applications, and publications cited herein are hereby incorporated by reference, to the extent they provide exemplary, procedural or other details supplementary to those set forth herein.

We claim:

1. A method of producing hydrocarbons from biomass, the method comprising:

converting at least a portion of the biomass into a carboxylic acid, a ketone, or an ammonium carboxylate salt; reacting at least one of a portion of the carboxylic acid, a portion of the ketone, or a portion of the ammonium carboxylate salt in an oligomerization reactor as at least part of a process that produces an oligomerization product; and separating hydrocarbons from the oligomerization product.

2. The method of claim **1**, further comprising: converting another portion of the carboxylic acid, another portion of the ketone, or another portion of the ammonium carboxylate salt to alcohol; and providing at least a portion of the alcohol to the oligomerization reactor for the process that produces the oligomerization product.

3. The method of claim **2**, wherein converting the another portion of the carboxylic acid into alcohol comprises: reacting the another portion of the carboxylic acid with an olefin to produce an ester; and hydrogenolyzing the ester to produce the alcohol.

4. The method of claim **2**, wherein reacting at least one of the portion of the carboxylic acid, the portion of the ketone, or the portion of the ammonium carboxylate salt in the oligomerization reactor as at least part of the process that produces the oligomerization product and converting the another portion of the carboxylic acid, the another portion of the ketone, or the another portion of the ammonium carboxylate salt to alcohol are carried out in the oligomerization reactor.

5. The method of claim **4**, wherein reacting at least one of the portion of the carboxylic acid, the portion of the ketone, or the portion of the ammonium carboxylate salt in the oligomerization reactor as at least part of the process that produces the oligomerization product and converting the another portion of the carboxylic acid, the another portion of the ketone, or the another portion of the ammonium carboxylate salt to alcohol are carried out with one catalyst.

6. The method of claim **2**, further comprising: separating a recycle stream from the oligomerization product; processing the recycle stream in a reformer to produce hydrogen; and providing at least a portion of the produced hydrogen for the process of converting the another portion of the carboxylic acid, the another portion of the ketone, or the another portion of the ammonium carboxylate salt to alcohol.

7. The method of claim **6**, wherein at least a portion of the biomass is converted to the ammonium carboxylate salt, the method further comprising: separating ammonia from the recycle stream prior to processing the recycle stream in a reformer to produce hydrogen.

8. The method of claim **6**, further comprising: separating olefins from the recycle stream prior to processing the recycle stream in a reformer to produce hydrogen; and providing the olefins to the oligomerization reactor for the process that produces the oligomerization product.

9. The method of claim **8**, wherein at least a portion of the biomass is converted to an ammonium carboxylate salt, the method further comprising: separating ammonia from the recycle stream prior to processing the recycle stream in a reformer to produce hydrogen.

10. The method of claim **2**, further comprising: separating a recycle stream from the oligomerization product; separating olefins from the recycle stream; and providing the olefins to the oligomerization reactor for the process that produces the oligomerization product.

11. The method of claim **1**, wherein at least a portion of the biomass is converted into a carboxylic acid.

12. The method of claim **1**, wherein converting at least a portion of the biomass into a carboxylic acid comprises: fermenting the biomass to produce a carboxylate salt; and converting the carboxylate salt to carboxylic acid using an acid recovery process.

13. The method of claim **1**, wherein at least a portion of the biomass is converted into a ketone.

14. The method of claim **13**, wherein converting at least a portion of the biomass into a ketone comprises: fermenting the biomass to produce a carboxylate salt; and thermally converting the carboxylate salt into the ketone.

15. The method of claim **13**, wherein converting at least a portion of the biomass into a ketone comprises: fermenting the biomass to produce a carboxylate salt; converting the carboxylate salt to carboxylic acid using an acid recovery process, and catalytically converting carboxylic acid into ketone.

16. The method of claim **13**, further comprising converting another portion of the ketone into alcohol by hydrogenating the another portion of the ketone.

17. The method of claim **1**, wherein converting at least a portion of the biomass into a ketone comprises: fermenting the biomass to produce a carboxylate salt; and producing hot ketone vapors and carbonate in a ketone reactor operated with a sweep gas.

18. The method of claim **17** wherein the sweep gas is reactive, condensable or both.

19. The method of claim **18** wherein the sweep gas comprises hydrogen or steam.

20. The method of claim **18** wherein the sweep gas comprises steam.

21. The method of claim **1**, wherein at least a portion of the biomass is converted into the ammonium carboxylate salt.

22. The method of claim **21**, wherein the conversion to ammonium carboxylate salt further comprises converting another portion of the ammonium carboxylate salt to alcohol; and providing the alcohol to the oligomerization reactor for the process that produces the oligomerization product, wherein converting the another portion of the ammonium carboxylate salt into alcohol comprises: converting the another portion of the ammonium carboxylate salt into a second carboxylic acid; reacting the second carboxylic acid with an olefin to produce an ester; and hydrogenolyzing the ester to produce the alcohol.

23. The method of claim **21**, further comprising: separating ammonia from the ammonium carboxylate salt prior to reacting the portion of the ammonium carboxylate salt in the oligomerization reactor as at least part of the process that produces the oligomerization product.

24. The method of claim **1**, wherein converting at least a portion of the biomass into a carboxylic acid, a ketone, or an ammonium carboxylate salt comprises a fermentation process in a fermenter, the method further comprising: separating a gaseous recycle stream from the oligomerization product; and providing at least a portion of the gaseous recycle stream to the fermenter.

25. The method of claim **24**, further comprising: converting another portion of the carboxylic acid, another portion of the ketone, or another portion of the ammonium carboxylate salt to alcohol; and providing the alcohol to the oligomerization reactor.

26. The method of claim **25**, wherein at least a portion of the biomass is converted into a carboxylic acid.

27. The method of claim **25**, wherein at least a portion of the biomass is converted into a ketone.

28. The method of claim **25**, wherein at least a portion of the biomass is converted into an ammonium carboxylate salt.

37

29. The method of claim 28, further comprising: separating ammonia from the gaseous recycle stream prior to providing the at least a portion of the gaseous recycle stream to the fermenter.

30. The method of claim 25, wherein reacting at least one of the portion of the carboxylic acid, the portion of the ketone, or the portion of the ammonium carboxylate salt in the oligomerization reactor as at least part of the process that produces the oligomerization product and converting the another portion of the carboxylic acid, the another portion of the ketone, or the another portion of the ammonium carboxylate salt to alcohol are carried out in the oligomerization reactor.

31. The method of claim 30, wherein reacting at least one of the portion of the carboxylic acid, the portion of the ketone, or the portion of the ammonium carboxylate salt in the oli-

38

gomerization reactor as at least part of the process that produces the oligomerization product and converting the another portion of the carboxylic acid, the another portion of the ketone, or the another portion of the ammonium carboxylate salt to alcohol are carried out with one catalyst.

32. The method of claim 25, further comprising: separating fermenter gases exiting the fermenter; processing the fermenter gases in a reformer to produce hydrogen; and providing a least a portion of the produced hydrogen for the process of converting the another portion of the carboxylic acid, the another portion of the ketone, or the another portion of the ammonium carboxylate salt to alcohol.

* * * * *