



(12) **United States Patent**
Toliyat et al.

(10) **Patent No.: US 6,426,605 B1**
(45) **Date of Patent: Jul. 30, 2002**

(54) **MULTI-PHASE INDUCTION MOTOR DRIVE SYSTEM AND METHOD**

(75) Inventors: **Hamid A. Toliyat; Ruhe Shi**, both of College Station; **Huangsheng Xu**, Bryan, all of TX (US)

(73) Assignee: **The Texas A&M University System**, College Station, TX (US)

(*) Notice: Subject to any disclaimer, the term of this patent is extended or adjusted under 35 U.S.C. 154(b) by 0 days.

(21) Appl. No.: **09/617,393**

(22) Filed: **Jul. 17, 2000**

Related U.S. Application Data

(60) Provisional application No. 60/144,102, filed on Jul. 16, 1999.

(51) **Int. Cl.**⁷ **H02P 5/41**

(52) **U.S. Cl.** **318/801; 318/807; 318/448**

(58) **Field of Search** 318/798, 799, 318/800, 801, 807, 611, 448, 702

(56) **References Cited**

U.S. PATENT DOCUMENTS

- 4,306,182 A * 12/1981 Curtiss 318/811
- 4,445,080 A * 4/1984 Curtiss 318/798
- 4,808,903 A * 2/1989 Matsui et al. 318/800
- 5,668,457 A * 9/1997 Motamed 318/606

OTHER PUBLICATIONS

H. A. Toliyat, et al.; "Analysis of a Concentrated Winding Induction Machine for Adjustable Speed Drive Applications—Part I (Motor Analysis);" IEEE-PES Winter Meeting, Dec., 1991 all.

H. A. Toliyat, et al.; "Analysis of a Concentrated Winding Induction Machine for Adjustable Speed Drive Applications—Part II (Motor Design and Performance);" IEEE Transaction on Energy Conversion, vol. 6, No. 4, pp. 685–692, Dec. 1991.

H. A. Toliyat, et al.; "Analysis of Concentrated Winding Inducton Machines for Adjustable Speed Drive Applications—Experimental Results;" IEEE Transactions on Energy Conversion, vol. 9, No. 4, pp. 694–700, Dec. 1994.

G. W. McLean, et al.; "Performance and design of induction motors with square wave excitation;" Proc. Inst. Elec. Eng.; vol. 116; pp. 1405–1411, Jun. 1969.

K. N. Pavithran, et al; "A novel polyphase reference sin wave generator using multiplexing technique;" IEEE Trans. Ind. Electron.; vol. IE-33, No. 3; pp. 342–344, Aug. 1986.

(List continued on next page.)

Primary Examiner—Bentsu Ro

(74) *Attorney, Agent, or Firm*—Baker Botts L.L.P.

(57) **ABSTRACT**

A multiphase induction motor system is disclosed. The system comprises a motor having at least five phases and comprising a stator and a rotor. For each phase, the motor receives a command current to power the motor, where the command current has a fundamental frequency. A processor determines, for each phase, at least one harmonic component of a signal indicative of the fundamental frequency, generates a command current from the harmonic component and the fundamental frequency, and supplies the command current to the stator. A method for operating a multiphase induction motor system is disclosed. A first command current is supplied to a motor having at least five phases, where the first command current powers the motor. The first command current has a fundamental frequency, and the motor comprises a stator and a rotor. For each phase, at least one harmonic component of a signal indicative of the fundamental frequency is determined. A second command current is generated from the harmonic component and the fundamental frequency. The second command current is supplied to the stator.

9 Claims, 3 Drawing Sheets

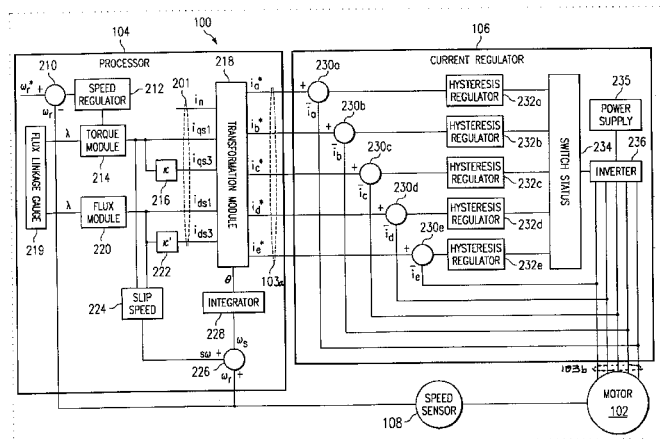

OTHER PUBLICATIONS

- J. McGuinness; "Advantages of Five Phase Motors in Microstepping Drive;" Stepper Motors and Their Control, IEE Colloquium; pp. 1/1-1/6, 1994.
- A. V. Brazhnikov, et al.; "Control potentials and Advantages of Multiphase AC Drives;" Power Electronics Specialists Conference; PESC 98 Record. 29th Annual IEEE, vol. 2; pp. 2108-2114, Aug. 1998.
- H. A. Toliyat, et al.; "dq Modeling of Five Phase Synchronous Reluctance Machines Including Third Harmonic of Air-Gap MMF;" Proceedings of the IEEE-IAS Annual Meeting Conference; pp. 231-237, Nov. 1991.
- H. A. Toliyat, et al.; "Analysis and Modeling of Five Phase Converters For Adjustable Speed Drive Applications;" Proceedings of the 5th European Conference on Power Electronics and Applications (EPE'93); pp. 194-199, Sep. 13-16, 1993.
- H. A. Toliyat; "Analysis and Simulation of Multi-Phase Variable Speed Induction Motor Drives Under Asymmetrical Connections;" IEEE Trans. on Power Electronics, vol. 13, No. 4; pp. 748-756, Jul. 1998.
- Hamid A. Toliyat, et al.; "A Five-Phase Reluctance Motor with High Specific Torque;" IEEE Transaction on Industry Applications; vol. 28, No. 3; pp. 659-667, May/June. 1992.
- C.C. Chan, et al.; "A Novel Polyphase Multipole Square-Wave Permanent Magnet Motor Drive for Electric Vehicles;" IEEE Transactions, vol. 30, No. 5; pp. 1258-1266, Sep.-Oct. 1994.
- Yuriy Kats; "Adjustable-Speed Drives With Multiphase Motors;" Electric Machines and Drives Conference Record; IEEE International; pp. TC2/4.1-TC2/4.3, 1997.
- Hamid A. Toliyat; "Analysis and Simulation of Five-Phase Variable-Speed Induction Motor Drives Under Asymmetrical Connections;" IEEE Transactions on Power Electronics, vol. 13, No. 4; pp. 748-756, Jul. 1998.
- Hamid A. Toliyat, et al.; "Parameter Estimation Algorithm using Spectral Analysis for Vector Controlled Induction Motor Drives;" IEEE International Symposium on Industrial Electronics; pp. 90-95, 1993.
- H. Toliyat, et al.; Rotor Time Constant Updating Scheme for a Rotor Flux Oriented Induction Motor Drive; IEEE Power Electronics Specialists Conference; 1995; 26th; vol. 2; pp. 1302-1306.
- Hamid A. Toliyat, et al.; "A Novel Direct Torque Control (DTC) Method for Five-Phase Induction Machines;" Proceedings of the 2000 Applied Power Electronics Conference (APEC '00); New Orleans, LA, Feb. 6-10, 2000.

* cited by examiner

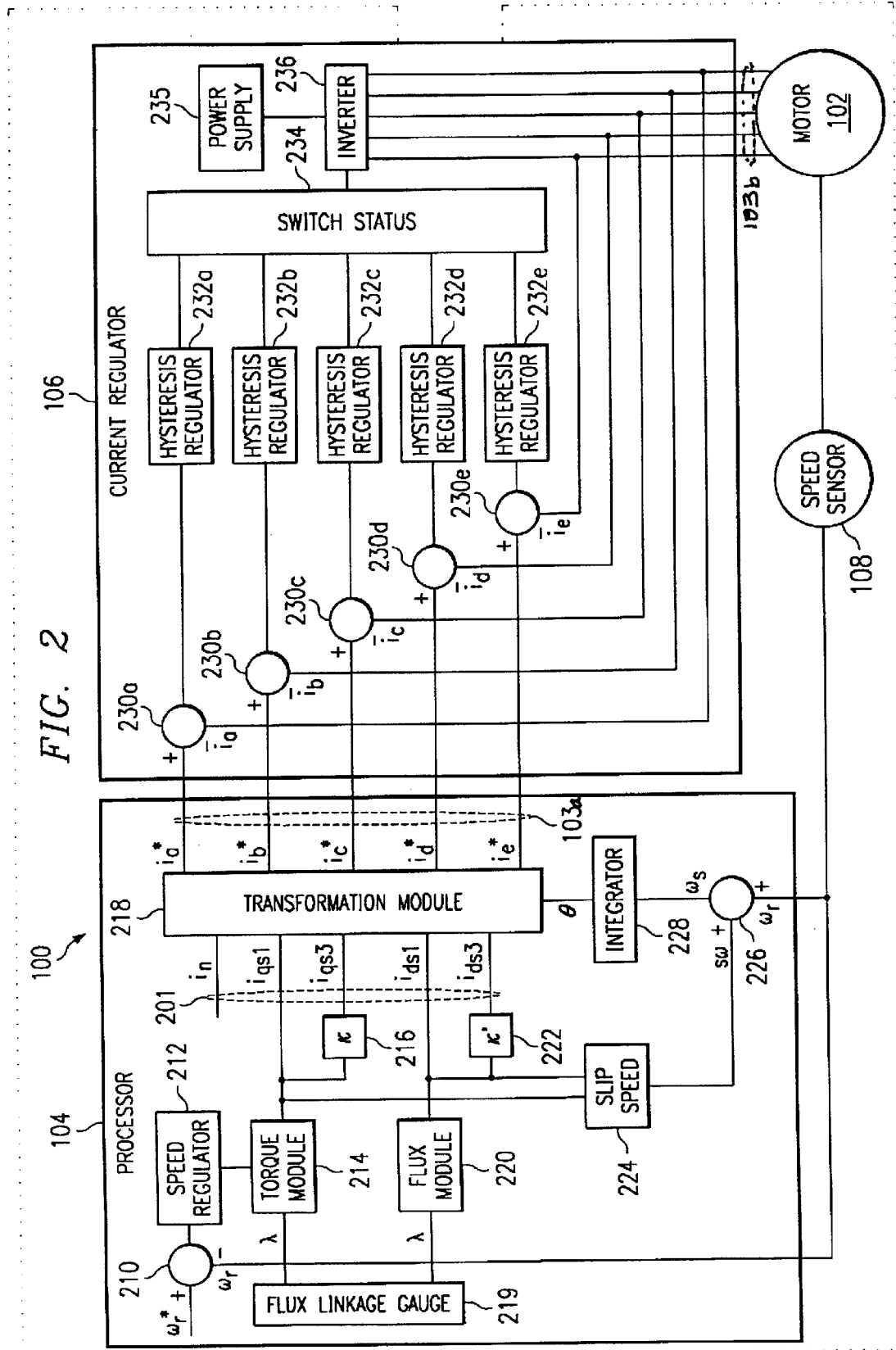
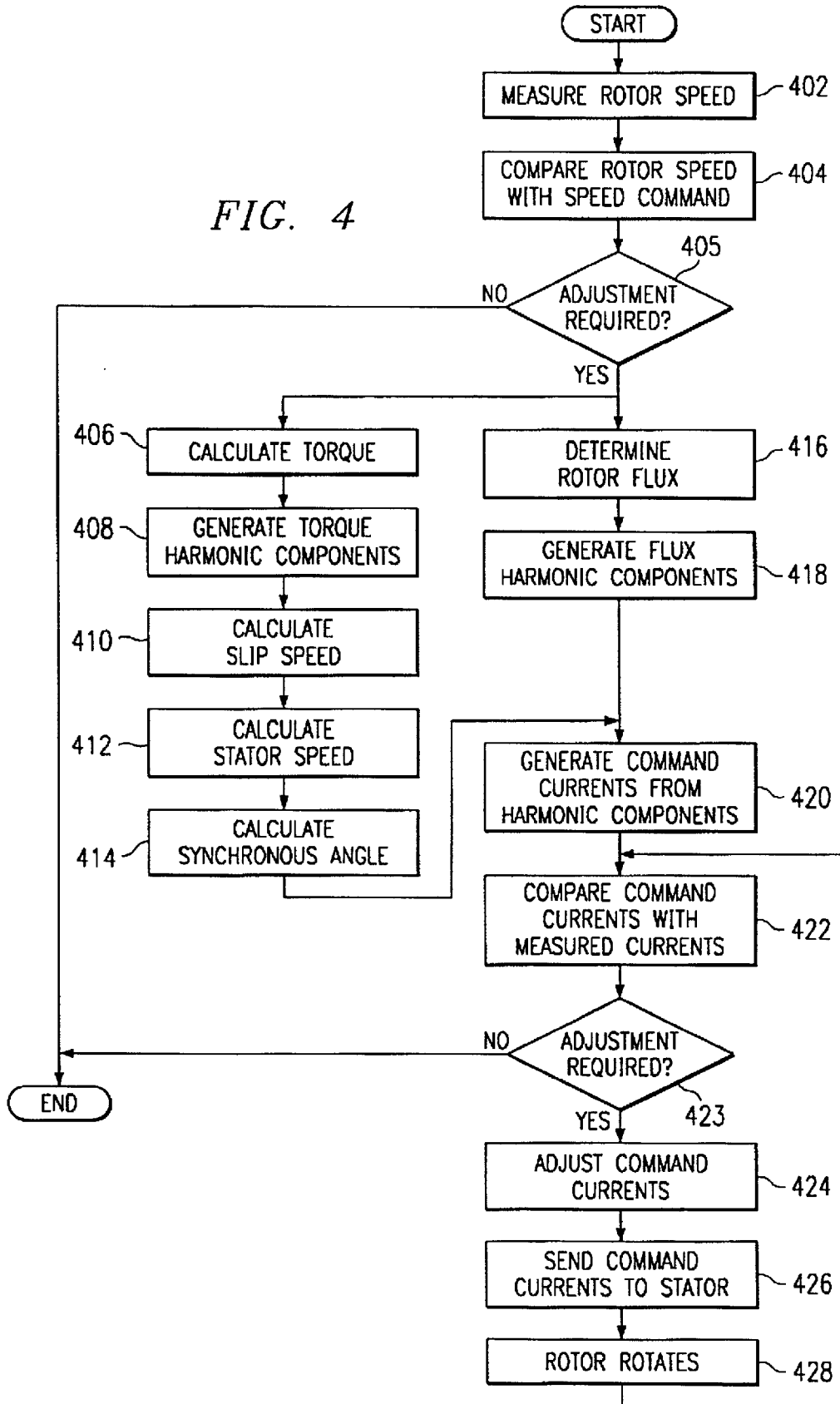

FIG. 4



MULTI-PHASE INDUCTION MOTOR DRIVE SYSTEM AND METHOD

RELATED APPLICATION

This application claims benefit under 35 U.S.C. § 119 of U.S. provisional application Ser. No. 60/144,102, entitled Five Phase Induction Drive System and Method, which was filed on Jul. 16, 1999.

GOVERNMENT INTEREST

The invention was made with Government support under Contract N00014-98-1-0717 awarded by Office of Naval Research, Arlington, Va. 22217-5660. The Government may have certain rights in the invention.

TECHNICAL FIELD OF THE INVENTION

This invention relates generally to the field of motor drive systems and more specifically to a multi-phase induction motor drive system and method.

BACKGROUND OF THE INVENTION

The need for efficient motors has led to the demand for improved multi-phase induction motor drive systems and methods. Engineers are faced with the problem of designing motors that yield greater power and torque density. For example, motors powered by inverters often do not achieve high power output. Inverters impress rectangular voltage or current output on motors that are typically designed to receive sinusoidal input, thus reducing the power capabilities of the motors. Additionally, motors designed to receive sinusoidal input typically produce low torque output. Accordingly, designing motors that yield greater power and torque density has posed a challenge for engineers.

SUMMARY OF THE INVENTION

While known approaches have provided improvements over prior approaches, the challenges in the field of drive systems have continued to increase with demands for more and better techniques having greater effectiveness. Therefore, a need has arisen for a multi-phase induction motor drive system and method.

In accordance with the present invention, a multi-phase induction motor drive system and method are provided that substantially eliminate or reduce the disadvantages and problems associated with previously developed systems and methods.

According to one embodiment of the present invention, a multi-phase induction motor drive system is disclosed. The system comprises a motor having at least five phases and comprising a stator and a rotor. For each phase, the motor receives a command current to power the motor, where the command current has a fundamental frequency. A processor determines, for each phase, at least one harmonic component of a signal indicative of the fundamental frequency, generates a command current from the harmonic component and the fundamental frequency, and supplies the command current to the stator.

According to another embodiment of the present invention, a method for operating a multi-phase induction motor drive system is disclosed. A first command current is supplied to a motor having at least five phases, where the first command current powers the motor. The first command current has a fundamental frequency, and the motor comprises a stator and a rotor. For each phase, at least one

harmonic component of a signal indicative of the fundamental frequency is determined. A second command current is generated from the harmonic component and the fundamental frequency. The second command current is supplied to the stator.

Embodiments of the invention may provide numerous technical advantages. For example, a technical advantage of one embodiment is that the power density of a motor may be improved by enhancing the motor's ability to utilize rectangular current input. Another technical advantage of one embodiment is that a combination of harmonic components of a fundamental frequency may be used to increase torque density. Another technical advantage of one embodiment is that a multi-phase motor may be able to operate under loss of one or more phases, increasing the reliability of the motor. Another technical advantage of one embodiment is that the flux of the multi-phase motor may be more evenly distributed than that of known motors, thus decreasing the torque pulsation and lowering acoustic noise in the motor.

Other technical advantages are readily apparent to one skilled in the art from the following figures, descriptions, and claims.

BRIEF DESCRIPTION OF THE DRAWINGS

For a more complete understanding of the present invention and for further features and advantages, reference is now made to the following description, taken in conjunction with the accompanying drawings, in which:

FIG. 1 is a block diagram of one embodiment of a multi-phase induction motor drive system according to the teachings of the present invention;

FIG. 2 is a block diagram of one embodiment of a processor and a current regulator of FIG. 1 according to the teachings of the present invention;

FIG. 3 is a block diagram of one embodiment of an inverter of FIG. 2 according to the teachings of the present invention; and

FIG. 4 is a flowchart of one embodiment of method for operating a multi-phase induction motor drive system.

DETAILED DESCRIPTION OF THE DRAWINGS

Embodiments of the present invention and its advantages are best understood by referring to FIGS. 1 through 4 of the drawings, like numerals being used for like and corresponding parts of the various drawings.

FIG. 1 is a block diagram of one embodiment of a multi-phase induction motor drive system **100** according to the teachings of the present invention. System **100** comprises a motor **102**, a processor **104**, a current regulator **106**, and a speed sensor **108**. As described in greater detail below, system **100** produces a substantially rectangular air gap flux density in motor **102**. Such a flux density results in increased power and torque density. Processor **104**, which is described in connection with FIG. 2, receives feedback from motor **102** and generates command currents **103a** in response to the feedback. The feedback comprises motor speed information. Command currents **103** power motor **102** and, like prior systems, include a fundamental frequency of substantially sinusoidal shape. According to the teachings of the invention, command currents **103a** are generated from the fundamental frequency and a harmonic component of the fundamental frequency in order to induce a substantially rectangular air gap flux density. Current regulator **106**, which is described in connection with FIG. 2, receives feedback from motor **102** and adjusts the command currents

103a in response to the feedback. The feedback comprises motor current information. Current regulator **106** transmits the adjusted command currents **103b** to motor **102**. Motor **102** is designed to produce a substantially rectangular air gap flux density when supplied with command currents **103b**, resulting in enhanced power and torque density.

In one embodiment, motor **102** comprises a multi-phase induction motor, for example, a five phase induction motor, and has any suitable number of poles, for example, two or four poles. Motor **102** includes a rotor **110** that rotates within a stator **112**. Speed sensor **108** may be used to measure the rotation speed of rotor **110**. An air gap **120** is located substantially between rotor **110** and stator **112**.

Stator **112** is shaped to accommodate the rotation of rotor **110**, and may be, for example, cylindrical with a diameter **128**. A stator lamination **122** may comprise, for example, silicon and steel. A plurality of stator slots **124** are formed within stator lamination **122**. A plurality of stator windings **126** are located substantially within stator slots **124**. Stator windings **126** are used to create a magnetic field, and may comprise, for example, copper, aluminum, or other suitable conductive material. Stator windings may be concentrated, instead of sinusoidal, in order to achieve a substantially rectangular air gap flux density. Stator windings **126** are associated with a phase of a multi-phase induction motor **102**. Stator windings **126** may be full pitch, that is, stator windings **126** associated with one phase may be located at opposing ends of a diameter **128** of stator **112**. For example, stator winding **126a** located at one end of diameter **128** and stator winding **126f** located at the other end are associated with one phase. Stator windings **126** may be evenly spaced around stator **112**. For example, the angle α between stator windings **126a**, **126b**, **126c**, **126d**, and **126e** representing positive poles may be approximately 72° .

Rotor **110** is shaped to rotate within stator **112**, and may be, for example, cylindrical with an axis about which rotor **110** rotates. Rotor **110** includes a shaft **114** located substantially at the axis of rotation. Disposed outwardly from shaft **114** is a rotor lamination **116**. Rotor lamination **116** may comprise, for example, silicon and steel. Substantially embedded in rotor lamination **116** are a plurality of rotor bars **118**. Rotor bars **118** may comprise, for example, copper, aluminum, or other suitable conductive material. Rotor **110** may include any suitable number of rotor bars **118**, for example, at least twenty, such as twenty-eight rotor bars **118**, substantially equally placed around rotor **110**. In one embodiment, rotor bars **118** may be not skewed. The number of stator windings **126** and rotor bars **118** may be selected as to yield a rectangular or substantially rectangular flux distribution in air gap **120**, in response to the input of proper command currents. A motor that has a rectangular air gap flux distribution may yield higher torque density and power output because the conductive material of the motor, for example, iron, is utilized more effectively. For example, a five-phase induction motor with a rectangular air gap flux distribution may generate more power and torque density than that generated by a sinusoidal three-phase induction motor, while using the same amount of material used by the three-phase motor.

Motor **102** with command currents **103b** generated from a fundamental frequency and a harmonic component of the fundamental frequency may be described as a plurality of independent motors, one with command currents **103** generated from the fundamental frequency and one with command currents generated from the harmonic component. The fundamental frequency may be associated with a fundamental frequency of command currents **103b**. For example, a

five-phase induction motor may have command currents **103**, represented by i_a^* , i_b^* , i_c^* , i_d^* , and i_e^* , generated from the fundamental (or first) and third harmonic components of a fundamental frequency, such that:

$$i_k^* = i_{k1}^* + i_{k3}^*, \quad k=a, b, c, d, e$$

where the number index refers to the harmonic component, for example, the first and third harmonic components. Thus, for example, motor **102** may be described as two motors, one with command currents i_{a1}^* , i_{b1}^* , i_{c1}^* , i_{d1}^* , and i_{e1}^* , and one with command currents i_{a3}^* , i_{b3}^* , i_{c3}^* , i_{d3}^* , and i_{e3}^* .

To describe the five-phase induction motor, a q_1 - d_1 - q_3 - d_3 -n model may be used in place of the well-known q-d model. The q_1 - d_1 - q_3 - d_3 -n model includes a q_1 -axis and a d_1 -axis, which refer to the q-axis and d-axis, respectively, of a rotor of a motor with command currents i_{a1}^* , i_{b1}^* , i_{c1}^* , i_{d1}^* , and i_{e1}^* . Similarly, a q_3 -axis and a d_3 -axis refer to the q-axis and d-axis, respectively, of a rotor of a motor with command currents i_{a3}^* , i_{b3}^* , i_{c3}^* , i_{d3}^* , and i_{e3}^* .

The dynamic behavior of the five-phase induction motor may be described in the q_1 - d_1 - q_3 - d_3 -n model by flux linkage Equations (1) through (11) in an arbitrary rotating reference frame:

$$\lambda_{qs1} = L i_{qs1} + L_{m1} (i_{qs1} + i'_{qr1}) \quad (1)$$

$$\lambda_{ds1} = L i_{ds1} + L_{m1} (i_{ds1} + i'_{dr1}) \quad (2)$$

$$\lambda_{qs3} = L i_{qs3} + L_{m3} (i_{qs3} + i'_{qr3}) \quad (3)$$

$$\lambda_{ds3} = L i_{ds3} + L_{m3} (i_{ds3} + i'_{dr3}) \quad (4)$$

$$\lambda_{ns1} = L i_{ns1} \quad (5)$$

$$\lambda'_{qr1} = L i'_{qr1} + L_{m1} (i_{qs1} + i'_{qr1}) \quad (6)$$

$$\lambda'_{dr1} = L i'_{dr1} + L_{m3} (i_{ds1} + i'_{dr1}) \quad (7)$$

$$\lambda'_{qr3} = L i'_{qr3} + L_{m3} (i_{ds3} + i'_{qr3}) \quad (8)$$

$$\lambda'_{dr3} = L i'_{dr3} + L_{m3} (i_{ds3} + i'_{dr3}) \quad (9)$$

$$\lambda'_{nr} = \lambda'_{nr} \quad (10)$$

where λ is flux linkage, L is inductance, i is current, l is leakage, m is magnetizing, s is stator **112**, and r is rotor **110**. The primes indicate rotor variables transferred to the stator side. The electromagnetic torque is given by Equation (11):

$$T_e = \frac{5}{2} p [L_{m1} (i_{ds1} i'_{qr1} - i_{qs1} i'_{dr1}) + 3L_{m3} (i_{ds3} i'_{qr3} - i_{qs3} i'_{dr3})] \quad (11)$$

$$T_e - T_L = J_m \frac{d\omega_r}{dt} \quad (12)$$

where:

$$L_{m1} = \frac{5}{2} L_{ms1}$$

$$L_{m3} = \frac{5}{2} L_{m3} \text{ and}$$

$$p = \frac{d}{dt}$$

and J_m is the mechanical motion inertia.

In operation, processor **104** generates command currents **103a** for motor **102** in response to speed feedback from motor **102**. Current regulator **106** adjusts command currents **103a** in response to current feedback from motor **102** and sends adjusted command currents **103b** to motor **102**. Com-

mand currents **103b** are passed through stator windings **126** to create magnetic fields in stator **112**. The lines of force of each magnetic field revolve around stator windings **126**, which induces a current in rotor bars **118**. In response, rotor **110** generates a magnetic field attracted to the magnetic field of stator **112**. As the magnetic field of stator **112** revolves around stator windings **126**, rotor **110** rotates. In order to maintain rotation of rotor **110**, the magnetic field of the rotor **110** lags behind the magnetic field of stator **112**. The slip speed is the difference between speeds of rotations.

System **100** includes a five or more phase motor **102**, which may have substantially concentrated stator windings **126**, and processor **104** that generates command currents **103a** from a harmonic component of a fundamental frequency. As a result, system **100** produces a substantially rectangular air gap flux density in motor **102**. Such flux density results in higher power and torque density than that of an equivalent sinusoidally wound three-phase motor using the same amount of material. Additional details of processor **104**, current regulator **106**, and inverter **236** are described in FIGS. **2** and **3**. A method for operating system **100** is described in FIG. **4**.

FIG. **2** is a block diagram of one embodiment of processor **104** and current regulator **106** of FIG. **1** according to the teachings of the present invention. Processor **104** generates command currents **103a** that may achieve a substantially rectangular air gap flux distribution in motor **102**. In this example, the fundamental and third harmonic components **201** are associated with a fundamental frequency of a command current **103b** are used to generate command currents **103a** for the motor. Any suitable harmonic components, however, may be used. For example, the (n-2) harmonic components may be used to generate command currents for an n-phase motor, where n=5, 7, 9 For convenience, currents having the harmonic components **201** are represented by i_{qs1}^* , i_{qs3}^* , i_{ds1}^* , i_{ds3}^* and i_n . The fundamental frequency may be determined from a signal from speed sensor **108** indicating the fundamental frequency of a command current **103b**.

An adder **210** receives a measured rotor speed ω_r from speed sensor **108** and a rotor speed command ω_r^* input into processor. For convenience, commands are designated with an asterisk to distinguish the commands from measurements. Adder **210** compares rotor speed command ω_r^* with the measured rotor speed ω_r to determine a speed error, the difference between the two speeds. A flux linkage gauge **219** measures the flux linkage λ_r of rotor **110**.

A flux linkage gauge **219** measures rotor flux linkage λ_r . A speed regulator **212** uses the speed error to compute a torque reference value T_e^* , where e refers to electromagnetic. Equation (12) may be used to compute torque reference value T_e^* . A torque module **214** uses the torque reference value T_e^* and the rotor flux linkage λ_r to compute a torque producing harmonic component current of the fundamental frequency, that is, torque harmonic component current i_{qs1}^* . Equations (13), (14), and (15) may be used to compute harmonic component current i_{qs1}^* of the fundamental frequency:

$$T_{e1} = \frac{5}{2} \frac{P}{2} \frac{L_{m1}}{L_{r1}} i_{qs1} \lambda_{dr1}; \quad (13)$$

$$T_{e3} = 3 \frac{5}{2} \frac{P}{2} \frac{L_{m3}}{L_{r3}} i_{qs3} \lambda_{dr3}; \quad (14)$$

$$T_e = T_{e1} + T_{e3} \quad (15)$$

where P refers to the number of poles. A multiplier **216** multiplies the torque harmonic component current i_{qs1}^* by

a constant K to yield another harmonic component current, for example, a third harmonic component current i_{qs3}^* . Constant K may be within a range of 0.5 to 0.20, for example, 0.15, such that the amplitude of harmonic component current i_{qs3}^* is 0.15 the amplitude of harmonic component current i_{qs1}^* . The fundamental harmonic component current i_{qs1}^* and the third harmonic component current i_{qs3}^* change in response to the speed error in order to minimize the speed error, resulting in the steady state of motor **102**. Harmonic component currents i_{qs1}^* and i_{qs3}^* of the fundamental frequency are sent to transformation module **218**.

A flux linkage gauge **219** measures the rotor flux linkage λ_{dr1} which is transmitted to a flux module **220**. Flux module **220** generates a flux producing harmonic component current of the fundamental frequency, for example, a fundamental harmonic component current i_{ds1}^* , from the rotor flux linkage λ_{dr1} . Equations (16) and (17) may be used to generate the flux harmonic component current i_{ds1}^* :

$$\lambda_{dr1} = \lambda_{r1} = L_{m1} i_{ds1} \quad (16)$$

$$\lambda_{dr3} = \lambda_{r3} = L_{m3} i_{ds3} \quad (17)$$

where

$$p = \frac{d}{dt}$$

A multiplier **222** multiplies the fundamental harmonic component current i_{ds1}^* by a constant K' in order to calculate another harmonic component current, for example, a third harmonic component current i_{ds3}^* . Constant K' may be within a range of 0.5 to 0.20, for example, 0.15, such that the amplitude of harmonic component current i_{ds3}^* is 0.15 the amplitude of harmonic component current i_{ds1}^* . The first harmonic component current i_{ds1}^* and the third harmonic component current i_{ds3}^* of the fundamental frequency are sent to transformation module **218**.

A slip speed module **224** computes slip speed so from harmonic component current i_{qs1}^* received from torque module **214** and harmonic component current i_{ds1}^* from flux module **220** using Equations (18) and (19) may be used to compute slip speed $s\omega$:

$$s\omega_{s1} = \frac{r_r i_{qs1}}{L_{r1} i_{ds1}} \quad (18)$$

$$s\omega_{s3} = 3 \frac{R_r i_{qs3}}{L_{r3} i_{ds3}} \quad (19)$$

where R refers to resistance.

An adder **226** receives slip speed $s\omega$ from slip speed module **224** and rotor speed ω_r from speed sensor **108** and computes the stator speed ω_s from the received speeds. An integrator **228** computes a synchronous angle θ from the stator speed ω_s and transmits synchronous angle θ to transformation module **218**.

Transformation module **218** transforms harmonic component currents i_{qs1}^* , i_{qs3}^* , i_{ds1}^* and i_{ds3}^* and an additional harmonic component current i_n^* into command currents i_a^* , i_b^* , i_c^* , i_d^* , and i_e^* by transforming the harmonic component currents from a conventional coordinate system defined by the rest frame of motor **102** to a coordinate system defined by the q-axis coordinate system of rotor **110**. Harmonic component current i_n^* , which represents n-axis current, is assumed to be zero because of the symmetry of motor **102**. Transformation module **218** may use Equation (20) to perform the transformation:

$$T(\theta) = \frac{2}{5} \begin{bmatrix} \cos\theta & \cos\left(\theta - \frac{2\pi}{5}\right) & \cos\left(\theta - \frac{4\pi}{5}\right) & \cos\left(\theta + \frac{4\pi}{5}\right) & \cos\left(\theta + \frac{2\pi}{5}\right) \\ \sin\theta & \sin\left(\theta - \frac{2\pi}{5}\right) & \sin\left(\theta - \frac{4\pi}{5}\right) & \sin\left(\theta + \frac{4\pi}{5}\right) & \sin\left(\theta + \frac{2\pi}{5}\right) \\ \cos 3\theta & \cos 3\left(\theta - \frac{2\pi}{5}\right) & \cos 3\left(\theta - \frac{4\pi}{5}\right) & \cos 3\left(\theta + \frac{4\pi}{5}\right) & \cos 3\left(\theta + \frac{2\pi}{5}\right) \\ \sin 3\theta & \sin 3\left(\theta - \frac{2\pi}{5}\right) & \sin 3\left(\theta - \frac{4\pi}{5}\right) & \sin 3\left(\theta + \frac{4\pi}{5}\right) & \sin 3\left(\theta + \frac{2\pi}{5}\right) \\ \frac{1}{\sqrt{2}} & \frac{1}{\sqrt{2}} & \frac{1}{\sqrt{2}} & \frac{1}{\sqrt{2}} & \frac{1}{\sqrt{2}} \end{bmatrix} \quad (20)$$

Current regulator **106** receives command currents **103a** from processor **104** and adjusts command currents **103a** in response to current feedback received from motor **102**. Adders **230** compare the command currents i_a^* , i_b^* , i_c^* , i_d^* , and i_e^* with measured currents i_a , i_b , i_c , i_d , and i_e , respectively, from motor **102** to determine the current error. Hysteresis regulators **232** receive the current error from adders **230** and determine how to minimize the error. For example, if the measured current i_a is greater than the command current i_a^* , the command current i_a^* needs to be decreased. Hysteresis regulators **232** send instructions for minimizing error to switch status module **234**. Switch status module **234** receives the instructions and determines how an inverter **236**, which is described in more detail in connection with FIG. 3, needs to adjust the command currents before sending the currents to stator windings **126**. For example, switch status module **234** determines that command current i_a^* needs to be switched in the negative direction to decrease the current.

Thus, processor **104** operates to provide the proper command currents **103** to motor **102**. Command currents **103** are generated from multiple harmonic components of a fundamental frequency to induce a substantially rectangular air flux density in motor **102**, yielding greater power and torque density. Current regulator **106** operates to adjust command currents **103** to ensure that motor **102** maintains a substantially rectangular air gap flux density.

FIG. 3 is a block diagram of inverter **236** of FIG. 2 according to the teachings of the present invention. A power supply **235** supplies a current to inverter. Inverter **236** receives instructions for minimizing error from switch status module **234**. Pairs of transistors **302** operate to adjust the command currents according to the instructions. For example, a pair of transistors **302a** receives an instruction to switch command current i_a^* in the negative direction to decrease the current. After adjusting the command currents, inverter **236** sends the currents to stator windings **126**.

FIG. 4 is a flowchart illustrating a method for operating a multi-phase induction motor drive system, which is described with reference to FIGS. 1 through 3, according to the teachings of the present invention. The method begins at step **402**, where the rotor speed ω_r of motor **102** is measured. Rotor speed ω_r may be measured by using speed sensor **108**. In step **404**, the measured rotor speed ω_r is compared with rotor speed command ω_r^* to calculate a speed error. Adder **210** may be used to compare the measured rotor speed ω_r with speed command ω_r^* . At step **405**, the speed error is used to determine whether an adjustment is required. The speed error may be compared with a predetermined acceptable range of error to determine whether an adjustment is required. If an adjustment is not required, the method terminates. If an adjustment is required, the method proceeds to steps **406** and **410**.

At step **406**, a torque reference value T_e^* is calculated from the speed error. Speed regulator **212** may be used to

compute the torque reference value T_e^* . At step **408**, torque producing harmonic component currents i_{qs1}^* and i_{qs3}^* of a fundamental frequency are generated from the torque reference value T_e^* . The fundamental frequency may be determined from a signal from speed sensor **108** indicating the fundamental frequency of a command current **103b**. Torque module **214** may be used to determine harmonic component current i_{qs1}^* . Multiplier **216** may be used to compute harmonic component current i_{qs3}^* from harmonic component current i_{qs1}^* . Harmonic component currents i_{qs1}^* and i_{qs3}^* are sent to transformation module **218**.

At step **410**, the slip speed $s\omega$ is determined using torque reference value T_e^* and rotor flux linkage λ_{dr1} . Slip speed module **224** may be used to compute the slip speed $s\omega$. At step **412**, stator speed ω_s is calculated from slip speed $s\omega$ and rotor speed ω_r . Adder **226** may be used to compute stator speed ω_s . At step **414**, synchronous angle θ is determined from the stator speed ω_s . Integrator **228** may be used to determine the synchronous angle θ .

At step **416**, rotor flux linkage λ_{dr1} is measured using, for example, flux linkage gauge **219**. At step **418**, flux producing harmonic component currents i_{ds1}^* and i_{ds3}^* of the fundamental frequency are generated from rotor flux linkage λ_{dr1} . Flux module **220** may be used to generate harmonic component current i_{ds1}^* . Multiplier **222** may be used to determine harmonic component current i_{ds3}^* from harmonic component current i_{ds1}^* . Harmonic component currents i_{ds1}^* and i_{ds3}^* are sent to transformation module **218**.

As step **420**, command currents i_a^* , i_b^* , i_c^* , i_d^* , and i_e^* are generated from harmonic component currents i_{qs1}^* , i_{qs3}^* , i_{ds1}^* , and i_{ds3}^* . Transformation module **218** may be used to generate the command currents. At step **422**, command currents i_a^* , i_b^* , i_c^* , i_d^* , and i_e^* are compared with measured currents i_a , i_b , i_c , i_d , and i_e . Adders **230** may be used to compare the currents to determine a current error. At step **423**, the current error is used to determine whether an adjustment is required. The current error may be compared with a predetermined acceptable range of current error to determine whether an adjustment is required. If an adjustment is not required, the method terminates. If an adjustment is required, the method proceeds to step **424**.

At step **424**, command currents are adjusted in response to the comparison. Hysteresis regulators **232** may be used to determine how to minimize the current error. Switch status module **234** may be used to determine how inverter **236** needs to adjust the command currents. At step **426**, the command currents are sent to stator **112**. Inverter **236** may be used to send adjusted command currents to stator **112**. At step **428**, rotor **110** rotates in response to the command currents in stator **112**. The method then proceeds to step **422**, where command currents i_a^* , i_b^* , i_c^* , i_d^* , and i_e^* are compared with measured currents i_a , i_b , i_c , i_d , and i_e .

Thus, the method operates to provide the proper command currents **103a** to motor **102**. Command currents **103**

are generated from multiple harmonic components of a fundamental frequency to induce a substantially rectangular air flux density in motor **102**, yielding greater power and torque density. Command currents **103** are adjusted to ensure that motor **102** maintains a substantially rectangular air gap flux density.

Embodiments of the invention may provide numerous technical advantages. For example, a technical advantage of one embodiment is that the power density of a motor may be improved by enhancing the motor's ability to utilize rectangular voltage input. Another technical advantage of one embodiment is that a combination of the harmonic components of a fundamental frequency may be used to increase torque density. Another technical advantage of one embodiment is that a multi-phase motor may be able to operate under loss of one or more phases, increasing the reliability of the motor. Another technical advantage of one embodiment is that the flux of the multi-phase motor may be more evenly distributed than that of known motors, decreasing the torque pulsation, which may lower acoustic noise in the motor.

Although an embodiment of the invention and its advantages are described in detail, a person skilled in the art could make various alterations, additions, and omissions without departing from the spirit and scope of the present invention as defined by the appended claims.

What is claimed is:

1. A multi-phase induction motor drive system, the system comprising:

a motor having at least five phases and comprising a stator and a rotor, the motor, for each phase, operable to receive a command current to power the motor, the command current having a fundamental frequency;

a processor operable to determine, for each phase, at least one harmonic component of a signal indicative of the fundamental frequency, to generate a command current from the harmonic component and the fundamental frequency using a flux module coupled to the processor, and to supply the command current to the stator, wherein the flux module is operable to determine a flux linkage of the rotor and to generate the fundamental frequency and the harmonic component from the flux linkage.

2. The system of claim **1**, wherein the harmonic component has a third harmonic frequency.

3. The system of claim **1**, wherein the amplitude of a current having the harmonic component is five to twenty percent of the amplitude of a current having the fundamental frequency.

4. A multi-phase induction motor drive system, the system comprising:

a motor having at least five phases and comprising a stator and a rotor, the motor, for each phase, operable to receive a command current to power the motor, the command current having a fundamental frequency; and

a processor operable to determine, for each phase, at least one harmonic component of a signal indicative of the fundamental frequency, to generate a command current from the harmonic component and the fundamental frequency, and to supply the command current to the stator, wherein the processor comprises a transformation module operable to generate the command current by transforming currents having the harmonic component and the fundamental frequency from a coordinate system defined by the rest frame of the motor to a coordinate system defined by the q-axis of the rotor.

5. A method of operating a multi-phase induction motor drive, the method comprising:

supplying to a motor having at least five phases a first command current to power the motor, the first command current having a fundamental frequency and the motor comprising a stator and a rotor;

determining, for each phase, at least one harmonic component of a signal indicative of the fundamental frequency;

generating a second command current from the harmonic component and the fundamental frequency, the fundamental frequency and the harmonic component generated from a flux linkage of the rotor; and

supplying the second command current to the stator.

6. The method of claim **5**, wherein the harmonic component is has a third harmonic frequency.

7. The method of claim **5**, wherein the amplitude of a current having the harmonic component is five to twenty percent of the amplitude of a current having the fundamental frequency.

8. A method of operating a multi-phase induction motor drive, the method comprising:

supplying to a motor having at least five phases a first command current to power the motor, the first command current having a fundamental frequency and the motor comprising a stator and a rotor;

determining, for each phase, at least one harmonic component of a signal indicative of the fundamental frequency;

generating a second command current from the harmonic component and the fundamental frequency, wherein the harmonic component and the fundamental frequency is generated by transforming currents having the harmonic component and the fundamental component from a coordinate system defined by the rest frame of the motor to a coordinate system defined by the q-axis of the rotor; and

supplying the second command current to the stator.

9. A method of operating a multi-phase induction motor drive, the method comprising:

supplying to a motor having at least five phases a first command current to power the motor, the first command current having a fundamental frequency, the motor comprising a stator and a rotor, the stator comprising a plurality of stator windings having substantially concentrated windings;

determining, for each phase, a harmonic component of a signal indicative of the fundamental frequency, the harmonic component having a frequency that is a third harmonic frequency of the fundamental frequency by: determining an electromagnetic torque of the motor; generating the fundamental frequency and the harmonic component from the electromagnetic torque; determining a flux linkage of the rotor; and generating the fundamental frequency and the harmonic component from the flux linkage;

generating a second command current from the fundamental frequency and the harmonic component;

measuring a current from the motor to determine a current error;

adjusting the second command current according to the current error;

supplying the second command current to the stator; and inducing a flux density in an air gap, the flux density having a substantially rectangular-shape, the air gap substantially between the rotor and the stator.