



47<sup>TH</sup> TURBOMACHINERY & 34<sup>TH</sup> PUMP SYMPOSIA  
HOUSTON, TEXAS | SEPTEMBER 17-20, 2018  
GEORGE R. BROWN CONVENTION CENTER

## API HIGH SPEED BALANCING ACCEPTANCE CRITERIA AND PEDESTAL DYNAMICS

### **Qingyu Wang**

Mechanical Engineer  
Elliott Group  
Jeannette, Pennsylvania

### **Brian Hantz**

Mechanical Engineer  
Elliott Group  
Jeannette, Pennsylvania

### **Brian C. Pettinato**

Mechanical Engineer  
Elliott Group  
Jeannette, Pennsylvania



*Qingyu Wang is a Mechanical Engineer at Elliott Group in Jeannette, Pennsylvania. He has been with Elliott Group since 2005. His areas of expertise include lateral and torsional rotordynamics. He received his B.S. and M.S. both in Mechanical Engineering from Tsinghua University, 1997 and 2000 respectively. He received his Ph.D in Mechanical Engineering from the University of Virginia, 2008. He serves on the API 684 rotordynamics task force, and is a member of ASME.*



*Brian Hantz is a Mechanical Engineer at Elliott Group in Jeannette, Pennsylvania. He has been with Elliott Group since 2014. His areas of expertise include vibration and modal testing. He received his B.S. in Aerospace Engineering from Penn State University in 2012. Prior to joining Elliott Group, he worked as a dynamics engineer at Sikorsky Aircraft Corporation.*



*Brian C. Pettinato is Manager of Product Development at Elliott Group in Jeannette, Pennsylvania. He has been with Elliott Group since 1995. His areas of expertise include lateral and torsional rotordynamics, vibration analysis, and the testing and evaluation of fluid film journal bearings. He currently manages a group responsible for compressor and expander technology development. Prior to joining Elliott Group, Mr. Pettinato worked as a project engineer for an aftermarket bearing manufacturer. Mr. Pettinato received his B.S. (Mechanical Engineering, 1989) and M.S. (Mechanical Engineering, 1992) degrees from the University of Virginia. He has coauthored over ten technical papers, and holds one U.S. patent. He is a registered Professional Engineer in the State of Pennsylvania. He serves on the API 684 rotordynamics task force, and is a member of both ASME and STLE.*

## ABSTRACT

Acceptance criteria for high-speed balancing of turbomachinery are specified in API standards based on either pedestal velocity or shaft displacement, and these are discussed in detail. Pedestal velocities are measured using velocimeters located at each pedestal whereas shaft displacements are measured using eddy-current probes adjacent to each bearing.

In addition to performing balancing, the measured displacements can also be used for verification of the unbalance response analysis. Since the pedestals are relatively soft, their dynamics need to be considered in the analysis. In this paper, multiple modal tests are conducted on 3 different pedestals: DH4, DH7, and DH70. The FRFs are parameterized to be used in a rotordynamic model. Different torques on the pedestal bolts are used to study the effect on the measured FRFs. The added-mass method is applied to DH7 pedestals

with a 220 pound plug in the pedestal bore. The calculated modal mass and stiffness are compared to values identified from the measured FRFs. Unbalance verification of some shop orders is compared to the predictions with different ways of characterizing the pedestal dynamics: rigid, mass and stiffness, and the FRFs. Minor improvements are observed using the measured data comparing to the original models and further areas of improvement are identified.

## INTRODUCTION

High speed balancing, also known as operating or at-speed balancing, is often recommended for machines operating above their first critical speed. The rotor is supported on bearings which are mounted on pedestals. The pedestals must be relatively flexible to allow sufficient response to rotor unbalance. The high-speed balance acceptance criteria is dependent on the API standard and edition. One set of criteria is provided in API 612 7<sup>th</sup> edition in which the pedestal velocity is based on the pedestal stiffness. Accurate pedestal stiffness is necessary to meet the intent of the criteria.

Aside from performing balancing, a high-speed balance facility can also be used for unbalance response verification. In this case, it would be ideal to have the support (bearings and pedestals) the same as the field conditions; however, there are always differences between the support stiffness of the balancing facility, the test floor and the site. Even between different balancing facilities, there could be large differences.

As an example, *Figure 1* shows the Bode plot from Balancing Facility 1 (shut-down), and *Figure 2* shows the Bode plot of the same rotor from Balancing Facility 2 (both startup and shut-down). The rotor was balanced in Facility 1 and then shipped to Facility 2. At Facility 2, there was no balancing done, i.e. no changes made to the rotor. Both facilities have shop tilting-pad journal bearings, i.e. same type, but different bearings.

From this example, it can be seen that both the magnitude and the locations of the peaks are different. Note that the format and scale are different. Since there is no change of the rotor, the difference has to come from the support system (bearings, pedestals and foundation), and pedestal dynamics has to be considered as a major contributor to the difference.

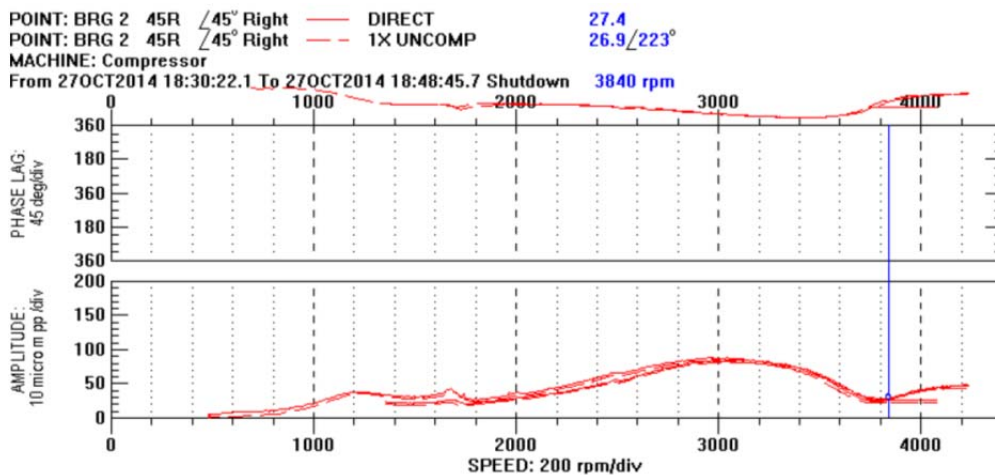

*Figure 1: Bode plot from Balancing Facility 1*

Note that in both figures, there seem to be two critical speeds, but the rotordynamics analysis (assuming rigid structural support behind the bearings) shows only one. There are sometime concerns regarding the second critical speed, because by design (for the field condition) it should not appear. So in those cases where the second critical speed does appear, a proper explanation is required, which is best provided by an accurate prediction. This requires an accurate pedestal model. The stiffness of the pedestal will lower the effective support stiffness. This softening of the support will decrease the frequency of the mode and place it in the operating speed range. To analyze the impact of the support stiffness on the critical speed location, accurate characterization of the pedestal dynamics is needed.

There are different ways to characterize the pedestal dynamics. A simple way is to use mass and stiffness. Usually the original pedestal manufacturer (Vendor) will provide the values, and these values are used in the balancing criteria and rotordynamic analysis. Another way is to use Frequency Response Functions (FRFs). There are numerous papers presenting the rotordynamic analysis with pedestal/support FRFs, such as Nicholas et al. (1986), Stephenson and Rouch (1992) or Vazquez et al. (2001). There are also reports

of the pedestal FRFs in the Balancing Facility being measured, such as Zhou (2013). However, to the authors' knowledge, there is no publication of the FRFs from Balancing Facility being used in the rotordynamic analysis. It appears that using the pedestal FRFs would improve the rotordynamics predictions, so the authors initiated a campaign of acquiring accurate FRFs for all the pedestals, in hope of verifying the Vendor provided data and improving the predictions.

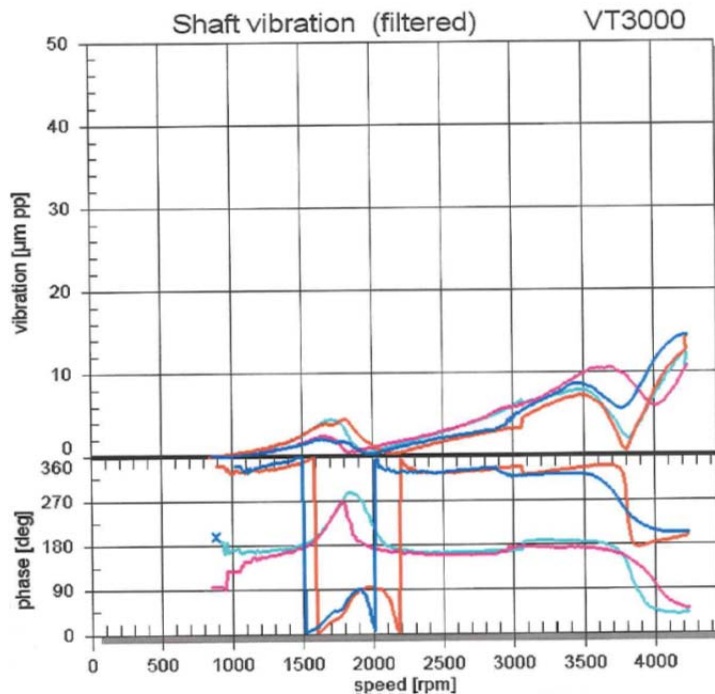

Figure 2: Bode plot from Balancing Facility 2

## API BALANCING ACCEPTANCE CRITERIA

### Summary of Balancing Criteria

Table 1 summarizes the high-speed balancing criteria from the API standards reviewed. Note that the table does not distinguish between “shall” or “if specified”.

Table 1. API Balancing Criteria Summary

API No.	Application	Edition	Acceptance Criteria	
			High Speed	Low Speed
API 611	General Purpose Steam Turbines	5 <sup>th</sup> (2008)	MA	API
API 612	Special-Purpose Steam Turbines	6 <sup>th</sup> (2005)	V1	API
		7 <sup>th</sup> (2014)	V1, V2, D1	
API 613	Special Purpose Gear	5 <sup>th</sup> (2003)	None	API
API 616	Gas Turbines	5 <sup>th</sup> (2011)	V3	API
API 617	Axial and Centrifugal Compressors and Expander-compressors	7 <sup>th</sup> (2002)	V1	API
		8 <sup>th</sup> (2014)	MA	
API 672	Packaged, Integrally Geared Centrifugal Air Compressors	4 <sup>th</sup> (2004)	OEM	OEM
API 684	Rotordynamics Tutorial	2 <sup>nd</sup> (2005)	V2	API
API 687	Rotor Repair	1 <sup>st</sup> (2001)	V1	API

The abbreviations are explained as follows.

API – the maximum allowable low speed residual unbalance is specified as

In SI units:

$$U = 6350 \frac{W}{N} \quad (1)$$

In US units:

$$U = 4 \frac{W}{N} \quad (2)$$

where

$U$  is the residual unbalance in g-mm (oz-in)

$W$  is the bearing static load in kgf (lbf)

$N$  is the maximum continuous speed in rpm

D1 – the maximum allowable shaft vibration (1X filtered and runout compensated) shall not exceed 1.0 mil peak-to-peak at any response or 0.5 mil peak-to-peak over operating speed range for probes near the bearings.

MA – mutually agreed

OEM – Manufacturer’s standard balancing procedure

V1 – For all speeds at or less than 3000 rpm, the pedestal vibration shall not exceed 2.5 mm/s (0.098 in/s) RMS. For speeds above 3000 rpm, the pedestal vibration shall not exceed the calculated value of  $(7400/N)$  mm/s  $((291/N)$  in/s) or 1 mm/s (0.039 in/s) RMS, whichever is the greater, where  $N$  is the maximum continuous speed in rpm. The criterion applies to the major axis velocity.

V2 – velocity calculated such that the maximum allowable unbalance force at any journal at maximum continuous speed shall not exceed 10 percent of the static loading of that journal.

V3 – the acceptance criterion, only used in API 616, 5<sup>th</sup> edition, is a combination of residual unbalance and pedestal vibration.

### Discussion

In the early API standards, balancing was not a major part, and there were no criteria. Later on, low speed balancing criteria were added for most standards, but high speed balancing criteria only existed in certain standards. For certain types of machines, such as motors, gears, or couplings, the operating speed is in general below the first critical speed, and no high speed balance required.

The low speed criteria had always been a form of unbalance amount with some variations. In current standards, Equation (1) for g-mm or (2) for oz-in is predominantly used. ISO standards use Grade, which limits the velocity of the cg (center of gravity) of the rotor, and they are essentially the same as the API standards: the  $4W/N$  API standard is equivalent to ISO Grade 0.7 (API 684, 2<sup>nd</sup> edition, Paragraph 5.2.7). Note that the limit of the unbalance amount (or eccentricity of cg) has the assumption that the rotor can be simplified as a single mass.

For high speed balancing, since the rotor cannot be simplified as a single mass, limiting the unbalance amount cannot be used directly. An alternative, the V2 method (appeared first in API 617 4<sup>th</sup> edition) is to limit the force induced by the unbalance. The 10% of the static weight was suggested by Jackson (1979).

There are some variations of the format, such as API 612, 7<sup>th</sup> edition, API 616 2<sup>nd</sup> edition and API 684 2<sup>nd</sup> edition, but essentially they are all the same as the V2 method.

The V1 method for high speed balancing is only related to the operating speed, and it could be largely different compared to the V2 method. With 723 shop orders from the authors’ company, the relationship between V1 and V2 is shown as *Figure 3*, where the red line is the V1 method, and all the dots are calculated based on V2 method (0.2 ‘g’, i.e. 10% static load per pedestal) using Maximum Continuous Speed (MCS), rotor weight and pedestal stiffness. The stiffness values used are Vendor provided:  $3.2 \times 10^6$  lb/in for DH4 and  $7.62 \times 10^6$  lb/in for DH7.

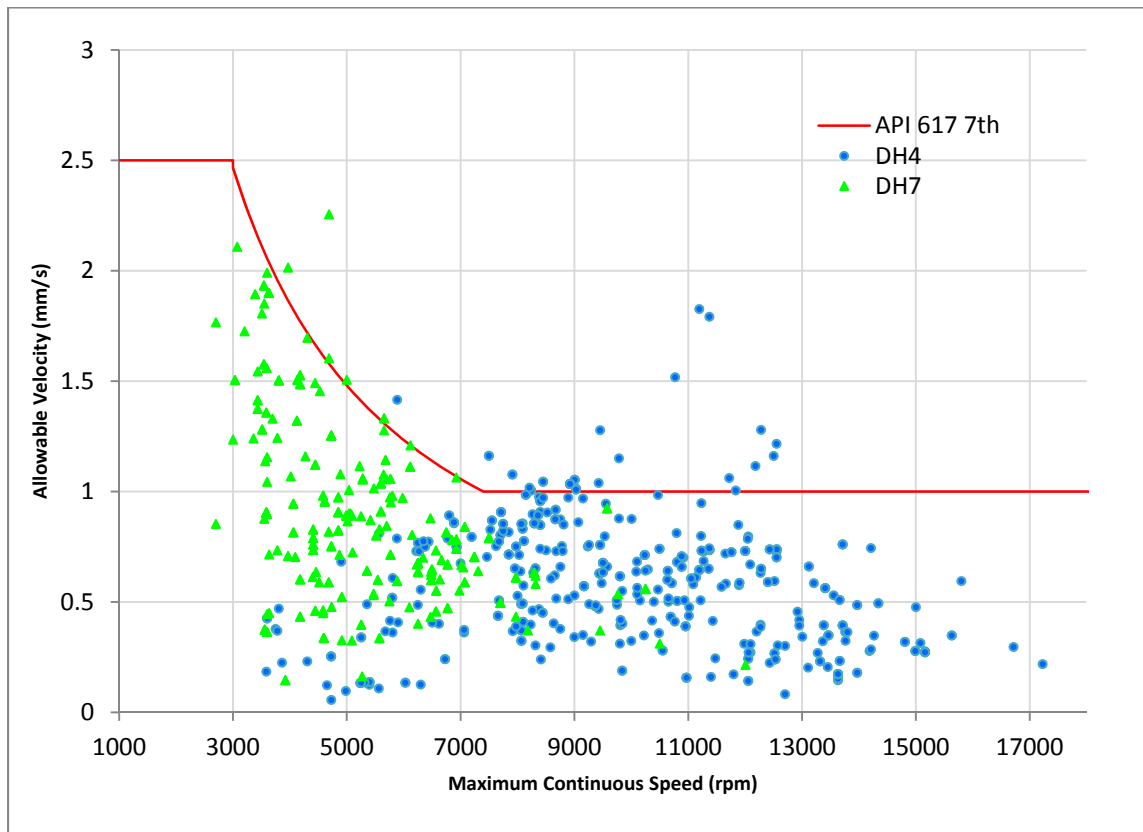

Figure 3: MCS vs. Allowable Velocity with shop order data

For some of the V1 criteria, such as API 687, 1<sup>st</sup> Edition, velocity “measured on the bearing cap” is also specified. This might be difficult to comply with because the velocimeters are often located (built-in) below the bearing housing in the pedestals.

D1, the displacement criteria, is only used in API 612, 7<sup>th</sup> edition, and it is similar to the criteria used in shop tests (or test floor tests), only tighter. The commonly used shop tests acceptance criteria are in the following format (English):

$$A = \sqrt{\frac{12000}{N}} \quad (3)$$

where

$A$  is amplitude (mil)

$N$  is the maximum continuous speed, in rpm

The vibration amplitude (unfiltered) measured by any probe (of the four) should not exceed  $A$  or 1 mil within the operating speed range.

Comparing to the shop test acceptance criteria, D1 is using the 1X filtered data, which are smaller than the unfiltered values, but the 1 mil limit at any response might be difficult to comply with at the first critical speed and trip speed. The 0.5 mil limit for the operating range is a reasonable target to try, but it might not be achievable in some instances. For example, the support stiffness might lower the second critical speed into the operating speed range.

Although both velocity and displacement measurements are available in balancing facilities, the velocity measurement is usually used for balancing and balancing criteria because of the relative stable situation: the velocimeters are built-in within the pedestals so the quality of measurement stays the same regardless the rotor being balanced. The eddy-current probes might be shifted depending on the rotor and bearing combination. Sometimes the probes might not even be at a burnished area.

If the probe location at the balancing facility is different from the actual machine location due to the bearing housing configuration, a multiplier can be used to adjust the acceptance criteria as suggested in ISO 11342, Section 8.2.5. The value of the multiplier can be derived by comparing the vibration amplitudes at the two locations by doing rotordynamic analysis (note that the value depends on the

rotor modal characteristics and speed, so it needs to be established for each specific application). If the probes are not at the burnished area, the quality of the measurement could be too poor to be useful.

## PEDESTAL DYNAMICS

Originally, an outside consulting firm (Consultant) was brought in to perform these modal tests to obtain improved pedestal transfer functions. However, after repeating the test with Elliott equipment, the pedestal responses did not agree within expectations. *Figure 4* and *Figure 5* show examples of the differences seen on the DH4 pedestals. Large differences in peak location and amplitude were also seen on the DH7 pedestals. It is important to note that Consultant was not asked to perform measurements at several pedestal locations along the rails, or to troubleshoot any pedestal setup, despite the knowledge that this could have an impact on measurement repeatability. The original report provided by Consultant included the pedestal locations for all measurements for this reason, as any troubleshooting of the bunker setup and repeatability was the responsibility of Elliott.

The labels for the FRF directions indicate the measurement direction and the direction of the hit, in that order. For example, the “XY” measurement indicates a response measured in the horizontal (X) direction due to an impact in the vertical (Y) direction.

Each pedestal has additional hydraulically actuated stiffening devices. These auxiliary supports are parallel to the main supports and provide additional stiffness when activated. This is referred to as the “stiffening on” setting, whereas the “stiffening off” setting refers to the base pedestal stiffness without auxiliary support.

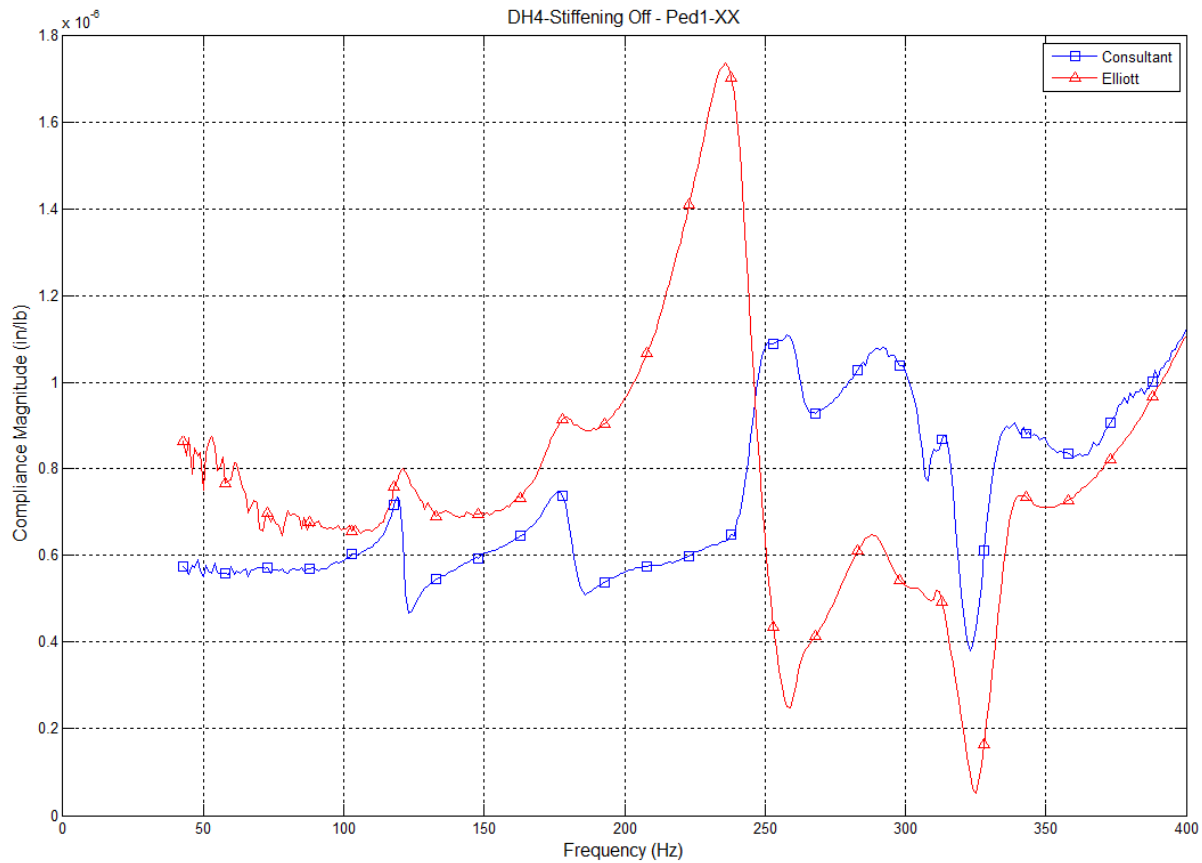

*Figure 4: Consultant vs Internal compliance measurements on DH4 pedestal 1 – stiffening off – XX*

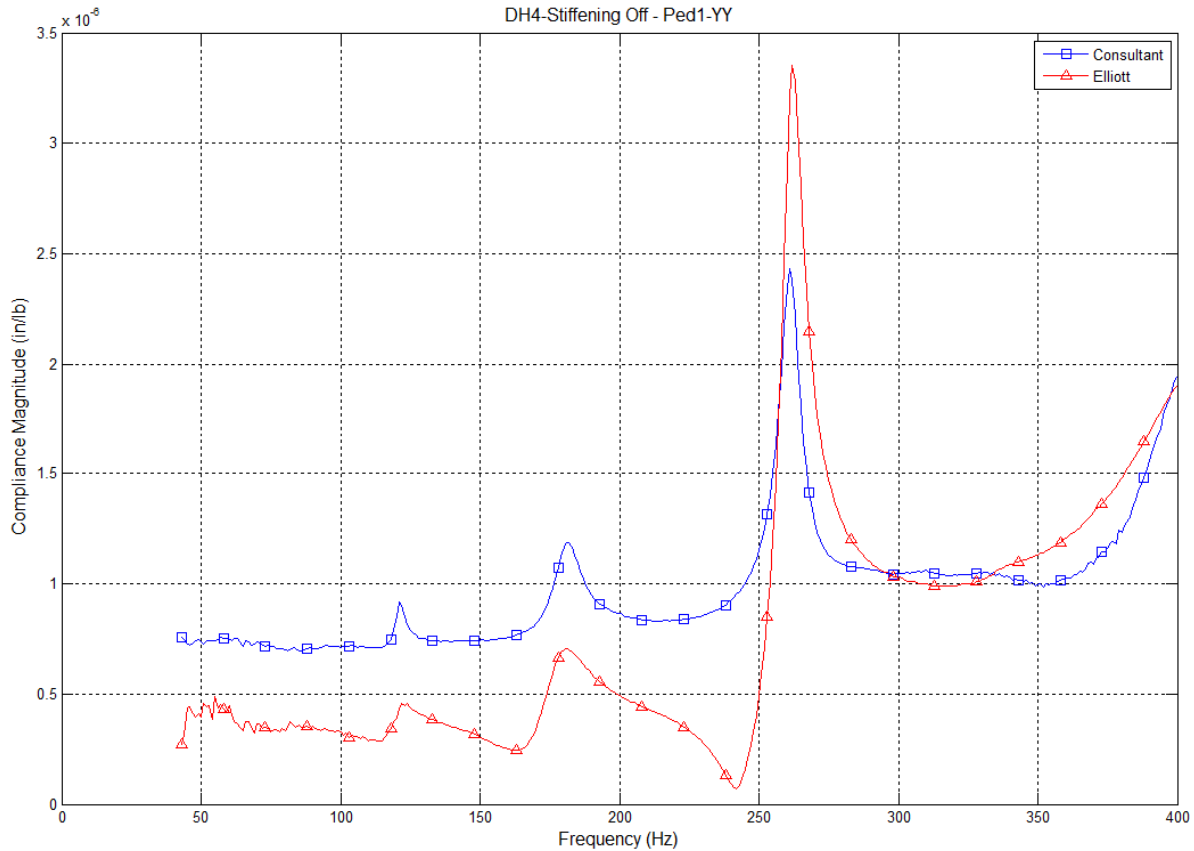

Figure 5: Consultant vs Internal compliance measurements on DH4 pedestal 1 – stiffening off – YY

These disagreements forced an investigation into the root cause of the inconsistent pedestal measurements, as detailed next.

#### Investigation of Modal Testing Inconsistencies

A series of steps were performed to determine the root cause of the discrepancies. For convenience, all investigations were performed with the pedestal stiffening off:

1. All Elliott modal testing equipment was calibrated. The test reports provided by Consultant included up to date calibration sheets.
2. FRFs were collected after the pedestals were moved along the rails at various positions, to determine the effect of pedestal position.
3. A full modal test was performed on the rails to determine if the rail stiffness was influencing the pedestal dynamics.
4. FRFs were collected while the pedestals were lifted and dropped multiple times in the same location. This was to determine if the pedestal placement was inconsistent.
5. FRFs were collected with various torque levels used on the pedestal bedbolts to determine if the bedbolt torque changed the pedestal dynamics.
6. FRFs were collected with different torque levels used on the bearing cap bolts to determine if the bearing cap bolt torque changed the pedestal dynamics.



Figure 6 shows the effect of moving the pedestals along the rails and repeating the measurements, while using the same equipment and setup for each measurement. The results show the pedestal dynamics changed significantly as the pedestals were moved. The legend indicates the distance (inches) of each pedestal to the end of the rails on the drive-end. At the time, it was not clear whether the location of each pedestal would affect the results as cross-talk between the two pedestals, so the locations of both pedestals are recorded (P1 as pedestal 1, and P2 as pedestal 2).

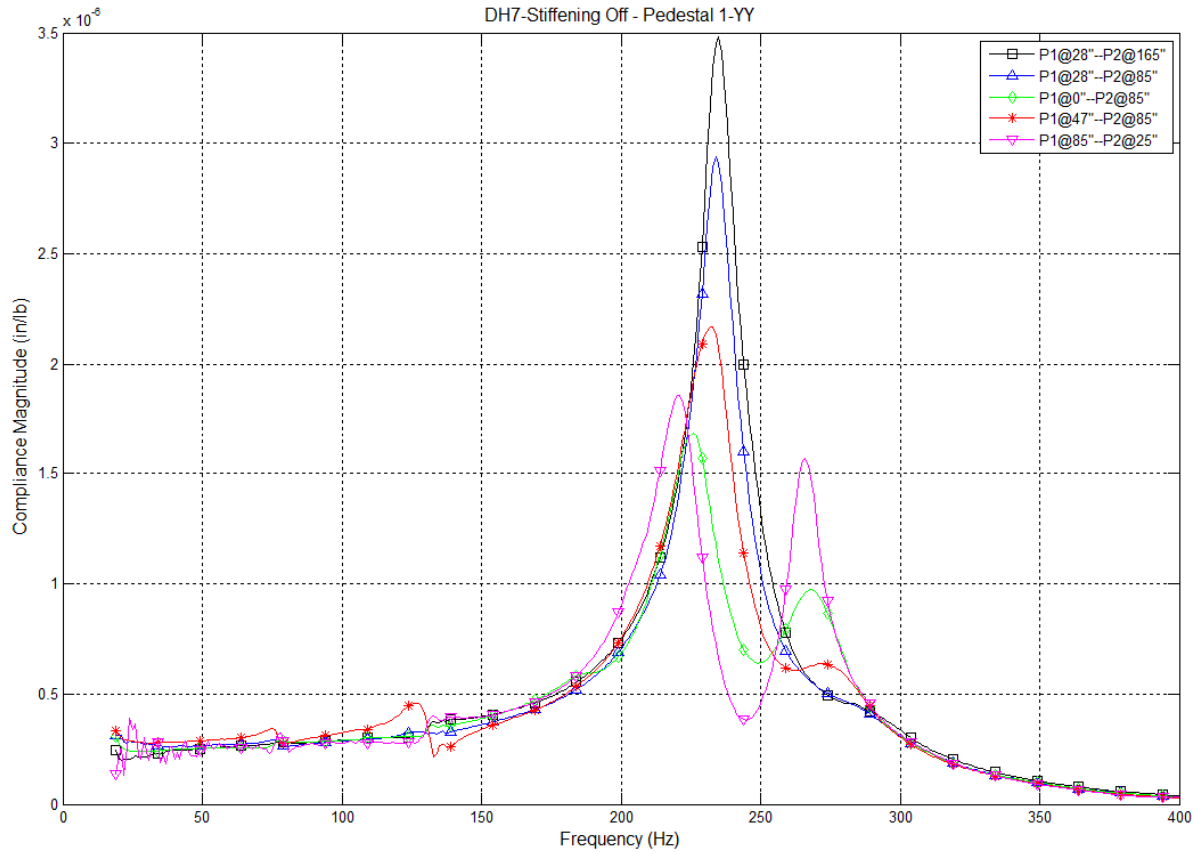

Figure 6: DH7 pedestal response at various rail locations (YY)

To determine if the rails were interfering with the pedestal responses, a full modal test of the rails was performed. All pedestals were removed from the bunker during this test. No coherent response could be measured in the frequency range of interest using a 2 pound impact modal hammer, so it is believed that the rails were stiff enough and should not be interacting with the pedestal modes.

Figure 7 shows compliance measurements after lifting and repositioning the pedestal multiple times in the exact same location. This was to determine whether the act of lifting and placing the pedestal had any effect, which would indicate inconsistencies when securing the pedestals in place. Significant differences in pedestal response are apparent, particularly in the vertical direction, indicating that pedestal placement was inconsistent in some manner.

After acquiring all the confusing results, finally the torque on the bedbolts (the bolts that hold the pedestals to the rails) became the primary suspect. The bolts had been tightened “as tight as possible” by the operators, as no torque wrench was used in the past. A torque wrench was used for the following study, and the pedestal bedbolts were torqued to various levels. FRF measurements were taken at each torque level to document the different pedestal response to varying bolting torque. The pedestals were not moved throughout the entire test to rule out all other possibilities. An example of the results in Figure 8 indicates that bolting torque has a significant impact on pedestal response.

It is interesting to note that using a torque wrench significantly reduced the amplitude of the second vertical mode at approximately 275 Hz, for all the torques used. It is possible that this mode is influenced by inconsistent bolting torque between each bolt, rather than an overall torque used for all bolts. When operators tighten bolts by hand, the bolting torque can vary significantly across all bedbolts,



whereas a torque wrench provides much greater consistency for each bolt on the pedestal.

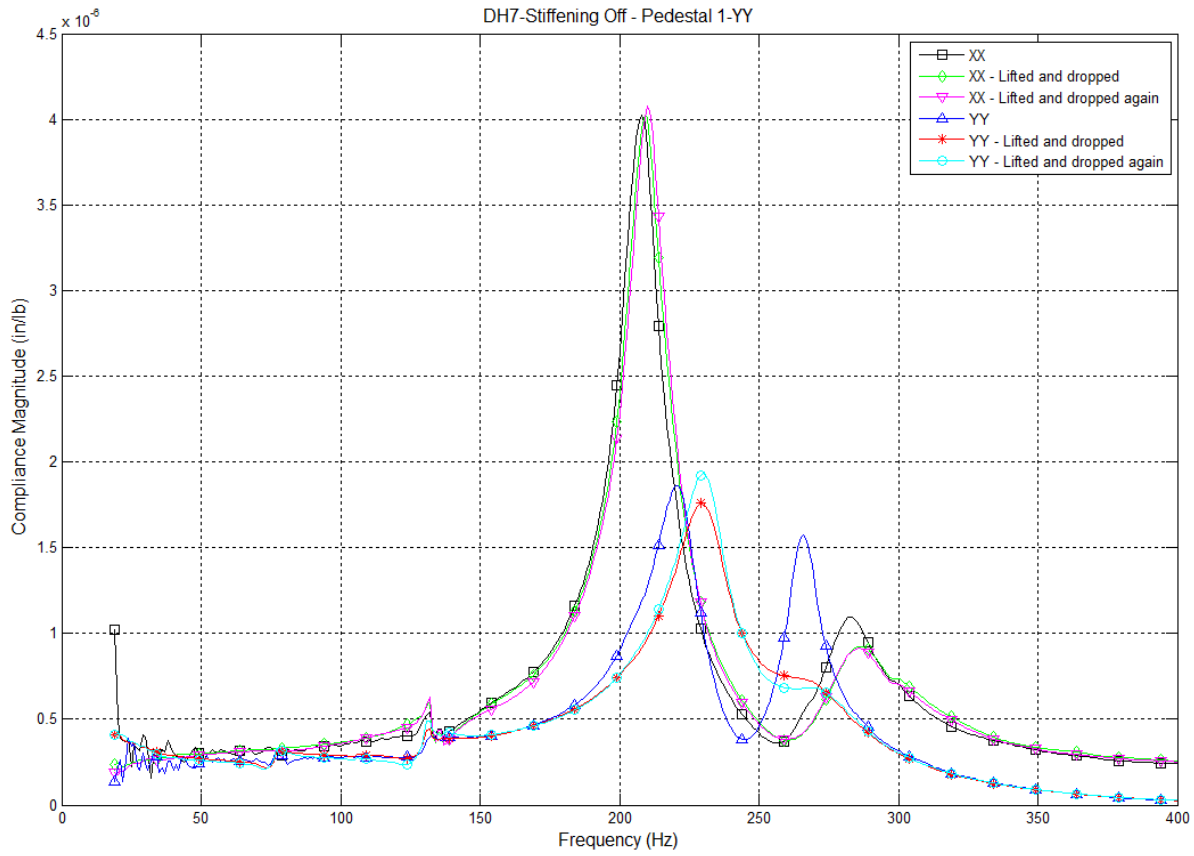

Figure 7: Effect of pedestal placement on FRF measurements

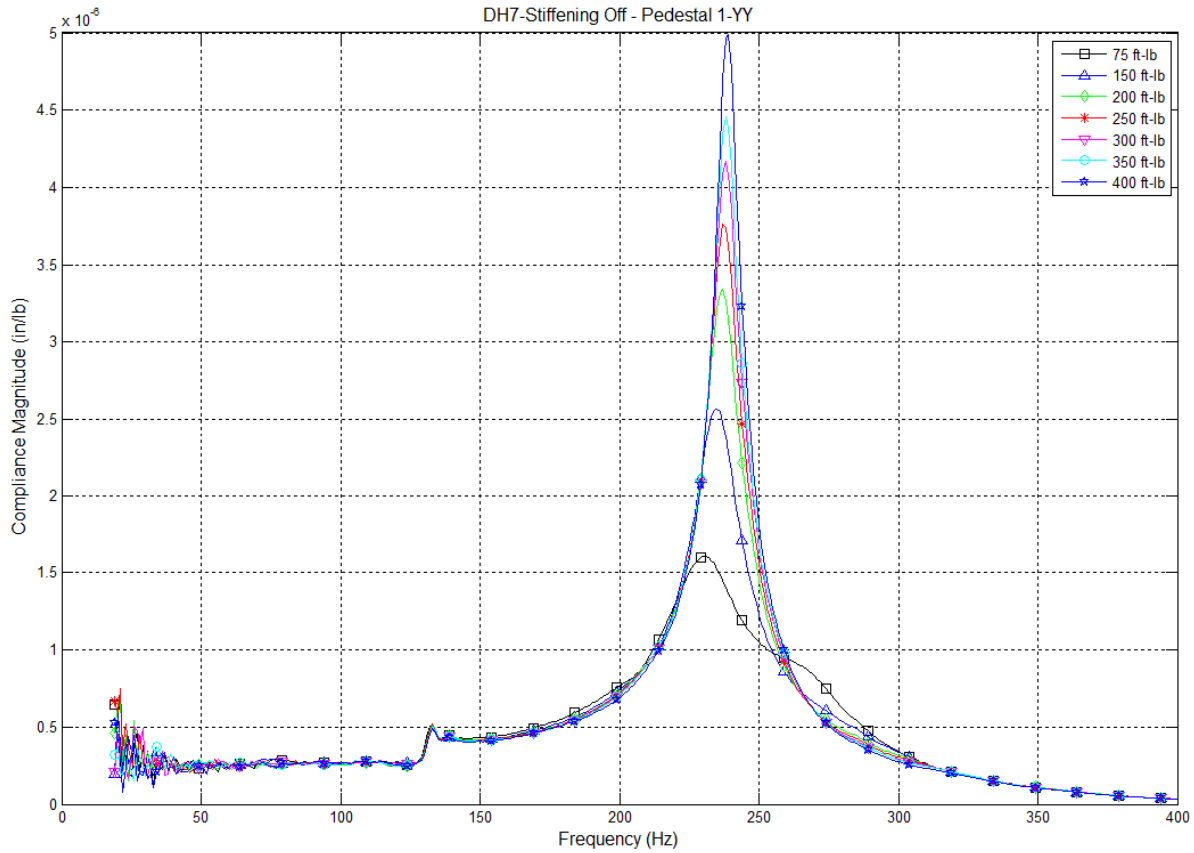

Figure 8: DH7 pedestal response to varying bedbolt torque (YY)

As an additional check, the pedestals were moved to various locations while keeping the bolting torque consistent. A bolting torque of 250 ft-lb was used for all pedestal locations. *Figure 9* confirms that a consistent bolting torque greatly improves repeatability of measured FRFs, regardless of pedestal location. As a comparison, a loosened case is also presented in the figure as the red-asterisked line.

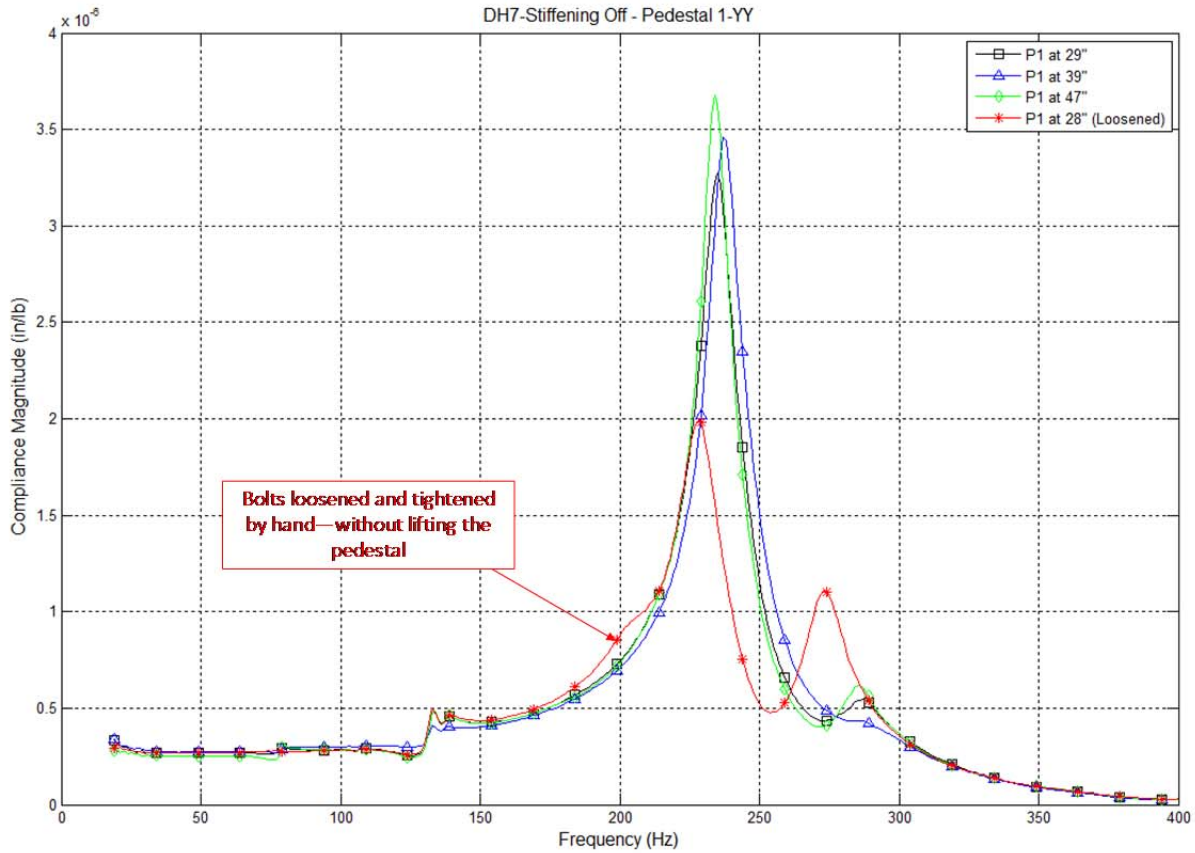

Figure 9: DH7 pedestal response at various rail locations with consistent bedbolt torque (YY)

Figure 10 shows a DH7 pedestal response with loosened and tightened bearing caps. At the time, a torque wrench for the bearing cap bolts was not available; therefore this was only a qualitative assessment. The results indicate that the bearing cap bolting torque presents a negligible impact on the pedestal response in the frequency range of interest. This test was repeated on the DH4 pedestals with similar results.

Although the bearing cap bolting torque does not appear to introduce any significant differences in compliance measurements under the test conditions, this was only a cursory assessment. The cap bolts may impact overall stiffness during operation and should always be tightened to the designed torque.

#### Alternate DH4 Impact Location

As an additional study into the effects of hammer impact location, FRFs were collected for the DH4 pedestals with an alternate horizontal impact location. The original impact location was directly next to the bearing location. The impact locations are shown in Figure 11. This alternate location was chosen because it should not introduce any axial / yaw excitation that can occur due to limited impact space near the bearing location.

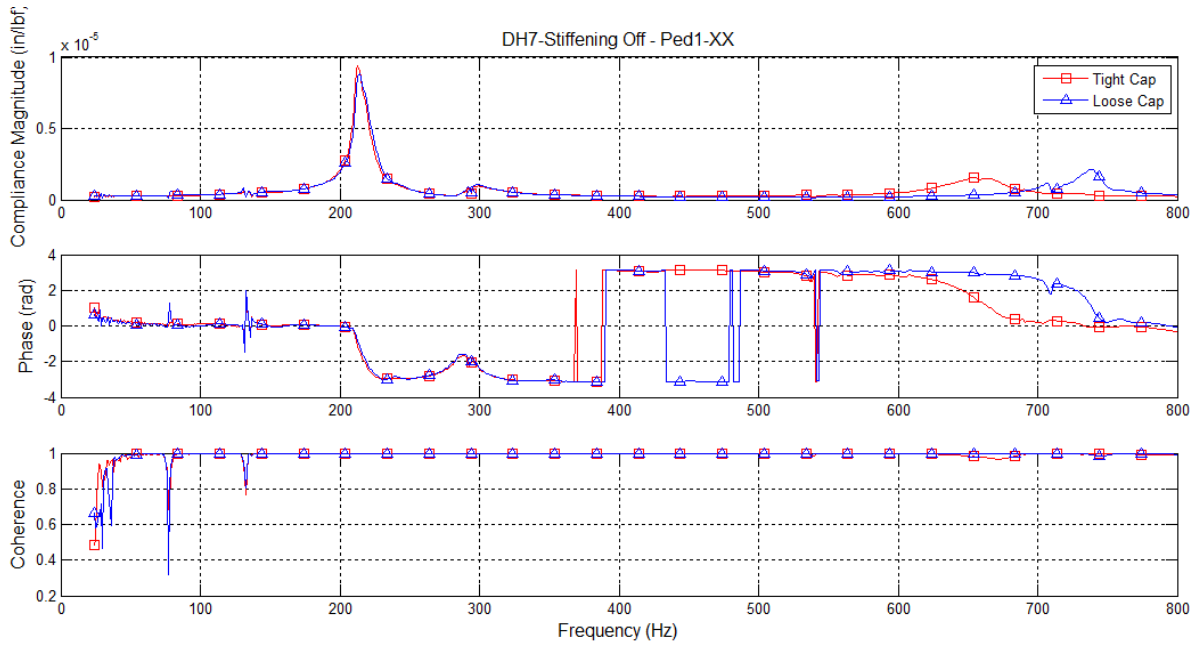

Figure 10: Effect of loosened bearing cap bolts on DH7 pedestal 1 (XX)

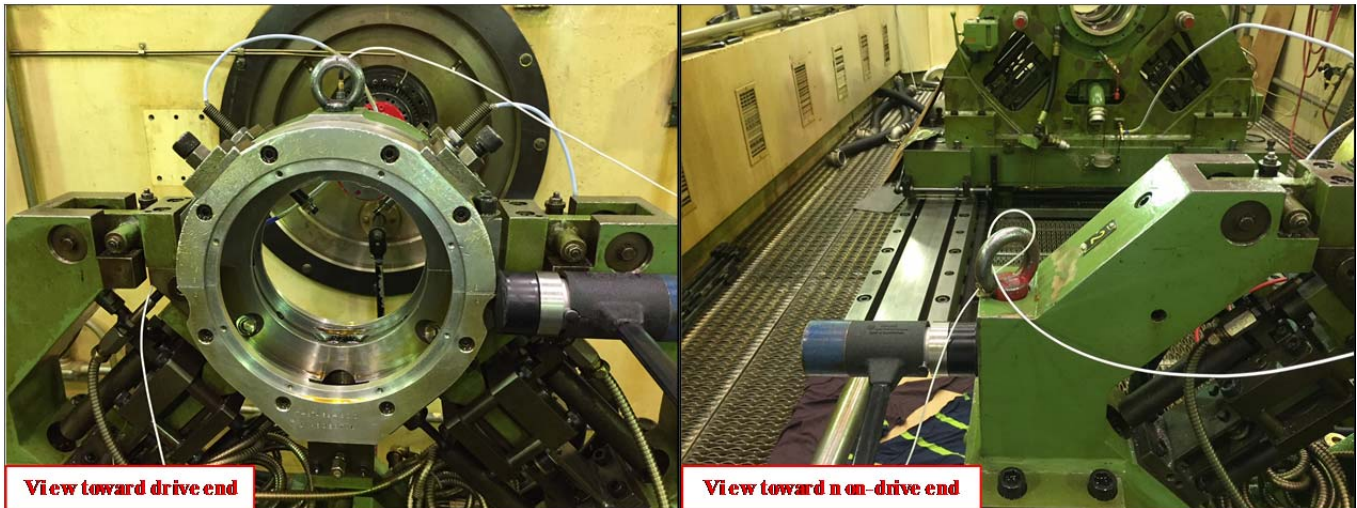

Figure 11: Original impact location (left) and alternate horizontal impact location (right) for DH4 pedestals

The horizontal responses measured from this alternate impact location for stiffening-off are provided in Figure 12. The vertical direction and stiffening-on cases show similar discrepancies: while this location successfully removes the low frequency axial mode excitations, the compliance magnitude is approximately an order of magnitude lower. Therefore, an impact excitation far away from the bearing location is not recommended for modal tests, as the pedestal stiffness could be greatly overestimated.

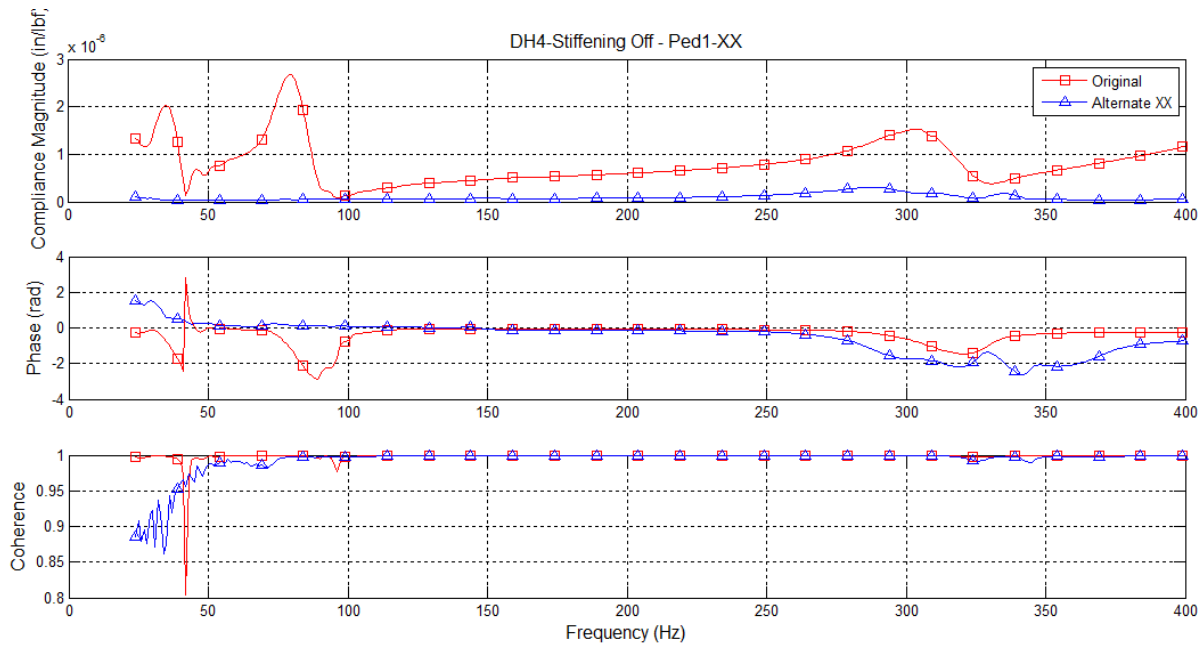

Figure 12: Response comparison to alternate impact location - DH4 - stiffening off - pedestal 1 - XX

The investigations presented previously explore several possibilities to explain the measurement inconsistencies seen for the pedestals. The results indicate that the most important parameter to have a consistent result is the torque of the bedbolts, and the torque could be quite inconsistent even if the operators might feel otherwise. While there may be other contributing factors in inconsistent measurements (e.g. pedestal cross-talk), the inconsistent bedbolt torque has been demonstrated to be a major factor driving inconsistent modal test results. A pneumatic torque wrench was then obtained and used for further tests and balancing, and 600 ft-lb bed bolt torque suggested by the Vendor for DH70 is used for all pedestals.

#### Pedestal Original Manufacture (Vendor) Tests

The Vendor has come to the Balancing Facility and performed both FRF measurement and shaker test. The shaker test (the shaker assembly is used in the pedestal bore) is to obtain low frequency stiffness, and the natural frequencies are measured with a supplemental impact hammer test.

Table 2: Single mass models provided by Vendor

	Stiffening Off			Stiffening On		
	<i>m</i>	<i>c</i>	<i>k</i>	<i>m</i>	<i>c</i>	<i>k</i>
	<i>lbm</i>	<i>lb.s/in</i>	<i>lb/in</i>	<i>lbm</i>	<i>lb.s/in</i>	<i>lb/in</i>
DH4 PED1 - XX	44.1	10.0	1.43E6	44.1	10.0	3.20E6
DH4 PED1 - YY	44.1	10.0	1.43E6	44.1	10.0	3.20E6
DH4 PED2 - XX	44.1	10.0	1.43E6	44.1	10.0	3.20E6
DH4 PED2 - YY	44.1	10.0	1.43E6	44.1	10.0	3.20E6
DH7 PED1 - XX	770.0	10.0	5.08E6	770.0	10.0	7.62E6
DH7 PED1 - YY	770.0	10.0	5.08E6	770.0	10.0	7.62E6
DH7 PED2 - XX	770.0	10.0	5.08E6	770.0	10.0	7.62E6
DH7 PED2 - YY	770.0	10.0	5.08E6	770.0	10.0	7.62E6
DH70 PED1 - XX	1785.7	10.0	6.67E6	1785.7	10.0	1.30E7
DH70 PED1 - YY	1785.7	10.0	6.67E6	1785.7	10.0	1.30E7
DH70 PED2 - XX	1774.7	10.0	6.67E6	1774.7	10.0	1.35E7
DH70 PED2 - YY	1774.7	10.0	6.67E6	1774.7	10.0	1.35E7

The modal mass is calculated using the low frequency stiffness and location of the peak from the FRFs. The provided modal mass (*m*),

damping ( $c$ ), and stiffness ( $k$ ) are list in *Table 2* for all pedestals. Note that horizontal and vertical are considered the same, and no cross-coupling stiffness or damping is considered. A minimal value has traditionally been assumed for damping since the raw FRF data is not provided by the Vendor.

An example of the shaker test result from the Vendor report is shown in *Figure 13*. The authors were not successful in acquiring the raw FRFs from the Vendor.

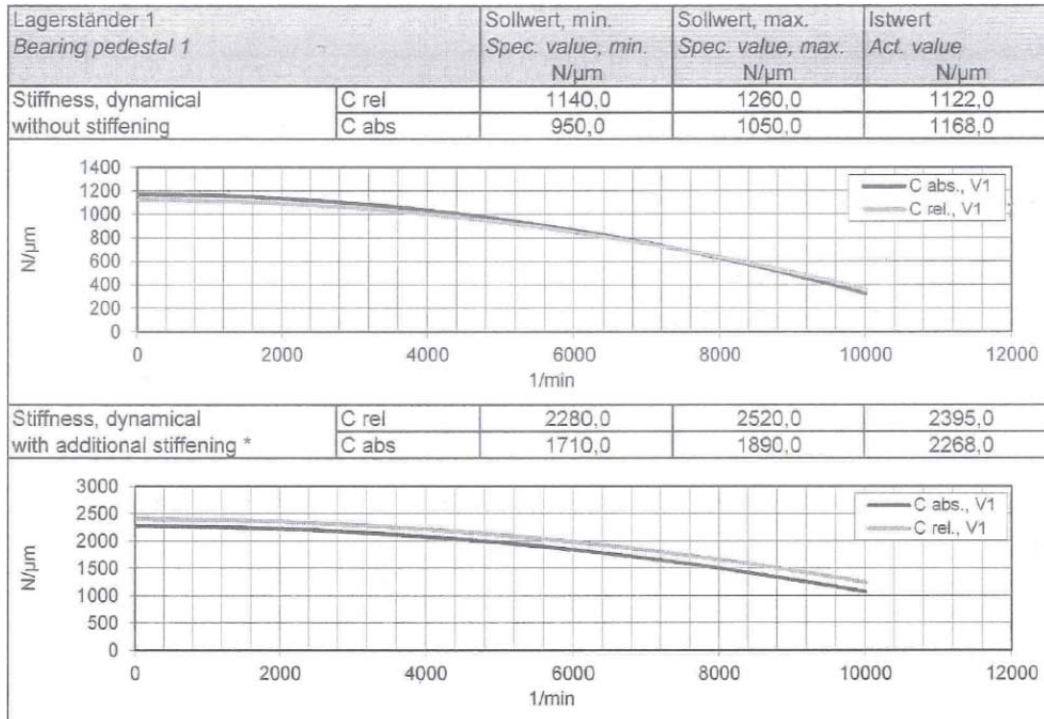

*Figure 13: DH70 shaker test*

#### *DH7 Added-mass Test*

The added-mass method (see Appendix A for details) can be used in the field or the test floor to check the pedestal stiffness, where the bearing cap often serves as the additional mass. For this study, a plug weighing 220 pounds as shown in *Figure 14* was machined for the DH7 pedestal to create enough shift of the first critical speed / natural frequency.

As an example of the test results, the horizontal direction of stiffening-off case is shown in *Figure 15*. The calculation results are summarized in *Table 3*. The comparison will be carried out later together with other test results.

*Table 3: Plug test results for DH7 pedestals*

	Stiffening Off			Stiffening On		
	$m$	$c$	$k$	$m$	$c$	$k$
	<i>lbm</i>	<i>lb.s/in</i>	<i>lb/in</i>	<i>lbm</i>	<i>lb.s/in</i>	<i>lb/in</i>
PED1 - XX	911.7	190.8	4.31E6	1235.0	330.3	6.62E6
PED1 - YY	685.9	96.3	4.01E6	1006.7	261.0	7.28E6
PED2 - XX	1035.2	204.2	5.03E6	1814.1	485.9	1.02E7
PED2 - YY	710.4	81.9	4.11E6	861.1	176.7	6.42E6



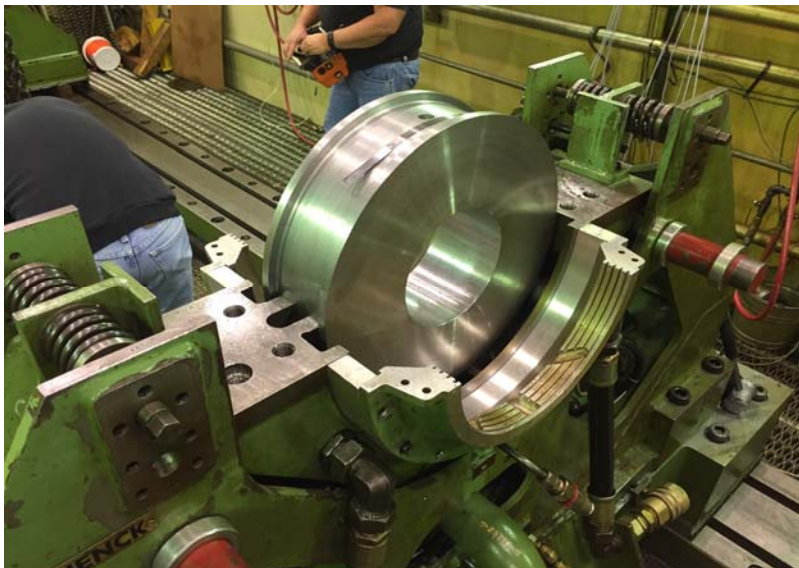

Figure 14: DH7 Pedestal Plug

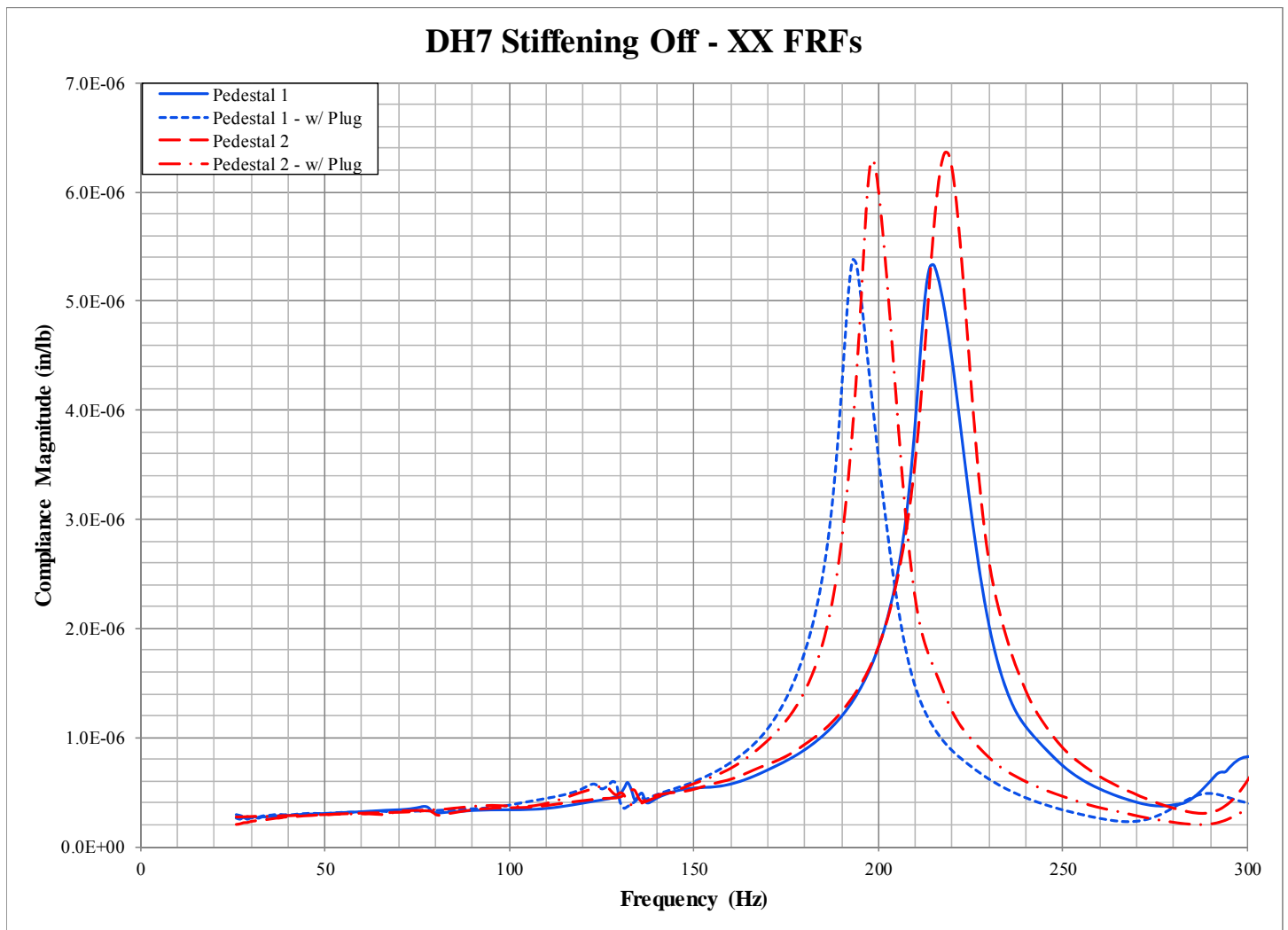

Figure 15: DH7 pedestal response with and without plug (XX, stiffening off)



### Modal Test Results

After all bolts were tightened to the specified values, modal measurements were performed for all pedestals with both stiffening on and off.

The modal test setup is similar for all pedestals, as shown in *Figure 16* (accelerometer locations) and *Figure 17* (hammer location). Inside of the bearing housing was also tried as the locations of the accelerometers and hammer, but no significant difference was found.

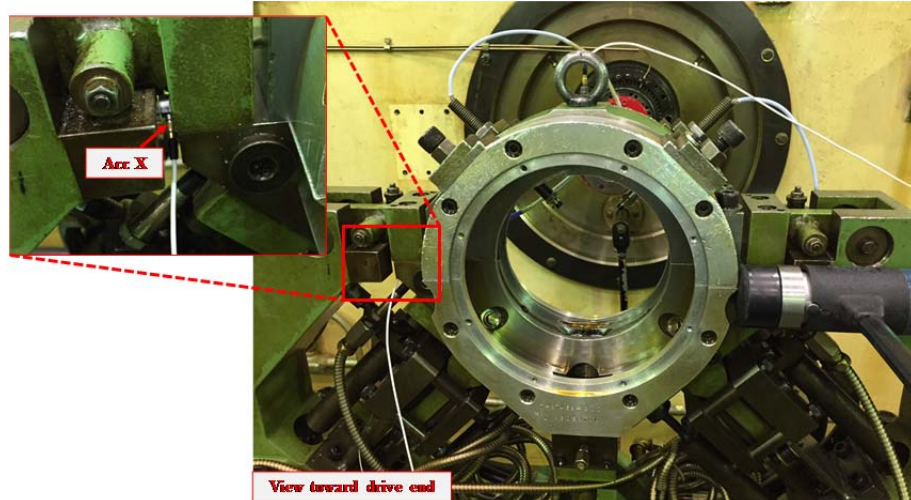

*Figure 16: DH4 Horizontal Impact Location and Accelerometer Placement*



*Figure 17: DH4 Vertical Impact Location and Accelerometer Placement*

Mode shapes were also collected to help identifying the frequencies. A tri-axial accelerometer was placed at the top of the bearing cap, and a roving hammer technique was used. The frequencies of these modes were used in identifying the peak of interest when creating SDOF models from the FRFs. Note that the frequency may shift slightly when stiffening is used.

The measurements were then parameterized (curve-fitted) as either a single degree of freedom (SDOF) system or a multiple degree of freedom (MDOF) system. The SDOF is ideal because it can be used to compare the mass, damping and stiffness provided by the Vendor or measured with the added-mass method, but it may not be appropriate when multiple peaks exist in an FRF. Appendix B details the methods of the curve-fitting of the FRFs.

## DH4 Pedestals

The modal parameters obtained for each direction are provided in *Table 4*, where the stiffness of the Vendor provided data are also presented as comparison. Note that because the peak for the YY direction is out of range of the measurement, the modal parameters (especially damping) cannot be identified accurately. Because the peak is out of range, the curve fitting will identify  $m$ ,  $c$ , and  $k$  values that adequately model below the peak, but may not represent the actual peak.

*Table 4: SDOF model of DH4 pedestals (curve-fit)*

	Stiffening Off				Stiffening On			
	$m$	$c$	$k$	$k$ (Vendor)	$m$	$c$	$k$	$k$ (Vendor)
	<i>lbm</i>	<i>lb.s/in</i>	<i>lb/in</i>		<i>lbm</i>	<i>lb.s/in</i>	<i>lb/in</i>	
PED1 - XX	284.2	457.3	2.69E6	1.43E6	565.8	1351.0	4.67E6	3.20E6
PED1 - YY	66.1	0.2	1.69E6	1.43E6	102.9	635.4	3.18E6	3.20E6
PED2 - XX	253.2	391.6	2.36E6	1.43E6	367.5	1054.9	3.82E6	3.20E6
PED2 - YY	57.1	0.2	1.46E6	1.43E6	219.0	971.3	3.15E6	3.20E6

An example plot showing the amplitude of the measured FRFs is provided in *Figure 18*, where the frequency starts at 50 Hz because of the poor coherence below 50 Hz and also because the low frequency range is not a concern in general. There are two major peaks for the XX (horizontal) direction. The first peak (around 75 Hz) is demonstrated to be an axial mode by analyzing the mode shapes. Due to the imperfect hammer impact, the axial mode can be excited and reflected in the plot. This was verified by hitting different locations, and by reviewing the mode shapes of the corresponding frequencies.

The cross-coupling values are at least a magnitude smaller than the principal values for all pedestals, and therefore their contribution is not included in the tables. However, the cross-coupling was included in all identified models during analysis.

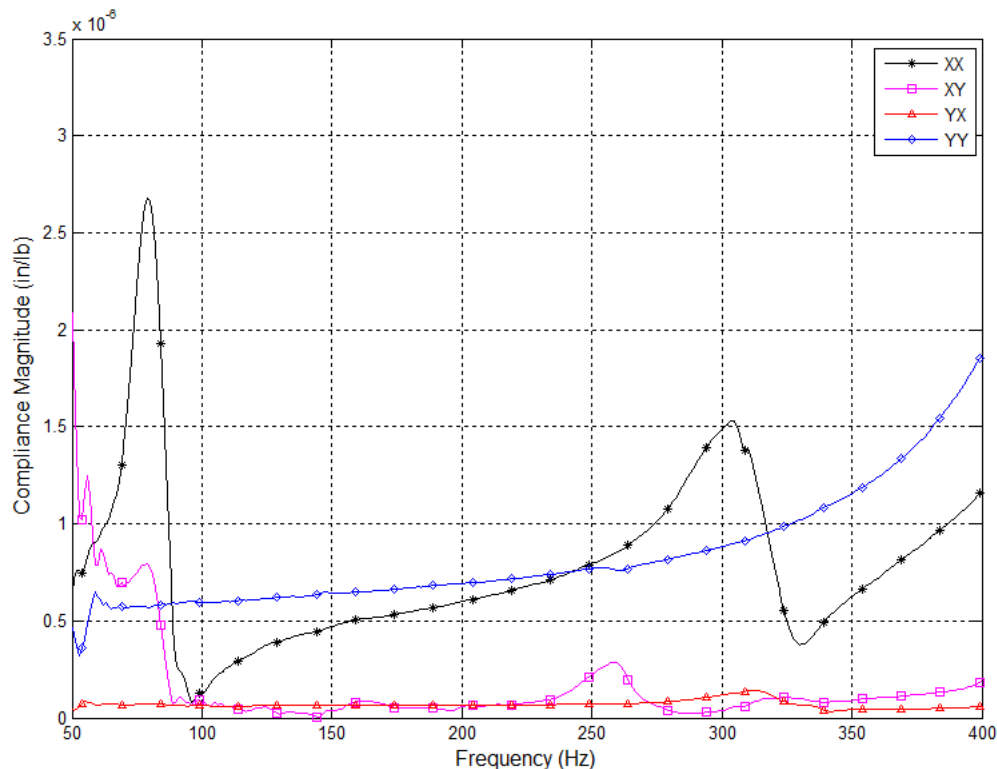

*Figure 18: Measured FRFs for Pedestal 1 – Stiffening Off*

An example plot showing the measured FRF and the model or curve-fitted data is provided in *Figure 19*, where the first 2 peaks were considered axial modes and then ignored in the curve-fitting. Note that for the Vendor provided data, the first peak is out of range of

the display. Different models will be compared later on.

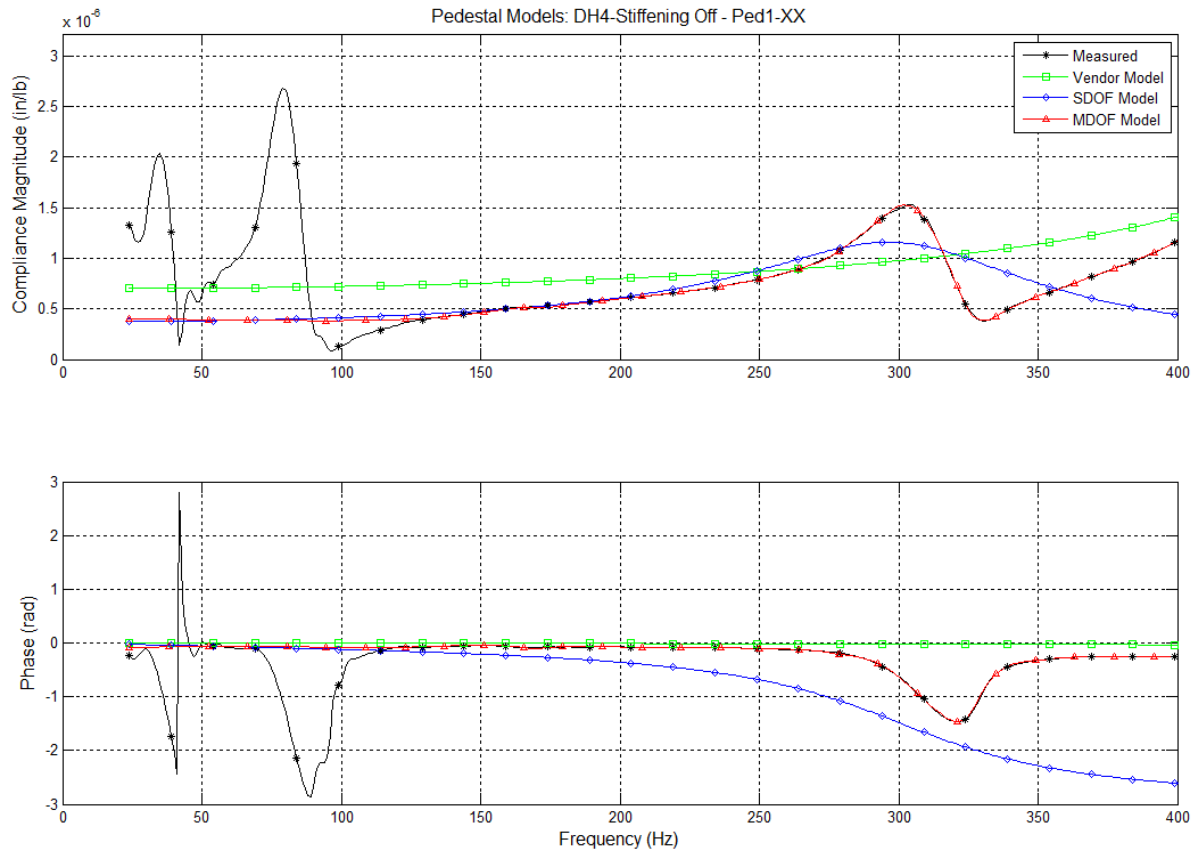

Figure 19: Measured vs Identified Models for DH4 - Pedestal 1 – Stiffening Off – XX

An example mode shape is provided in Figure 20.

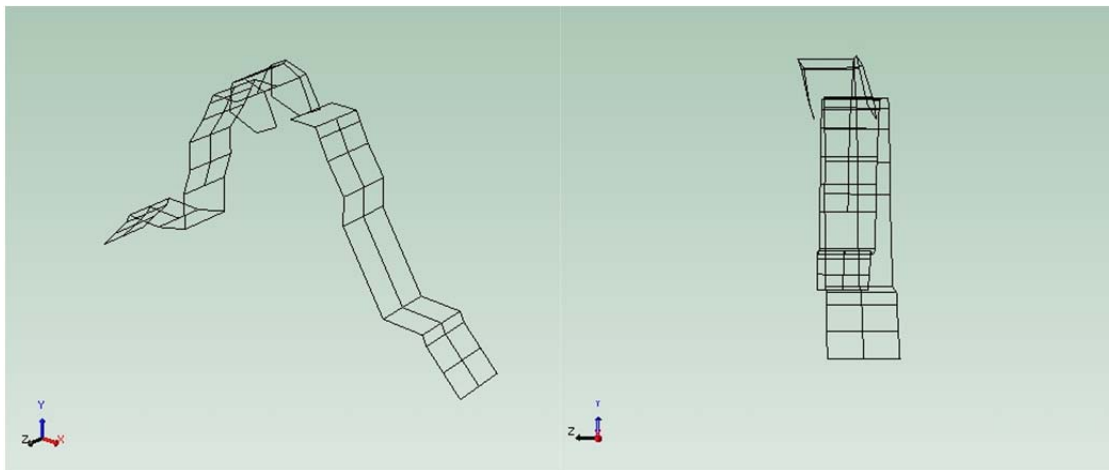

Figure 20: DH4 1st axial mode shape - 38 Hz

DH7 Pedestals

The modal parameters identified for each direction are provided in *Table 5*, where the stiffness provided by the Vendor and the stiffness from the added-mass (Plug) test are also listed.

*Table 5: SDOF model of DH7 pedestals (curve-fit)*

	Stiffening Off					Stiffening On				
	<i>m</i>	<i>c</i>	<i>k</i>	<i>k (Vendor)</i>	<i>k (Plug)</i>	<i>m</i>	<i>c</i>	<i>k</i>	<i>k (Vendor)</i>	<i>k (Plug)</i>
	<i>lbm</i>	<i>lb.s/in</i>	<i>lb/in</i>			<i>lbm</i>	<i>lb.s/in</i>	<i>lb/in</i>		
PED1 - XX	714.9	135.6	3.42E6	5.08E6	4.31E6	845.1	256.5	4.55E6	7.62E6	6.62E6
PED1 - YY	878.6	123.2	5.13E6	5.08E6	4.01E6	1094.4	328.9	7.88E6	7.62E6	7.28E6
PED2 - XX	647.1	110.5	3.16E6	5.08E6	5.03E6	751.0	198.9	4.21E6	7.62E6	1.02E7
PED2 - YY	886.3	105.8	5.16E6	5.08E6	4.11E6	1046.8	250.4	7.73E6	7.62E6	6.42E6

An example plot showing the amplitude of the measured FRFs is provided in *Figure 21*.

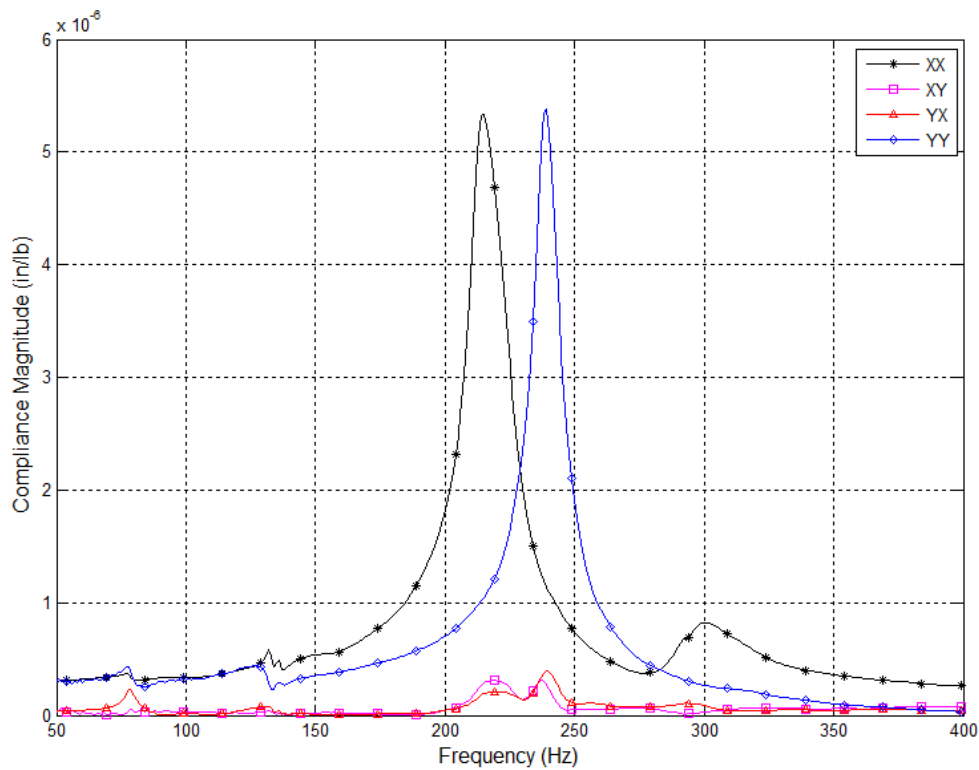

*Figure 21: Measured FRFs for DH7 - Pedestal 1 – Stiffening Off*

An example plot showing the measured FRF and the identified models is provided in *Figure 22*, where the model from the Vendor has a low damping value (10 lb.s/in), and therefore the peak is much higher and truncated.

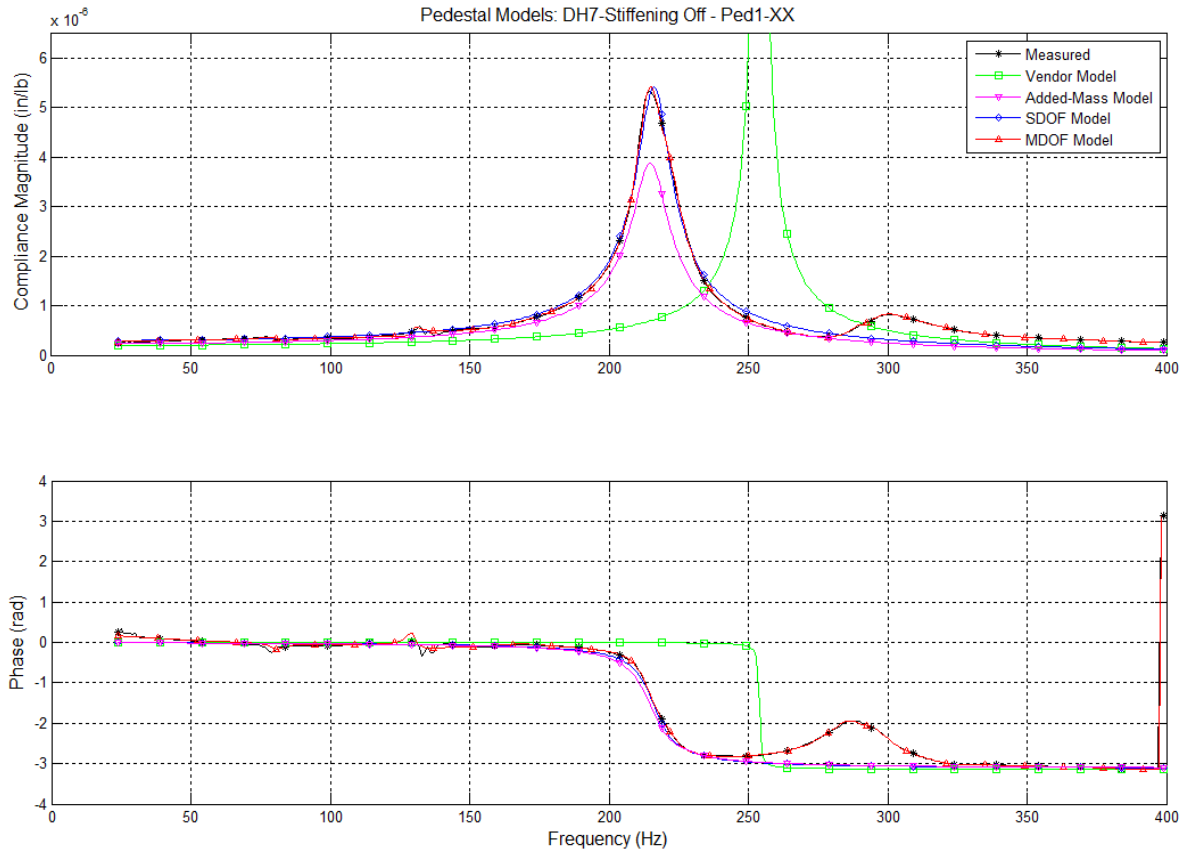

Figure 22: Measured vs Identified Models for DH7 - Pedestal 1 – Stiffening Off – XX

An example mode shape is shown in Figure 23.

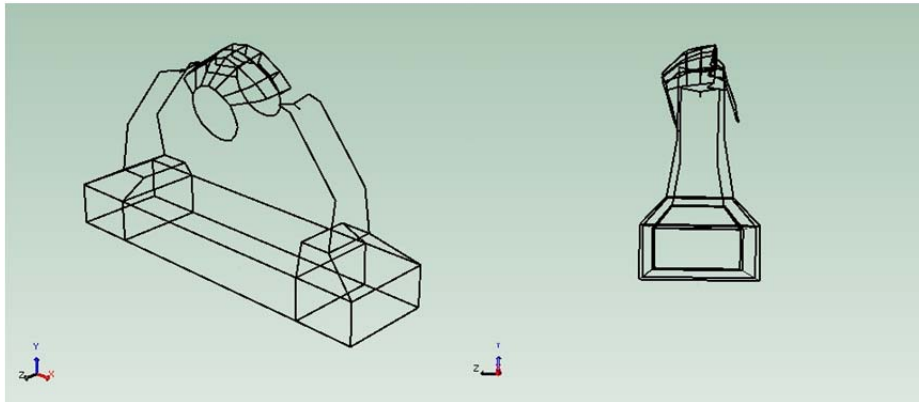

Figure 23: DH7 1st axial mode shape - 129 Hz

DH70 Pedestals

The modal parameters obtained for each method are provided in *Table 6*, where the Vendor provided stiffness is also listed.

*Table 6: SDOF model of DH70 pedestals (curve-fit)*

	Stiffening off				Stiffening On			
	<i>M</i>	<i>c</i>	<i>k</i>	<i>k (Vendor)</i>	<i>m</i>	<i>c</i>	<i>k</i>	<i>k (Vendor)</i>
	<i>Lbm</i>	<i>lb.s/in</i>	<i>lb/in</i>		<i>lbm</i>	<i>lb.s/in</i>	<i>lb/in</i>	
PED1 - XX	1952.0	201.0	5.50E6	6.67E6	1944.3	145.5	7.33E6	1.30E7
PED1 - YY	1774.3	175.2	7.55E6	6.67E6	1916.9	805.0	1.01E7	1.30E7
PED2 - XX	1746.3	205.0	5.10E6	6.67E6	2100.4	225.0	8.00E6	1.30E7
PED2 - YY	1751.5	145.5	7.60E6	6.67E6	1870.2	1200.0	9.51E6	1.30E7

An example plot showing the compliance magnitude of the measured FRFs is provided in *Figure 24*. Note that there are 3 peaks in the XX direction, and multiple tests have been performed to confirm the measurement. The cause for multiple peaks in the XX direction is unknown. The authors were unsuccessful in acquiring further explanation or raw FRFs from the Vendor.

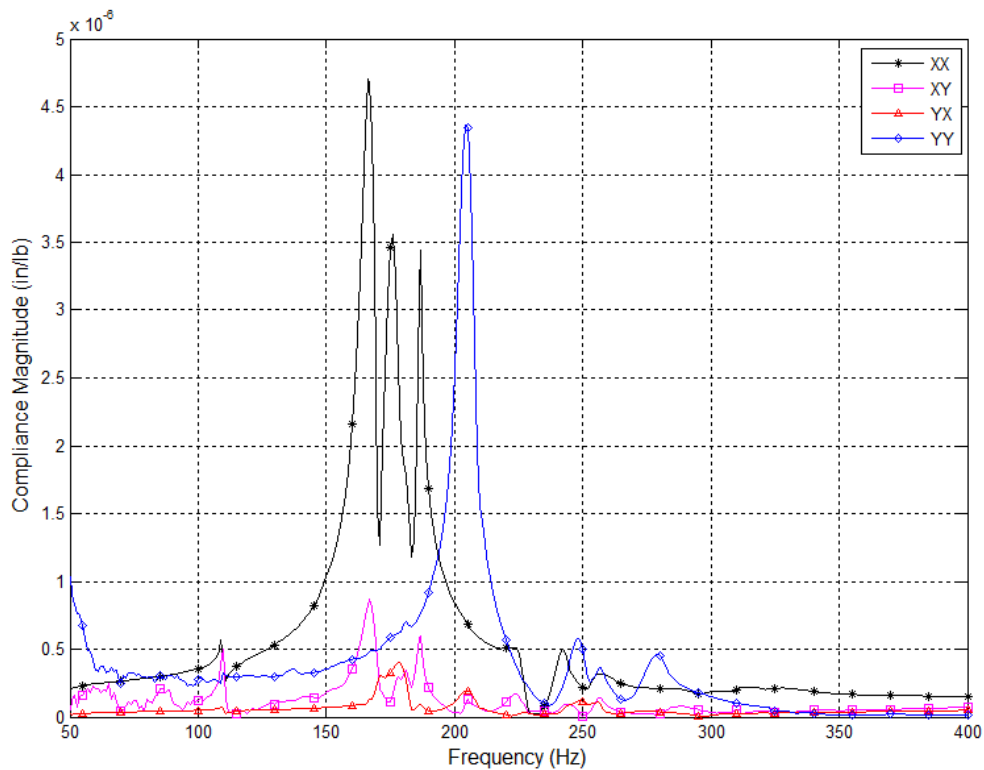

*Figure 24: Measured FRFs for DH70 - Pedestal 1 – Stiffening Off*

An example plot showing the measured FRF and the model or curve-fitted data is provided in *Figure 25*, where the FRF generated from the Vendor provided data has a low damping value (10 lb.s/in), and therefore the peak is much higher and truncated.

Due to time constraints of the Balancing Facility schedule, detailed mode shapes of the DH70 pedestals could not be collected. However, simplified mode shapes of a single row of points along the bearing cap were measured for a glimpse into the pedestal behavior, as shown in *Figure 26* for example, where arrows were used to help identifying the deformation directions within a single standing wave pattern.

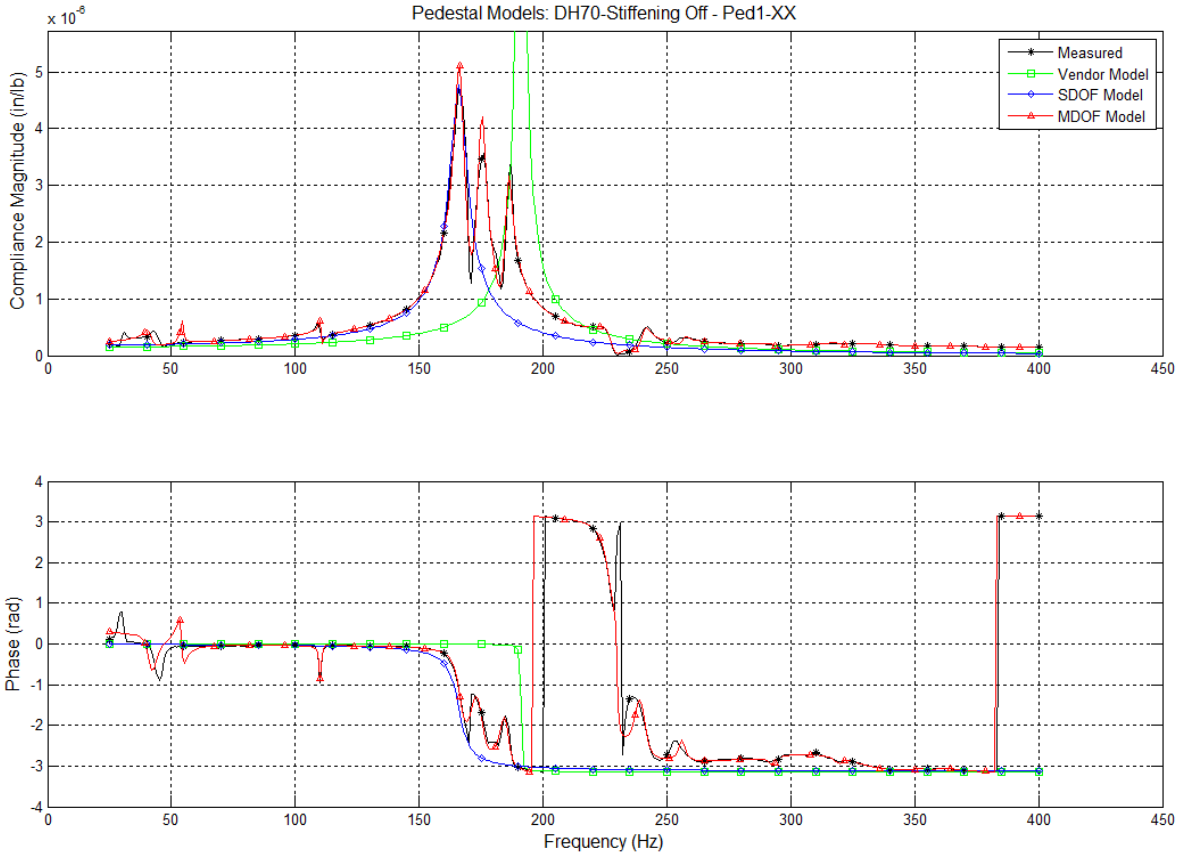

Figure 25: Measured vs Identified Models for DH70 - Pedestal 1 – Stiffening Off - XX

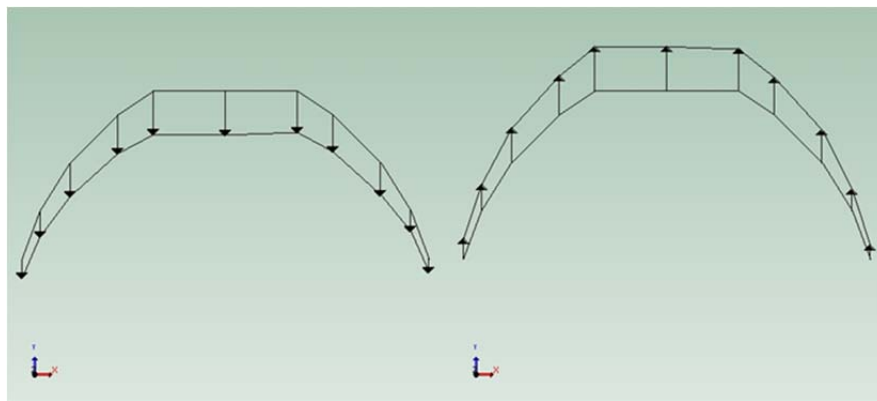

Figure 26: DH70 1st vertical mode shape - 204 Hz

### Discussion

From the measured FRFs, the following observations can be made:

1. The dynamics of different pedestals are largely different, e.g., DH7 has one clean peak within the concerned range while DH70 has multiple peaks.
2. The dynamics of the horizontal and vertical directions are different both in terms of peak locations and magnitude.



3. The cross-coupling dynamics is at least a magnitude smaller than the principal dynamics in this instance.

For the models, the following observations can be made:

1. The SDOF model, the Vendor model, and the Plug model are relatively close to each other.
2. Usually the Y (vertical) direction, different models have closer values (2-27% from the Vendor model stiffness). The discrepancies in the X (horizontal) direction are usually larger (14-88% from the Vendor model stiffness).

## UNBALANCE VERIFICATION

With all the effort trying to obtain more accurate transfer functions as presented in the previous section, this section will show the results of implementing different types of pedestal models in the rotordynamics analyses of a shop order.

This shop order was balanced in the Balancing Facility and unbalance verification was performed with residual unbalance subtraction. For this method, one can see Nicholas (1997) for details. Later, the rotor was assembled into the compressor and passed the tests on the test floor. The unit was shipped to the field and successfully running.

The rotor, as shown in the figure below, is about 3640 pounds with 6 x 3 inch bearings. In Balancing Facility, shop bearings were used with oil lift grooves at the two bottom pads. The unbalance verification tests were done with DH7 pedestals (stiffening on).

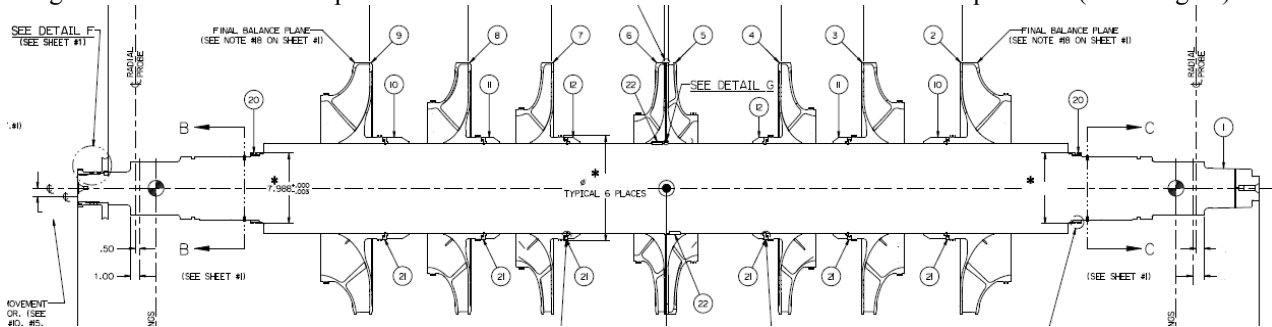

Figure 27: Rotor Cross-sectional Drawing

Standard bearing models were applied (measured bearing clearances and oil inlet temperature are used, but the oil lift grooves are not considered). The system was analyzed using different pedestal models. The mass of the bearing and bearing adapter is included in the analysis. The results are plotted in Figure 28, which shows:

1. There are no significant differences between different pedestal models.
2. All models predict higher first critical speed than the measured value (~200-300 rpm higher, 7-20% above the measured first critical speed), and lower than the rigid support (~100 rpm lower).

Although there is some improvement matching the measured response compared to the rigid support model, the improvement is not as much as expected. One of the first things needs to be checked is the rotor/bearing model, which was verified by the mechanical run data from the test floor. Figure 29 shows the comparison between the prediction and the measurement from the test floor. Note that

1. The rotor is slightly different from the one used in the Balancing Facility, such as the dry gas seals and coupling.
2. The bearings are slightly different as well: the job bearings do not have the oil lift.
3. No support dynamics is used (infinite stiffness behind the bearings).
4. There is no unbalance verification done on the test floor, so the measured 1X uncompensated data shown in the figure is with the unknown residual unbalance. The same unbalance used in the analysis above is used for the test floor analysis.

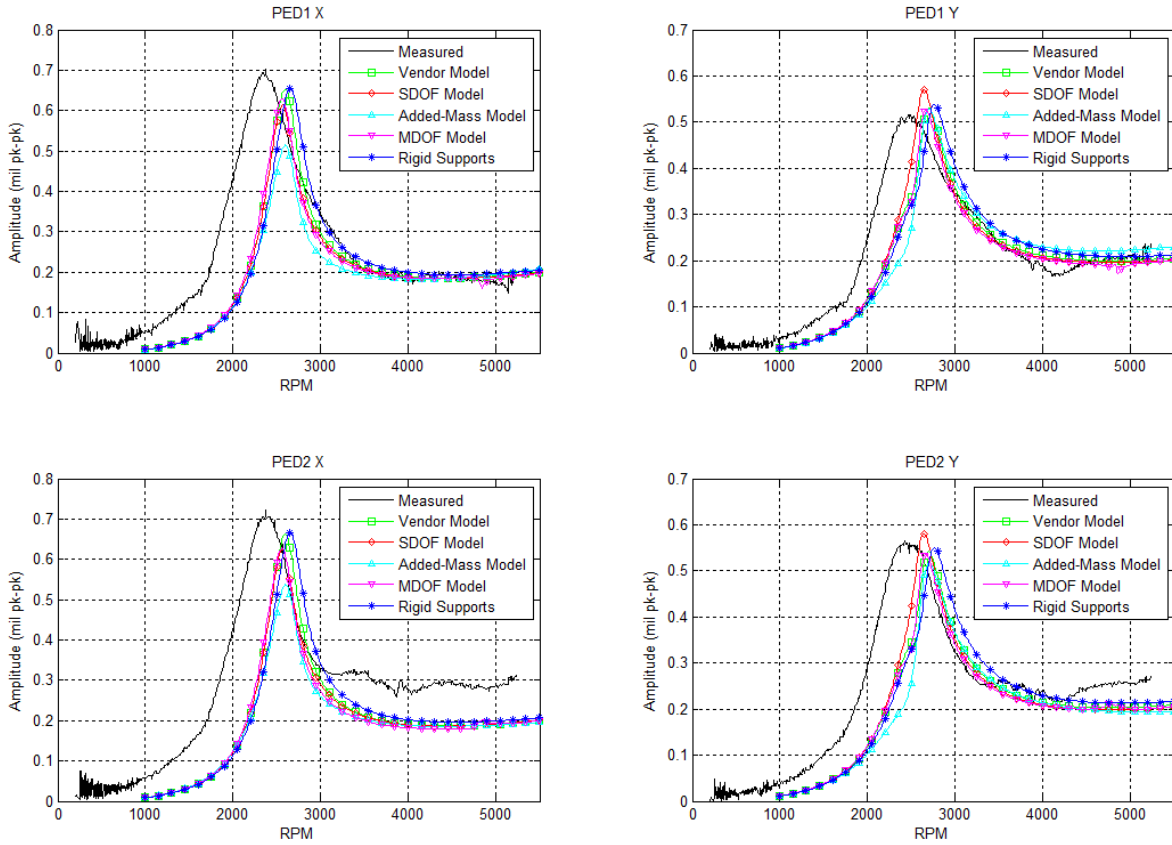

Figure 28: Unbalance Response Measurement vs. Prediction from Different Pedestal Models

The first peak matches the measurement within 5%.

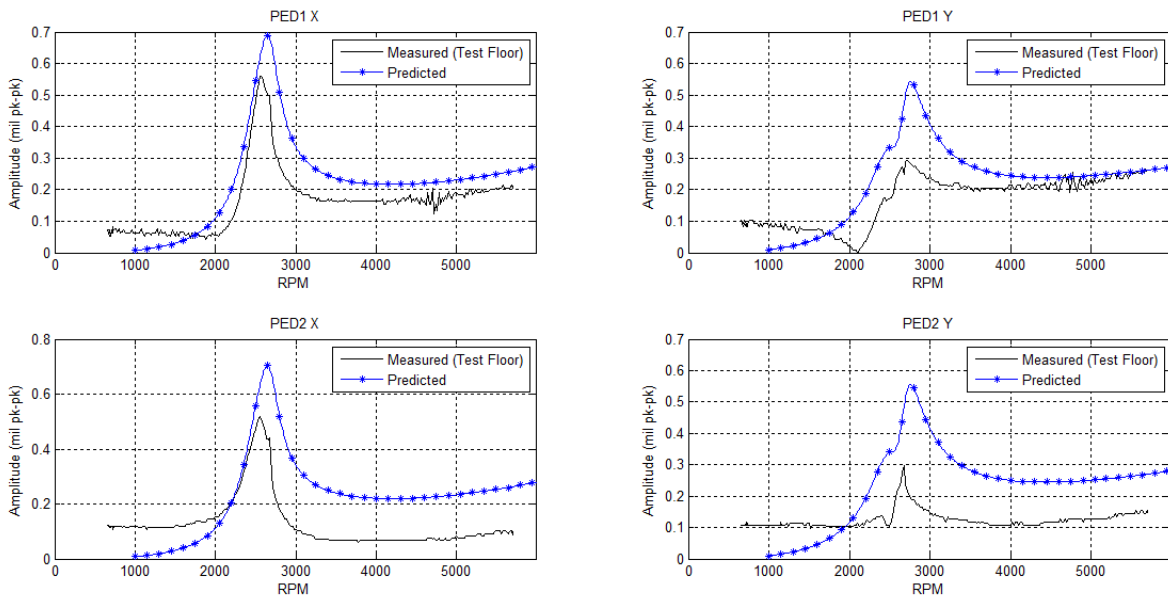

Figure 29: Test Floor Measurement vs. Prediction

Besides the pedestal dynamics, another factor, the oil lift, may have some unknown effects. For this particular study, the bearing dynamics (stiffness and damping) is adjusted to match the first peak (50% of the original values for all speeds is used for this particular case), and the result is shown in *Figure 30*, where the rigid support remains unchanged as a comparison. Note that even though the first peak matches better, the amplitude at higher speed deviates more. Therefore, the actual pedestal dynamics must be different in a more complex manner.

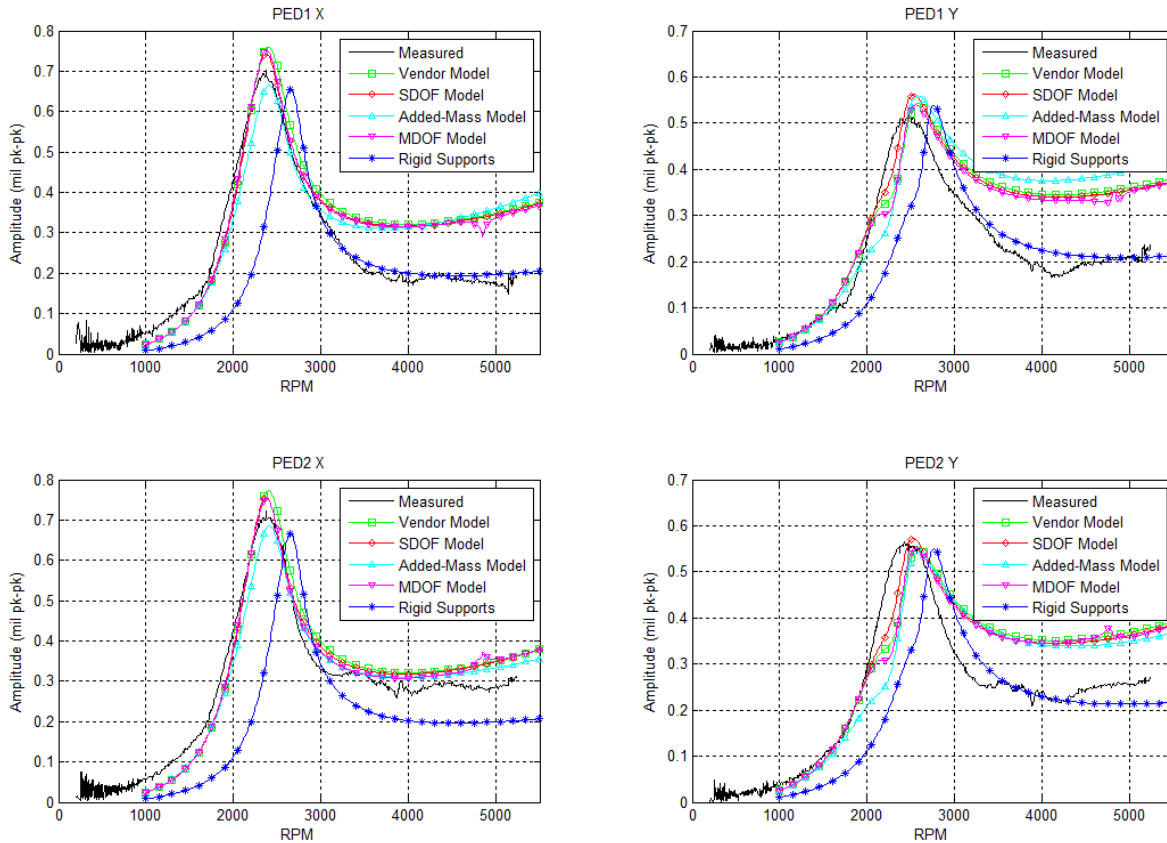

Figure 30: Measurement vs. Prediction with Bearing Adjustment  
Table 7. Bearing Stiffness (Thrust End, Average Clearance)

Bearing Coefficients (lb/in)					
rpm	Kxx	Kyy	$\omega C_{xx}$	$\omega C_{yy}$	Somm.
1000	2.12E+06	1.13E+06	1.17E+06	6.62E+05	0.0067
2000	1.62E+06	8.97E+05	1.10E+06	7.17E+05	0.0741
3000	1.42E+06	8.24E+05	1.18E+06	8.03E+05	0.1415
3450	1.37E+06	8.14E+05	1.23E+06	8.48E+05	0.1752
4000	1.33E+06	8.11E+05	1.28E+06	9.06E+05	0.2157
5000	1.29E+06	8.24E+05	1.36E+06	1.02E+06	0.2763
5174	1.29E+06	8.28E+05	1.38E+06	1.04E+06	0.2898
6000	1.28E+06	8.53E+05	1.45E+06	1.13E+06	0.3487
7000	1.28E+06	8.93E+05	1.55E+06	1.25E+06	0.4111
8000	1.30E+06	9.42E+05	1.65E+06	1.38E+06	0.4785
9000	1.33E+06	9.96E+05	1.76E+06	1.50E+06	0.5459
10000	1.37E+06	1.05E+06	1.88E+06	1.64E+06	0.6133

Despite some rather large differences (e.g. mass and stiffness) between the pedestal models, all pedestal models yield quite similar rotordynamic results for this study in terms of both the critical speed and amplitude. The reason for this situation can be explained by the bearing coefficients shown in *Table 7*. The provided bearing coefficients are the nominal values before the adjustment.

In the concerned range, i.e. 2000-6000 rpm, the bearing stiffness is about  $1.2 \times 10^6 - 1.6 \times 10^6$  lb/in, while the stiffness of the pedestals from all models are above  $4.2 \times 10^6$  lb/in (near 3.5x the bearing stiffness specified by API 617) for DH7 stiff in both X and Y directions. Therefore the effect of the difference between models is not manifested in the particular case. For other cases where the bearing stiffness is higher relative to pedestal stiffness, large differences will show up.

Besides the shop order used above, the authors also compared the predictions of some other shop orders and almost all of them showed a higher predicted first critical speed, including the ones without oil lift grooves. It appears that the measured FRFs (or any method mentioned in this paper) are not matching the entire support dynamics (excluding bearings). An example for DH4 (no oil lift) is shown in *Figure 31* and *Figure 32*.

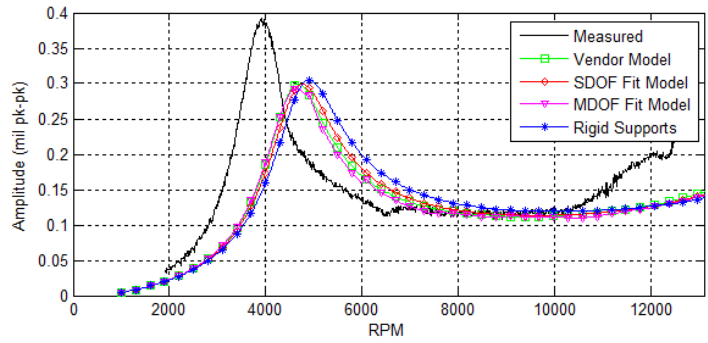

Figure 31: Measurement vs. Prediction for DH4

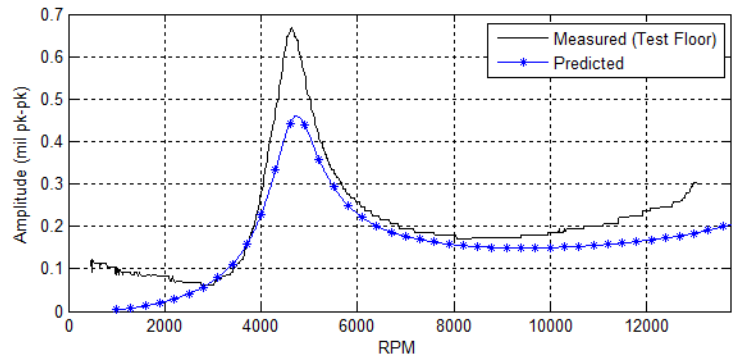

Figure 32: Test Floor Measurement vs. Prediction

Some possible reasons for the discrepancies between the models and support dynamics are listed below:

1. Non-linearity of the support, i.e., all measurements are obtained with rather small forces (~2-50 lbf), while the dynamics may change when shaking with a rotor (~1000-10000 lbf). The components that could have this non-linearity are:
  - a. Bearing cap. This is unlike the reason once the bolts are properly tightened. The test floor data seem to indicate that bearing cap is not a problem.
  - b. Pedestal. The 3 peaks in *Figure 24* indicate the complexity of the pedestal, so it is quite possible to have some non-linear dynamics.
  - c. Foundation/rail. The difference between the foundation of the balancing facility and that of the test floor might not be significant in terms of e.g. stiffness, but since there is always a relatively large casing for the rotor on the test floor, the foundation influence might be less for the test floor than for the balancing facility.
2. Incorrect bearing dynamics due to
  - a. The Balancing Facility usually runs the rotor with vacuum, which might have some effects on the bearings dynamics.

- b. Hydrostatic lift grooves, when used, will alter the dynamic characteristics of the bearings. This may not have much effect, though, because for DH4 (no lift grooves) similar behavior is observed as shown in *Figure 31* and *Figure 32*.

## CONCLUSIONS AND RECOMMENDATIONS

This paper studied the dynamics of the Balancing Facility pedestals.

The API standards related to balancing acceptance criteria were discussed, and relation to the pedestal stiffness was illustrated with data of 723 shop orders.

Extensive modal testing was conducted to all pedestals of the balancing facility in the authors' company. The measured FRFs are curve-fitted, and the parameterized models are compared to those from the Vendor, and those from added-mass (Plug) test. All models were used in the unbalance verification, and the predicted results were presented.

From modal tests and unbalance verification, the following points can be made:

1. All bolts, including bedbolts and bearing cap bolts, should be tightened to proper values to avoid potential problems.
2. All models (the SDOF from measured FRFs, the Vendor model, and the Plug model) yield relatively similar results, which means each of them can be considered a valid method.
3. All models, when used in the analysis, yield similar results in the unbalance verification for the given case, likely due to the relatively large stiffness of the pedestals (near 3.5 times that of the bearings). Therefore, the authors cannot conclude any one model to be best for the cases examined, even though the MDOF model should be more accurate. Note that the Vendor intentionally tunes the pedestal to move the resonance beyond the operating range. Therefore, as long as the bearing stiffness is below roughly 1/3 of the pedestal stiffness, all models are practically equivalent.
4. None of the models closed the gap between the prediction and the measurement, which disproves the author's original thoughts and opens the door for further investigations.

## NOMENCLATURE

Consultant	= Outside consulting firm used to measure pedestal dynamics
FRF	= Frequency response function
MCS	= Maximum continuous speed
MDOF	= Multiple degree of freedom
SDOF	= Single degree of freedom
Vendor	= Original pedestal manufacturer

## APPENDIX A: ADDED-MASS METHOD

This method is straight forward based on a single-mass system. As shown in Equations (4), the natural frequency of the system can be calculated based on stiffness and mass.

$$\omega_0 = \sqrt{\frac{kg}{m_0}} \quad (4)$$

When a known mass is added to the original mass, the calculation becomes:

$$\omega_1 = \sqrt{\frac{kg}{m_0 + m_1}} \quad (5)$$

where

$\omega$  is natural frequency in rad/s

$k$  is the stiffness in lb/in

$m$  is the mass in lbm

$g$  is the gravity constant = 386.09 in/s<sup>2</sup>

Solving these two equations yields the stiffness and mass:

$$k = \frac{m_1}{g} \frac{\omega_0^2 \omega_1^2}{\omega_0^2 - \omega_1^2} \quad (6)$$

and

$$m_0 = m_1 \frac{\omega_1^2}{\omega_0^2 - \omega_1^2} \quad (7)$$

The damping can be calculated based on the amplification factor measured from the FRF (see e.g. Ewins, 1984 for details).

$$c = \frac{\sqrt{mk/g}}{AF} \quad (8)$$

where

$c$  is damping in lb.s/in

$AF$  is amplification factor

$m$ ,  $k$  and  $g$  are the same as above

## APPENDIX B: PEDESTAL TRANSFER FUNCTIONS

The response to a given force input at the pedestals is defined as:

$$\begin{Bmatrix} x \\ y \end{Bmatrix} = \begin{bmatrix} dc_{xx} & dc_{xy} \\ dc_{yx} & dc_{yy} \end{bmatrix} \begin{Bmatrix} f_x \\ f_y \end{Bmatrix} \quad (9)$$

where

$x$ ,  $y$  are the responses in the  $x$  and  $y$  directions, respectively.

$dc_{ij}$  is the dynamic compliance measured in the  $i$  direction to a force in the  $j$  direction

$f_x$ ,  $f_y$  are the force inputs in the  $x$  and  $y$  directions, respectively.

The dynamic compliance is measured directly by modal tests. Each term in the dynamic compliance matrix refers to a single frequency response function (FRF). The FRFs are used to calculate polynomial transfer functions.

The transfer function matrix,  $G(s)$ , for a pedestal is introduced:

$$\begin{Bmatrix} X \\ Y \end{Bmatrix} = \begin{bmatrix} g_{xx} & g_{xy} \\ g_{yx} & g_{yy} \end{bmatrix} \begin{Bmatrix} f_x \\ f_y \end{Bmatrix} \quad (10)$$

The components of the transfer function matrix are a function of the complex frequencies. The transfer function matrix was obtained in multiple ways described below.

For a SDOF system, the dynamic compliance for an FRF is defined as:

$$g_{ij}(s) = \frac{1}{-\omega^2 m_{ij} + c_{ij}s + k_{ij}} \quad (11)$$

where

$g_{ij}$  is the transfer function matrix element corresponding to  $dc_{ij}$ .

$\omega$  is the frequency ( $\frac{\text{rad}}{\text{s}}$ ).

$m$  is the modal mass.

$c$  is the damping.

$k$  is the static stiffness.

For a MDOF system, the transfer function matrix elements are defined as a function of rational fraction polynomials:

$$g_{ij}(s) = \frac{a_n s^n + a_{n-1} s^{n-1} + \dots + a_1 s + a_0}{b_m s^m + b_{m-1} s^{m-1} + \dots + b_1 s + b_0} \quad m > n \quad (12)$$

Where

- n is the order of the numerator polynomial.
- a<sub>n</sub> through a<sub>0</sub> are the numerator polynomial coefficients.
- m is the order of the denominator polynomial.
- b<sub>m</sub> through b<sub>0</sub> are the denominator polynomial coefficients.

Each measurement direction for each pedestal was curve fit using the rational fractional polynomial method (Richardson, 1982) to compute the MDOF transfer function matrices. In this method, s is the normalized complex frequency to an arbitrary frequency limit. In all curve-fits performed in this report, s is normalized against a frequency limit of 400 Hz.

The dynamic stiffness for a pedestal is then defined as the inverse of the transfer function matrix as:

$$[K(s)] = [G(s)]^{-1} \quad (13)$$

An example of the calculated MDOF transfer function for the DH7 pedestal 2, stiffening off, horizontal (XX) FRF is provided below.

*Table 8. MDOF Transfer Function Polynomial Coefficients Example*

Numerator Coefficients (A)		Denominator Coefficients (B)	
a <sub>19</sub>	-6.6401E03	b <sub>20</sub>	5.8805E10
a <sub>18</sub>	2.8124E03	b <sub>19</sub>	6.7265E10
a <sub>17</sub>	-2.1288E04	b <sub>18</sub>	3.0677E11
a <sub>16</sub>	1.7360E04	b <sub>17</sub>	2.8928E11
a <sub>15</sub>	-2.2822E04	b <sub>16</sub>	6.6629E11
a <sub>14</sub>	3.9785E04	b <sub>15</sub>	5.2264E11
a <sub>13</sub>	-4.2080E03	b <sub>14</sub>	7.8684E11
a <sub>12</sub>	4.5754E04	b <sub>13</sub>	5.1593E11
a <sub>11</sub>	1.0167E04	b <sub>12</sub>	5.5245E11
a <sub>10</sub>	2.9003E04	b <sub>11</sub>	3.0318E11
a <sub>9</sub>	8.8102E03	b <sub>10</sub>	2.3656E11
a <sub>8</sub>	1.0243E04	b <sub>9</sub>	1.0834E11
a <sub>7</sub>	3.0771E03	b <sub>8</sub>	6.0868E10
a <sub>6</sub>	1.9129E03	b <sub>7</sub>	2.3049E10
a <sub>5</sub>	5.0455E02	b <sub>6</sub>	8.8918E09
a <sub>4</sub>	1.6537E02	b <sub>5</sub>	2.7216E09
a <sub>3</sub>	3.4656E01	b <sub>4</sub>	6.4963E08
a <sub>2</sub>	4.9161E00	b <sub>3</sub>	1.5212E08
a <sub>1</sub>	6.8013E-01	b <sub>2</sub>	1.7515E07
a <sub>0</sub>	2.7103E-03	b <sub>1</sub>	2.7012E06
		b <sub>0</sub>	1.0067E04



## REFERENCES

- API 611, 2008, Reaffirmed 2014, “General-Purpose Steam Turbines for Petroleum, Chemical, and Gas Industry Services”, Fifth Edition, American Petroleum Institute, Washington, D.C.
- API 612, 2005, “Petroleum, Petrochemical and Natural Gas Industry – Steam Turbines – Special-purpose Applications”, Sixth Edition, American Petroleum Institute, Washington, D.C.
- API 612, 2014, “Petroleum, Petrochemical and Natural Gas Industry – Steam Turbines – Special-purpose Applications”, Seventh Edition, American Petroleum Institute, Washington, D.C.
- API 616, 2011, “Gas Turbines for the Petroleum, Chemical and Gas Industry Services”, Fifth Edition, American Petroleum Institute, Washington, D.C.
- API 617, 2002, “Axial and Centrifugal Compressors and Expander-compressors for Petroleum, Chemical, and Gas Service Industries”, Seventh Edition, American Petroleum Institute, Washington, D.C.
- API 617, 2014, “Axial and Centrifugal Compressors and Expander-compressors”, Eighth Edition, American Petroleum Institute, Washington, D.C.
- API 684, 2005, Reaffirmed 2010, “API Standard Paragraphs Rotordynamic Tutorial: Lateral Critical Speeds, Unbalance Response, Stability, Train Torsionals and Rotor Balancing”, Second Edition, American Petroleum Institute, Washington, D.C.
- API 687, 2001, Reaffirmed 2009, “Rotor Repair”, First Edition, American Petroleum Institute, Washington, D.C.
- Ewins, 1984, D.J. *Modal Testing: Theory Practice and Application*, Second edition, Research Studies Pr Ltd
- ISO 1940-1, 2003, “Mechanical vibration – Balance quality requirements for rotors in a constant (rigid) state – Part 1: Specification and verification of balance tolerances”, Second edition, Switzerland
- ISO 5343, 1983, “Criteria for evaluating flexible rotor balance”, First edition, Switzerland
- ISO 11342, 1998, “Mechanical vibration – Methods and criteria for the mechanical balancing of flexible rotors”, Second edition, Switzerland
- Jackson, C., 1979, *The Practical Vibration Primer*, Gulf Publishing Co., Houston TX.
- Nicholas, J. C., Whalen, J. K., and Franklin, S. D., 1986, “Improving Critical Speed Calculations Using Flexible Bearing Support FRF Compliance Data,” Proceedings of the Fifteenth Turbomachinery Symposium, Turbomachinery Laboratory, Texas A&M University, College Station, Texas, pp. 69-78.
- Nicholas, J. C., Stephen, L. E., Kocur, J.A. and Hustak, J. F., 1997, “Subtracting Residual Unbalance for Improved Test Stand Vibration Correlation,” Proceedings of the Twenty Sixth Turbomachinery Symposium, Turbomachinery Laboratory, Texas A&M University, College Station, Texas, pp. 7-18.
- Richardson, M. H. and Formenti, D. L., 1982, “Parameter Estimation from Frequency Response Measurements Using Rational Fraction Polynomials”, 1st IMAC Conference, Orlando FL, pp 4-10.
- Stephenson, RW and Rouch, KE, 1992, *Generating Matrices of the Foundation Structure of a Rotor System from Test Data*, Journal of Sound and Vibration, Volume 154, Issue 3, Pages 467-484
- Vazquez, J. A., Barrett, L.E. and Flack, R.D., 2001, “Including the Effects of Flexible Bearing Supports in Rotating Machinery”, International Journal of Rotating Machinery, Vol. 7, No. 4, pp. 223-236.
- Zhou, S., Sun, Z. and Li, H., 2013, “Dynamic Stiffness Analysis and Modal Identification on Bearing Support of Large-Scale High-Speed Dynamic Balancing Machine”, Advances in Vibration Engineering, Vol. 12, No. 6, pp. 587-609.

## **ACKNOWLEDGEMENTS**

The authors would like to thank Elliott Group for permission to publish this paper. In addition, we wish to thank BRG Machinery Consulting for the initial modal testing work reported within this paper.