

MAINTENANCE AND TROUBLESHOOTING OF SINGLE-STAGE PUMPS

by

W. Ed Nelson

Manager of Maintenance Services

Texas City Refinery, Amoco Oil Company

Texas City, Texas



W. Ed Nelson is the Manager of Maintenance Services for Amoco Oil Company in Texas City, Texas. His responsibilities include refinery instrument, electrical and machinery repair, as well as mobile equipment operation and maintenance training.

Mr. Nelson received a B.S. in Mechanical Engineering degree from Texas A&M University in 1951. He has spent twenty-eight years in various engineering, materials management, and maintenance positions in Amoco's Texas City refinery. He is a member of ASME and the International Maintenance Institute, and he is an advisory committee member for the Pump Symposium. He is a registered professional engineer in the State of Texas.

Mr. Nelson has authored several technical articles and is a noted speaker at seminars and technical meetings. He is listed in several editions of Who's Who in the South and Southwest and World's Who's Who in Commerce and Industry.

Mr. Nelson has authored several technical articles and is a noted speaker at seminars and technical meetings. He is listed in several editions of Who's Who in the South and Southwest and World's Who's Who in Commerce and Industry.

ABSTRACT

A centrifugal pump's hydraulic performance and reliability can differ drastically from its published performance expectations. The cause of the discrepancy may involve the hydraulic features of the pump. NPSH (net positive suction head) has received a lot of attention in most handbooks, but the trade-offs of NPSH against recirculation, piping design, system operation and mechanical features of the pump itself are not discussed in most instances.

Some of the areas that have proven troublesome in pump operation are as follows:

1. Axial and radial hydraulic forces caused by recirculation effects.
2. Hydraulic forces (axial and radial) hydraulic forces caused by recirculation effects.
3. Bearing system design as related to hydraulic loads.
4. Hot oil pumps that suffer from thermal distortion and other installation problems.
5. Piping designs that cause vortexing and other disturbances.

These subjects are discussed from the standpoint of maintenance experience at a large Gulf Coast refinery.

INTRODUCTION

Increased reliability and reduced maintenance costs of pumps are required for improved plant profitability in the hydrocarbon processing industry. Centrifugal pump design is more of an art than a science, and many engineers regard such pumps as rather mysterious devices to move fluids. In addition,

refineries today require higher flows and higher heads than before, because of increased size of the processing units. Services that once called for rather simple single-stage, single-suction, overhung process pumps now require large double-suction between bearings designs, operating at lower speeds, due to net positive suction head requirements. This trend has introduced difficulties into the art of pump design and construction that have not been fully understood by either the manufacturer or the user.

The American Petroleum Institute Standard 610, "Centrifugal Pumps for General Refinery Service," was developed a number of years ago to provide a reliable guide to use when specifying a pump for use in process service. The specification combines the experiences of many individuals in the operation, installation, and manufacture of pumps. It has received wide acceptance throughout the hydrocarbon processing industry. Despite frequent revisions (the sixth in 1981) to this API standard, pump problems continue to plague our industry.

More intelligent application of the horizontal single-stage process pump, the mainstay of the industry, is of paramount importance. Some of the areas of the more frequently encountered problems with pumps selected using API 610 as a guideline will be presented in this paper.

HYDRAULIC PERFORMANCE

A pump's hydraulic performance and reliability can differ drastically from its published performance expectations. The cause of the discrepancy may involve the hydraulic features of the pump. At times, the cause of the malfunction may be faulty dimensions of internal parts. These are difficult to identify. The pump must be dismantled for a careful dimensional analysis of each major component. The hydraulics and the mechanical considerations of a pump are directly related. The two cannot be separated without disastrous results.

Traditional pump handbooks fail to tie the whole pump together. Most pump handbooks consist of many pages of technical data—pressure drops, conversion tables, etc.; but they do little to explain the practical considerations of pumps. Three brief paragraphs, not found in most handbooks, can relate hydraulic conditions to possible pump mechanical problems:

1. Centrifugal pumps should be operated as much of the time as possible at or near the manufacturer's design rated conditions. This is usually the point of best efficiency (BEP). Impeller vane angles and the size of pump liquid channels can be correctly designed for only one point of operation. For any other points of operation, these angles and liquid channels are either too large or too small.

2. Excess capacity—any pump operated at excess capacity, beyond BEP and lower head, will surge and vibrate, causing bearings and shaft troubles and require excess power.

3. Reduced capacity—when operating at reduced capacity, less than BEP and higher head, the incorrect vane angles

cause eddy flows in the impeller and casing and will result in erosion of the impeller, casing and wearing rings. The radial load on the rotor increases, causing higher shaft stresses, increased shaft deflection, bearing troubles and accelerated deterioration of wearing rings.

NPSH and Cavitation

NPSH (net positive suction head) is a major factor in successful pump operation, yet it is a widely misunderstood term. Every pump handbook is loaded with NPSH calculations that treat the suction conditions as a static situation when they are more of a dynamic, flowing condition.

Cavitation is another subject that is handicapped by overly simplistic definitions. Most handbooks discuss vapor pressure and a collapsing bubble theory. In reality, much "cavitation" is mechanically induced by non-uniform flow upstream of the impeller vanes, manufacturing inaccuracies in the case (casting core slippage; etc.) or piping configurations. An old definition of pump cavitation says that when the difference between the design head and capacity, with flooded water suction, and the actual head developed is over 3 percent, the pump is cavitating. It is this cavitation point that is normally plotted on the pump performance curve as the NPSH required. This definition gets us in trouble, since many engineers assume that this guideline assures that no cavitation should take place. A better definition of NPSH required must be developed and more accurate curves of NPSH required versus capacities are needed.

For many years a "hydrocarbon correction factor" was applied that gave this NPSH required a wide safety margin. Recent experiences have shown that these correction factors are not accurate for all mixtures of hydrocarbons, at all temperatures and pressures.

Recirculation—A Neglected Matter

The term "recirculation" is not in most pump handbooks. It is a term developed by several pump experts to cover the "eddy flows" of the simplified three-paragraph pump handbook. It consists of "eddy flows" in three areas (Figure 1):

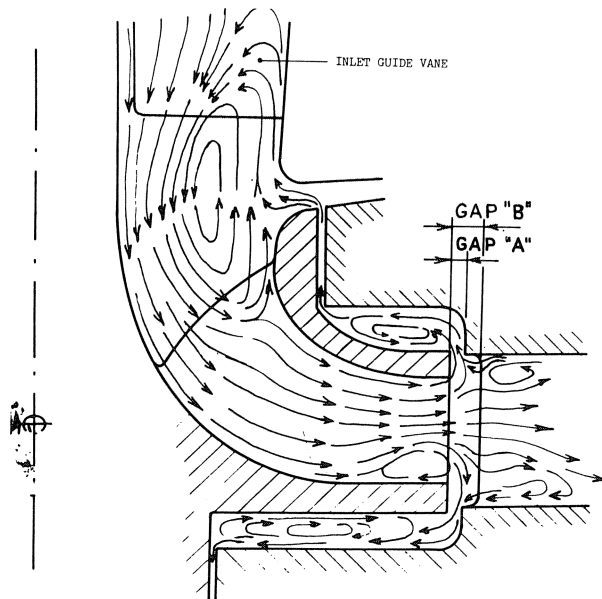

Figure 1. Secondary Flow Pattern In and Around a Pump Impeller Stage at Off-Design Flow Operation [4].

1. Flow "recirculation" at the impeller eye—generally of off-design flows—damage is always at the impeller eye or inlet areas of the casing. This is the eddy flow referred to under reduced flow of the third paragraph of original of the simple handbook.

2. Flow "recirculation" at the impeller vane tips—damage is at the impeller O.D. This eddy flow is caused by reduced capacity flows and improper impeller tip clearance or alignment.

3. Flow "recirculation" around impeller shrouds—damage is seldom seen on the impeller; it is seen as thrust bearing damage, particularly on double-suction impellers. Again, this is the eddy flow referred to in the reduced capacity paragraph of our handbook.

Published curves often show an operating characteristic from zero flow to well past the BEP flow. Some pumps should not be operated below 50-60 percent of BEP flow due to severe hydraulic instabilities resulting from the recirculation effects. The liquid recirculates within the impeller and the hydraulic channels so that the fluid particles have an opportunity to strike the vane surfaces a number of times before finally being discharged. This turbulent flow results in a situation that is often confused with "bubble" cavitation because it generates noise, and raising the suction head can result in some improvement. The turbulent flow, or recirculation, must be recognized for what it is because its end results can be much more destructive than cavitation. It is also much more common than may be expected [1,2,3,4].

What Are the Effects of Recirculation?

There are several destructive effects of recirculation.

1. *Impeller erosion*—the turbulent flows cause erosion of the impeller vanes on both the leading and trailing edges in a very short time.

2. *Impeller failure*—low frequency hydraulic pulsations may cause fracture-type failure of the shrouds or covers of the impeller. These pressure pulsations may be in the magnitude of 5-10 percent of the total head. An impeller structural failure may occur after only a few hours of operation at extremely low flows.

3. *High failure rates of mechanical seals*—the hydraulic pressure pulsations are very destructive to mechanical seals and may cause opening of the primary sealing faces.

4. *High bearing failure rate*—the pump rotor is moved by the hydraulic pulsations and can cause impacting failure of bearings, particularly thrust bearings, especially if there are other flow irregularities. In double suction pumps, the pulsations on each side are out of phase and can be at varying frequencies.

How to Recognize Recirculation

There are a number of practical considerations that must be understood to recognize recirculation troubles.

1. A low NPSHR of high suction specific speed impeller is much more susceptible than a normal design because of highly undesirable low flow characteristics. A calculation of suction specific speed is about the only predictive measure of the trouble. This will be discussed later.

2. Double-suction pumps are more vulnerable than single-suction, because flow disturbances are more common with this design due to casting problems.

3. Energy levels of 650 feet of head and 250 horsepower per stage are usually the lower limits of really serious recirculation problems, but even small pumps can be affected [1].

4. To suppress the destructive characteristics, a very high NPSH available is necessary. (1.8 to 2.0 NPSHA/NPSHR)

5. Recirculation is much more damaging with some liquids than with others. Pure liquids such as water are homogeneous and vaporization can occur instantaneously. In addition, water

has a high vapor-to-liquid volume ratio. A mixed chemical or petroleum liquid, composed of fractions that vaporize at different temperature and pressures will have a much less violent cavitation reaction. Narrow boiling range liquid hydrocarbons tend to react like water.

6. There are various design methods to prevent the onset of recirculation. However, all methods require an increase of NPSHR.

These considerations cause the traditional pump curves to be invalid because the unstable hydraulic characteristics can cause mechanical failures of the pump. Failure to understand these problems can lead to severe maintenance and operating troubles. Several disastrous fires have resulted from abrupt mechanical seal failures, shaft breakage, impeller fracturing, etc., of pumps.

Hydraulic Stability Guidelines

One measure of the hydraulic stability of a pump and its ability to operate away from design conditions is called "suction specific speed".

There are two specific speeds: discharge specific speed and suction specific speed.

"Discharge specific speed" (N_s) is a non-dimensional design index, to classify pump impellers as to their type and proportions. It is defined as the speed in revolutions per minute at which a geometrically similar impeller would operate, if it were of such a size as to deliver one gallon per minute against one foot head.

$$N_s = \frac{N \sqrt{Q}}{(H)^{3/4}} \tag{1}$$

where

- N = Pump speed in rpm
- Q = Capacity in gpm
- H = Total head per stage at the *best efficiency point* (BEP)

Note: For double suction impellers, the total flow should be divided by two, in calculating the specific speed.

The specific speed determines the general shape or class of the impeller. As the specific speed increases, the ratio of the impeller outlet diameter, D_2 , to the inlet or eye diameter, D_1 , decreases. This ratio becomes 1.0 for a true axial flow impeller.

Unlike discharge specific speed, suction specific speed is not a "type number," but a criterion of a pump's performance with regard to cavitation. The formula for suction specific speed is:

$$N_{ss} = \frac{N \sqrt{Q}}{(NPSHR)^{3/4}} \tag{2}$$

where

- N_{ss} = Suction specific speed (a "dimensionless" number)
- N = Rotative speed, rev./min. (rpm)
- Q = Pumping capacity, gal./min (gpm). Again use one half flow rate for double-section design.
- NPSHR = NPSH required, ft. of liquid at suction

ALL PARAMETERS MEASURED AT BEST EFFICIENCY POINT (BEP)

The suction specific speed yardstick was first proposed nearly forty-five years ago by Igor Karassik and others. Al-

though it was in the 1941 edition of "Marks Handbook", it is not in current handbooks. There are no accepted limits of N_{ss} for conservative versus maginal designs.

Jerry Hallam of Amoco presented the results of his research of several hundred pump failures over a 5-year period at a 1982 ASME Conference [5]. The pumps with high suction specific speeds (above 11,000) had a failure rate of approximately double that of the ones with lower ratings. The 11,000 limit appears to be a desirable maximum.

This work reemphasizes a paragraph from "Pump Curves Can Be Deceptive" [6].

Suction specific speeds above 10,000 should be avoided whenever possible. While higher suction specific speed impellers can be operated effectively, the operating range is narrowed to about 85 to 100 percent of BEP flow. This is too tight for industry operating practices. In other words, while it is technically correct that high suction specific speed pumps can be made to work, the loss of operating flexibility that goes with it is not acceptable unless an elaborate bypass system and other compensations are made to maintain flow.

Remedies for Existing Recirculation

If the pump is already installed, most of the corrective items discussed above are not available. Remedies are needed. The most effective remedy is to increase capacity beyond the range of rough operation, which in some instances may necessitate a fairly large bypass line from the pump discharge back to the suction source. While the first cost of the bypass line may be high, the cost of pumping the excess flow will generally be small, because the pump will be operating in a range of much better efficiencies. For very high specific speed pumps, an actual savings in pumping cost will result, because power requirements in such machines decrease with an increase in flow. In any event, the potential savings in maintenance costs is generally sufficient to justify the bypass [1] (Figure 2).

A better method for predicting the onset of recirculation has been presented by Warren Fraser [3, 10]. Reference to this paper will permit any pump user to predict and avoid problems in this area. Only a few mechanical measurements of the pump's liquid channels are required to enter into the simple equations. The Worthington group is to be commended for their making public this information.

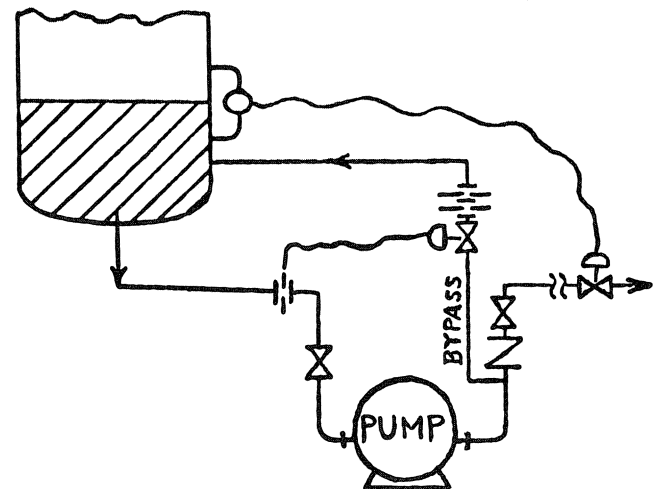

Figure 2. Simple Diagram, Automatic Minimum-Flow Bypass [1].

RADIAL HYDRAULIC FORCES

The form of the single volute case causes an uneven distribution of pressure around the periphery of the impeller which can cause a radial load perpendicular to the shaft axis. It varies directly with impeller width, diameter, and the pressure developed. The greatest radial load occurs at zero capacity, or shut-off. It decreases steadily as capacity increases and is near minimum at the BEP. It then increases again in the opposite direction, as capacity is increased from the BEP to full open discharge.

At about 50 and 120 percent of BEP flow, the direction of the deflection is at 90 degrees to the cut-water axis. The radial thrust unbalance increases bearing loads and shaft deflection, and should be taken into consideration when sizing the shaft. Most handbooks give the impression that, since double volute pumps have cut-waters diametrically opposed, the radial unbalance is in opposite directions at any given time, and therefore balances. Since the volutes are cast into the case and no machine work is done on them, they tend to have uneven surfaces and are irregular in shape. One volute is much longer than the other, causing uneven flows and pressure development. All of these factors combine to cause unequal radial hydraulic balancing. The theory of hydraulic balance in double volutes is faulty in the real live world. The irregularities can cause shaft deflection of a magnitude greater than the wearing ring clearances. This results in the rapid deterioration of the wearing rings, bearing failures, and shaft breakage due to fatigue failure of the shaft material.

Radial Clearances

Reduced impeller radial gap, combined with poor casting quality and recirculation at low flows, are the most frequent causes of impeller and diffuser/volute tip breakages. Many engineers believe that reduction of normal radial gap (gap "B," Figure 1) between impeller and diffuser/volute improves efficiency. Not only is this incorrect, but the reduced radial gap can cause failures.

As an impeller vane passes a stationary vane (diffuser tip, volute tongue or, as occasionally called, "cut-water"), a hydraulic shock occurs. This can be observed in the liquid, or noticed on rotor vibration. The distinct influence of the radial gap on pressure pulsation at vane-passing frequency and the radial forces generated is shown in many vibration analyses.

This vane-passing vibration can cause the following types of failures:

1. Impeller side-plate or shroud breakage is the most common result. Sometimes there is complete disintegration of the impeller, which completely camouflages the original cause of failure.
2. Diffuser (volute) inlet-tip breakage, can cause further mechanical damages to downstream pump components, such as control valves, etc.
3. Loosening of the impeller attachment not on single suction pumps along with fasteners such as seal housing bolts, etc.
4. Cracking of the pump casing.
5. Breakage of secondary piping components, such as a seal piping, drain and vent lines, etc.
6. Shaft breakage, generally outboard of the impeller in double-suction designs. Review of some shaft breakage cases disclosed several couplings that were damaged prior to shaft fatigue breakage. Use of a "soft" diaphragm coupling provided a temporary solution to avoid further shaft breakages.
7. Thrust bearing failures, especially in double-suction types which are designed for very low thrust loads.
8. High noise level from the pump, generated by the very

small radial gap.

9. High-pressure pulsation, on the order of 5 to 10 percent of the differential had developed, which possibly also causes malfunctioning of the control system.

10. Below-normal pump efficiency, with possible losses of as much as 5 percent.

11. If the pump is equipped with mechanical seals, a seal failure that requires costly replacement parts and, what is more important, unscheduled maintenance efforts can result.

Corrective Measures

Almost 45 years ago, R. T. Knapp recommended a 7 to 8 percent radial clearance for single volute pumps. More recently, Elemer Makay, working for Electric Power Research Institute, has refined those recommendations [7].

Careful machining of the volute or diffuser tips to increase gap "B" while maintaining gap "A" can reduce the vane-passing frequency greatly. Table 1 gives recommended dimensions for the radial gaps.

Table 1: Recommended Radial Gaps for Pumps

TYPE	GAP "A"	GAP "B"*—PERCENTAGE OF IMPELLER RADIUS		
		Minimum	Preferred	Maximum
Diffuser	50 mils	4%	6%	12%
Volute	50 mils	6%	10%	12%

$$*B = \frac{100 (R_3 - R_2)}{R_2}$$

R_3 = Radius of diffuser/volute inlet

R_2 = Radius of impeller

Note: If the number of impeller vanes and the number of diffuser/volute vanes are both even, the radial gap must be considerably larger (10 percent minimum).

The hydraulic forces can be reduced by 80 to 85 percent by increasing the radial gap from 1 to 6 percent. There is no loss of overall pump efficiency when the diffuser or volute inlet tips are recessed—contrary to the expectation of many pump designers. Any operation that shortens the diffuser or volute channels was believed to reduce efficiency. The observed efficiency maintenance results from the reduction of various energy-consuming phenomena: the high noise level, shock, and vibration generated with vane-passing frequency, and the stall generated at the diffuser inlet.

The hydraulic effect can also be reduced by the use of an odd number of impeller vanes with double volute pumps. The cut waters must be 180 degrees apart on a double volute. If the minimum clearances are not present in a pump, it will be necessary to grind away part of the cutwater of casing volute in order to gain the clearance. The cutwater should not be too blunt, but should be ground to about $\frac{3}{8}$ inch maximum width.

It is important to note that the clearance "B" is the vane tip clearance, not the impeller shroud clearance. As shown in Figure 1, it should be emphasized that while gap "B" controls the strength and amplitude of hydraulic shock created at vane passing frequencies, gap "A" controls the severity of pressure pulsation behind the impeller hub and shroud giving rise to high axial direction dynamic forces with distinct frequencies [4].

In addition to increasing the radial gap, more effective and reliable impellers can be achieved by several design changes [4].

1. Bring the impeller middle shroud plate out to the impeller O.D. to reinforce the impeller structure.

2. Stagger the right and left side of the vane to reduce hydraulic shocks and alter the vane-passing frequency.
3. Reduce clearances to optimum between shrouds and casing. (Gap "A")
4. Avoid even number of impeller vanes for double volute; or if the diffuser vanes are even numbered, increase the impeller side-wall thickness.
5. Impellers manufactured with blunt vane tips can also cause trouble by generating hydraulic "hammer" even when the impeller O.D. is the correct distance from the cut water. The blunt vane tips cause disturbance in the volute. This effect may be partly or entirely eliminated by tapering the vanes by "overfiling", or "underfiling" the trailing face.

Amoco has been adjusting gap "B" since 1966. Amoco's decisions were based on research done in 1938 by R. T. Knapp. Amoco's experience strongly supports the conclusions of Makay.

AXIAL HYDRAULIC THRUST

Axial thrust in single-stage process pumps is dependent on impeller design. There are four basic designs:

1. A closed type impeller with a full back shroud and an impeller eye wear ring—in this case, the area close to the shaft is open directly to discharge pressure, and the resultant pressure is quite high. However, the high velocity in the volute and the rotational effect of the liquid reduce the pressure somewhat, so that the pressure at the shaft and the wear ring is approximately seven-tenths of the total head plus suction pressure.

With smaller pumps, complete balance at all capacities is not necessary because of the smaller thrust load. A large enough ball bearing can handle any residual axial force that exists.

2. Radial ribs on the back shroud provide for handling some thrust action. This method is used with overhung impellers in process-type pumps. With this arrangement, pressure at the back shroud is reduced because liquid in the clearance must rotate at nearly impeller speed. There is no change in the pressure on the front shroud on the impeller. This method gives axial balance at only *one point* on the head-capacity curve.

Simplicity is supposed to be the chief advantage of ribs on the back shroud for balancing axial thrust. Actually the ribs complicate maintenance. Rib clearance must be held under 25 to 30 mils. The impeller must be repositioned axially as the ribs wear—a very difficult feat to accomplish. The stuffing box pressure is only slightly reduced from that of the impeller without the ribs. The design is not desirable because of high seal and bearing maintenance.

3. Another method of balancing the hydraulic axial forces

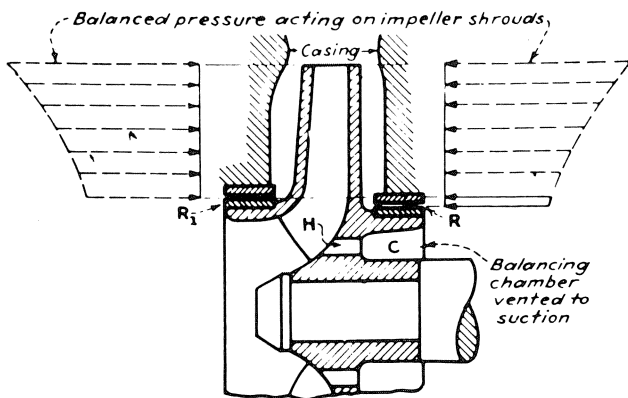

Figure 3. Hydraulic Axial Balancing of Impeller.

on a single-suction impeller uses wearing rings (R) on the back shroud and connects the enclosed chamber (C) inside the ring by holes (H) to suction pressure, as in Figure 3. Complete hydraulic balance is never fully attained for the pump's entire capacity range, even though the chamber is vented directly to the impeller's eye.

The back ring's diameter determines the amount and direction of the residual thrust. If the shaft runs through the eye, then back rings (R) have about the same diameter as front rings (R1). If the impeller is overhung, suction pressure must also be taken into account because a positive suction may develop an appreciable thrust toward the back shroud. To balance the thrust under these conditions, the diameter of the back ring must be reduced by an amount necessary to compensate for the thrust due to suction pressure on the shaft's end.

To obtain complete hydraulic axial balance with an overhung impeller, the suction pressure should determine its back wearing-ring diameter. As the impeller wears, the clearance increases; and the stuffing box pressure will go up as shown in Figure 4. The balance holes area should be at least twice the ring clearance area.

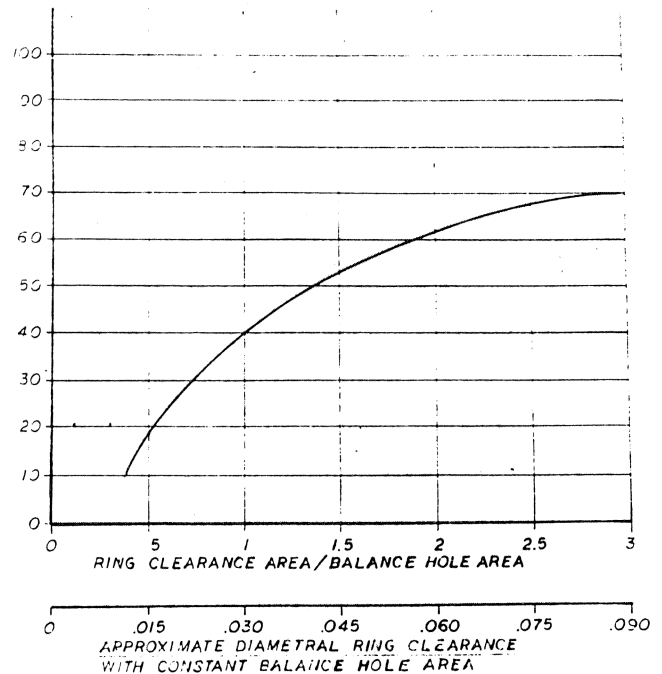

Figure 4. Ring Clearance Area/Balance Hole Area.

Wear on the rings increases the leakage through them and tends to reduce the pressure on the outside of the shrouds. If this wear is uniform on both sets of rings, the originally balanced areas will still be balanced since the pressure drop will affect both alike. Since leakage through the back ring has increased, pressure may build up in the balancing chamber and create a thrust toward the suction. As a result, the final effect of wear is dependent on the actual impeller used.

4. One way to reduce, but not eliminate, axial thrust is to mount impellers back to back. In effect, that is what a double-suction impeller is: two impellers are cast as an integral unit. Liquid entering the pump divides and flows into the impeller from opposite ends. The most common example of this arrangement is the horizontal split case double-suction pump (Figure 5). In this case, the stuffing box pressure is almost identical with suction pressure.

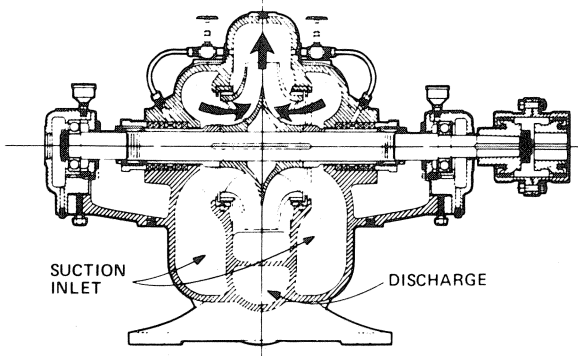

Figure 5. Double-Suction Pump.

Under ideal conditions, the hydraulic axial forces acting on one side of the impeller balance those on the other, and there is no thrust. In actual operation, however, thrust develops because of a number of factors:

1. When either side of the suction becomes partly obstructed. The flow is then no longer equally distributed between the sides of the impeller, and the hydraulic axial forces become unbalanced (Figure 6).
2. If the casing is not symmetrical on both sides of the impeller.
3. A horizontal elbow at the suction can cause unsymmetrical flow (Figure 7).
4. Recirculation caused by operating at reduced flows (below about 60 percent of Best Efficiency Point) can cause axial hydraulic unbalance, and worse yet, an alternating thrust action which can destroy the bearings by impact loading.

In large pumps, impeller eye areas are so large that one or two pounds' difference in the suction pressures on the two sides can easily produce a thrust of 400 pounds. For these reasons, double-suction pumps require thrust bearings of ample size.

If the flow remains evenly divided between two sides of a double-suction impeller, wear has little effect in throwing the hydraulic axial forces out of balance. If both sets of wear rings do not wear alike, more leakage flows through one than the other to cause an unbalance of the hydraulic axial forces. Pressure will be lowest on the shroud adjacent to the greatest

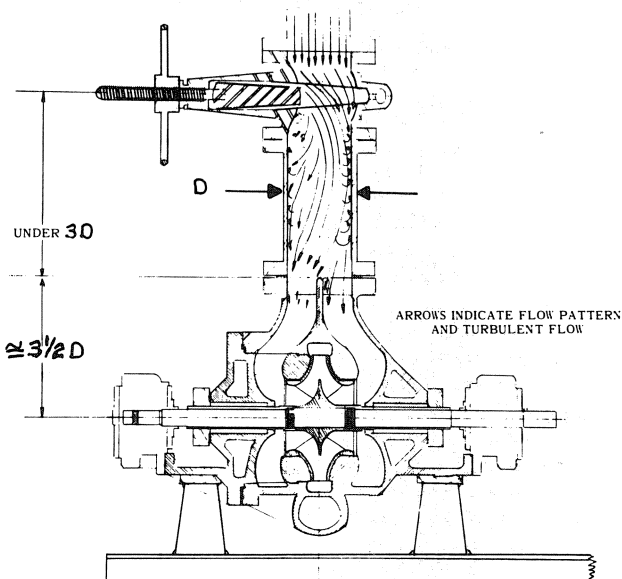

Figure 6. Effect of Valve Orientation of Suction Conditions.

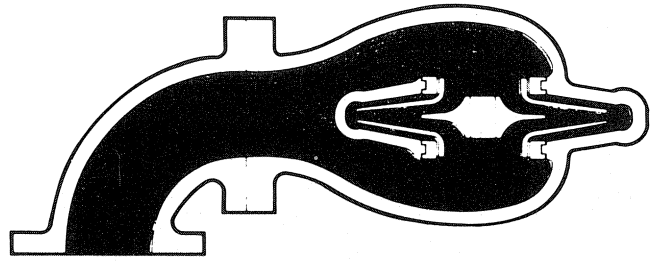

Figure 7. Effect of Elbow Directly of Suction Conditions.

leakage with a consequent thrust in that direction. Wear rings should be the same diameters and clearance.

Complete axial hydraulic balance is *never* achieved in any pump design. Poor maintenance practices such as unequal wearing clearances, poor suction piping design, low flows, etc., all can create thrust actions in a single-stage pump. If the thrust bearing is not large enough, a pump or seal failure results.

MECHANICAL FEATURES

Purpose of Bearings

The ball bearings usually found in a single-stage pump must (1) allow the shaft to rotate with practically negligible friction; (2) hold the rotating element in its proper position relative to the stationary parts of the pump, both radially and axially, so that rubbing cannot occur; (3) must be able to absorb the pulsating forces that are transmitted to them from the impeller; and (4) give trouble-free service for long periods of time.

In addition to the hydraulic load transmitted to the bearings, there are radical mechanical loads from other sources. The weight of the rotating assembly—shaft, sleeve, and impeller gives one load. Imbalance and shaft misalignment give still another.

The life of a bearing is dependent upon the load that it must carry and the speed of operation. In any two-bearing system, one of the bearings must be fixed axially, while the other is free to slide. This arrangement allows the shaft to expand or contract without imposing axial load on bearings, and yet definitely locates one end of the shaft relative to the stationary parts of the pump. The outboard bearing (the closest one to the coupling in a back entry style) is fixed axially. The inboard bearing is free to slide within the housing bore to accommodate thermal expansion and contraction of the shaft. In a double-suction, between bearing design, the coupling end bearing floats and the outboard bearing is fixed.

Since the outboard bearing is fixed in the housing, it must carry the axial thrust in addition to radial thrust. The axial thrust is considered to be acting along the centerline of the shaft, and therefore, is the same at the outboard bearing as it is at the impeller. The radial and axial loads combine to create a resultant angular load at the outboard bearing.

Radial hydraulic forces acting on the impeller creates radial loadings on both bearings. The magnitude of the radial load at each bearing can be determined by the use of the following equations and dimensions shown in Figure 8.

$$\begin{aligned}
 R_1 &= \frac{Pa}{s} = \frac{P(10'')}{10''} = P \\
 R_2 &= \frac{P(a+s)}{s} = \frac{P(10'' + 10'')}{10''} = 2P
 \end{aligned}
 \tag{3}$$

where:

- R = radial mechanical load at bearings 1 and 2 in pounds
- P = radial hydraulic load on impeller in pounds
- a & s = dimensions shown

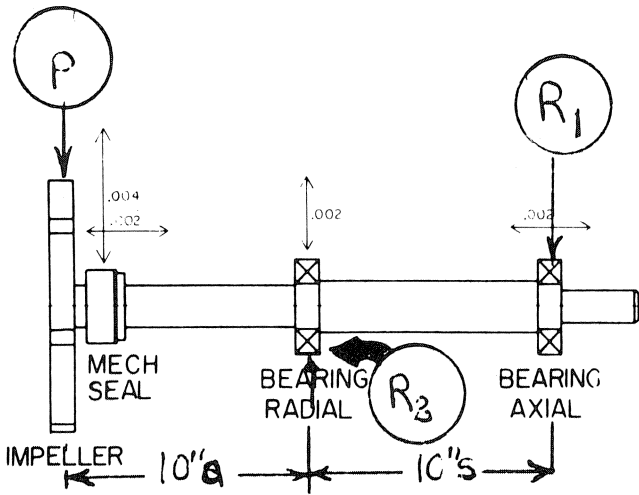

Figure 8. Bearing Loads.

Good pump designs limit the shaft deflections at the stuffing box face to within 2 mils at the worst conditions. For single-stage, horizontal end suction pumps, this will be the maximum impeller and at “shut-off,” i.e., closed discharge conditions. For larger double-suction pumps, this load might well occur at the far right end of the performance curve. Attention paid to impeller to cutwater clearances and “overfilling” of vanes can reduce this load to a minimum.

Ball Bearing Types

Many types of ball bearings are available to industry. Ball bearings are classified according to type of loading: radial, thrust and combined loading. Radial bearings are designed for loading at right angles to the axis of rotation. Combined loading bearings are designed for a combination of radial and thrust loading. Some bearings are suitable for any of these loads; others are designed for only one kind.

Size and class of precision of bearings are governed by the Anti-Friction Bearing Manufacturing Association (AFBMA) and by the Annular Bearing Engineers Committee (ABEC). There are five ABEC Classes, 1, 3, 5, 7 and 9. Class 1 is Standard and Class 9 is High Precision. Pump bearings are Class 1. ABEC Class 9 is factory order only and has no longer bearing life or higher speed rating than ABEC 1.

API 610, Sixth Edition, specifies that single row or double row radial bearings be Conrad type. The Conrad type (identified also by its design features as the deep-groove or non-filling slot type) is the most widely used ball bearing. Its deep-groove raceways permit this bearing to carry not only radial loading, for which it is primarily designed, but almost an equal amount of thrust load in either direction, in combination with the radial load. Speed characteristics are good, too.

API 610 require the deep groove Conrad type single row radial bearings with a Class 3 or loose fit. This permits flexibility to let the shaft correct for any misalignment between the housing and the shaft. Internal clearance is independent of class or precision.

The prohibition against the maximum capacity type stems from poor experience with this type. The maximum capacity or

filling slot bearing is provided with a filling notch that extends through the ring shoulders to the raceway, and permits a larger number of balls to be placed between the rings that can be done in the same size Conrad-type bearing. The supposed advantage of filling slot bearings (larger load carrying capacity) had vanished with the availability of better steels and lubricants. Filling slots often are not precision machined and can enter the ball contact area. This will result in early bearing failure. Several bearing manufacturers consider a filling slot bearing to be unreliable and recommend against their use.

The Sixth Edition also requires that ball type thrust bearings be dual (or duplex) single row angular-contact (7000 series) with a 40 degree contact angle (0.7 radian) with a light (100 pounds or 45 KG) preload.

Conceptually, duplex bearings are identical single-row bearings placed side by side. The contacting surfaces must be specially ground to generate a specified preload with a controlled relationship between the axial location of the inner and outer ring faces. This special grinding allows the two bearings to share loads equally. Without it, one bearing in the pair would be overloaded, the other underloaded.

Rigidity of the shaft and bearing assembly depends in part on the moment arm between ball-contact angles of the duplex bearings. Within reasonable limits, the longer the moment arm, the greater its resistance to misalignment.

DB bearings are intended only for back-to-back mounting. They are placed so that the stamped backs of the outer rings are together. In this position, the ball-contact angles diverge outwardly, away from the bearing axis. With DB bearings, the space between the diverging contact angles is long: shaft rigidity is correspondingly increased and resistance to misalignment is increased.

DF bearings are intended only for face-to-face mounting. They are placed so that the faces, (or low shoulders) of the outer rings are together. Ball-contact angles converge inwardly, toward the bearing axis.

With DF bearings, space between the converging contact angles is short; shaft rigidity is relatively low. However, this arrangement permits a greater degree of shaft misalignment than other mounting methods.

Heavy black bars in Figure 9 represent the moment arms obtained from two common bearing arrangements. In general, the longer the moment arm, the stiffer the assembly. Left: DF of face-to-face bearings provide a short moment arm, low stiffness, but relatively high tolerance to misalignment. Right: DB or back-to-back bearings have longer moment arm, higher stiffness, and greater resistance to misalignment.

While the requirement of a 7000 series, 40 degree contact angle, light preload bearing should like a fairly tight specification, it is not. First, there are three 7000 series bearings designs; light, medium, and heavy. Second, there are several contact angles used by some manufacturers. The contact angle is the source of considerable confusion as shown in Table 2. There is no standard designation to identify the 40 degree angle.

Table 2. Contact Angles for 7000 Series Duplex Bearings.

Bearing Manufacturer	Contact Angle				
	20°	25°	30°	35°	40°
Company A	X			X	X
Company B			X		X
Company C		X		X	
Company D					X

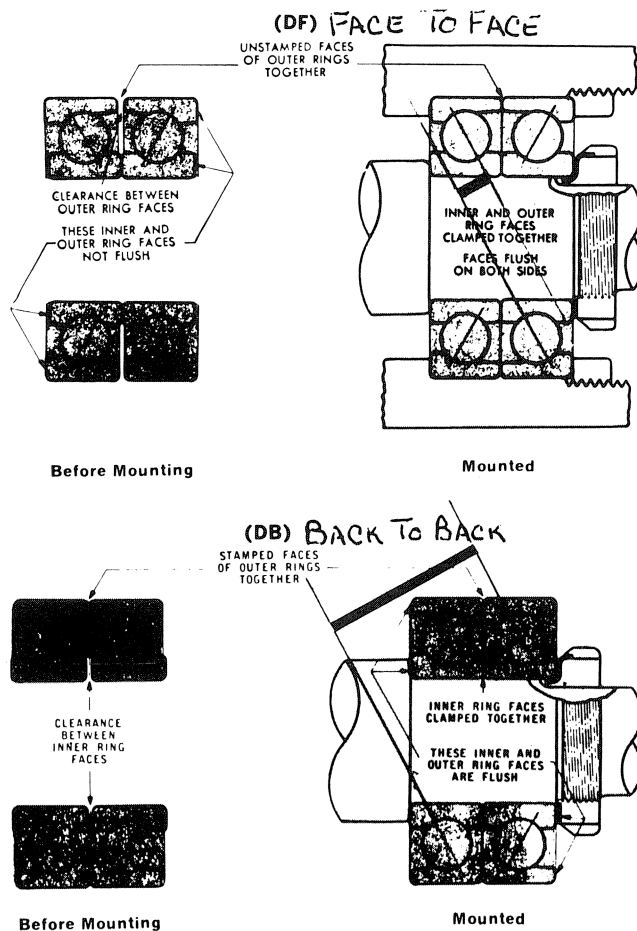

Figure 9a,b. Mounting Moment Arms.

Only three U.S. ball bearing companies manufacture the 40 degree angle (one of them only began the practice in 1983). If the local bearing supply house is not on its toes, your pump repairs may be made with non-specification bearings. The 40 degree contact angle gives a 18 to 40 percent capacity increase over the 30 degree angle depending on bearing size. This capacity change is a very important piece of information to be communicated by a confusion of suffixes. The numerical code used in bearing identification is mostly standard among the various bearing manufacturers. However, the alphabetical prefixes and suffixes are not. Care should be exercised when identifying bearings from codes for the purpose of interchanging bearings that the meaning of all numbers and letters is determined, so that an exact substitution can be made. Most manufacturers supply cross-reference tables for identifying equivalent bearings and a very good source is the bearing manual of the AFBMA (Anti-Friction Bearing Manufacturers Association).

While double-row bearings can be constructed to be angular contact designs, they are considerably more vulnerable to failure in thrust applications and should be avoided. The use of the double-row radial bearing in conjunction with angular contact thrust bearings should be avoided due to extreme rigidity of this bearing system.

Other Bearing Problems

A retainer ring (or cage) is used to make all the balls of a bearing go through the load zone. The most common retainer material is low carbon steel (1010 analysis) attached by fingers, rivets or spot welding.

Riveted or spot welded steel strip cages are subject to fatigue failures. When a bearing ring is misaligned, the balls are driven up against the race shoulder, the top ball to the left and the bottom ball to the right. The center balls on each side, at this particular point, tend to stay in the center of the races because balls in this position relative to the misalignment are not thrust-loaded. The net effect of this action is to flex the race in plane bending. As the inner race turns, a cyclic cage bending stress occurs. The load on the cage packet is also cyclic. At the high thrust loads, the cage exerts the maximum force in maintaining the ball space. Since the cage and ball are in rubbing contact, the highest thermal load becomes a minimum at the side (no thrust load points). In this manner, the cage is subjected to both a flexing and thermal cyclic load that can lead to fatigue cracking at cage stress points such as forming notches and rivet holes. Due to the rubbing contact between the cages and balls, the lubrication requirements here are more critical than for the rolling contact between the balls and races. Shock loading of the bearings also cause failure at the pockets.

Some manufacturers use pressed brass, machined bronze, machined phenolic and molded plastics in an effort to reduce the heat generation.

One bearing company is gradually switching many of their ball bearings over to 30 percent glass-filled nylon separators containing 5 percent molybdenum disulfide. This allows a bearing to run with up to double the misalignment (30 minutes versus 15 minutes of arc), produce lower torque, run quieter and with less heat buildup and to withstand more vibration. Desirability of bearing separator types, in my opinion, is as follows: (1) glass-filled nylon, (2) phenolic, (3) machined bronze, (4) pressed brass strips, (5) pressed steel strips, and (6) riveted steel strips.

HOT OIL PUMPS

Pump Casing Design

The purpose of the pump casing is (1) to guide the liquid to the impeller, (2) convert into pressure the high velocity of the flow from the impeller discharge, and (3) lead the flow away from the impeller to the discharge nozzle. Impeller design frequently dictates casing design.

Pumps for high pressure and high temperature service are usually supplied with a vertically split casing. This is a casing which is split perpendicular to the shaft axis. The American Petroleum Institute specifications for pumps (API 610) require a vertically split casing when either or both of the following exists: (1) the operating temperature is above 400°F, and (2) the product is flammable or toxic with specific gravity less than 0.7. The casings are designed so that the openings have circular confined gaskets, either soft aluminum or spiral wound (flexitallic) type. The design of a single-stage double-suction between bearings pump with a cast head on one side and a removable head on the outboard side, with two circular gaskets, one between the suction and discharge chambers and one between the suction chamber and the atmosphere is shown in Figure 10. This type pump generally has an approximately 27 percent lower NPSH required than the end suction, overhung impeller normally associated with process pumps. This design also presents some inherent maintenance problems.

Problems with Vertically Split Between Bearings Pumps

1. *Bearing Alignment*—in horizontally split, lower pressure between bearings pumps, the bearing brackets are normally an integral part of the lower case half and are not disturbed during disassembly procedures. In vertically split designs, the bearing brackets are bolted to the heads. Both bearing bracket (Part

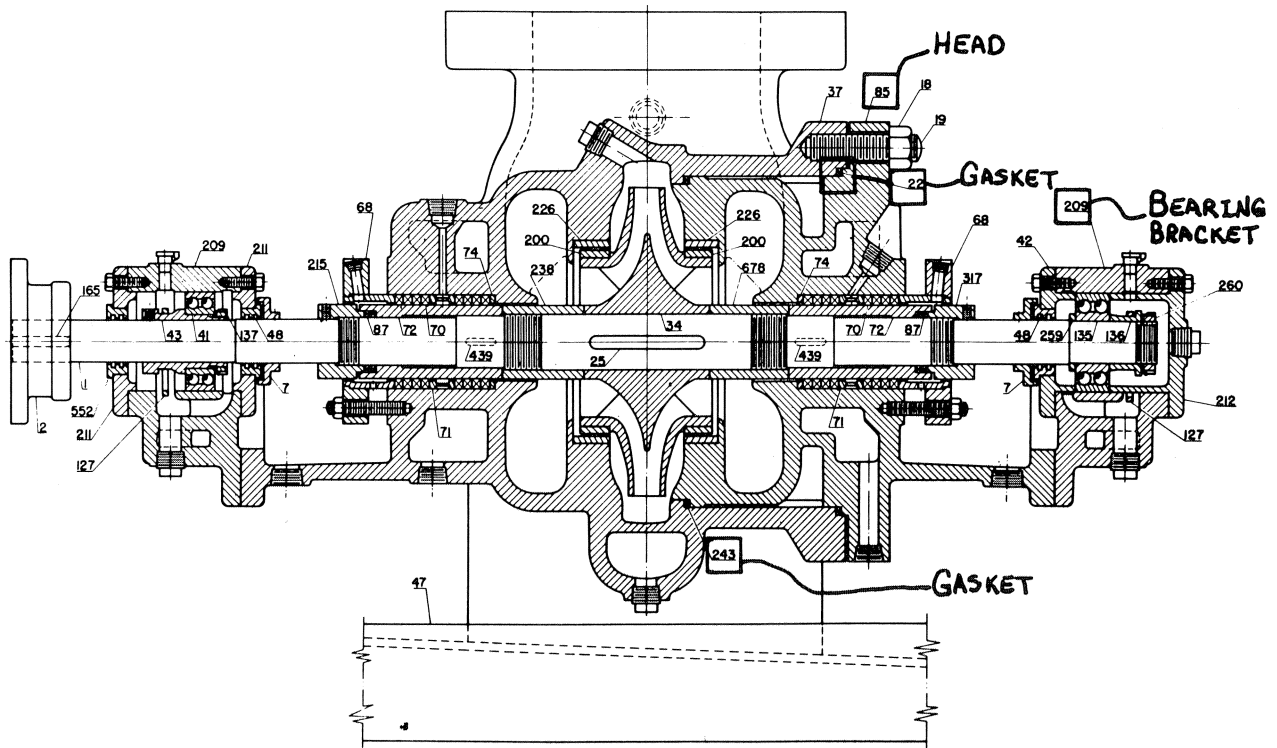

Figure 10. Radially Split Pump.

209) and the head (or heads) (Part 85) of Figure 10 are removed during disassembly operation, thus requiring *all* internal alignment to be reestablished each time maintenance work is performed. This is a time-consuming and exacting procedure that is not spelled out in maintenance manuals.

2. *Inner Casing Alignment*—the liquid path of a vertically split pump consists of an inner casing guide or diaphragm that is contained within the pressure walls of the casing. Alignment of this inner guide or diaphragm is very difficult. In Figure 10, this is cast into the head. In some cases it is a separate piece.

3. *Internal Leakage*—the high pressure (discharge) and low pressure (suction) compartments of the inner diaphragm are separated by a *single* invisible gasket. Because the diaphragm does not fit tightly in the casing bore, the gasket may not function properly, permitting internal leakage. In addition, the gasket is frequently damaged as it passes across the suction nozzle opening in the casing, a condition that is hard to avoid and equally hard to detect if it occurs. It is also hard to compress each gasket equally.

4. *Thermal Distortion of Casing*—heat distortion imposes a severe strain on a pump shaft and bearings and usually results in permanent damage. Uneven head expansion of the pump case is the most serious cause of mechanical failures in hot oil pumps.

5. *Casing Distortion Due to Pipe Strain*—the pump case carries the bearing housings, thus any distortion of the outer shell due to excessive pipe strain is reflected in the location of the rotating element.

While items 1, 2 and 3 are largely dependent on assembly techniques, items 4 and 5 need some discussion.

Thermal Distortion

Thermal expansion of pumps is complex. Thermal growth can cause vertical and horizontal misalignment that are accommodated by the coupling. Internal misalignment can also result

because of the thermal growth. The casing grows away from the support while the rotor grows toward the support. Since the thrust bearing is in the casing, part of the rotor growth is cancelled out. Control of this growth is very important to alignment, both internal and external.

Typical casing support and alignment provisions for the thermal casing expansions are shown in Figure 11. The suction end of the casing is mounted on two “sliding foot” supports (also commonly called “grease plates”) where a transverse key anchors the axial centerline position of the suction relative to the piping while allowing transverse expansion of the suction along the keyway. In addition, there is also a sliding key on the vertical centerline which fixes the vertical centerline, relative to the foundation. Since the elevation of the support feet is near the horizontal joint, a “true centerline support” concept of the rotor and casing is maintained during operation. The concept of supporting a casing at its horizontal joint centerline is an important one in that maintaining the concentricity clearances of the casing parts relative to the rotor.

Improperly maintained sliding feet can generate tremendous casing forces if sliding is not achieved while the casing expands and could result in casing “humping” or failure in severe instances. The sliding joint itself reduces the overall

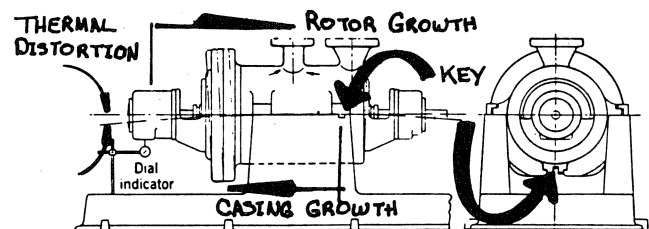

Figure 11. Casing Distortion When Starting Cold Pump on Hot Oil.

stiffness gradient through the support, which relies only on gravity loading for contact, and does not have equal stiffness for upward versus downward forces.

The heat expansion of pump parts can affect the mechanical performance of the pump in several ways:

1. Frequently, the parts of the rotating element are of different materials than the pump case, and the running clearances may be reduced below a safe minimum.

2. Shaft sleeves, impeller rings, and case wearing rings, which are tightly fitted, may become loose when hot because of a difference in expansion.

3. The rotating element may get out of alignment when the case is hot, because of heat distortion of the case. Uneven heat expansion of the pump case is a frequent cause of mechanical failures. If the pump is put on stream cold when starting a run and is brought up to temperature gradually during several hours, there is sufficient time for all parts to reach the same temperature, and no case distortion results. However, if hot oil is charged to the pump suddenly, the various pump parts do not reach the same temperature at the same time. Usually, the upper part of the outer case reaches its highest temperature an hour or more before the bottom because the flow tends to be in the top of the pump.

4. The diaphragm plate separating the suction chamber from the discharge casing is closely fitted into the case (Figure 10). The temperature of the diaphragm will be equal to that of the hot oil and that of the casing can be several degrees lower. The expansion of the diaphragm, being restricted by the cooler casing, may result in compression of the diaphragm and tension in the casing. When cold, the diaphragm will be loose in the casing. If the joint between the volute casing and suction chamber is made without a gasket, loss of capacity will result. Many hot oil pumps are not gasketed at this area of the head.

These examples emphasize again the importance of insulation on hot-oil pumps, not to conserve heat but to assure satisfactory mechanical operation of the pump. There are no sure fire methods of warming up a hot oil pump before placing it in service, but the following steps are good starting points [8].

1. Hot oil should be circulated through the case of a spare pump to keep it ready for starting on hot oil in case of an emergency.
2. Oil circulation should be provided through the *bottom* of the case during the starting period by means of by-passes from the bottom of the case to the pump suction.
3. The pump case should be well insulated to reduce and equalize loss of heat from the outer casing to the atmosphere.
4. Where it is intended that a pump shall operate over 150°F, it is *mandatory* that it be prewarmed to a temperature approaching that of the product to be pumped.
5. For best service life, all parts of the pump casing should be brought to within 50 to 75°F of one another. Until this state is reached, the casing is distorted due to thermal growth and may temporarily reduce required internal running clearances. This condition is most common where improper injection of warming streams has occurred and the casing has not warmed evenly.
6. Generally, pumps with 10 inch discharge nozzles and larger have three drains, all of which must have warm-up circulation. Total time for warmup varies from approximately two hours to as high as eight hours. Total time is influenced by the temperature of pumped product, pump size, insulation system, temperature, and rate of flow of warming stream, and point at which warming stream is introduced into pump.

Pipe Strain Distortion of Casing

The casing of a single-stage double-suction pump is especially susceptible to pipe strain. In looking at an end view of the pump, (Figure 12) it looks like the wishbone of a turkey. Pipe strain tends to *close* the "wishbone" which in turn "crushes" the casing wear rings in the vertical plane. In some pumps, the case supports are inside the outer dimension of flanges; then the pipe strains tends to open the "wishbone" and crush the ring in a vertical direction, rather than the horizontal direction.

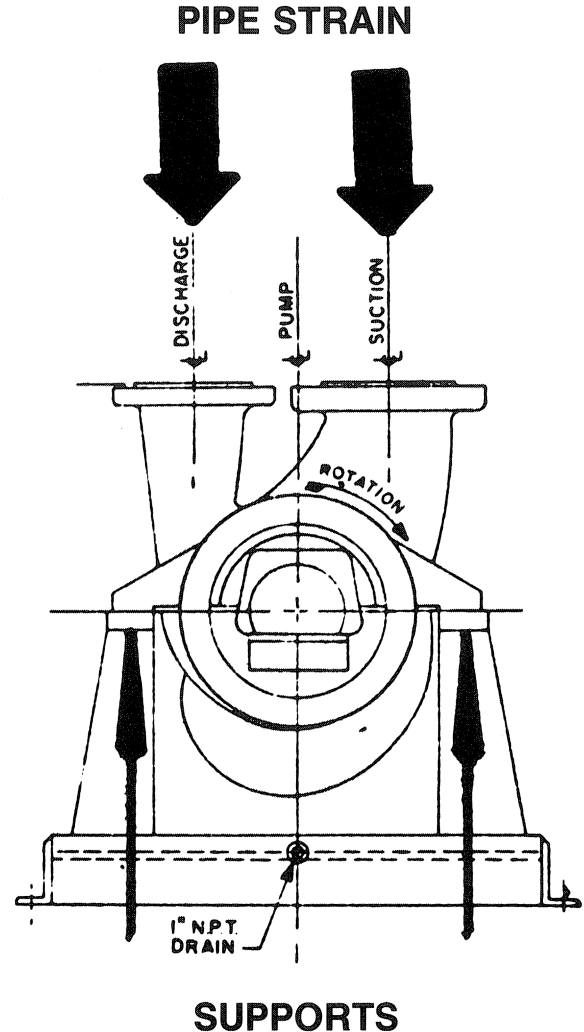

Figure 12. Pump Casing Distortion Due to Pipe Strain.

Use of Dowel Pins

Internal alignment problems can arise after a severe failure of the bearings. Replacement shafts and the bearing bracket clearances frequently are built up with weld metal and machined. Proper running clearances are established for the shaft, bearings, and deflector in the shop. If the old dowels were used for final positioning of the bearing housing, misalignment of the bearing housing to the shaft can be created, resulting in the loss of clearances and failure of the bearings. *Never rely on the dowels to align a bearing housing after it has been removed from the pump or turbine.* Always check clearances in the field with feeler gages, or check the "lift" of the rotor without the seals or packing in place. Determine the lift and check dowel

holes alignment when the rotor is centered. Ream the holes to ensure a good fit.

PIPING DESIGN

Vortexing

A vortex is a swirling or funneling action in a liquid. When this occurs between the liquid's surface and the drawoff nozzle in a vessel or basin, air or vapor can be drawn into a pump. The formation of a vortex can be very damaging, because vortexing effectively reduces the NPSH available. With the suction head of a pump close to a minimum value, air or vapor entrainment is likely to occur. Only 2 percent air entrainment can result in a 10 percent loss in pump capacity. In these cases, a term frequently called "submergence" comes into play. Submergence and NPSH are not the same. It is possible to have adequate submergence and insufficient NPSH, or the reverse. A proposed installation must be checked for both adequate submergence and for NPSH equal to or greater than that required by the pump.

To avoid vortex formation, different precautions must be taken according to pump design. The Hydraulic Institute Standards, Thirteenth Edition, has an extensive treatment of pumping systems where the pump is located at or in the source of liquid. In these cases only a simple suction line is needed, yet we frequently make installation errors. Greater attention to established guidelines is needed in sump design.

Cooling Water Pumps

Most refinery cooling water pumps are non-API designs, but the problems typified with their installations are frequently encountered in process systems. A typical example of the suction piping for a cooling tower water pump is shown in Figure 13. The water level in the cooling tower basin determines the basin's height and cost. Consequently, a minimum water level is preferred, but the level must be sufficient to meet the pump's NPSH. Design of the suction piping is critical since submergence is a greater factor than NPSHR in good pump performance for this situation.

To prevent air entrainment and vortexing, a baffle or spoon bill is needed. We are accustomed to spoon bills in storage tanks, but we don't think to use them in cooling towers.

The eccentric reducer is placed in the line with the flat side up in order to avoid an air pocket. A butterfly valve which is frequently used because of little resistance and no air pockets in the housing is shown in Figure 13. The vortex breaker is essential. It can be as simple as the flat plate in the sketch.

Vertical Pumps

A submerged vertical pump has no suction piping. Manufacturers of such a pump require a minimum submergence to prevent vortex formation. Greater submergence is needed if the

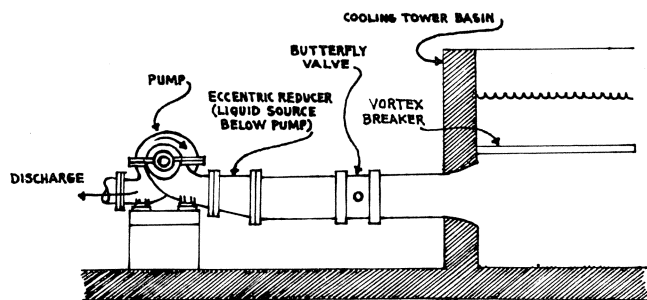

Figure 13. Suction Piping for Cooling Water Pumps.

pump has no inlet strainer as the strainer acts as a vortex breaker. Submerged pumps should have an adequately sized suction sump. Baffles are needed if two or more pumps are in a row. The "Hydraulic Institute Standards" [9] provide recommended practices for sump design, yet many designers continue to ignore this need.

The barrel of a vertical "canned" pump serves as an annular suction pipe. With this configuration, vortex forming is unlikely.

Process Systems

A majority of the hydraulic troubles that occur with centrifugal process pumps are associated with problems on the suction side because of poor design, manufacture, or application of the pump itself. A frequently overlooked source of trouble is the suction piping design. In most cases, there is an extensive suction piping system between the tower or drum and the pump. The basis of much piping design is pipe rack layout convenience, not the assurance of a steady flow of liquid to the pump suction to (1) meet or exceed NPSHR of the impeller pattern; (2) have a uniform velocity profile and; (3) have a minimum rotation velocity component of the entering liquid. Suction piping problems increase rapidly with pump size and a high suction specific speed index (i.e., low NPSHR).

Most process pumps take suction on a liquid source above them such as the side or bottom of a tower or drum. It is very important that there is adequate submergence level over the inlet to the suction pipe, to prevent vortexing. Sometimes a vortex may arise because the liquid level in the process vessel becomes very low or the velocity in the piping becomes very high.

Mechanical vortex breakers, as shown in Figure 14, at the suction inlet can reduce rotation velocities, but are not effective against vapor entrainment.

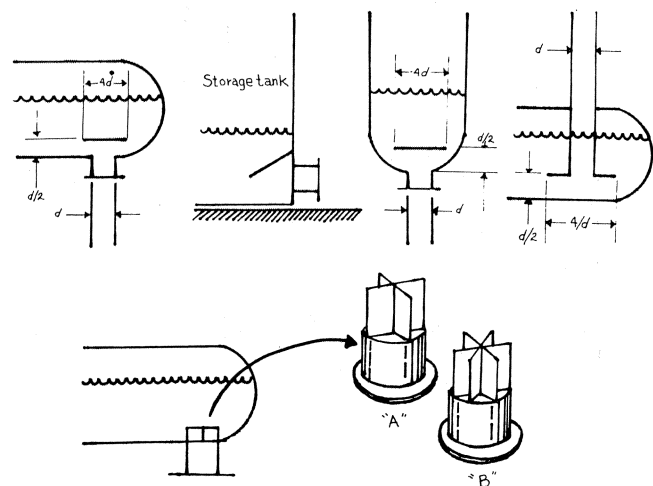

Figure 14. Mechanical Vortex Breaker Guidelines.

If these devices are damaged or omitted during tower repairs, and a vortex occurs, the real suction head is considerably lowered. Submergence is a function of liquid height over the inlet to the velocity at that point. If the liquid level cannot be raised, the size of the inlet must be increased.

As the suction piping layout at the pump becomes more complicated, the liquid velocities must be reduced. If this is not possible, the submergence must be increased. More submergence for hydrocarbons than water is recommended by many experts (Figure 15).

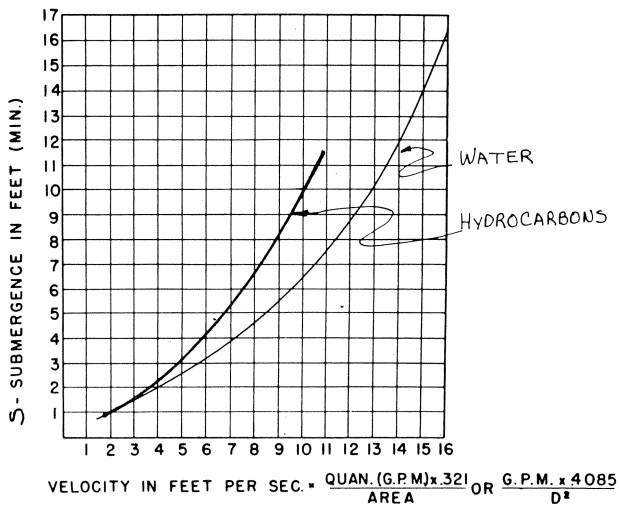

Figure 15. Recommended Minimum Submergence vs. Velocity.

Some other factors of the piping design must be considered:

1. Reducer size changes should be limited to one size change (10 inches to 12 inches).
2. Concentric reducers are better with end-suction pumps.
3. With double-suction between bearing designs, an eccentric reducer with the flat side down—this is contrary to the liquid below the pump situation.
4. A straight-suction piping run of 5 to 10 pipe diameters is desirable.
5. Straightening vanes should be considered, if straight pipe sections cannot be provided.

The suction specific speed index of the pump should be considered in suction piping design. The suction conditions of a

pump do not start and stop at the case nozzle, but rather extend all the way back to the liquid level of the vessel.

REFERENCES

1. Taylor, I., "The Most Persistent Pump-Application Problem for Petroleum and Power Engineers," ASME, Paper 77-Pet-5, presented in Houston, Texas (1977).
2. Bush, A. R., Fraser, W. H., and Karassik, I. J., "Coking with Pumps Progress: The Sources and Solutions of Centrifugal Pump Pulsations, Surges and Vibrations, Treating Internal Recirculation," *Pump World*, Worthington Pumps (1976).
3. Fraser, W. H., "Flow Recirculation in Centrifugal Pumps," *Tenth Annual Turbomachinery Symposium Proceedings*, Texas A & M University (1981).
4. Makey, E., "Survey of Feed Pump Outages," FP-754, Research Project 641.
5. Hallam, J. L., "Centrifugal Pumps: Which Suction Specific Speeds Are Acceptable," *Hydrocarbon Processing* (April 1982).
6. Nelson, W. E., "Pump Curves Can Be Deceptive," NPRA Refinery and Petrochemical Plant Maintenance Conference, San Antonio, Texas (1980).
7. Makay, E. and Diaz-Tous, I. A., "Feed Pump Reliability and Efficiency Improvements Resulting from Hardware Modifications," EPRI Conference, Cherry Hill, New Jersey (1982).
8. Stepanoff, A. J., *Centrifugal and Axial Flow Pumps*, John Wiley & Sons, Inc. (1957).
9. *Hydraulic Institute Standards*, Thirteenth Edition.
10. Fraser, W. H., "Recirculation in Centrifugal Pumps," presented at Winter Annual Meeting of the ASME (1981).