

IMPROVING PUMP RELIABILITY IN LIGHT HYDROCARBON AND CONDENSATE SERVICE WITH METAL FILLED GRAPHITE WEAR PARTS

by

Robert P. Komin

Engineering Sales Representative

Graphite Metallizing Corporation

Beaverton, Oregon



Robert P. Komin has worked for Graphite Metallizing Corporation for eight years. He is the West Coast Engineering Sales Representative.

Prior to joining Graphite Metallizing in 1981, Mr. Komin was an Assistance Chief Engineer with Sulzer Bingham Pumps, Incorporated. His area of responsibility was Bingham's vertical pump line. In that capacity, he testified, as a pump and bearing expert before the Nuclear Regulatory

Commission in Washington D.C. with regard to the safety and reliability of the vertical pump in nuclear power plants. He also worked for Johnston Pump Company and Peerless Pump companies. He has spent over 25 years working directly in the pump industry.

He was the speaker at the Pacific Energy Association, PEA Pacific Northwest Chapter's Pump Workshops, and for the Western Gas Processors and Oil Refiners Association Pump Workshop.

Mr. Komin attended Portland State University. He is a member of ASME, and of the Pacific Energy Association.

ABSTRACT

A number of single stage overhung and multistage horizontal pumps with a history of dry running seizure have been modified by replacing the metal stationary wear parts with metal filled graphite. After modification, the operational life of these "problem pumps" have been extended two to four times and the repair cost has been reduced by approximately one third to one half of the metal fitted pump.

INTRODUCTION

Recent operating practices in hydrocarbon processing, auxiliary feed and boiler feedwater service have placed severe demands on the traditional horizontal pump. This has resulted in increased failure rates, with more down time and higher maintenance costs for the pump user. Typical problems have been dry running pumps with subsequent galling of wear surfaces and pumps subjected to rapid temperature transients which result in galling and seizure.

The single stage overhung and the multistage horizontal pump require a flow of pumpage through the "bushing sleeve" annulus and the "case ring impeller" annulus to support and center the rotating element. If the flow of pumpage is interrupted due to insufficient NPSH, the pumpage flashing or a system upset, the rotating element will sag due to its own weight and could contact the stationary members. When the stationary members are of similar material, such as the standard combina-

tion of chrome impeller rings and case rings, the members will weld when they touch. In general, when identical metals made contact while running dry, welding will take place at a series of isolated points.

If sufficient force is developed by the rotating member, the welds are torn loose, leaving a rough surface at which welding is almost immediately repeated until the rotating element can no longer tear itself loose and seizure occurs.

BACKGROUND OF DEVELOPMENT

For many years, metal filled graphite has been the standard vertical pump bushing material in both light hydrocarbon and heater drain, hot well and condensate service. Metal filled graphite is used because of its unique properties of self lubrication, chemical resistance, dimensional stability, resistance to high differential erosion and its high load carrying capacity.

Initially, the thought of using metal filled graphite as stationary members, both as case rings and bushings, raised concerns whether the material could withstand the rigorous conditions. Conditions such as the high rotational speed of the element with high pressure differentials are found in a horizontal pump. After more than five years of field experience, in a multitude of installations, the main limiting factor to the use of metal filled graphite has not been peripheral speed or high differential pressure, but rather abrasive particles in the pumpage. This conclusion was not unexpected as abrasive particles have also been a limiting factor in vertical pump bushing applications.

RUNNING CLEARANCE

Pump running clearances are often dictated by the necessity to avoid contact of the rotating element with the stationary wear parts. Large running clearances penalize hydraulic efficiency, by allowing excessive internal leakage. Since metal filled graphite is a self lubricating material, running clearances can be significantly reduced, thereby improving pump efficiency and rotor stability without risking seizure of the rotating element. Refer to Table 1 for a comparison of recommended running clearances.

EROSION (WIRE DRAWING)

Metal filled graphite has successfully functioned as high pressure breakdown bushings and as case wear rings where substantial pressure differentials are developed. Erosion (wire drawing) has not been found to be a serious problem. However, pressure differentials across metal filled graphite must be minimized where gritty and abrasive particles are present in the pumpage.

The data in Figure 1, illustrating the relationship of differential pressure and peripheral speed to bushing and/or case wearing ring length, were plotted using field data from Table 2, all values used in establishing this curve, have been extrapolated from pumps that have been in service for a minimum of one year.

Table 1. Recommended Running Clearances.

Case Ring Diameter	Metal Rings		Metal Filled Graphite
	API Standard	API Hot	
3,500 to 4,999"	.016"	.021"	.007"
5,000 to 5,999"	.017"	.022"	.009"
6,000 to 6,999"	.018"	.023"	.010"
7,000 to 7,999"	.019"	.024"	.011"
8,000 to 8,999"	.020"	.025"	.012"
9,000 to 9,999"	.021"	.026"	.013"
10,000 to 10,999"	.022"	.027"	.014"
11,000 to 11,999"	.023"	.028"	.015"

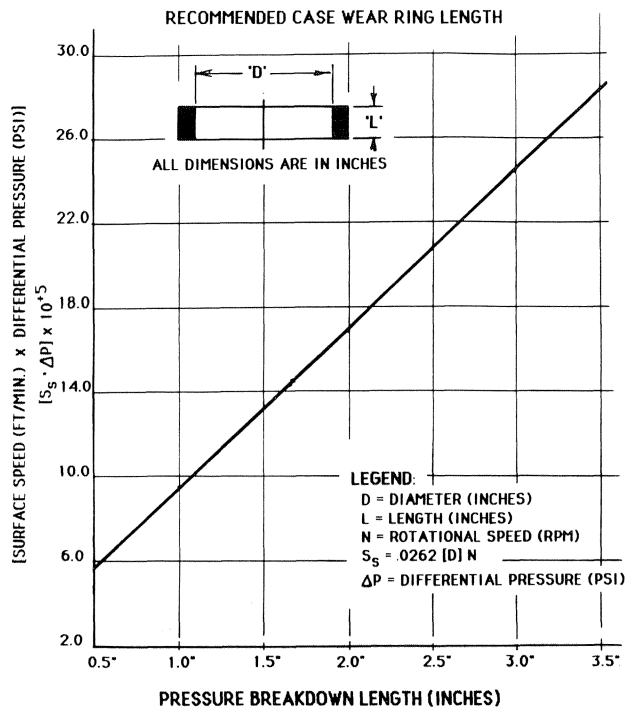

Figure 1. Relationship of Differential Pressure and Peripheral Speed to Case Ring Length.

MATERIAL DESCRIPTION

Metal filled graphite is not a single material, but rather a family of materials, each of which can be varied within wide limits to suit a specific application. Hundreds of grades are produced for a multitude of pump applications, ranging from cryogenic to extreme high temperatures.

The material is made by compounding carbon fillers, binders and additives. These raw materials are converted into a plastic dough in a heated mixer. The dough is cooled, crushed and ground into powder. The powder is then blended with an organic binder and molded into a rough shape. Placed in a controlled time, temperature, and atmosphere oven to convert the organic binders to carbon, and then baked to produce a porous fine-grain graphitized structure. The formed piece is slowly cooled and then rough machined to as close the finished shape as possible. The porous semifinished piece is reheated and impregnated, by a pressure or vacuum process, with molten metal, cooled to room temperature, and machined or ground to

finished size and tolerance. The metal used to impregnate the graphite is selected to be compatible with both the environment and application.

FIELD EXPERIENCE

The following two field conversions illustrate the improvement in the operating life of a problem pump that has been modified by replacing the stationary metal wear parts with metal filled graphite material.

Radial Split Pump (Figure 2)

A single stage, double suction, double bearing, double volute pump, in boiler feed service circulating 925 gpm of condensate at 500°F. with a discharge pressure is 732 psi and a suction pressure of 685 psi. The pump is driven by a 40 hp, 1760 rpm motor. One pump operates while the other is on cold standby. The standby pump could not be heated to operating temperature prior to bringing it on line. In order to prevent galling of the rotating element, due to the distortion of the pump case at start up, it was necessary to increase the diametrical running clearance from 0.020 in to 0.060 in. The chrome case rings and bushings were directly replaced with nickel filled graphite case wear rings and throat bushings with 0.020 in diametrical running clearance. The pumps have operated without incident since the conversion in April 1984.

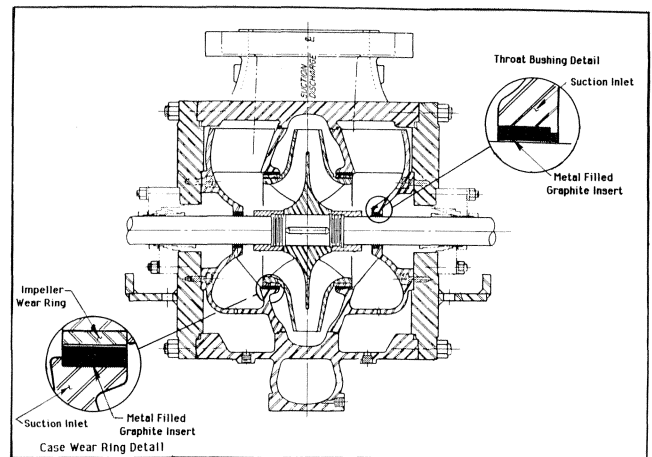

Figure 2. Radial Split Single Stage Horizontal Pump with Metal Filled Graphite Stationary Wear Parts.

Axial Split Pump (Figure 3)

A seven stage, double suction, opposed impeller, double volute in boiler feed service pumping 450 gpm of condensate at 250°F. with a differential head of 2,140 ft. The pump operates at 3560 rpm. the differential pressure across the center stage bushing is 500 psi and across the case wear rings 125 psi.

Three pumps in parallel operation, when two pumps are operating and the third pump was brought online, one pump would cavitate, and the rotating element would seize. Average operating life between seizures was 180 days. Metal filled graphite was added by over boring the existing throttle bushing, center stage bushing and the inner-stage pieces (the suction side case rings remained 400 series chrome). These pumps were retrofitted with Babbitt filled graphite wear parts in 1982, operating life was increased to 900 days. The following is a partial listing (Table 2) of horizontal pump installations fitted with metal filled graphite wear parts.

Table 2. Partial List of Horizontal Pump Installations.

Style	No. Stages	Head	Radial Split		
			Capacity	Operating Temp.	Service
Diffuser	6	2140 ft	450 gpm	+250°F	Boiler Feed
Diffuser	4			+220°F	Boiler Feed
Diffuser	4			+300°F	Naphtha
Volute	1	578 ft	3680 gpm	+70° to 180°F	CO ₂ Booster
Volute	1	140 ft	925 gpm	+500°F	Boiler Circ.
Volute	2	350 ft	550 gpm	+100°F	Propane
Volute	2	780 ft	450 gpm	+250°F	Boiler Feed
<i>Overhung</i>					
Volute	1	390 ft	2335 gpm	+450° to 550°F	Therma 'C'
Volute	1	182 ft	1014 gpm	+370° to 425°F	Distillate
Volute	1	307 ft	1270 gpm	+9°F	CO ₂ Recovery Reflux
Volute	2			+103°F	Propane
Volute	2	1290 ft	433 gpm	+100°F	Naphtha
<i>Axially Split</i>					
Volute	7	2140 ft	450 gpm	+250°F	Boiler Feed
Volute	7	3750 ft	1100 gpm	+275°F	Boiler Feed
Volute	9	3000 ft	825 gpm	+240°F	Boiler Feed
Volute	4	1220 ft	800 gpm	+240°F	Boiler Feed
Volute	6	3400 ft	880 gpm	+70°F	Aux. Feedwater
Volute	8	3900 ft	1450 gpm	+60°F	Super Critical Ethylene
Volute	8	3400 ft	1000 gpm	+90°F	Aux. Feedwater
Volute	7	2200 ft	475 gpm	+240°F	Boiler Feed
Volute	14	4600 ft	430 gpm	+320°F	Boiler Feed
Volute	12	4800 ft	705 gpm	+324°F	Boiler Feed
Volute	12	3900 ft	555 gpm	+70° to 180°F	CO ₂ Injection
Diffuser	10	3300 ft	350 gpm	Ambient	Heavy Water

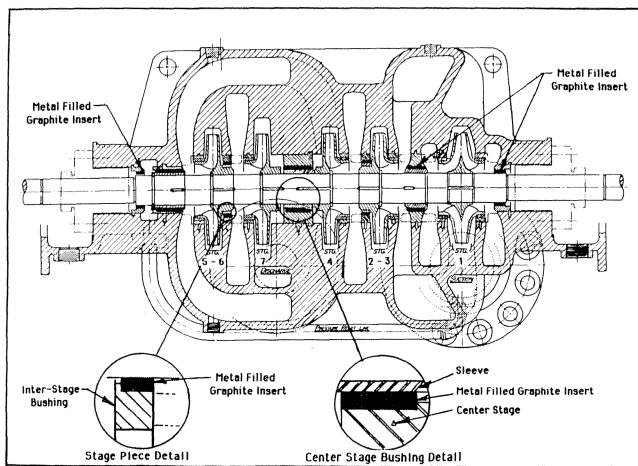

Figure 3. Axial Split Multistage Horizontal Pump with Metal Filled Graphite Stationary Wear Parts.

TEST PROGRAM

After a series of successful metal filled graphite field retrofits which gave individual case specifics and in order to corroborate this field experience, a test program was run, by Sulzer Bingham Pump Company, to record the improvement in reliability and hydraulic performance of a metal filled graphite fitted multistage horizontal pump.

The test program had three objectives:

- Obtain adequate test data to validate any hydraulic efficiency improvements resulting from the closer running clearances possible with a nongalling metal filled graphite fitted pump.
- Verify the capability of a metal fitted graphite fitted pump to survive a dry running mode (loss of suction) and remain operable.
- Verify the capability of a metal filled graphite fitted pump to operate for extended periods at shutoff head conditions (closed discharge head) and remain operable.

TEST PUMP

The test pump was a five stage, horizontally split, single case, opposed impeller, double volute with a single suction first stage impeller. Nickel filled graphite was selected for the stationary wear parts, case rings and bushings, based upon the anticipated test temperatures which might be developed during the dry run and shut-off portions of the test program. Refer to Figure 4 for the nickel filled graphite fitted rotating test element.

TEST RESULTS

Performance Testing

Tests 1 and 2 were identical six point base line performance tests, designed to determine the improvement in hydraulic efficiency.

Test 1 used chrome wear parts with industry standard clearances (Table 3). Test 2 used nickel filled graphite stationary parts and chrome rotating parts with reduced clearance (Table 3).

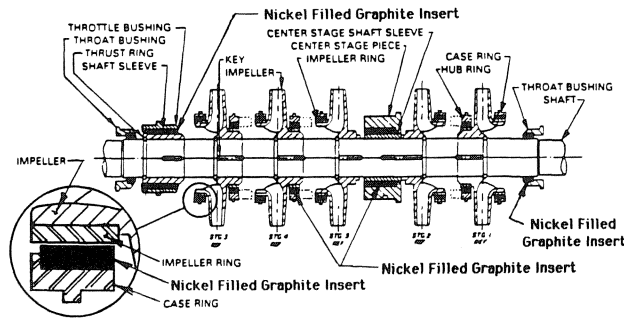

Figure 4. Nickel Filled Graphite Fitted Rotating Element.

Table 3. Test Pump Diametrical Running Clearances.

	Case Wear Ring	Imp. Hub Stg. Piece	Center Stg. Piece	Throttle Bushing
Chrome Fitted	.013"	.011"	.011"	.010"
Nickel Graphite Alloy Fitted	.010"	.008"	.008"	.008"

At the best efficiency point, Test 2 had a 2 percent higher efficiency than did Test 1. Refer to Figure 5 for efficiency comparison curve.

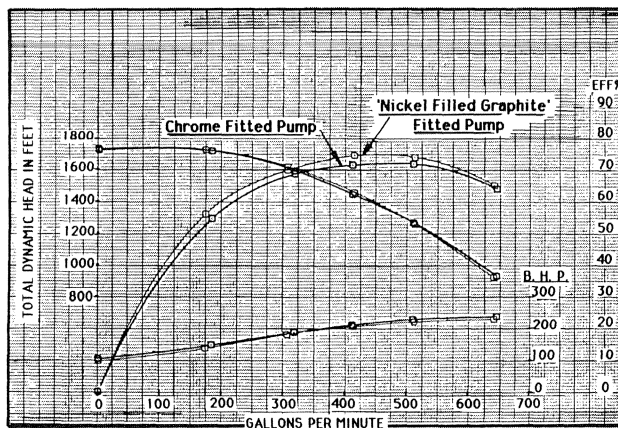

Figure 5. Hydraulic Performance Comparison.

Dry Run Testing (Loss of Suction)

• *Nickel Filled Graphite Fitted Pump (Test 3)*—A data point was taken to verify the pump performance was identical to the base line test (Test 2). The pump was then run dry by closing the suction valve and opening the test loop outflow valve (Figure 6 for Test Loop Schematic). Mechanical seal injection was maintained at a rate of 0.25 gpm. The dry run continued for 22 minutes and was concluded when no visible changes were observed and all temperatures and pressures had stabilized. The suction valve was opened and the test loop refilled.

A six point performance test was immediately run which confirmed the pump performance did not change as a result of the 22 minute dry run.

Post test inspection revealed no rubs, unusual wear or other anomalies.

• *Chrome Fitted Pump (Test 6)*—A data point was taken to verify the pump performance was identical to the base line test

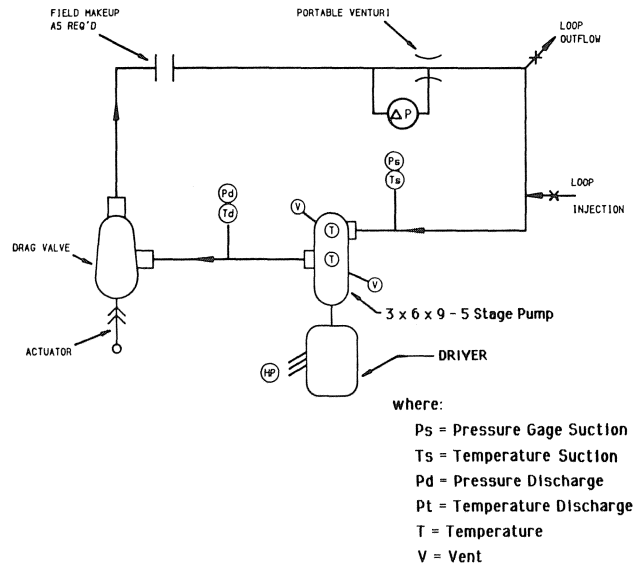

Figure 6. Test Loop Schematic.

(Test 1). The pump was then run dry. The motor wattage dropped from 492 to 25 and remained steady. After two minutes, the wattage suddenly climbed to 500 watts in five seconds and the pump was immediately shut down with the rotating element coming to an abrupt stop.

Post test inspection revealed failure of the first stage suction wear rings with the case and impeller rings welded together. Galling also occurred between the throttle bushing and sleeve. Refer to Figure 7, for a post test comparison of the nickel filled graphite and chrome ring combinations.

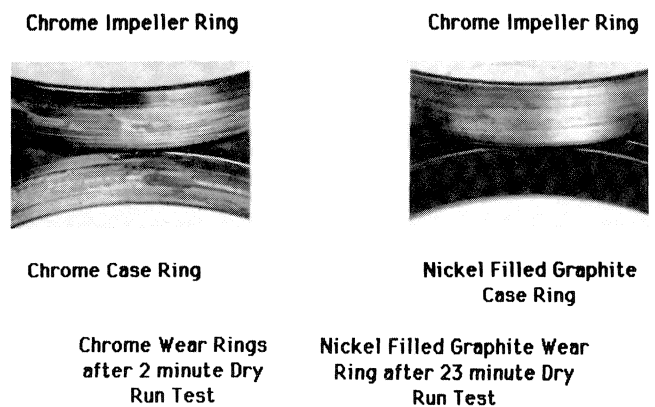

Figure 7. Comparison of Case Wear Rings After Dry Run Test.

Shutoff Head Test (Closed Discharge Valve)

• *Nickel Filled Graphite Fitted Pump (Test 4)*—A data point was taken to verify the pump performance was identical to the base line test (Test 2). The pump was then run at shutoff condition (discharge valve completely closed) for 54 minutes. The pump internal temperature measured at the fifth stage volute, stabilized at 315°F after 45 minutes.

The discharge valve was opened after running for 54 minutes at shutoff, due to increasing seal leakage caused by the elevated pumpage temperature. The opening of the discharge valve resulted in a temperature transient with a cooling ramp rate of 22°F/second, as measured internally at the fifth stage volute.

After the pumpage temperature had stabilized, a performance confirmation test was run. The pump hydraulic performance had not been affected by the extended shutoff test or by the subsequent thermal shock when the discharge valve was opened.

Post test inspection revealed no unusual wear or anomalies.

VIBRATION COMPARISON

Closer running clearances possible with metal graphite alloy case wear rings also provides better damping of the rotating element. A smoother running element will increase the operating life of mechanical seals and the thrust and radial bearings.

The following two examples demonstrate the reduction in vibration amplitude, after the conversion from metal to metal filled graphite case wear rings and bushings.

Multistage Pump (Refer to Figure 4, for Rotating Element)

Vibration data were recorded during the base line performance (Tests 1 and 2, detailed previously). A comparison of the displacement readings is shown in Figure 8. Refer to Table 3 for running clearances.

amplitude, metal filled graphite case wear rings and throttle bushings were installed in the pump in July 1989. The running clearance was reduced to 0.010 in dimetrical. The comparison of vibration velocity amplitudes is shown on Figure 10.

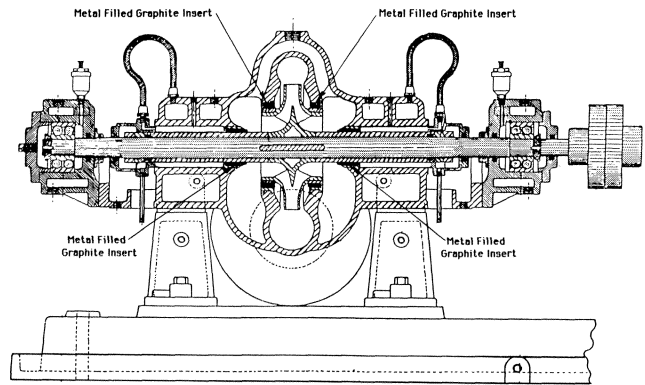

Figure 9. Axial Split Single Stage.

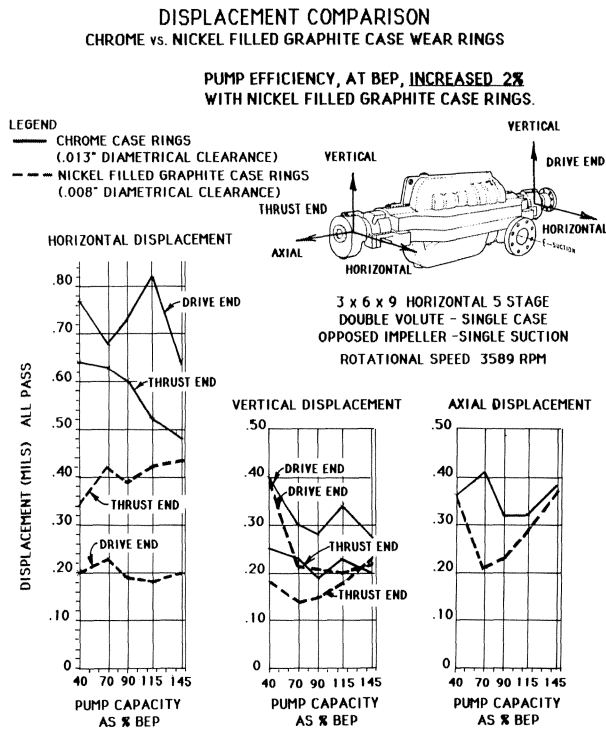

Figure 8. Displacement Comparison.

Single Stage Pump (Figure 9)

A double suction, double bearing pump operating at 3560 rpm, pumping light hydrocarbons at +450°F. Running clearance was 0.029 inches diametrical, which is 0.010 inches greater than the API standard. The pump was originally furnished with packed stuffing boxes. After the stuffing boxes were converted from packing to mechanical seals, the pump vibration measured, in the horizontal plane, at the inboard bearing housing had increased to an unacceptable level. Removing the shaft bearing support, the packing had provided was thought to be the cause of the high vibration levels now measured. After several modifications were tried that failed to reduce the vibration

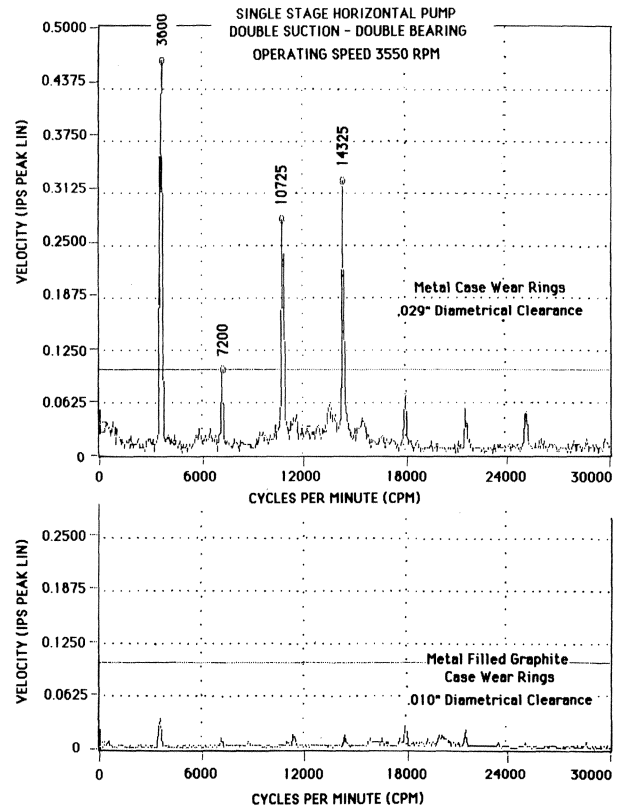

Figure 10. Comparison of Vibration Velocity Metal vs. Metal Filled Graphite Case Wear Rings

Figure 10. Comparison of Vibration Velocity Metal vs Metal Filled Graphite Case Wear Rings.

ENDURANCE

The vibration trend display of the vibration velocity of a two stage, opposed impeller, single suction, high temperature, high pressure process horizontal pump is shown in Figure 11. The readings were recorded in the horizontal plane at the ball bear-

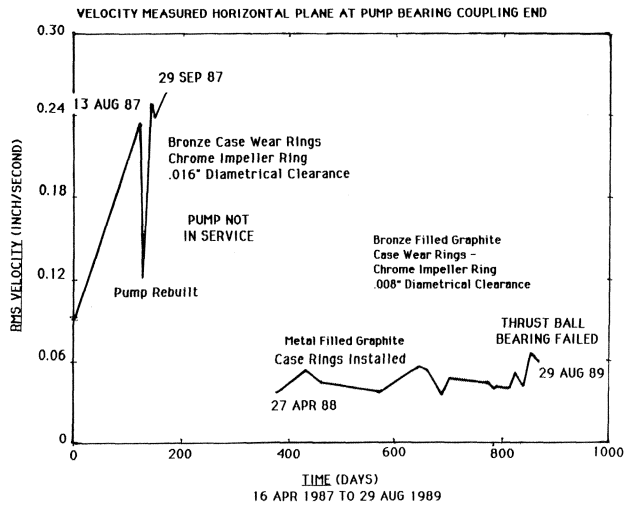

Figure 11. Velocity Trend Display of Overall Value.

ing on the pump coupling end. This curve illustrates that the metal graphite alloy case rings and bushing have retained their

initial clearance over time. Pumpage is water condensate at 275°F. Pump was retro-fitted with metal graphite alloy in April 1988. Metal case rings had a running clearance of 0.016 in diametrical and the metal impregnated alloy have a running clearance of 0.008 in diametrical.

CONCLUSION

The field retrofits and the test program have demonstrated that metal filled graphite can improve pump hydraulic efficiency by allowing closed running clearances. A pump so equipped can survive a loss of suction without seizure, and can run at shutoff for extended periods. The metal filled graphite wear parts will provide better damping of the rotating element thereby reducing vibration and increasing both mechanical seal and thrust bearing service life. Metal filled graphite can be used at temperatures that range from cryogenic to over 700°F.

The limiting factor is abrasive particles in the pumpage. Pumpage that contains more than 50 ppm of abrasive particles may not be a good candidate for metal filled graphite case wear rings and bushings.