



ELECTRIC POWER SUPPLY EXCITING TORSIONAL AND LATERAL VIBRATIONS OF AN INTEGRALLY GEARED TURBOCOMPRESSOR

by

Martin L. Leonhard

Manager, Mechanical Department

Ulrich Kern

Senior Engineer

and

Klaus Reischl

Senior Engineer

Atlas Copco Energas GmbH

Cologne, Germany



Martin L. Leonhard is Manager of the Mechanical Department for Atlas Copco Energas GmbH in Cologne, Germany. He has been with them since 1984, first as Manager of the Development Design for expanders, and then in his present position.

Dr. Leonard received a Dipl.-Ing. degree (Mechanical Engineering) from Karlsruhe University. He did research in high-speed journal bearings at the Mechanical Design Institute and earned his doctoral degree

(Mechanical Engineering) at Karlsruhe University. He is a member of VDI.



Ulrich Kern is a Senior Engineer, working as Group Leader in the Mechanical Department of Atlas Copco Energas GmbH in Cologne, Germany, since 1986. His activities are in the field of torsion analyses as well as structural investigations of highly stressed components of turbomachinery. Previously he spent seven years in the design of steam turbines at Siemens.

Mr. Kern received a Dipl.-Ing. degree (Mechanical Engineering) at RWTH Aachen.



Klaus Reischl is a Senior Engineer, working in the Mechanical Department of Atlas Copco Energas GmbH, in Cologne, Germany, since 1984. He investigates rotordynamic and bearing design. From 1976 to 1984, he was involved in solving vibration problems in rotating and reciprocating machinery at Linde AG, and gained practical experience in a wide range of turbomachinery.

Mr. Reischl received a Dipl.-Ing. degree (Mechanical Engineering) at RWTH Aachen. He is a member of VDI.

ABSTRACT

Commissioning and operating turbomachinery often create surprises especially with respect to vibration. Often not all the conditions are known under which these highly-efficient turbomachines have to operate. This case study deals with a four-stage three-pinion integrally geared centrifugal compressor. It was designed for an air separation plant in Germany to produce nitrogen and oxygen for an adjacent steel works. The compressor was driven via a standard gear-tooth coupling with a 1500 mm (59 inch) spacer shaft by an induction motor with speed of 1490 rpm and power of 4000 kW (5400 hp).

During commissioning, high vibrations were observed at the pinion shafts, which sometimes exceeded the trip levels. The elevated shaft vibration levels occurred for only about 10 minutes. This pattern was repeated once or twice per hour. For the rest of the time, the compressor operated within all the API vibration limits.

Detailed measurements of shaft vibrations, of transient coupling torques (with strain gauges), and of transient electric power are presented as well as calculations of the torsional vibrations of the shaft train using the electric noise of the electric power supply as excitation source. The measure selected to reduce the shaft torques is described by means of which had been possible to reduce the radial shaft vibrations to acceptable levels.

INTRODUCTION

The four-stage three-pinion integrally geared centrifugal air compressor was designed and manufactured in 1998 for an air separation plant in Germany to produce nitrogen and oxygen for an adjacent steel works. The compressor was driven via a standard gear-tooth coupling with a 1500 mm (59 inch) spacer shaft by an induction motor with speed of 1490 rpm and power of 4000 kW (5400 hp). Figure 1 shows the side and top view of the compressor unit with electric motor, coupling, core unit, suction silencer, and filter. Figure 2 illustrates two cross sections of the core unit. The horizontal cross section shows the bull gear shaft and the first three stages. The third pinion with the fourth stage is located on top of the bull gear. The first and second stages are assembled on the first pinion shaft with overhung design. The third and fourth stages are mounted on separate shafts for optimum speeds and best efficiency.

During commissioning in September 1998, high vibrations were observed at the pinion shafts, which sometimes exceeded the trip levels. A very confusing fact was that the shaft vibrations increased only during a certain period of time that lasted about 10 minutes.

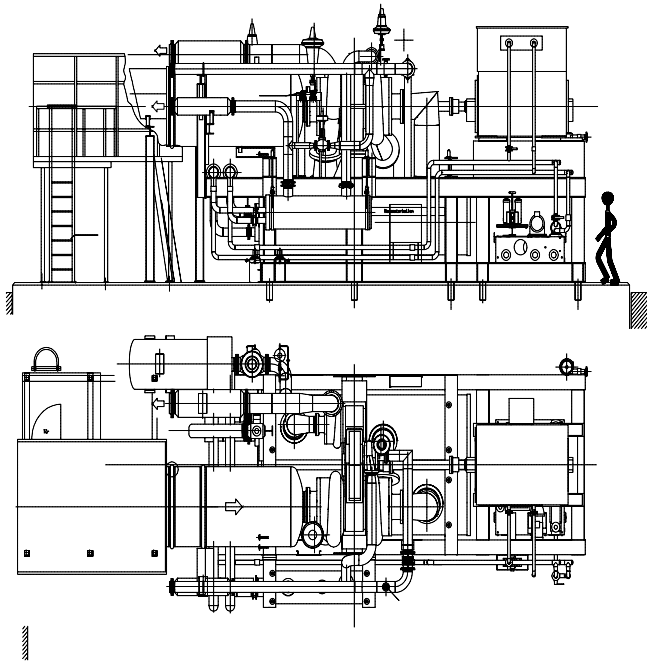

Figure 1. Side and Top View of the Four-Stage Three-Pinion Integrally Geared Turbocompressor with Suction Filter and Silencer.

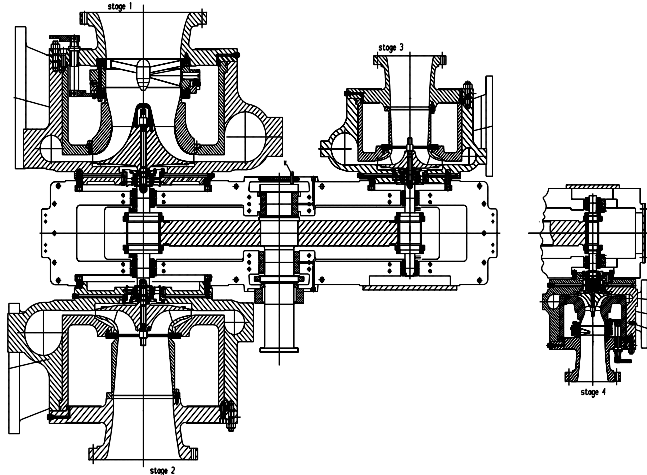

Figure 2. Cross Sections of the Compressor Core Unit, Horizontally Through the First Three Stages and Vertically Through the Fourth Stage (Bull Gear Pitch Line Diameter 1478 mm = 58 In).

This pattern was repeated once or twice per hour. For the rest of the time, the compressor ran within all the API vibration limits.

These types of air compressors are always tailor-made to the specific needs and conditions of the customer. In this case, two gas sections were integrated in one compressor unit to reduce the number of drivers, installation space, and thus investment costs.

STANDARD DESIGN OF TORSIONAL SYSTEM

In order to obtain maximum efficiency during the design phase of the unit, each stage is optimized for size, impeller type, and speed. Based on this, the gear set with gearbox, sealing system, gas coolers, etc. are selected from a standardized modular concept; however, due to the high amount of variation, most of the calculations have to be performed for each unit. This applies especially to the vibration analysis of the lateral and torsional system.

The lateral and torsional vibration systems had been analyzed separately and uncoupled, which is the accepted and relevant method confirmed by experience. The lateral systems of the different rotors were designed to meet all the requirements of API 672 (1996) or 617 (1995) regarding the separation margins and the amplification factors.

The natural frequencies of the torsional system were calculated using a software tool described in Holzapfel, et al. (1998). Typically the lowest order mode is of primary interest, so the most common and convenient varied element is the coupling. The Campbell diagram in Figure 3 shows all the torsional natural frequencies with the possible excitations at $1\times$ and $2\times$ line frequency, the drivetrain speed, and the pinion shaft speeds. As there are four shaft speeds, resonance conditions cannot be totally avoided. These cases will then be evaluated for their sensitivity.

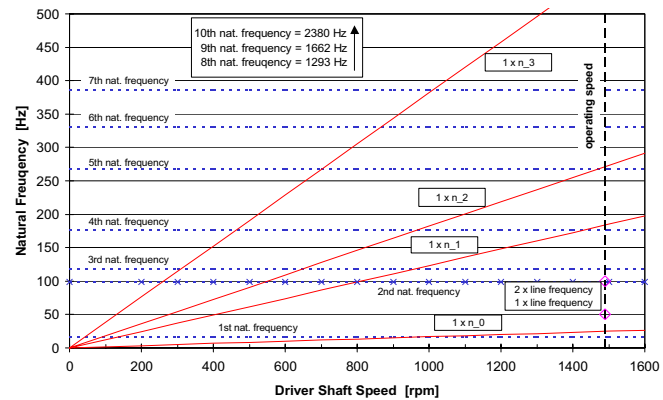

Figure 3. Campbell Diagram of Torsional Shafting System of Compressor Unit Using an Eleven-Lumped-Inertia Parameter Model.

The transient startup of this compressor unit was also analyzed based on the excitation by the air gap torque of the motor rotor. The electric system of the motor was modeled with the resistances and inductances of the stator and rotor and numerically linked to the mechanical system of the compressor (Figure 4). Another software program used (Seinsch, 1999) is a tool for simultaneous calculations of the air gap torque (between the motor stator and the rotor) and the torques in the drivetrain shafting for any transient functions of electric volt-ampere signals. Figure 5 shows the air gap torque and the resulting coupling torque calculated for startup, with the selected tooth coupling equipped with a spacer shaft of 1500 mm (59 inch) length. For the other shaft sections and for the toothing, similar time functions of the transient torques are obtained during startup.

Selecting a higher torsional coupling stiffness or a motor with a much lower mass moment of inertia would increase transient torques to unacceptable levels (Figure 6). For the selected coupling, the calculated transient torques were well within the acceptable range at the analyzed startup conditions.

EXPERIENCES MADE DURING COMMISSIONING

The mechanical shop tests passed all the criteria of the manufacturer and of the applicable standards. But when the compressor unit was started onsite, the commissioning engineer reported high shaft vibrations reaching the trip level and occurring at irregular periods of time (Figure 7). These periods with high vibration levels occurred again once or twice per hour and had a higher impact on the first pinion with the first and second stage than on any other stage.

At this time, the origin of these high shaft vibrations was unknown. Therefore, detailed analyses of the problem were started.

Measurement of Transient Shaft Vibrations

As purchased, the compressor was equipped with only one vibration probe per bearing. To obtain more detailed information,

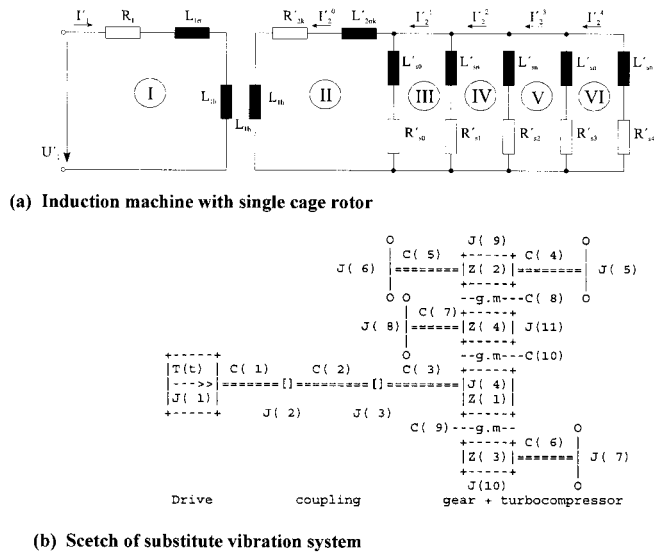

(a) Induction machine with single cage rotor

(b) Sketch of substitute vibration system

Figure 4. Electrical and Mechanical Parameter Models of the Motor-Compressor Unit (Top: Electrical Equivalent Circuit of Single-Cage Induction Motor; Bottom: Torsional System Model of Motor-Compressor Unit with Eleven-Lumped-Inertias).

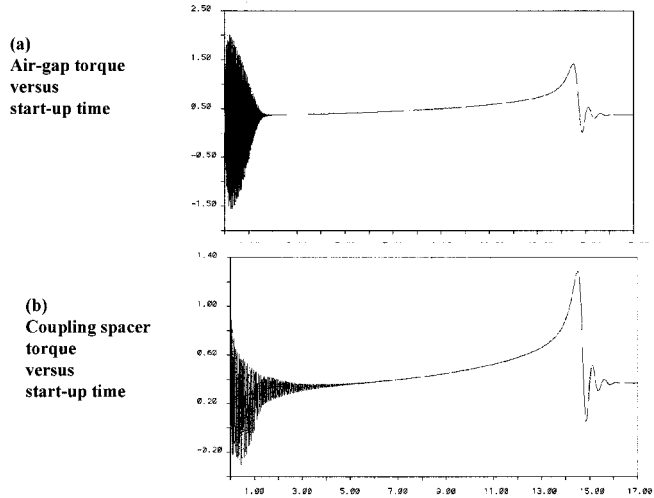

Figure 5. Air Gap Torque (Top) and Coupling Spacer Torque (Bottom) Calculated for Startup of the Compressor Unit with the Induction Motor.

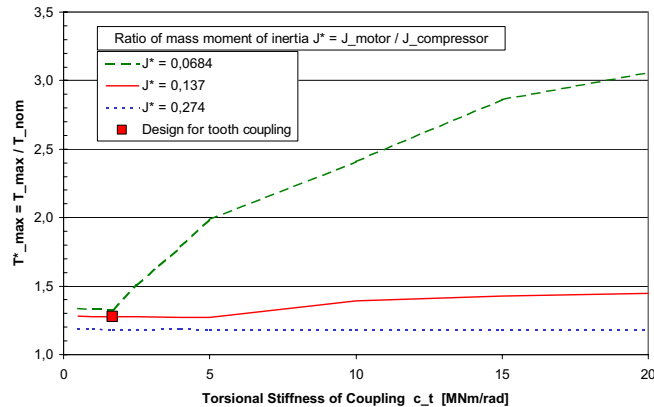

Figure 6. Maximum Transient Coupling Torque Calculated for Startup of Motor-Compressor Unit Dependent on Coupling Stiffness and on Motor-Compressor Inertia Ratio.

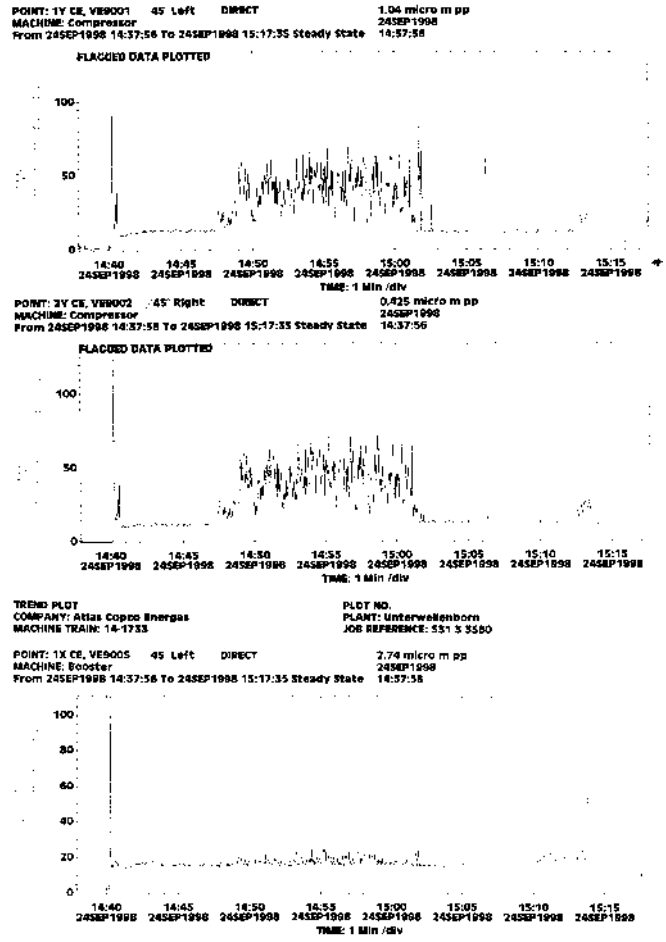

Figure 7. Trend Plots of Shaft Vibrations During Stable and Unstable Periods (Top: at Bearing Stage 1; Mid: at Bearing Stage 2; Bottom: at Bearing Stage 4 (Booster Stage)).

X-Y probes were installed at each bearing and also keyphasor probes at each shaft. Measurements including full spectrum plots were taken during startup, steady-state, and rundown. During the unstable time periods, the first pinion shaft of stages one and two reacted dominantly with a low-frequency vibration of about 17.5 Hz (Figure 8). Additionally, this shaft had speed variations of up to 60 cpm at the nominal speed of 10,952 rpm. The other two pinion shafts were remarkably less affected and their vibrations remained below the alarm levels. A subsynchronous peak could be analyzed with the same frequency but with low level.

Measurement of Transient Electric Power Function (Electric Noise)

In order to get any idea of the operating conditions of the driver, the time functions of the reactive and active volt-amperes of the main grid were measured using the process logic control system of the plant (Figure 9). Surprisingly, the electric power of the motor was fluctuating and not constant. This time function of the volt-ampere signal was also recorded and digitized using special high voltage transformers. The second surprise was that the time periods, where the electric power was fluctuating, correlated with those at which the overall shaft vibrations reached high levels.

VIBRATION ANALYSIS ACTIVITIES

As it was impossible to operate the plant at these conditions, there was a strong sense of urgency to resolve the problem. Several questions arose:

- What was the source of the power supply fluctuations?

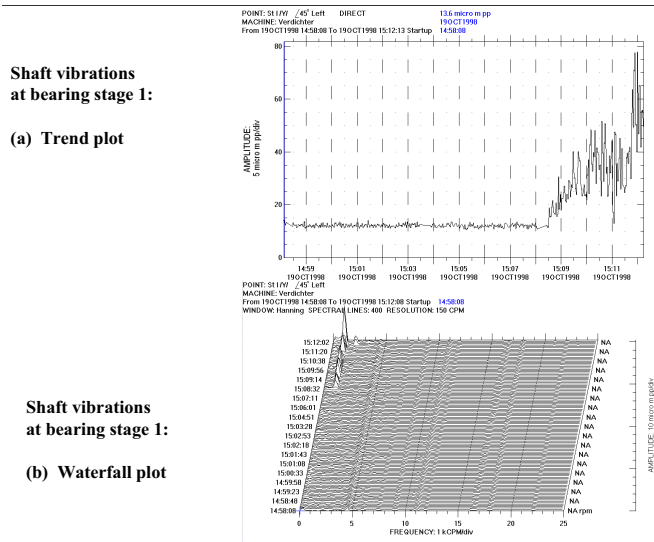

Figure 8. Trend Plot (Top) and Waterfall Plot (Bottom) of Shaft Vibrations at Bearing Stage 1 Measured During Stable and Unstable Periods.

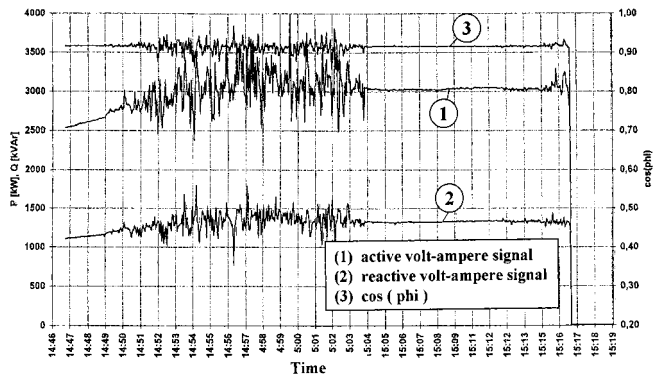

Figure 9. Measured Reactive and Active Volt-Ampere Signals of Main Power Supply.

• Why did the compressor react the way it did and are the compressor train and the compressor shafts designed with sufficient damping?

During the discussions held with the plant designer, the compressor manufacturer was informed that the compressor motor was connected to the same main power line as the electric furnace of the steel works. This furnace was also used to melt scrap iron, which is a very discontinuous process.

The deduced suspicion was that the detected instabilities had been created due to this electric line configuration. A further supposition was that the fluctuations of the main electric power had excited the first torsional natural frequency of the compressor train, and that these torsional vibrations of the bull gear had excited the pinion shafts via the helical gearing in radial and tangential direction.

In order to convince the end user of this supposition, to evaluate the problem, to analyze the transfer mechanism, and to get exact information on the torque prevailing in the coupling, it was decided to carry out both extensive measurements and calculations.

Analysis by Calculations

With the support of the motor manufacturer and the Electrical Engineering Institute IEMA of the University of Hannover, the torsional vibration system of the compressor train was recalculated with the software tool described in Seinsch (1999). As mentioned

above, the measured transient function of the grid voltage and current was recorded and digitized during a short time period of half an hour. Using this information, the air gap torque and the coupling torque were calculated by selecting a special time window of 7.5 seconds (Figure 10). It became obvious that there was a very fluctuating and transient torque response in the coupling spacer, very similar to the one measured. The double amplitude of the coupling torque was equal to 72 percent (peak-to-peak) of the nominal torque.

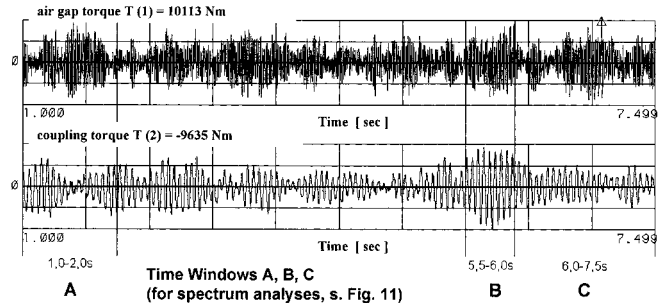

Figure 10. Dynamic Time Function of Air Gap Torque (Top) and Coupling Torque (Bottom) Calculated for the Electric Noise Excitation and for the Three Selected Time Windows.

The dominant frequency of this calculated torsional vibration was between 17.5 and 18 Hz, which was slightly higher than the calculated torsional natural frequency of 16 Hz. In the entire period of time that was analyzed, the frequency spectrum of the measured electrical noise showed only 50 Hz as dominant frequency and a low level broadband under 50 Hz. But when considering only that the time window where the highest coupling torque was recorded (window B in Figure 10), a discrete frequency of about 18 Hz (spectrum of time window B in Figure 11) became obvious in the air gap torque, which is very close to the first torsional natural frequency of 16 Hz. In this condition, the response of coupling torque was maximum (spectrum of time window B in Figure 11).

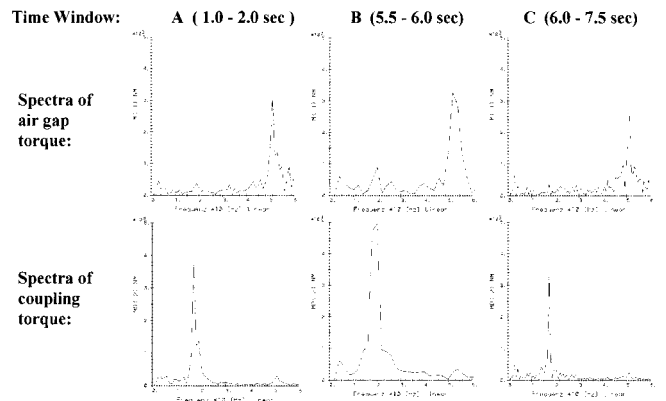

Figure 11. Spectrum Analyses of Air Gap Torque (Top) and Coupling Torque (Bottom) for Three Selected Time Windows Indicating Resonance Conditions Within Window B.

During the other two time periods (time windows A and C in Figure 10), the air gap torque amplitude was even higher, but as the excitation with 18 Hz was lower (refer to spectra in Figure 11), so too the reaction of the coupling torque was lower. The preliminary conclusion was that the electric noise excited the first torsional mode during certain time periods on account of the resonance condition. The reason why the electric noise includes the 18 Hz portion during these periods was still unknown and could not be analyzed in more detail.

Analysis by Measurements

Parallel to these calculations, additional measurements were launched. The coupling spacer was equipped with strain gauges and a telemetry system was installed (Figure 12). This system was used to measure the steady-state and dynamic torque of the coupling during full operation. The dynamic coupling torque was measured with double amplitudes of 55 to 105 percent (peak-to-peak) of nominal torque during unstable periods (Figure 13). The trend plot represented at the top of Figure 14 shows the transition from a stable period without fluctuations to an unstable period, where the torque amplitude started to increase. The waterfall plot shown at the bottom of Figure 14 exhibits that, for the same time period, the dominant frequency of this vibration was at 17.5 Hz.

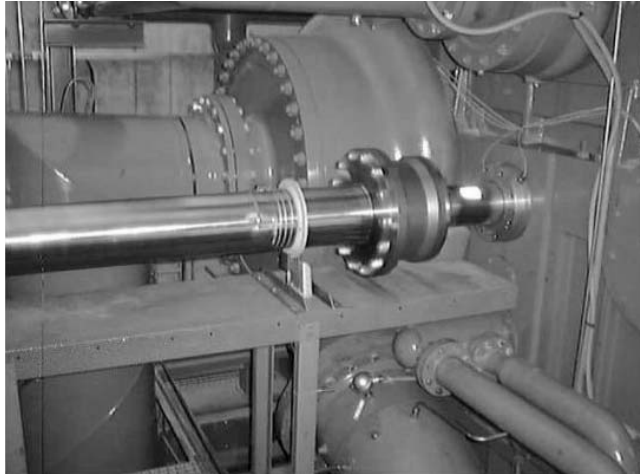

Figure 12. Coupling Spacer with Strain Gauges and Contactless Signal Transfer System (Telemetry System).

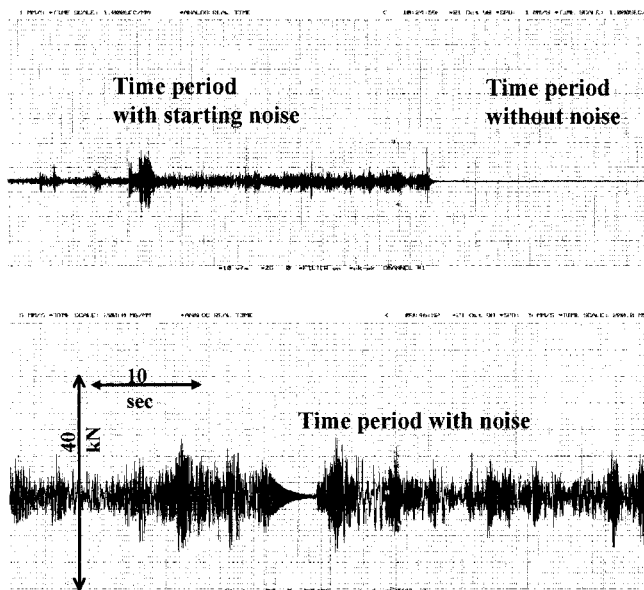

Figure 13. Transient Coupling Torque Measured During Time Periods With and Without Electric Noise Excitations.

SUMMARY OF ANALYSIS AND COUNTERMEASURES

The torque measurements correlated very well with the calculations considering the transient nature of the electric excitation. The calculations proved the supposition that the electric noise of the main power line had excited the motor-compressor train torsionally. The torsional vibrations of the bull gear wheel resulted

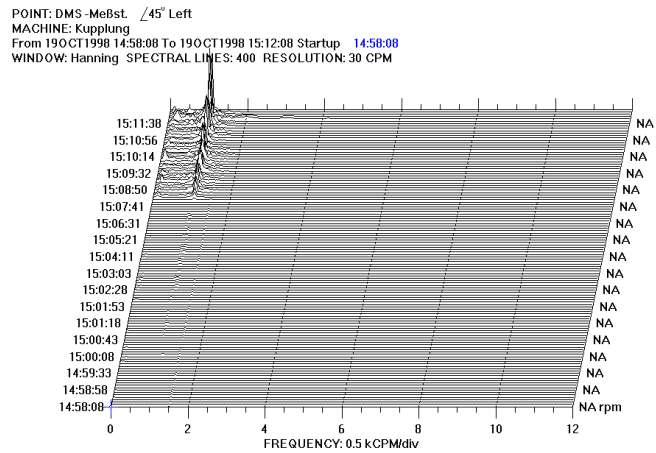
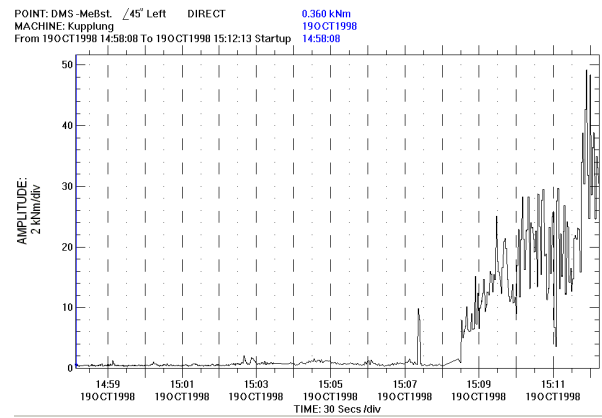

Figure 14. Trend Plot (Top) and Waterfall Plot (Bottom) of Measured Dynamic Coupling Torque with High Subsynchronous Components During Unstable Period.

in fluctuating tooth force between the bull gear and the pinion. These torsional vibrations, in turn, responded by radially exciting the pinion shafts at the same frequency as the torsional vibration. If, for any reason, the exciting frequency of the electric noise coincides with the first torsional natural frequency, the vibrations would have been additionally amplified on account of this resonance condition.

Evaluation of Lateral Vibrations of Pinion Shaft Stage 1-2

This supposition could be confirmed by a rough calculation for the uncoupled shafting system. With the electric excitation, a dynamic torque in the toothing of the pinion stage 1-2 of about 1.1 kNm (peak-to-peak) (9736 in-lbf) was calculated. Applied at the pitch line diameter of the first pinion, this would result in a radial dynamic force of 11 kN (peak-to-peak) (2470 lbf). When this radial force at the frequency of 16 Hz was used as excitation in the lateral analysis, the results revealed shaft vibrations of 22 to 65 μm (peak-to-peak) (0.9 to 2.6 mils) depending on the actual journal bearing stiffness. This calculation correlated well to the shaft vibrations at low frequency measured up to the level of 50 μm (peak-to-peak) (2 mils).

Possible Countermeasures

The service life of the compressor components was rechecked for these high levels of torsional and lateral vibrations. This recalculation showed that there was indeed a real risk for the gearing, the coupling, or the journal bearings.

Generally speaking, two solutions were possible to eliminate the source of the problem:

- Connecting the motor to another electric grid, or
- Installing a special electric filter to dampen the electric noise.

After discussing these options with the client, it turned out that this would require a large amount of capital investment and a long implementation time. Therefore, other countermeasures were discussed to reduce the torsional and lateral vibrations in the compressor to acceptable levels for an unlimited service life:

- Modify the electric motor, or
- Modify the compressor core unit.

Both manufacturers did not see any effective and successful measures to redesign these machine parts. Therefore, the only remaining option was to redesign the coupling—the torque transfer link between the motor and the compressor. The task was to:

- Modify the coupling.

Evaluation of the Proposed Modification

The original coupling was a tooth coupling with a spacer shaft that had a total torsional stiffness of 1.7 MNm/rad (15E+06 lb-in/rad) and an assumed relative damping of only one percent. Variations of the torsional stiffness and damping of the coupling showed that the transient torques of the compressor could be minimized. Figure 15 illustrates the resulting dynamic coupling torques that were calculated for the measured electric excitation. The dynamic torque ratios were reduced for increased damping and for reduced stiffness.

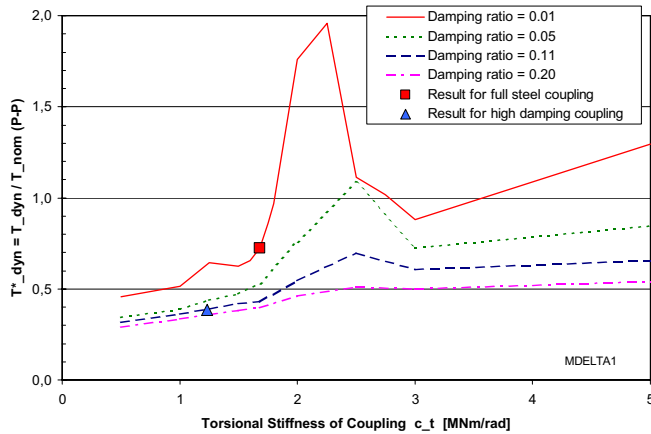

Figure 15. Dynamic Coupling Torque Calculated for the Electric Noise Excitation Depending on the Torsional Stiffness and Damping of the Coupling.

The parameter variations represented in Figure 15 also showed that—if the compressor manufacturer had selected a coupling with a torsional stiffness of close to 2 MNm/rad (17.7E+06 lb-in/rad), the amplification could have reached much higher levels up to twice the rated torque, which might have caused short term damage to the coupling or the gear toothing.

There are few commercially available coupling types with a relatively high damping capacity. These high-damping couplings are normally used for diesel engines and reciprocating compressors where the dynamic torque loading is high during the normal operation. For turbocompressors driven by a synchronous motor, similar coupling types are sometimes used to damp the transient startup torques.

The rubber blocks of the high-damping coupling have a nonlinear stiffness characteristic (Figure 16). At nominal torque, their linearized torsional stiffness is 2.4 MNm/rad (21E+06 lb-in/rad), which is 2.6 times higher as the stiffness at zero torque. With the rubber blocks and the spacer shaft in series, the total torsional stiffness of the coupling is 1.2 MNm/rad (11E+06 lb-in/rad). Assuming a speed-dependent damping performance, the rubber blocks have a relative damping of about 11 percent. Also, as shown in Figure 15, the dynamic coupling torque will be

reduced to 39 percent (peak-to-peak) of the nominal torque. This means that by using the high-damping coupling instead of the all-steel coupling, the dynamic torque would be reduced by 47 percent.

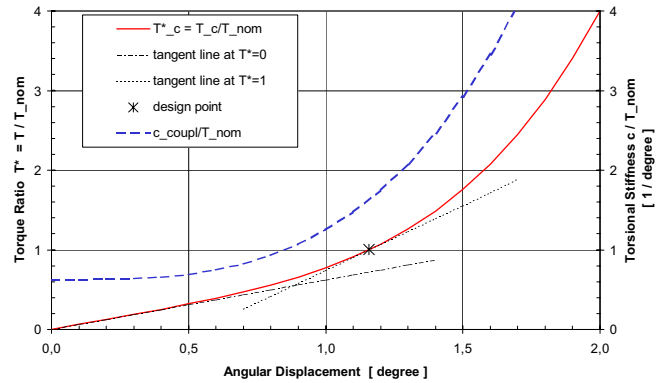

Figure 16. Nonlinear Stiffness Characteristic of the High-Damping Coupling with Rubber Blocks and Linearization at Nominal Torque.

RESULT OF COUNTERMEASURE

After the decision to modify the coupling had been made, it took about two months for the selected high-damping coupling equipped with rubber-blocks to be manufactured and assembled. The motor-end tooth coupling half and also the spacer shaft were replaced (Figure 17). The coupling spacer was again equipped with strain gauges. With the new high-damping coupling, the dynamic coupling torque was measured with double amplitudes up to 78 percent (peak-to-peak) of nominal torque. This is a reduction to 67 percent compared with the levels recorded on the original all-steel coupling. The dominant frequency of this measured vibration changed from 17.5 Hz to 16.5 Hz, whereas 15 Hz had been outlined in the calculation.

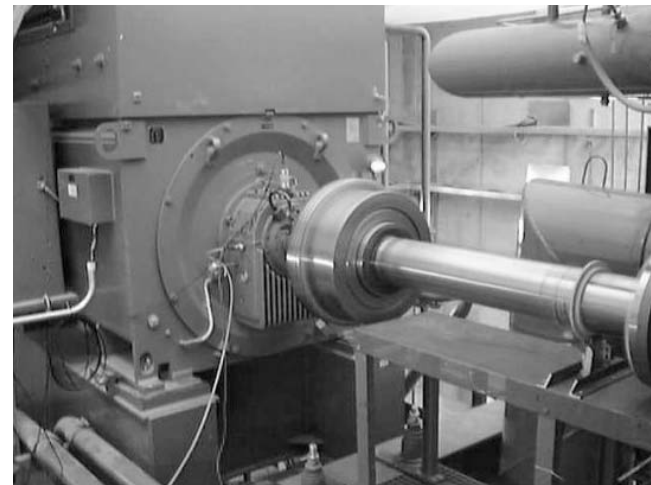

Figure 17. High-Damping Coupling Part at the Motor Side with Spacer Tube Shaft Equipped with Strain Gauge and Signal Transfer Device.

This reduction was less than expected, but the subsynchronous shaft vibrations were reduced to less than 15 μm (peak-to-peak) (0.6 mils) and the overall vibrations remained below 45 μm (peak-to-peak) (1.8 mils) for all conditions, which was less than the original alarm level of 48 μm (peak-to-peak) (1.9 mils).

Since this modification was effected, the compressor unit has been operating satisfactorily for more than two years.

CONCLUSIONS

- High shaft vibrations exceeding the trip levels had been measured on the four-stage three-pinion integrally geared centrifugal air compressor. The reason for this had been the extremely high electric noise generated by the main power line for which the compressor had not been designed.
- Even after all the rules and margins of the standards like API were carefully considered, vibrations occurred for other reasons.
- Electric noise of the main power line has never been used as a design criterion in the past. It seems that this type of excitation will occur more often in so-called highly industrialized areas.
- The software tool that was employed for the presented analyses uses the electric parameters of the motor and simultaneously calculates the electric and the mechanical system. With this tool, it is possible to calculate the air gap torque and the torques in the drivetrain shafting for any transient functions of electric volt-ampere signals, including the normal startup of induction and synchronous motors.
- The damping characteristic of the high-damping coupling was modeled with a speed-dependent function. By using a more sophisticated rheological model, the damping behavior could be described more precisely. Currently the coupling manufacturers do not have these data for their coupling design and the rubber blocks.

- If the impact of the electric noise of the main power line had been known from the beginning, it would have been possible to design the compressor unit adequately for this excitation and to avoid shutdown of the plant.

REFERENCES

- API Standard 617, 1995, "Centrifugal Compressors for Petroleum, Chemical, and Gas Service Industries," Sixth Edition, American Petroleum Institute, Washington, D.C.
- API Standard 672, 1996, "Packaged, Integrally Geared Centrifugal Air Compressors for Petroleum, Chemical, and Gas Industry Services," Third Edition, American Petroleum Institute, Washington, D.C.
- Holzappel, M., Leibbrandt, M., and Bühren, M. 1998, "Simulation Program DRESP for Calculating the Loading of Drive-Train Shaftings," in German, Research Paper No. 485, Forschungsvereinigung Antriebstechnik, Frankfurt/M.
- Seinsch, H. O. 1999, "Computer Program DYN for Calculation of Transient Actions with Induction Motors," in German, Programm Dokumentation des Instituts für Elektrische Maschinen und Antriebe, Universität Hannover.

