

COMPRESSOR SEALS FOR HYDROGEN RECYCLE SERVICE



by

Stephen L. Ross

Senior Service Engineer

M. Theodore Gresh

Senior Consulting Engineer

Elliott Turbomachinery Company Inc.

Jeannette, Pennsylvania

and

Robert M. Kranz

Senior Engineering Specialist

Phillips Petroleum Company

Belle Chase, Louisiana



Stephen L. Ross is a Senior Engineer in the Technical Services group of Elliott Company, in Jeannette, Pennsylvania. He has 22 years of experience with centrifugal compressors, and has been with Elliott Company for 16 years, working in compressor design and field service. He is a previous author for the Twentieth Turbomachinery Symposium.

Mr. Ross obtained a B.S. degree (Mechanical Engineering, 1980) from The Pennsylvania State University. He is a registered Professional Engineer in the State of Pennsylvania and a member of ASME.



M. Theodore (Ted) Gresh is a Senior Consulting Engineer with Elliott Company, in Jeannette, Pennsylvania. He has worked at Elliott Company for 27 years and currently works in the compressor service department. He has been involved with compressor mechanical and aerodynamic design, and as a service engineer, traveled to field installations to investigate warranty claims, conduct field performance tests, troubleshoot user problems, and conduct

training seminars. Mr. Gresh has published various magazine articles and papers on compressor field performance testing and a book, Compressor Performance. He has two patents relating to compressor technology, one of which involves oil lubricated seals.

Mr. Gresh has a B.S. degree (Aerospace Engineering, 1971) from the University of Pittsburgh, is a registered Professional Engineer in the State of Pennsylvania, and a member of ASME.



Robert M. Kranz is a Rotating Equipment Engineer for Phillips 66 Alliance Refinery, in Belle Chase, Louisiana. His primary duties are to develop and execute improvements to the refinery's rotating equipment. He has been with the refinery for 15 years. During that time, some of his other duties included project engineering, inspection, and maintenance supervision.

Mr. Kranz obtained his B.S. degree (Mechanical Engineering, 1986) from the University of New Orleans. He is a registered Professional Engineer in the State of Louisiana.

ABSTRACT

Hydrogen recycle service has presented a special challenge for centrifugal compressors and particularly the casing seals. Typical problems include the presence of liquids (condensables and water), hydrogen sulfide, chlorides, and various amines. Few of these are reported on data sheets during the order entry period, and thus may not be properly considered by the compressor or seal manufacturer application and design team.

A simplified process is reviewed to identify the sources of contaminants. Dry and wet seals are described, and how the various contaminants can affect them. Precautions are listed for the application of dry seals in this service.

Improvements to materials used for a wet seal design are discussed. Two case histories are presented where retrofits with the improved liquid film seal have significantly reduced sour seal oil leakage rates. Increased time between seal changeouts is predicted. Several design improvements over the original liquid film seal are discussed for the second case history.

INTRODUCTION

Hydrogen recycle compressors are used in a variety of refinery processes including catalytic reforming (platforming), hydrocracking, and hydrotreating. While these different processes have unique operating pressures, temperatures, and catalysts, many basic elements are common to them all. Since hydrotreating to remove sulfur is currently an important topic in refining, a simplified process schematic of this process is shown in Figure 1 as an example.

A liquid feedstock is sent to a heater by a charge pump. The liquid is heated by a combination of heat exchangers and a fired heater, but no exchangers are shown to simplify the diagram. The heated charge is combined with hydrogen rich recycle gas and fed to a reactor. Within the reactor, in the presence of a catalyst, sulfur compounds are decomposed to form a hydrocarbon and hydrogen sulfide (H_2S). Other reactions can take place as well. Oxygen compounds are converted to hydrocarbons and water. Nitrogen compounds are converted into hydrocarbons and ammonia (NH_3). Olefins and other unsaturated hydrocarbons are saturated by the addition of hydrogen, producing stable hydrocarbons. Metallic impurities are absorbed physically onto the catalyst surface. The reactor effluent then is cooled and flows through a series of

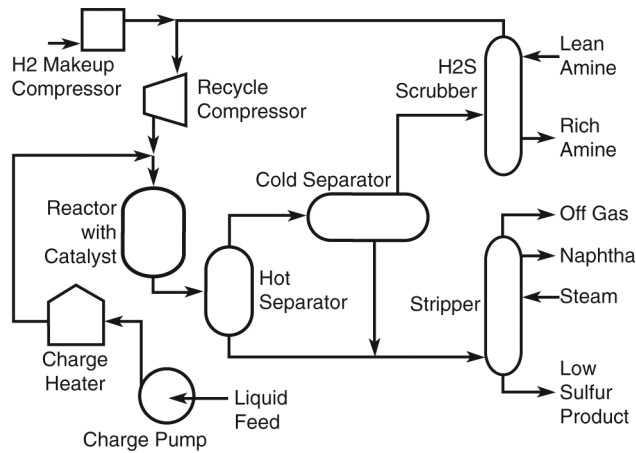

Figure 1. Simplified Hydrodesulfurization Process.

gas/liquid separators. A water wash of the effluent may be included. In this example, a steam stripper removes gas and naphtha leaving the low sulfur product. The gas from the final separator flows to a H₂S scrubber where liquid amines are used to remove H₂S from the recycle gas. Gas from the scrubber enters the inlet of the recycle compressor. Since hydrogen is consumed by the chemical reactions, a makeup compressor supplies additional hydrogen to the loop. This compressor is typically a reciprocating unit.

Seal design for hydrogen recycle compressors has always been a challenge to the compressor original equipment manufacturer (OEM) and a potential source of downtime for the user. Some of the seal design challenges are:

- High pressure, up to 2500 psi.
- Rotordynamic considerations—the low molecular weight of hydrogen recycle gas demands many stages (a long rotor) and high rotational speeds for just a moderate pressure rise. Seals can contribute to vibration problems on an already sensitive rotor.
- Venting of flammable process gas.
- Contamination from process gas.

While all these considerations are important, it is the contamination issue that causes most seal related shutdowns.

TYPES OF SEALS USED IN HYDROGEN RECYCLE SERVICE

Dry Gas Seals

A dry gas seal uses gas, typically the process gas, as a sealing medium. The gas leakage to atmosphere is minimized and controlled by a small, self-regulating gap between a rotating seal ring and a stationary seal ring. A balance of spring forces, hydrostatic forces, and hydrodynamic forces acting on the stationary seal ring controls the width of this gap. The hydrodynamic forces are generated by a pattern of shallow grooves in the sealing surface of the rotating seal ring. A secondary seal, typically an O-ring, is located behind the stationary seal ring to prevent gas from bypassing the gap. Gas pressure is broken down across one or two sets of seal rings and the leakage is vented to the flare system. A second or third set of seal rings serves as a backup in the event of damage to the primary set (Figure 2).

To function properly, dry gas seals require a steady flow of gas that is both clean and dry. This is provided by a buffer gas system that consists of filters, a regulating device, and instrumentation. The amount of gas supplied to the seals is determined by supplying it at a pressure 5 to 15 psi above the pressure to be sealed, or supplying a certain minimum flow. In either case, the excess flow of filtered gas returns to the process across a labyrinth seal inboard of the gas seal cartridge.

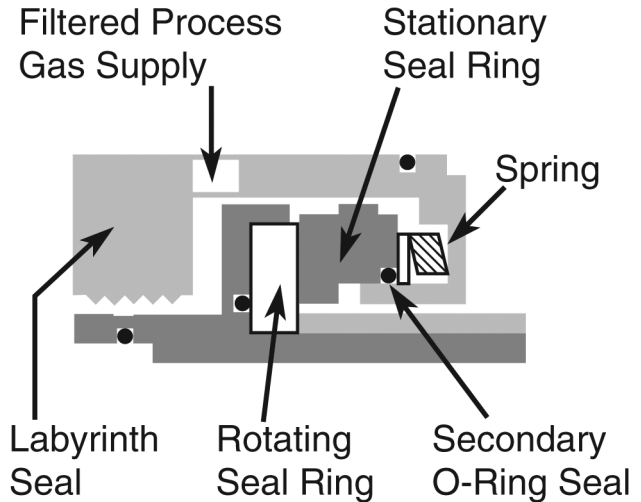

Figure 2. Typical Dry Gas Seal.

Dry gas seals have proven to be very reliable in most services, but have a much higher incidence of failure in high-pressure hydrogen recycle service. In some applications, mean time between failures is as low as three to 18 months. The exact cause of failure is difficult to determine because a damaged seal contaminates itself, ranging from carbon dust to catastrophic break up of rotating rings. External contaminants are almost always present and likely failure scenarios can be theorized. These include:

- Oil and dirt from the process gas filling up the shallow lift grooves in the rotating ring until lift is lost and the rotating and stationary faces contact.
- Oil and dirt from the process gas fouling the secondary O-ring seal so it will not allow the stationary ring to axially track the rotating ring. Eventually, the rotating and stationary faces contact.
- Liquid breaking up the stable gas film between the rotating and stationary faces until they contact.

Any of these scenarios can happen due to inadequate filters, insufficient flow of clean buffer to the seals, or a complete lack of clean buffer during startup/shutdown of the compressor. The contaminants can come from cylinder lubricating oil of the make up gas compressor, chlorides in the process, liquid carryover from upstream vessels, or condensation of the buffer gas. The following precautions should be considered when applying dry gas seals in hydrogen recycle service:

- Prefilters or a mechanical separator to remove larger quantities of liquid upstream of coalescing filters
- Differential pressure control of buffer gas with buffer gas supplied at least 15 psi above the pressure to be sealed. This is to ensure an adequate supply of clean gas to the seal area.
- Use of an air operated booster compressor to supply a flow of filtered buffer gas to the seals at times when the recycle compressor is not running
- Heat tracing of buffer gas supply lines to prevent condensation from occurring

Oil Sleeve Seals

An oil sleeve seal functions on the principal of maintaining a film of oil in a floating bushing at a slightly higher pressure than the process gas that is being sealed. Oil is injected at a very precisely controlled pressure between a gas side seal and breakdown bushing(s). By maintaining an oil pressure of 5 to 10 psi above the gas pressure, the process gas is prevented from leaking to atmosphere. Close clearances minimize the amount of oil that leaks inward to the contaminated oil trap. The volume of oil

flowing through the seal cavity both lubricates and cools the seal. The seal rings are typically lined with a bearing type tin- or lead-based babbitt to avert shaft wear.

H₂S and/or chlorides in the process gas attack the babbitt, and the resulting buildup of corrosion products reduces clearances. The reduced clearance results in localized overheating of the tin-based babbitt and “washing out” of the babbitt. The buildup of corrosion products and lack of babbitt also results in scoring of the shaft sleeves. The end result is increased clearance and extremely high leakage rates for the sweet oil as well as contaminated oil. Oil supply flowrates will increase until either pump capacity is exceeded or pressure losses in the pipes become equal to the design oil to gas differential pressure. In either case, an oil pressure higher than the process gas pressure cannot be maintained and gas escapes to atmosphere. Life of the seals can be as low as six months to a year, depending on the particular situation.

RESOLUTION OF OIL SEAL PROBLEMS

It is obvious that protecting the seal parts with a clean buffer gas, although desirable, is not realistically feasible as the H₂ loop is the highest pressure in the plant. Resolution of the oil seal problem involves upgraded seal parts with an improved babbitt material to resist the chemical attack of the hydrogen sulfide and chlorides in the process gas and hardened shaft sleeves to resist scoring.

A decision was made to use gold for the babbitt material. Gold is chemically resistant to both chlorides and hydrogen sulfide while it has a very soft and malleable nature like tin- or lead-based babbitt. The gold babbitt also has a significantly higher melting temperature, preventing the babbitt from “washing out” during a rub. In general, metals tend to get very soft and putty-like before they reach their melting temperature, like butter that sits out in room temperature for a long period of time. Typically this occurs at about 70 percent of the melting temperature. For tin or lead babbitt, this “soft” region begins around 350°F. For gold, this soft region is estimated to be around 1200°F, as the melting temperature is 1950°F.

An high velocity oxygen fuel (HVOF) spray coating of tungsten carbide with a nickel binder was recommended for the shaft sleeves. The coating is applied to the assembled rotor, and then the sleeve outside diameters are finish ground to maintain size and concentricity with the journal bearing surfaces.

For a retrofit application of upgraded seals, it is strongly suggested to thoroughly clean the entire seal oil system to remove any accumulation of dirt and corrosion products. This cleaning should include the reservoir, any other vessels such as rundown tanks, and all piping. Flushing a clean charge of oil through the system is not sufficient. Cleaning with a chemical agent is preferred.

CASE STUDY A

Background

A small hydrogen recycle compressor operating at an oil refinery in Oklahoma reported having seal problems. Contaminated seal leakage rates were three barrels a day and higher. The time between seal parts changeouts was between six to 12 months. Seal parts that were removed looked overheated and a gritty black substance was found on the surface of all the parts. Both gas side seal and breakdown bushings were found to be wiped and/or scored. The compressor inner barrel was covered with a black oily residue and salt deposits. The journal bearings were found to have some of the same black deposits. Operating conditions are given in Table 1.

Problem Resolution

It was obvious from the seal condition that improved materials were necessary, as clean buffer gas, although desirable, was not realistically feasible. Resolution of the seal problem in July 1998

Table 1. Operating Conditions for Case Study A.

Driver	Steam turbine
Speed (RPM)	12300
Inlet Pressure (PSIA)	1723
Inlet Temperature (°F)	150
Discharge Pressure (PSIA)	2185
Discharge Temperature (°F)	203
Power (HP)	4039
Molecular Weight	5.7
Capacity (ICFM)	1625

involved a thorough chemical cleaning of the oil system, including the overhead tank that controlled the seal oil to gas differential. New seal bushing parts with gold babbitt were installed. The inboard labyrinth seal, located between the process and the oil seal assembly, was made from carbon filled polyetheretherketone (PEEK) thermoplastic instead of aluminum. The spare rotor was reworked with tungsten carbide coated shaft sleeves and installed. The seal configuration is similar to Figure 3.

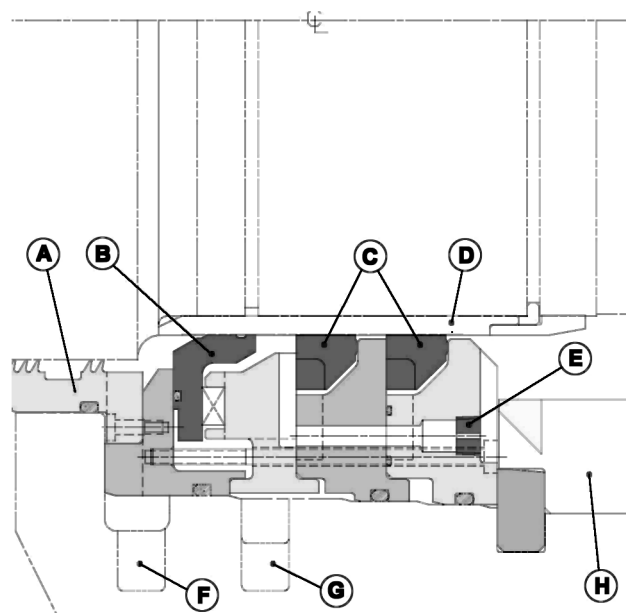

Figure 3. Upgraded Two Bushing Oil Sleeve Seal for Case Study B. (A) PEEK labyrinth seal, B) Gas side seal bushing, C) Atmospheric side bushings, D) Hardened shaft sleeve, E) Oil bypass orifice, F) Contaminated seal oil drain, G) Seal oil supply, H) Sweet oil drain.)

These changes resulted in leakage rates on the order of 1 to 2 gal/day/seal. Four years later the original upgraded seals are still in service. According to the user, leakage rates are still “very low.”

CASE STUDY B

Background

Four hydrogen recycle compressors operating at an oil refinery in Louisiana had been having seal problems for many years. Contaminated seal leakage rates were several barrels a day and higher. The time between seal parts changeouts was 18 to 24 months. Chemical attack of the babbitt had forced a change to cast-iron bushing parts with no lining at all in the bores. Wear and scoring of the shaft sleeves required complete removal of the compressor bundle and replacement with a refurbished spare rotor whenever seal leakage rates became too high. At times, raised

metal of the sleeve required the use of a cold chisel to allow removal of the bushings. The basic seal design dated from the 1970s and was difficult to assemble. Missing or pinched O-rings often led to startup delays. In operation the compressor internals would foul with chlorides and require frequent water washing to maintain performance. Operating conditions are given in Table 2.

Table 2. Operating Conditions for Case Study B.

Compressor String	1 LP	1 HP	2 LP	2 HP
Driver	Steam turbine	Same	Steam turbine	Same
Speed (RPM)	8640	8640	10370	10370
Inlet Pressure (PSIA)	233	439	550	965
Inlet Temperature (°F)	100	100	100	130
Discharge Pressure (PSIA)	449	768	975	1565
Discharge Temperature (°F)	228	217	246	273
Power (HP)	2467	2315	2142	2143
Molecular Weight	7.7	7.0	5.5	5.5
Capacity (ICFM)	2420	1265	817	495

Problem Resolution

A cartridge design seal assembly was suggested by the user and agreed to by the compressor manufacturer. This would allow the seals to be bench assembled and checked prior to installation, thus eliminating concerns about damaged or missing O-rings. All the material upgrades used in Case A were applied (refer to Figures 3 through 6).

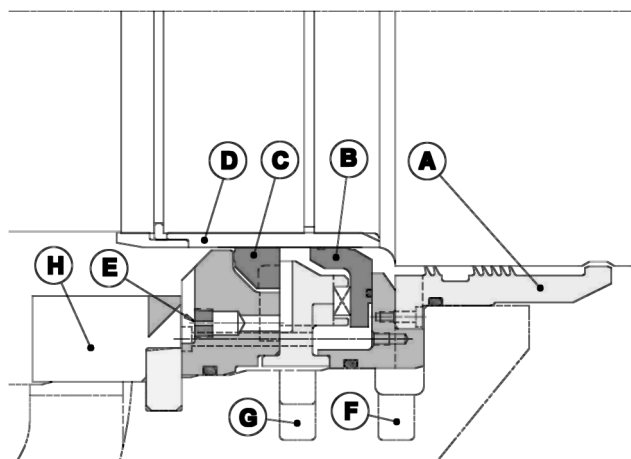

Figure 4. Upgraded Single Bushing Oil Sleeve Seal for Case Study B. (A) PEEK labyrinth seal, B) Gas side seal bushing, C) Atmospheric side bushing, D) Hardened shaft sleeve, E) Oil bypass orifice, F) Contaminated seal oil drain, G) Seal oil supply, H) Sweet oil drain.)

Additionally, tungsten carbide spray coating was applied to the vertical surfaces of the housings where they are contacted by the floating bushings. This coating provides two related benefits. The hardness of the coating minimizes the chance of the bushing brinelling the surface of the housing. This has occasionally happened on high-pressure seals. If the damage is severe, it can prevent the bushing from floating with the shaft and cause it to act like a bearing, creating subsynchronous rotor vibration. The other benefit is the smooth surface finish of the coating will reduce the coefficient of friction between the bushing and the housing; again helping the bushing to float and remain centered on the shaft.

Oil passages were enlarged on the new design to reduce internal pressure drops of the supply oil and to promote better drainage of the contaminated or sour oil. The contaminated drain was a particular concern to the user, as the traps would no longer be vented. The series of eight radial slots in the drain area was replaced by two large bottom slots aligned with the casing drain and two slots in the top that connect to an equalizing line with the overhead seal oil tank (Figure 5).



Figure 5. Inboard View of Upgraded Oil Sleeve Seal Cartridge Showing Thermoplastic Labyrinth Seal (Front) and Contaminated Drain and Vent Slots

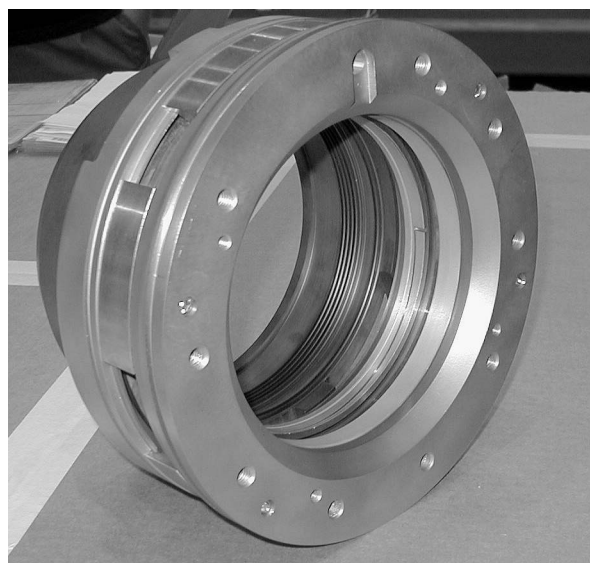

Figure 6. Outboard View of Upgraded Oil Sleeve Seal Cartridge Showing Windback Groove (Bore) and Oil Bypass Passage (Slot at Top).

Another new feature was the addition of an internal seal oil bypass passage. In the past, all the sweet oil flowed across the atmospheric side bushings. The amount of oil required to keep the seals cool was controlled by the clearance between the bushing and the shaft sleeve. The bushing bore was a standard diameter, and the outside diameter of the shaft sleeve was ground to various dimensions to achieve the necessary clearance. For these seals all bushings are the same and all shaft sleeves are ground to the same diameter. If this clearance provides enough flow for cooling, the bypass passage is plugged. If more oil is required, an orifice (minimum 1/16 inch diameter) is fit into the bypass passage. This allows for simple adjustments if process conditions are changed (Figure 6).

During a scheduled turnaround at the end of October 2001, all the affected compressors and turbines from the refinery were sent to two of the manufacturer's service shops. The compressors receiving upgraded seals were disassembled, cleaned, and

inspected. Any worn or damaged parts were replaced. The casings were machined to add larger annuluses in the seal oil feed areas. Any restrictions in internal oil passages were removed by grinding. Vents were drilled into the sweet oil drain cavities, as these were not included in the original design. Other modifications to bearings and couplings were made as well. The spare rotors had been reworked previously and at-speed balanced by the manufacturer. The only problem encountered during installation of the new seal cartridges was difficulty aligning slots on the inboard side of the seal cartridge with existing antirotation pins in the compressor cases. This alignment was done "blind" and was further complicated because some of the pins had been relocated from top-dead-center to new holes 5 degrees to the left or right.

After the compressors were completely assembled, the gas side seals were fed oil at the same differential pressure they would operate at in the field. The leakage rate appeared reasonable. Actual leakage was expected to be better as the bushing would be more concentric to the sleeve, and the windback groove would be effective in reducing oil flow due to shaft rotation. The windback groove feature had been in use since 1984.

Before startup, the oil system was cleaned by circulating heated oil with a high flow pump. In the future, hydroblasting or chemical cleaning would be used.

The first two compressors were started November 16, 2001. The new seals continue to operate with very low leakage. One seal was recently measured at 3.9 gal/day. This is better than expected for seals of this diameter with an oil to gas differential pressure of 8 or 9 psid.

CONCLUSIONS

- Hydrogen recycle gas can contain a number of contaminants harmful to seal operation. Many of these contaminants are not identified to equipment designers.

- Dry gas seals in hydrogen recycle service require more than the standard buffer systems that are acceptable for most other services.
- Oil film seal reliability can be improved by the proper selection of materials suitable for hydrogen recycle gas. Gold babbitt resists corrosive attack by H₂S and has a higher operating temperature limit. Tungsten carbide coated sleeves resist wear and maintain design clearances. Carbon filled PEEK labyrinths resist corrosive elements that can attack aluminum.
- Clean oil systems are necessary for proper seal operation. A simple oil flush is inadequate, chemical cleaning is preferred.
- Cartridge seal design makes for easier assembly.

BIBLIOGRAPHY

- API Standard 617, 1995, "Centrifugal Compressors for Petroleum, Chemical, and Gas Service Industries," Sixth Edition, American Petroleum Institute, Washington, D.C.
- Carter, D. R., 1988, "Application of Dry Seals on a High Pressure Hydrogen Recycle Compressor," *Proceedings of the Seventeenth Turbomachinery Symposium*, Turbomachinery Laboratory, Texas A&M University, College Station, Texas, pp. 3-8.
- Staff Report, 2000, "Refining Processes 2000," *Hydrocarbon Processing*, 79, (11), pp. 85-143.

ACKNOWLEDGEMENT

The authors would like to recognize Elliott Company and Phillips Petroleum Company for permission to publish this paper, Joe Brittain for his contributions to the project for Case Study B, the many individuals at Elliott and Phillips Petroleum who assisted in implementing the project, and Raymond Long for his assistance with the illustrations.

