

RADAR BASED SENSORS—A NEW TECHNOLOGY FOR REAL-TIME, DIRECT TEMPERATURE MONITORING OF CRANK AND CROSSHEAD BEARINGS OF DIESELS AND HAZARDOUS MEDIA RECIPROCATING COMPRESSORS

by

Steinar Fossen

Section Manager, Sensors

Kongsberg Maritime

Trondheim, Norway

and

Ed Gemdjian

Manager, Sensors/Americas

Kongsberg Maritime NJ

Northvale, New Jersey

Appendix Authors:

Larry Cornelius

I/E Technologist

and

J. R. Turney

Mechanical Engineering

Dow Chemical, Texas Operations

Freeport, Texas



Steinar Fossen is Section Manager, Sensors, for Kongsberg Maritime, in Trondheim, Norway. He is currently involved in international sales and marketing. He has a background in startup of technology-based companies, management consulting, strategy and marketing, research work, and was an assistant professor.

Dr. Fossen received his Ph.D. degree (Entrepreneurship/Innovation Management)

from The Norwegian University of Science and Technology.



Ed Gemdjian is Manager, Sensors/Americas, for Kongsberg Maritime NJ, in Northvale, New Jersey. He is currently involved in marine sensors, power and energy applications, engineering, and international sales. He has had seven years in naval and merchant shipping and 24 years in marine and process automation.

Mr. Gemdjian received a B.S. degree (Marine Engineering) from the Institute of

Mechanical & Electrical Engineering.

ABSTRACT

Surveys aiming to isolate the main causes of severe damage of large machines such as reciprocating compressors and diesel engines clearly indicate the need for a reliable method to perform real-time monitoring of the crosshead, crank pin/big end bearing temperatures. The main objective for installing such a system is to reduce the risk of high cost damage and, thus, increase the overall operational level of safety. However, both the hostile environment inside such large machines and the need for a highly flexible system that easily can be installed and adjusted to different

mechanical tolerances have kept existing solutions from being reliable methods of temperature monitoring on these rotating and orbiting bearings.

As an introduction to the main topic of the paper, some selected information on engine damage and causes for such failures—in particular, damage following a detected crosshead and/or crank pin bearing failure situation—have been reviewed. Both indirect and direct methods of bearing temperature measurement are discussed.

The main section of the paper describes the applied technical solution for real-time temperature monitoring. The principle of the applied radar technology is presented followed by installation examples and drawings. These are results from both test and permanent installations (refer to “ACKNOWLEDGEMENTS” at end of paper).

The paper ends with a summary of the major issues discussed and the implications that have been achieved in terms of increased operational safety of large reciprocating machines.

INTRODUCTION

Developments in radar-wireless technology have created an opportunity for new sensor systems that make it easier to provide end-to-end wireless, direct measurement solutions both in maritime and industrial applications. These solutions act as a layer of technology easing the management of process equipment by monitoring and alerting to situations that can be hazardous or costly, such as operating problems of high cost machinery. This represents a situation that should be detected as early as possible, especially for large reciprocating machines, as a serious malfunction is likely to develop very quickly and may even threaten the general safety of the plant. Since serious bearing damage always cause temperature increases, monitoring of bearing temperature represents a valuable indicator in a monitoring system, enabling timely action to protect vital parts of the machine from expensive damage. In this case not only the repair is expensive, but also losses due to nonavailability of the machine escalate the costs. This is observed when a process line has to be stopped due to mechanical problems with a reciprocating compressor, or, when a power

station generator engine is down, a passenger or cargo ship has to be docked for several weeks for repair work.

In far more serious situations, a damaged bearing can result in crankcase explosions—a result of overheating of the moving components inside engines, generating a potentially explosive oil mist. Following several tragic incidents at sea the Maritime Classification Societies and the Safety of Life at Sea (SOLAS) regulations have made it mandatory to install equipment capable of monitoring the bearing temperatures. No diesel powered merchant ship will be allowed to leave port without an approved bearing monitoring and alarm system.

However, for industrial machines, such mandatory regulations do not exist, and decisions related to installation of safety devices such as sensors will depend on the safety policy of the owner/operator of the machines.

FACTS AND OBSERVATIONS

In the marine community, causes for severe bearing seizures are discussed frequently. Such information is also found in statistics on main engine damage published by the Norwegian maritime classification society—Det Norske Veritas (DNV).

Statistics covering the period from 1990 to 1996 (Figure 1) show that main bearing and journal failure are the most frequent (15.7 percent) cause of serious damage in medium speed diesel engines. For this type of engine crank bearing and pin is the second most frequent failure cited. For high-speed engines the comparable percentages are 18.4 percent for main bearing and journal damage and 16.9 percent for crank bearing and pin. The percentage of damage caused by bearing failure problems is lower for slow speed main engines (Figure 2), but still considerable.

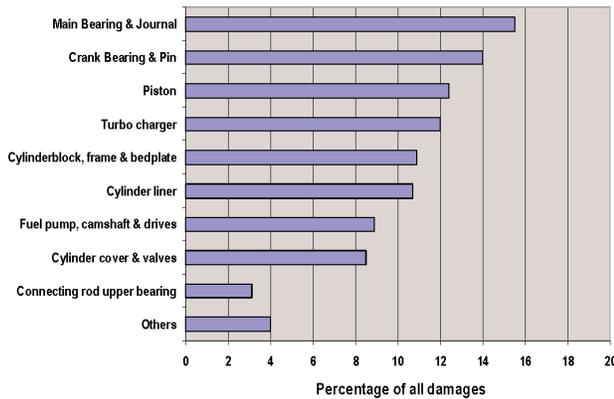

Figure 1. Medium Speed Engine Damages.

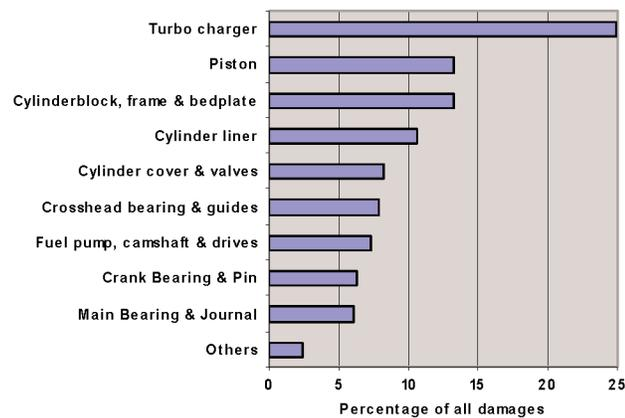

Figure 2. Slow Speed Main Engine.

The causes for bearing failure are well known, identified, and analyzed in detail by many, many sources. Without going deeper into the bearing failures, it is the intent of this paper to focus on the available methods of detecting and preventing such failures.

PRINCIPLES OF BEARING MONITORING ON RECIPROCATING MACHINES

There are two main approaches or principles that can be applied for performing bearing monitoring on reciprocating machines:

- *Indirect monitoring of bearing temperature*
 - Oil mist detection (OMD)
 - Splashed off the bearings oil temperature measurement

The disadvantages of the indirect monitoring methods are obvious. While they could prevent explosions, their response time would not allow prevention of serious bearing failure.

- *Direct monitoring of bearing metal temperatures*
 - Eutectic probes (“turkey poppers”)—This widely known method can be characterized as an “offline” solution that is unable to give any quantitative information of the bearing temperature—only an “abnormal” alarm or shutdown, with no temperature data to support the action or indicate false alarm.
 - Wireless measurement—The new radar-wireless measurement of bearing temperatures by a sensor in direct contact with the bearing shell itself ensures fast, accurate, real-time continuous temperature monitoring. Perhaps as important, it provides at-a-glance visual (digital and/or graphical) indication of a potential failure and “justification” for an emergency slowdown or shutdown.

Monitoring of the real-time bearing temperatures is one of the main advantages of the solution that is presented in this paper—for safe machine operation, as well as research and development (R&D) and machine/bearing studies, based on collected/stored data, which provides a history of the malfunction development, and which is available for analysis and evaluation.

Figure 3 shows the temperature of a bearing when the load on the bearings is increased. The figure shows the difference in temperatures between the indirect splash oil method and the subject radar-wireless direct measurement.

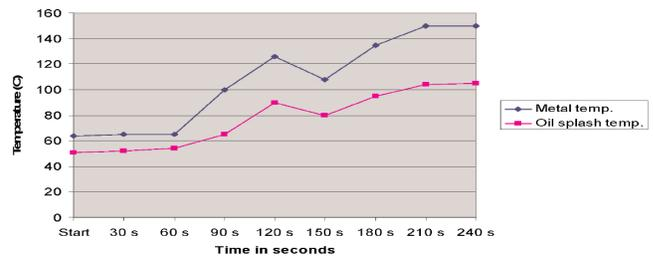

Figure 3. Metal and Splash Oil Temperatures.

REAL-TIME MONITORING OF BEARING METAL TEMPERATURES

From the above findings, it can be concluded that there exists a need for a system designed to perform real-time monitoring of bearing metal temperatures. However, this will demand a solution that can be permanently installed inside the hostile environment of a reciprocating machine. In addition, there is a need to have a passive sensor solution that can be installed and adjusted to different mechanical tolerances. By overcoming these challenges,

a unique radar-wireless system, capable of conducting continuous, real-time temperature monitoring of rotating and moving bearings has been introduced and approved for operation in Class 1, Division 1 (hazardous environments and processes).

APPLIED TECHNICAL SOLUTION

The new solution is based on a specialized radar technology making this completely passive, rugged, industrial sensor possible. The system consists of the following components:

- Signal processing unit (Class 1, Division 1 and 2), power: 24 VDC—intrinsically safe
- Wireless temperature sensor (Class 1, Division 1 and 2), no power applied
- Stationary antenna (Class 1, Division 1 and 2), no power—only low energy radar pulses at 856 MHz

The various system components are shown in Figure 4. As illustrated in Figure 5 the signal-processing unit generates a low energy, high frequency radar pulse, which is transmitted to the wireless sensor via the stationary antenna. When the wireless sensor passes the stationary antenna, the radar pulse is transferred. The wireless sensor, which is a passive reflector (mirror), will immediately reflect the pulse signal, which is received by the signal-processing unit via the stationary antenna. The shape and characteristics of the received signal are then used to uniquely determine the temperature of the sensor. This information is then communicated to a control and monitoring system.



Figure 4. System Components.

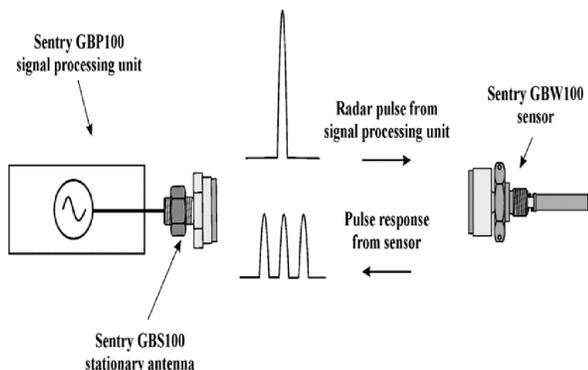

Figure 5. Measurement Principle.

One major advantage of this solution is the high flexibility in arranging sensor and antenna with respect to the gap, angle, and

lateral position between these. Even small changes in positions during operation will not disturb the sensor readings or accuracy.

Further, there is no need for sensor calibration. The radar reflection amplitude has no importance, only the peak-to-peak distances, which are directly related to the law of physical expansion of solids (expansion of the sensing element), which are directly proportional to the sensor temperature. As this is an absolute law of physics, a basic property of each material, there is no degrading of the sensor.

DEVELOPMENT OF THE SYSTEM SOLUTION

The final development of the system solution has been done through a close cooperation with the world’s number one builder of medium speed marine diesel engines. As a part of this technical cooperation a series of functional tests was performed, including a crank bearing seizure. Figure 6 shows the results from the seizure test.



Figure 6. Big End Bearing Seizure Test.

The seizure test was conducted by cutting the supply of lubrication oil. This was done while the engine was running at approximately 1050 rpm. Both the engine speed and the flow of lubrication oil are shown graphically in Figure 6. The red curve is the radar-wireless sensor temperature. The other curves are reference temperatures monitored by a battery-powered thermocouple telemetry method. The main conclusion from the seizure test—the system response time is fast enough to save the crank pin from damage.

In addition to the bearing seizure test, several long-term performance and reliability tests have been performed. In Figure 7 is seen how the crank bearing temperatures will change with different load conditions on a four-stroke medium speed engine.

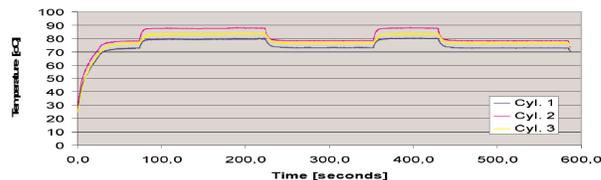

Figure 7. Temperature Versus Engine Load—Diesel Engine.

Figure 8 shows the main and crank bearing temperatures, and, Figure 9, the crosshead temperatures of a large 13,000 hp, four-throw compressor in real time. The compressor was originally delivered in 1982. The sensors were installed by the original equipment manufacturer (OEM) while conducting a major revamp in 2004.

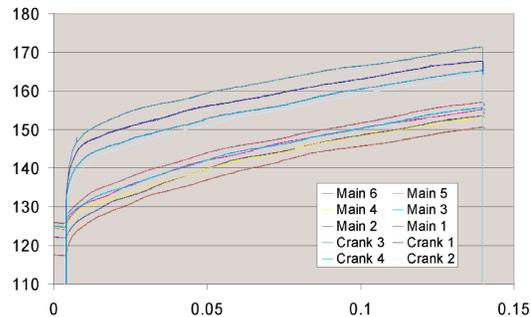

Figure 8. Main and Crank Bearing Temperature of a 13,000 HP Four-Throw Compressor.

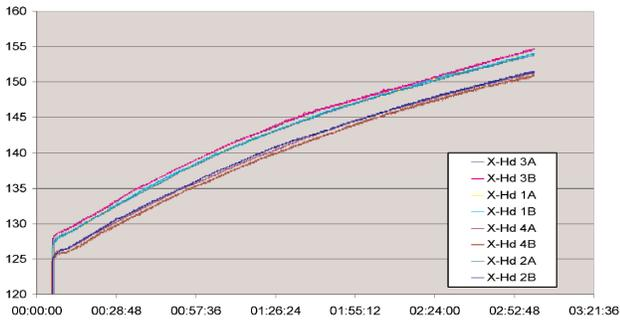

Figure 9. Crosshead Temperatures of a 13,000 HP Four-Throw Compressor.

MECHANICAL DESIGN AND INSTALLATION EXAMPLES

Reciprocating machines vary in size, design, and number of cylinders/bearings. The specific instructions and installation drawings for the sensor-antenna location are typically done in cooperation with the machine manufacturer, obviously for performance and safety reasons.

In the meantime, virtually every major manufacturer of process and gas reciprocating compressors and most large diesel engine makers in the world have installed at least a few of the subject sensors. Many machines already have drilled and tapped mounting holes (or at least drawings for them)—in the connecting rod, crosshead pin, etc. (on older models—as a refit of an old eutectic probe), so there is no need to reinvent the wheel.

Figure 10 shows alternative crank pin installation modes of the wireless sensor. It should be noted that the different manufacturers of large reciprocating machines in many cases have selected different approaches for installing the sensor. There are several reasons for this—a major one being the very uniform temperature distribution over the bearing periphery. Therefore the sensor location is determined mainly by the ease of access and availability of space in each machine, bearing, and frame. Generally, it is not much different from installing a thermocouple or resistance temperature detector (RTD) in the main bearing.

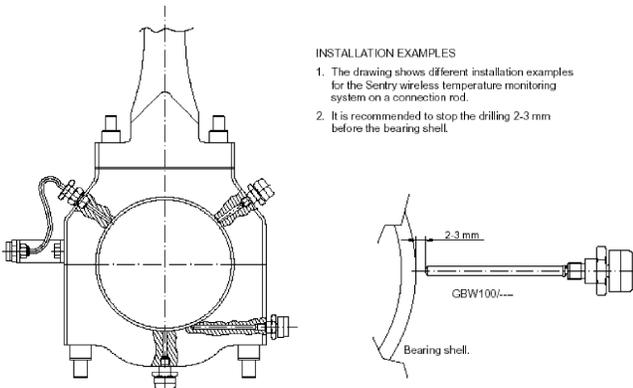

Figure 10. Alternative Crank Pin Sensor Installation Modes.

Figure 11 shows actual installation arrangements in a large process compressor. The drawing shows the sensor placement, the antenna mounting, and the cable gland with built-in coax plug in the casing for connecting the inside and outside coax cable. It should also be noted that in the special case shown in the bottom drawing two crosshead sensors are read by one stationary antenna, but a temperature value for each sensor is measured (discriminated by software).

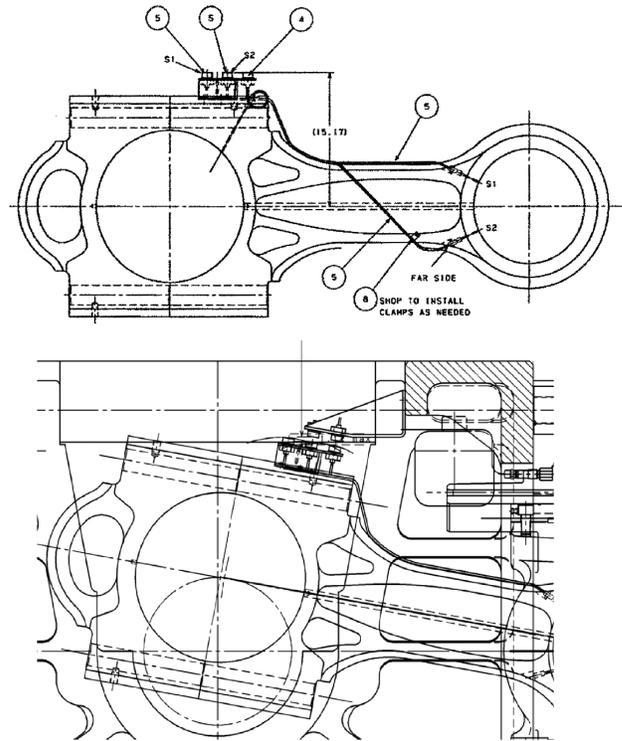

Figure 11. Sensor and Antenna Installation in Compressor (One Crank Bearing and Two Crosshead Sensors).

Figures 12 and 13 are alternative connecting rod drillings and installations (big and small end), done by the manufacturer, their service agent, or a machine shop, based on existing or new drawings.

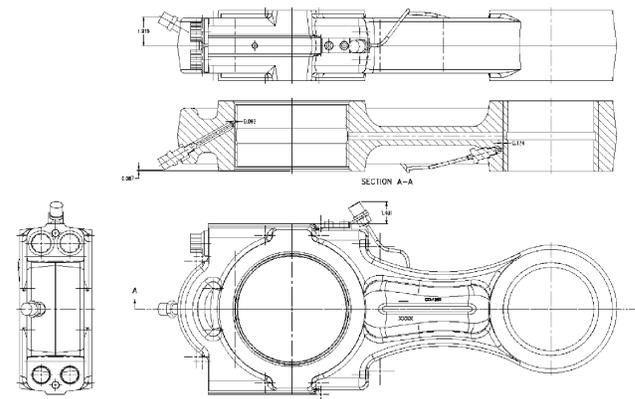

Figure 12. Sensor and Antenna Installation in Gas Compressor (One Crank Bearing and One Crosshead Sensor).

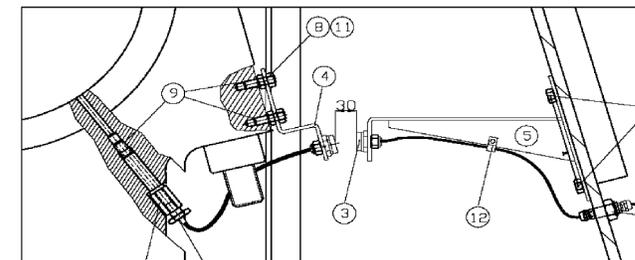

Figure 13. Sensor Installation in Connecting Rod's Big End.

STARTUP AND OPERATION

For the first machine, a factory engineer assisted with the startup. Included in the two-day visit was a two-hour training for the crew covering testing, adjustments (there is practically only one adjustment—the gap tolerance between the sensor-head and the stationary antenna), system components, etc.

The second machine was done without aid of the factory engineer—as you may have guessed, it could not have been too complicated.

There is a small program (of three screen pages) for testing, adjustments, operational parameters, and troubleshooting—all these, in essence from one screen, shown in Figure A-3.



Figure A-3. System Configuration and Troubleshooting Program Screen.

The operation of both machines has been quite satisfactory for more than two years. The temperature readings have been accurate, consistent, and smooth. No false shutdowns so far (since 2004),

just the distributed control systems' (DCS) intermittent sensor failure alarm on one throw, which has not been resolved at this time. The problem sensor/antenna set was removed, wired directly, and they worked fine outside of the machine, which leads the authors to believe that this is a sensor gap or mounting/aiming problem.

APPENDIX CONCLUSION

For the two-plus years of operation the system has been very reliable and an excellent bearing condition and machine safety tool. No spares have been needed yet (except a cable connector).

On the authors' recommendation this system was installed on another compressor at an overseas plant. The authors would strongly recommend it for similar applications. They would probably specify this option were they to buy a new reciprocating machine—a compressor or a diesel engine.

ACKNOWLEDGEMENTS

With sincere thanks and appreciation for the support, engineering, machine/installation drawings, feedback, test and measurement data, etc., the authors thank: with Ariel Corp., Mount Vernon, Ohio—Bob Brannon (Manager R&D), John Konkler (Chief Engineer), Greg Lortie (Engineering Manager Reciprocating Compressors), Matthew R. Mooney (Associate Designer), John Penko (R&D Electronics); with BP Texas City Refinery—Robert Eisenmann (Reciprocating Machine Engineer), Russ M. Hatcher (Process Control Engineer); with Dow Chemical, Freeport, Texas—Larry Cornelius (I/E Technologist), J. R. Turney (Mechanical Engineering); with Dresser-Rand, Painted Post, New York—Martin Hinchliff (Manager Project Engineering), Mike Allen (Project Manager), David Spirawk (Project Engineer), Mark S. Wolfanger (Engineering); with Dresser-Rand, Houston, Texas—Jim Brabham (Account Manager), David Flaim (Account Manager); and with Lyondel-Equistar Chemicals, Victoria, Texas—Ronald J. Moczygomba (Consulting Engineer).