



ASIA TURBOMACHINERY & PUMP SYMPOSIUM
SINGAPORE | 22 - 25 FEBRUARY 2016
M A R I N A B A Y S A N D S



Field Evaluation of an Offshore Pumping System

Jeffrey A. Bennett¹, Augusto Garcia-Hernandez¹,
Marco Antonio Muñoz Prior²
Moisés León Dorantes²,
1 - Southwest Research Institute®
2 - PEMEX Exploración y Producción

Slide 2: Presenter/Author Bios



Jeffrey A. Bennett (Presenter)

- Research Engineer, Southwest Research Institute
- Experienced in thermal fluid network modeling
- MSc – Turbomachinery Aeromechanics, KTH/Université de Liège
- BS – Mechanical Engineering, Virginia Tech

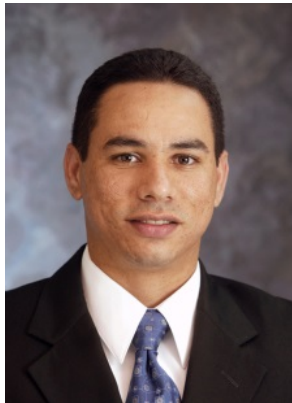

Augusto Garcia-Hernandez

- Group Leader, Pipeline Simulation, Southwest Research Institute
- 12 years experience modeling pipelines and associated machinery
- MS – Petroleum Engineering, University of Tulsa
- BS – Mechanical Engineering, Universidad Central de Venezuela

Slide 3: Presenter/Author Bios

Marco Antonio Muñoz Prior

- Mechanical Engineer Electrician, Design and Optimization of Crude Oil Infrastructure, PEMEX Exploración y Producción
- Mechanical Engineering, Instituto Politecnico Nacional



Moisés León Dorantes

- Former superintendent in the Coordination of Transport and Oil Distribution, PEMEX Exploración y Producción
- Mechanical Engineering, Instituto Politecnico Nacional



Short Abstract

An evaluation was performed on one of the largest offshore facilities belonging to PEMEX Exploration and Production due to forecasts predicting that future crude oil production will contain heavier oils. The primary function of the evaluation was to assist PEMEX in determining if the facility's pumps needed to be upgraded. In addition, several of the centrifugal pumps of the platform had been recently replaced with screw pumps. Therefore, the evaluation was performed in three parts: first, the remaining centrifugal pumps were evaluated in the field at available testing conditions; second, a hydraulic analysis of the network was conducted to predict the system performance with heavier oils; and third, an interactive pump simulator was developed to train operators on the new screw pump equipment. This presentation/paper will focus on the first step, the field evaluation of the centrifugal pumps, and the remaining steps will be discussed briefly.

Presentation Overview

- Field Evaluation
 - System Background
 - Performance Testing Approach
 - Pipeline Modeling Results
 - Field Testing Results
- Hydraulic Modeling
- Simulator Development



Presentation Overview

- **Field Evaluation**
 - System Background
 - Performance Testing Approach
 - Pipeline Modeling Results
 - Field Testing Results
- Hydraulic Modeling
- Simulator Development



Background

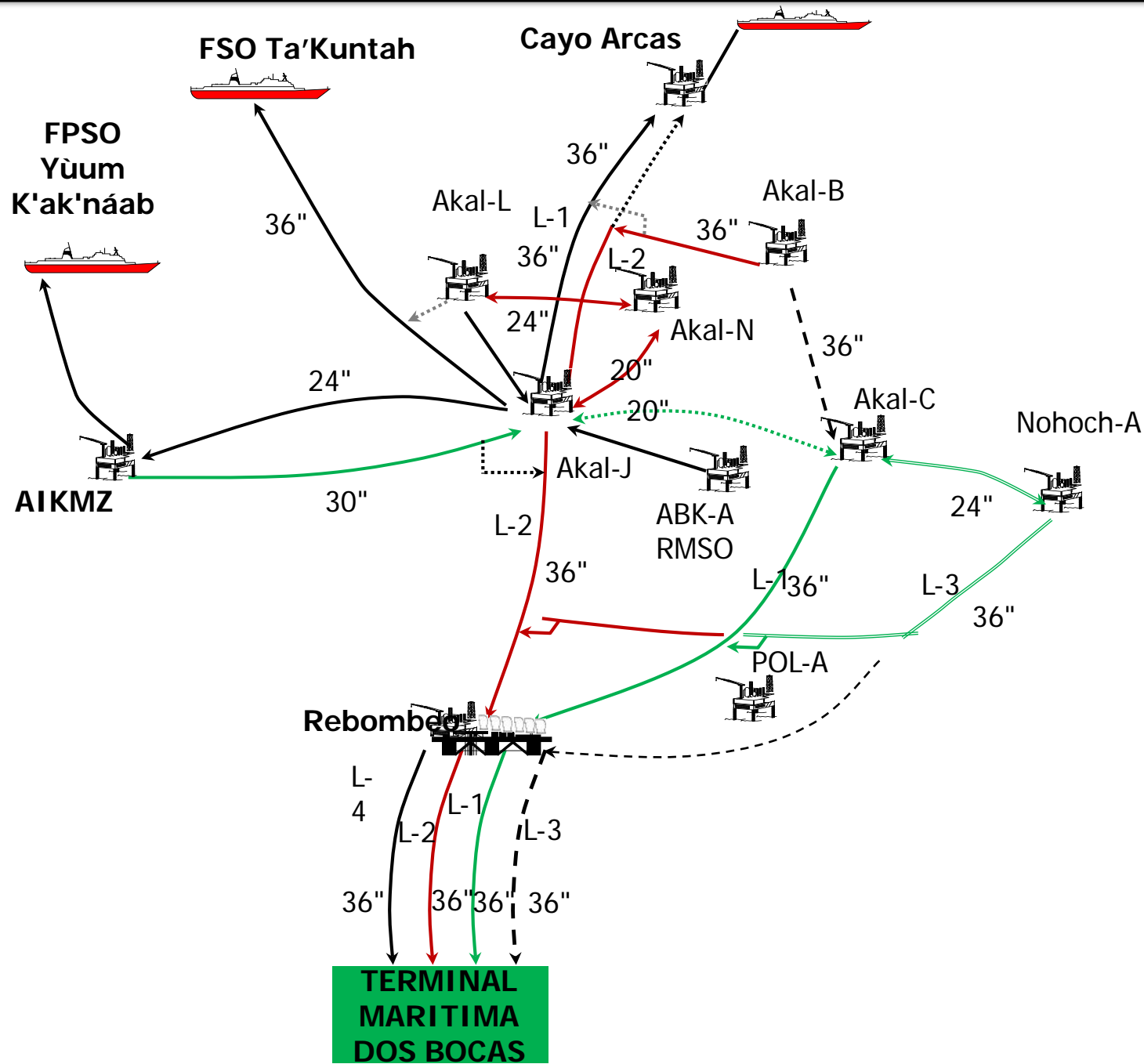

- PEMEX Exploration and Production's off-shore pumping system transports approximately 50% of Mexican crude oil production
- Complex interconnected platform network where different crude oils are mixed
- Historically has operated with 19 API oil, however, forecasts predict mixtures of approximately 16 API oil
- Screw pumps recently installed to help transport heavier oil
- Aging centrifugal pumps require a performance evaluation

Rebombeo Platform

- The booster platform “Rebombeo” is located in the Gulf of Mexico approximately 25 miles off-shore
- Two 36-inch sub-sea pipelines travel 52 miles
- Platform has 10 pumps connected in parallel
 - 6 centrifugal
 - 4 screw (new)

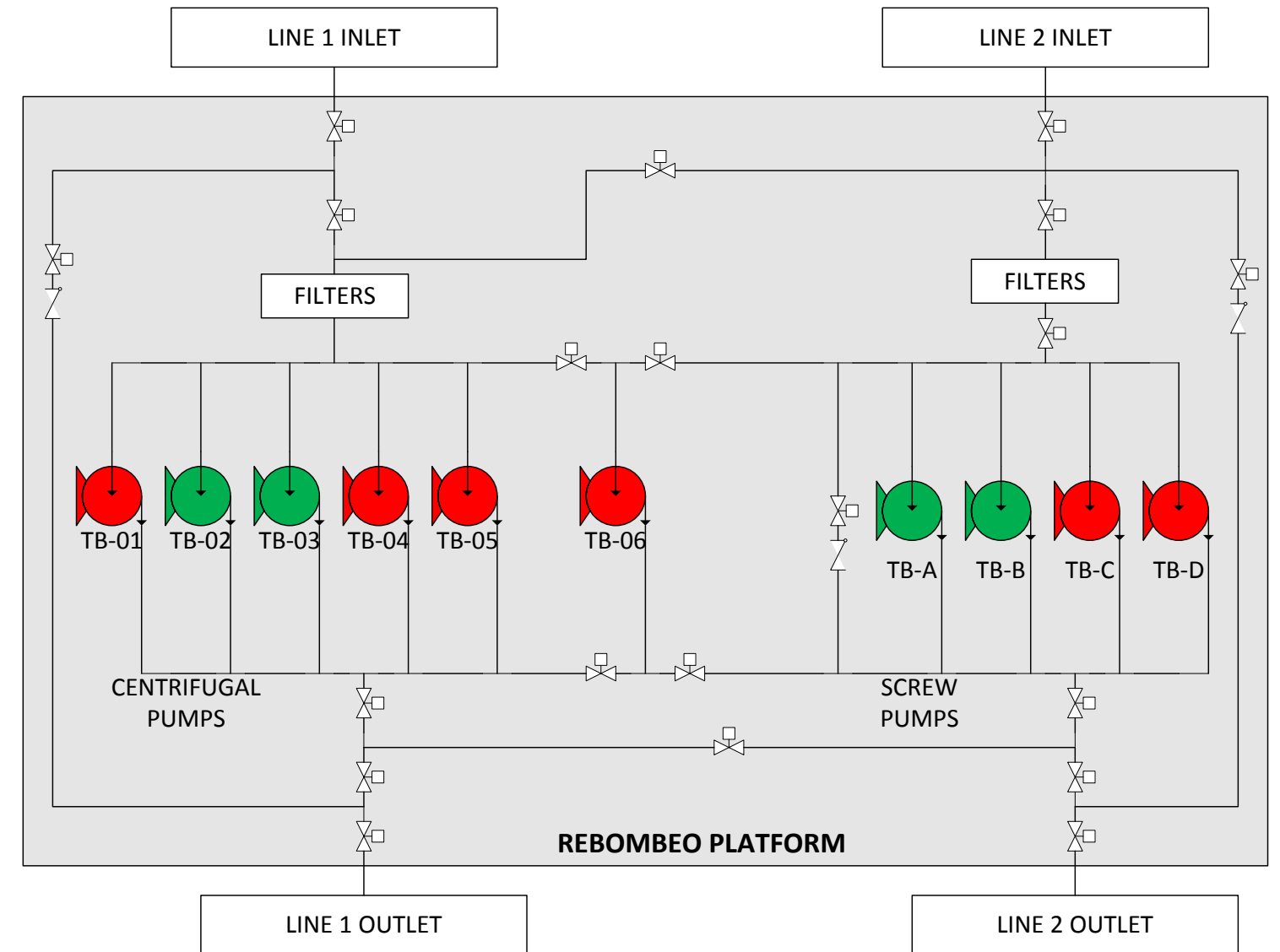

Performance Testing

- Goal: Traverse entire pump curve at a given speed (follow ASME PTC-8.2 Standard)
- This test requires the system pressure difference to decrease as the flow rate increases
- Platform's 6 centrifugal pumps come in 2 varieties – high capacity and low capacity
- Can we take advantage of the different pump types?

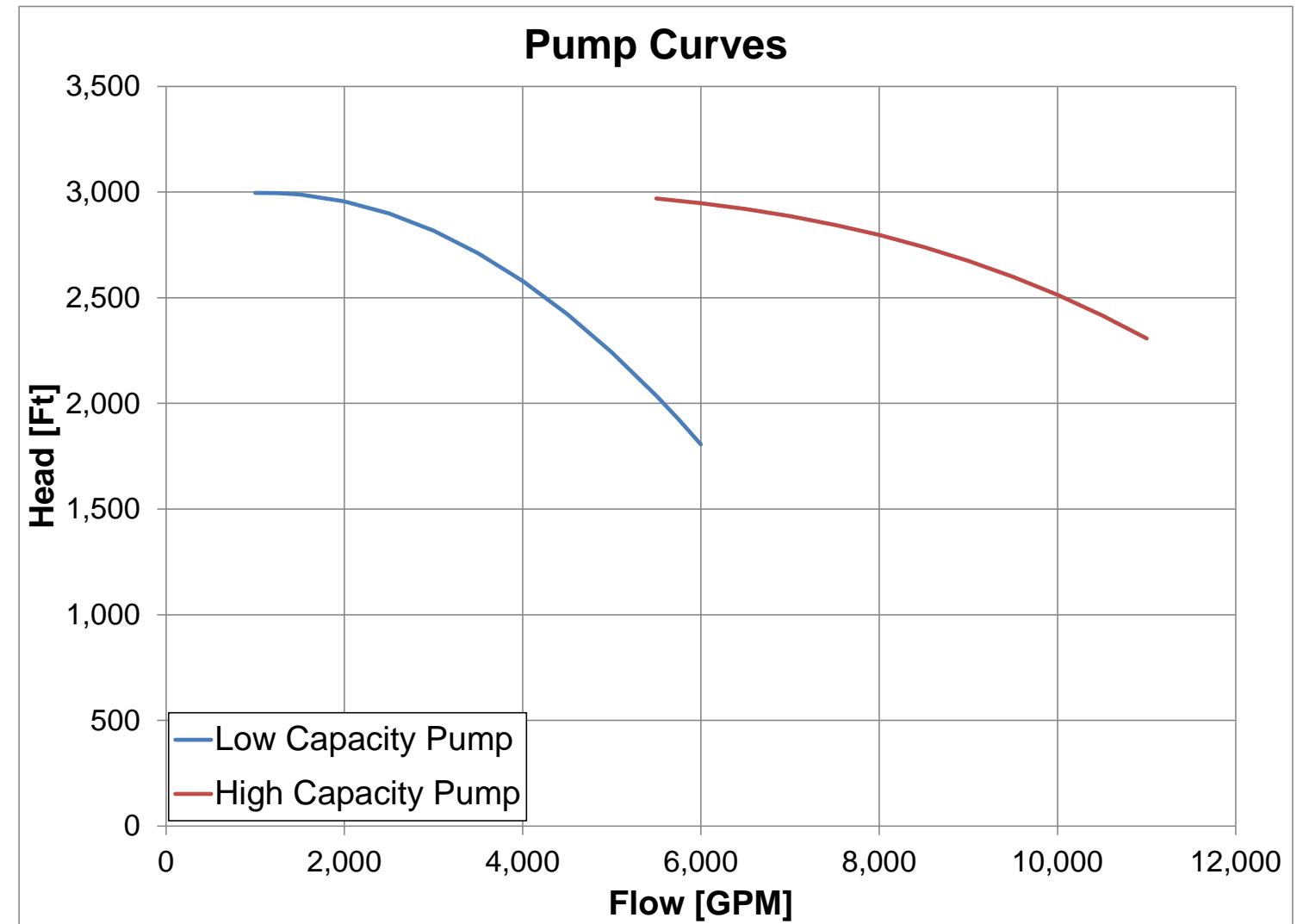

Pipeline System Curves

Pipeline System Curves

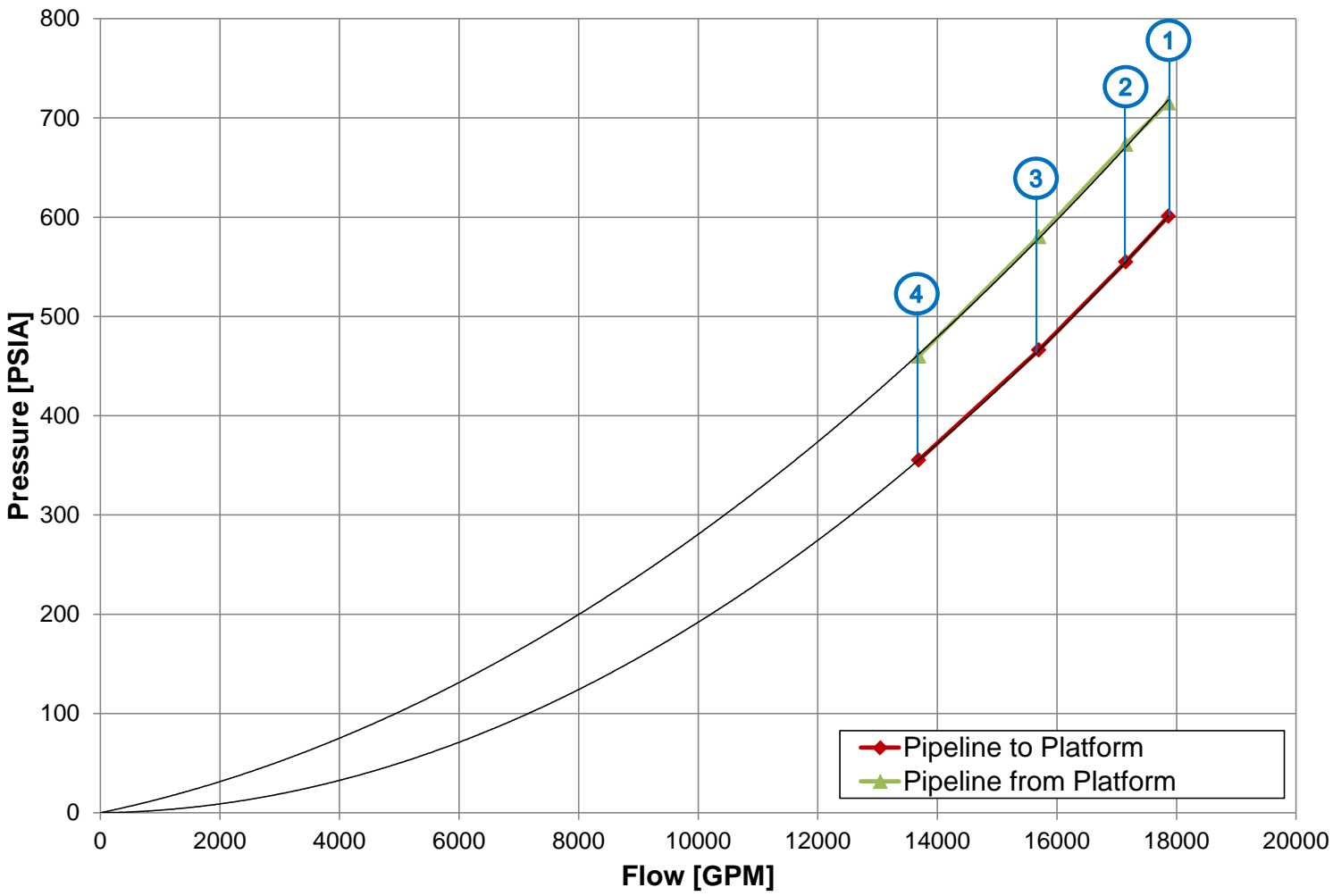

- Dissimilar to the pump curve, the pipeline system curve requires an increasing pressure difference for high flow rates
- For standard operation this is great -> stable operating point
- For testing a means to vary flow conditions is necessary to follow the testing standard

Sample Test Point

- Pumps are in parallel, thus equal head across each
- Test pump kept at constant speed
- Speed of other pumps varied to change flow through test pump
- Pipeline simulations used to prove approach and determine necessary test conditions

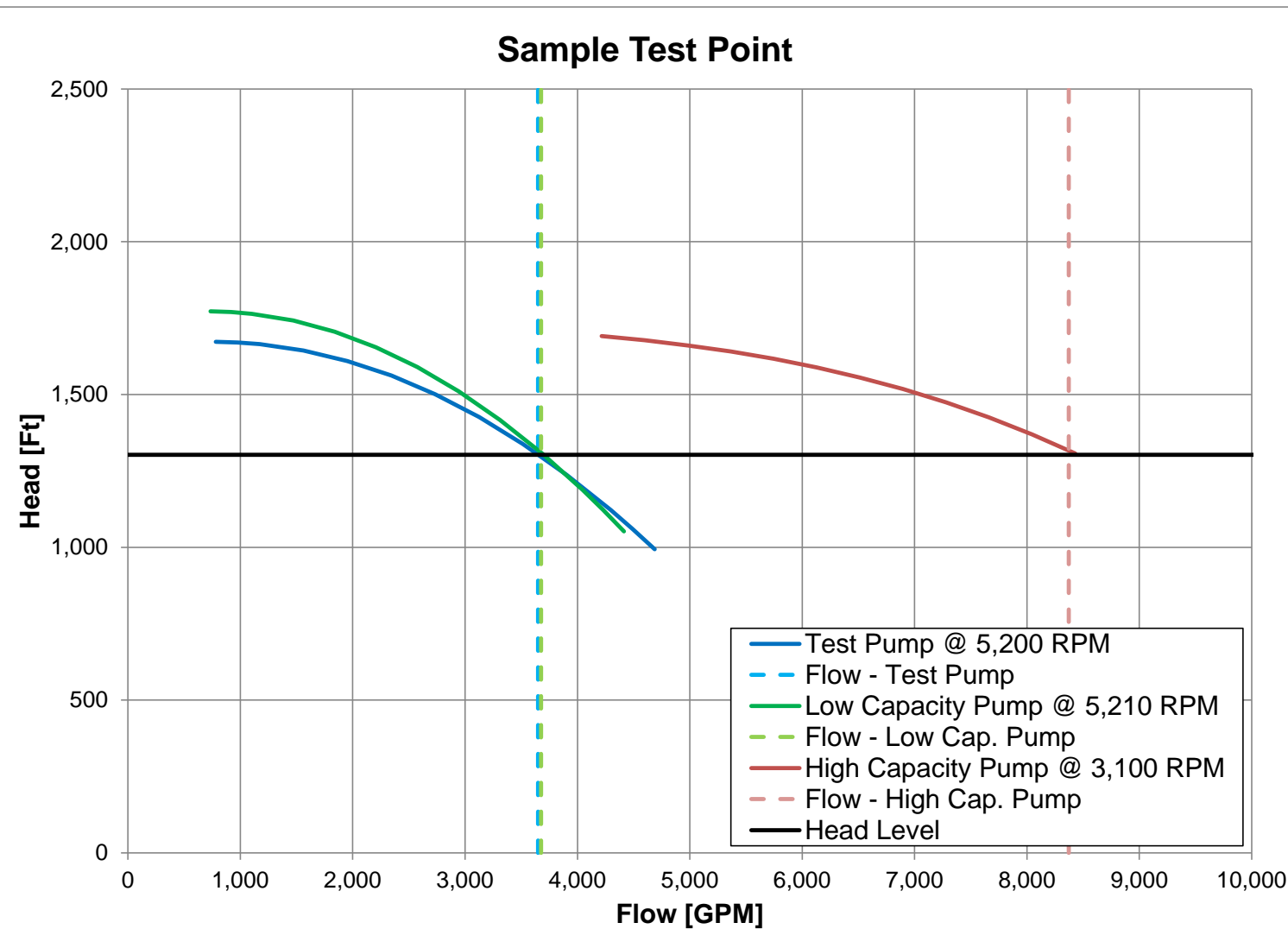

Pipeline Network and Machinery Model

- 1-D pipeline fluid model of the existing facility including L1, L2, and L3 lines
- Used previous pump field measurements to represent pump curves
- Various emulsion of water-in-oil up to 30% water-cut
- Flow, pressure, and temperature field data was previously used to validate the hydraulic model within 1.12%

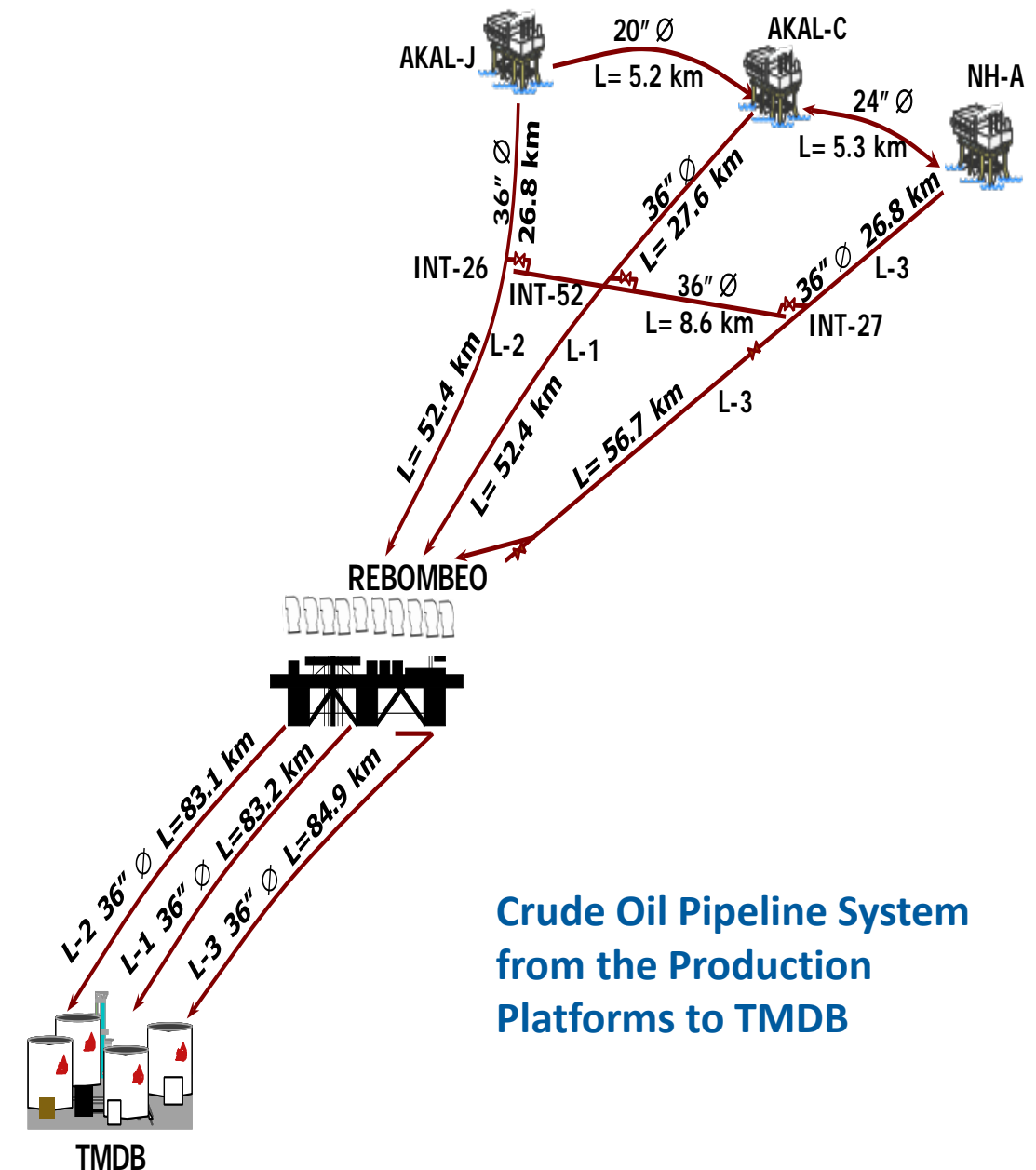

Modeling Results

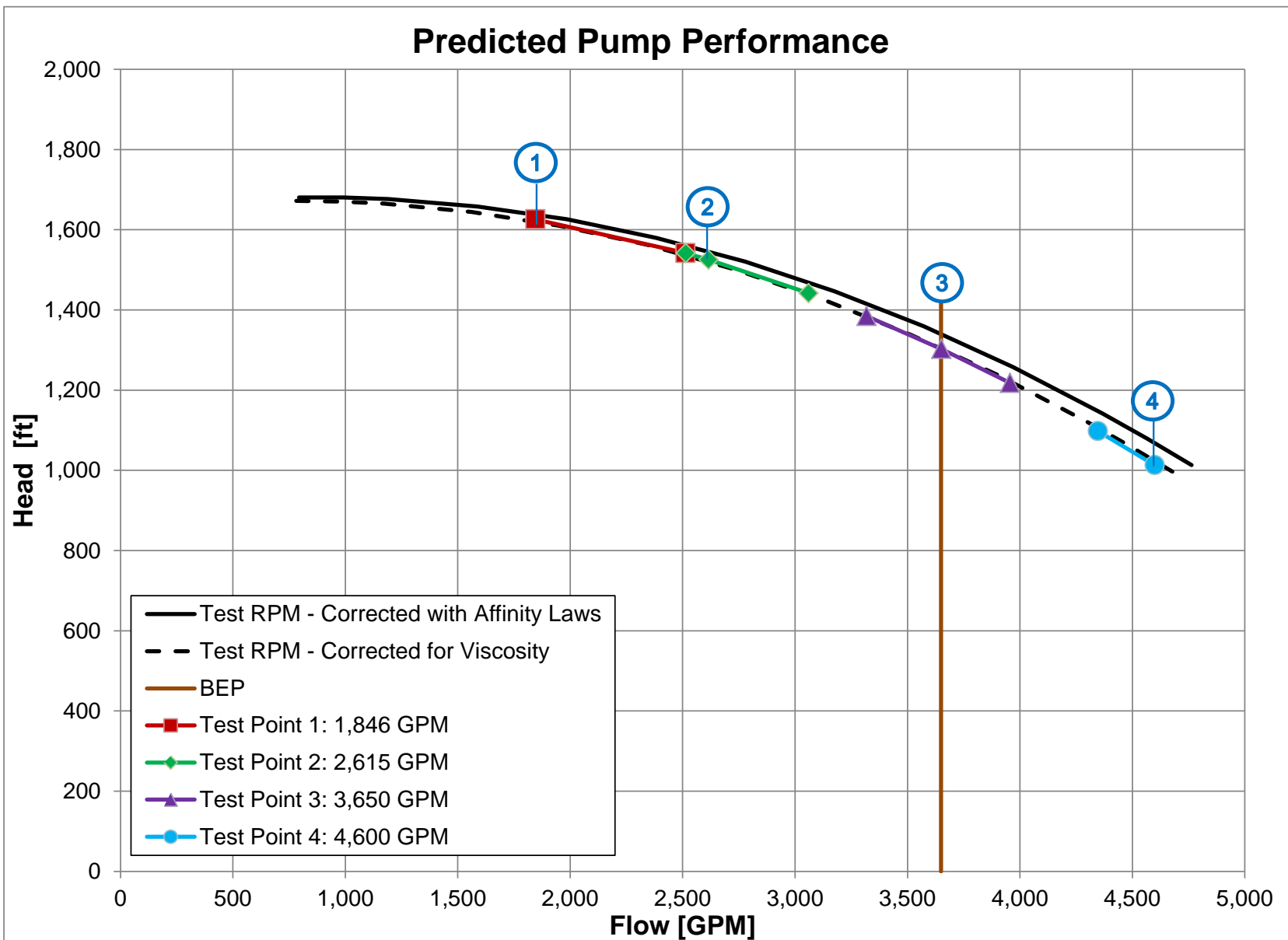

- Modeling demonstrated that test approach of varying speed of adjacent pumps is able to vary flow through the test pump
- However, unable to traverse entire pump curve with this approach
- Traverse of entire pump curve requires a change in platform operation conditions
- Limitation primarily due to platform pressure limits

Test Set-up: Flow Measurements



Ultrasonic Flow Meter

Test Set-up: Pressure Measurements

Suction Pressure



Pump Speed

Discharge Pressure

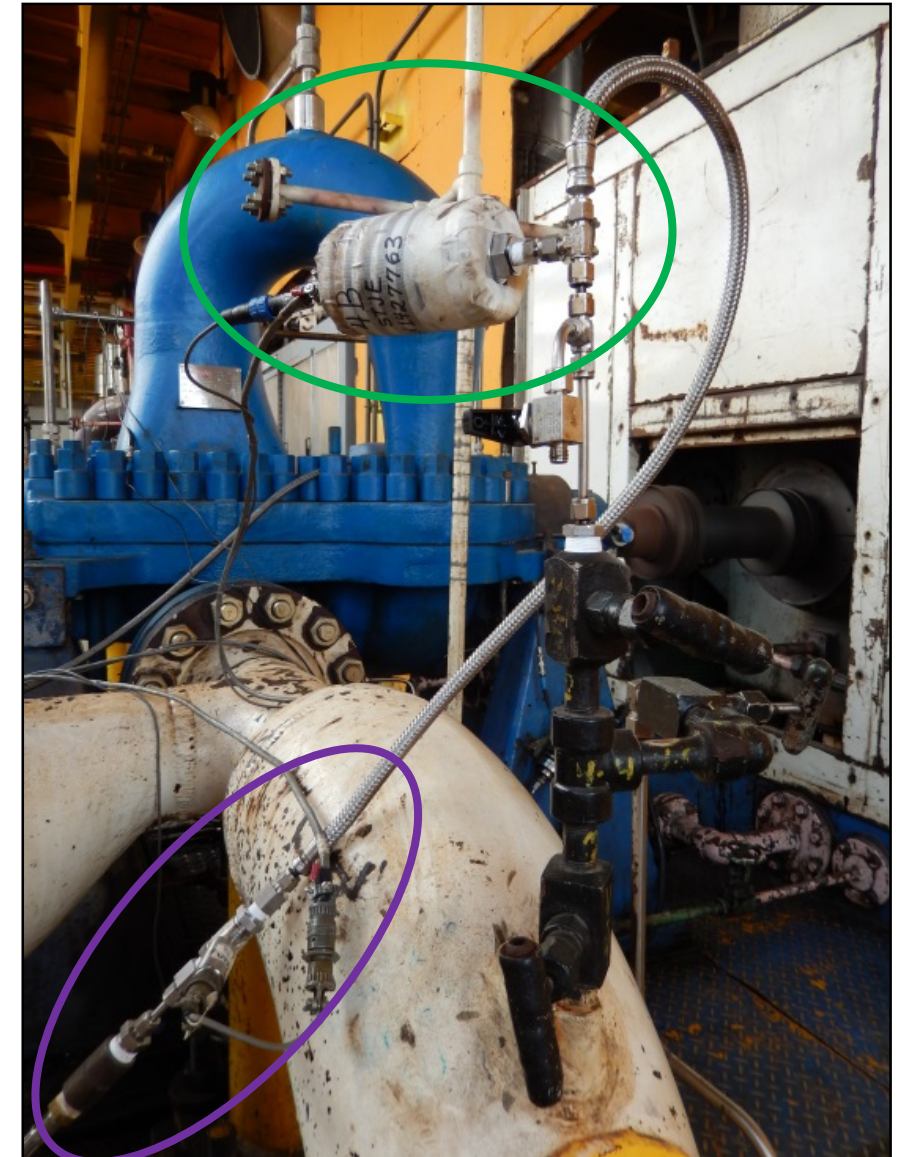

Differential Pressure

Measured Pump Performance

- Only one platform flow condition available for testing – limited to current production
- Performance test was able to traverse a portion of pump curve
- Results used to estimate the pump degradation
- Testing was performed on 3 of the 6 centrifugal pumps

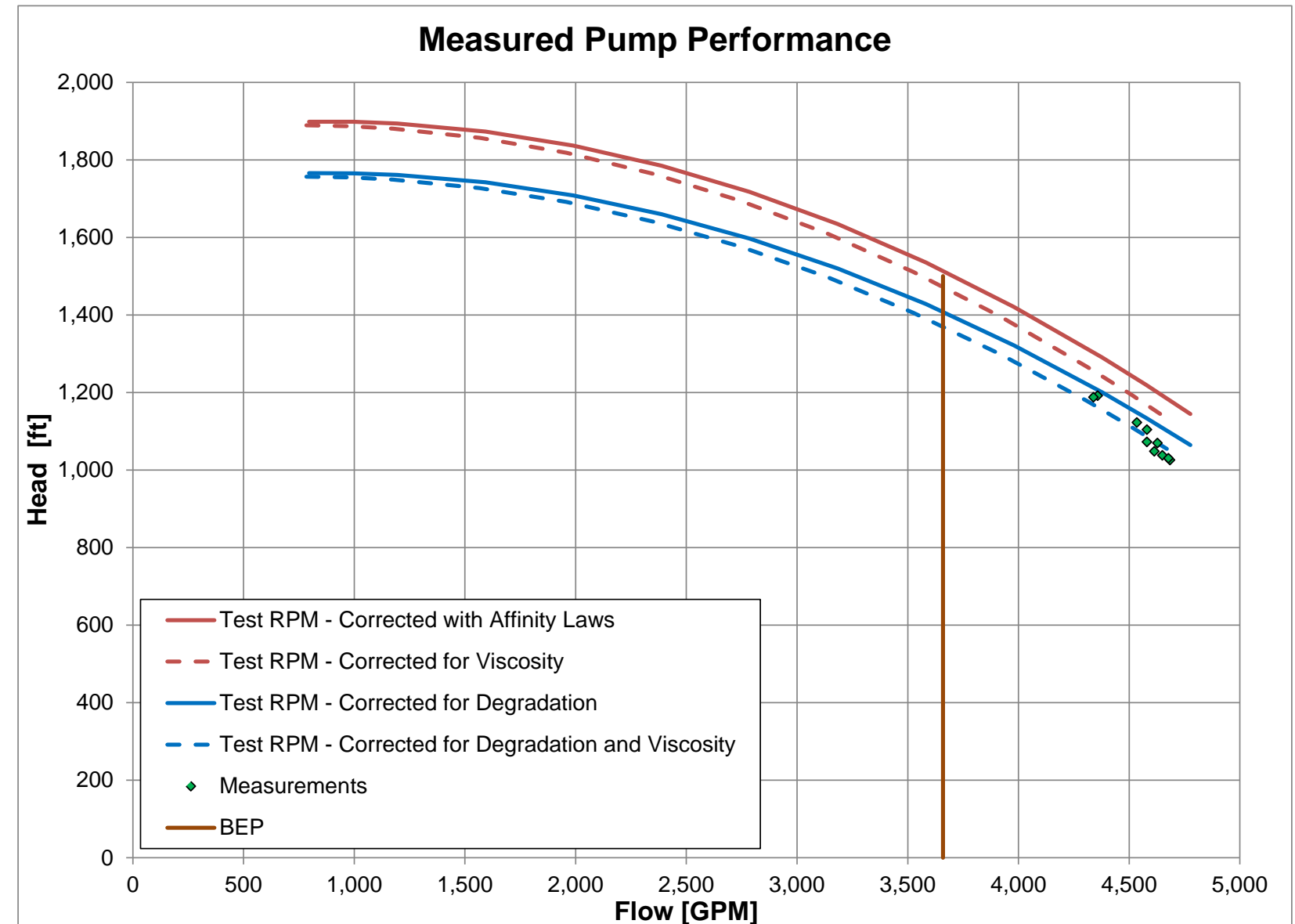

Presentation Overview

- Field Evaluation
 - System Background
 - Performance Testing Approach
 - Pipeline Modeling Results
 - Field Testing Results
- Hydraulic Modeling
- Simulator Development



Hydraulic Modeling Evaluation

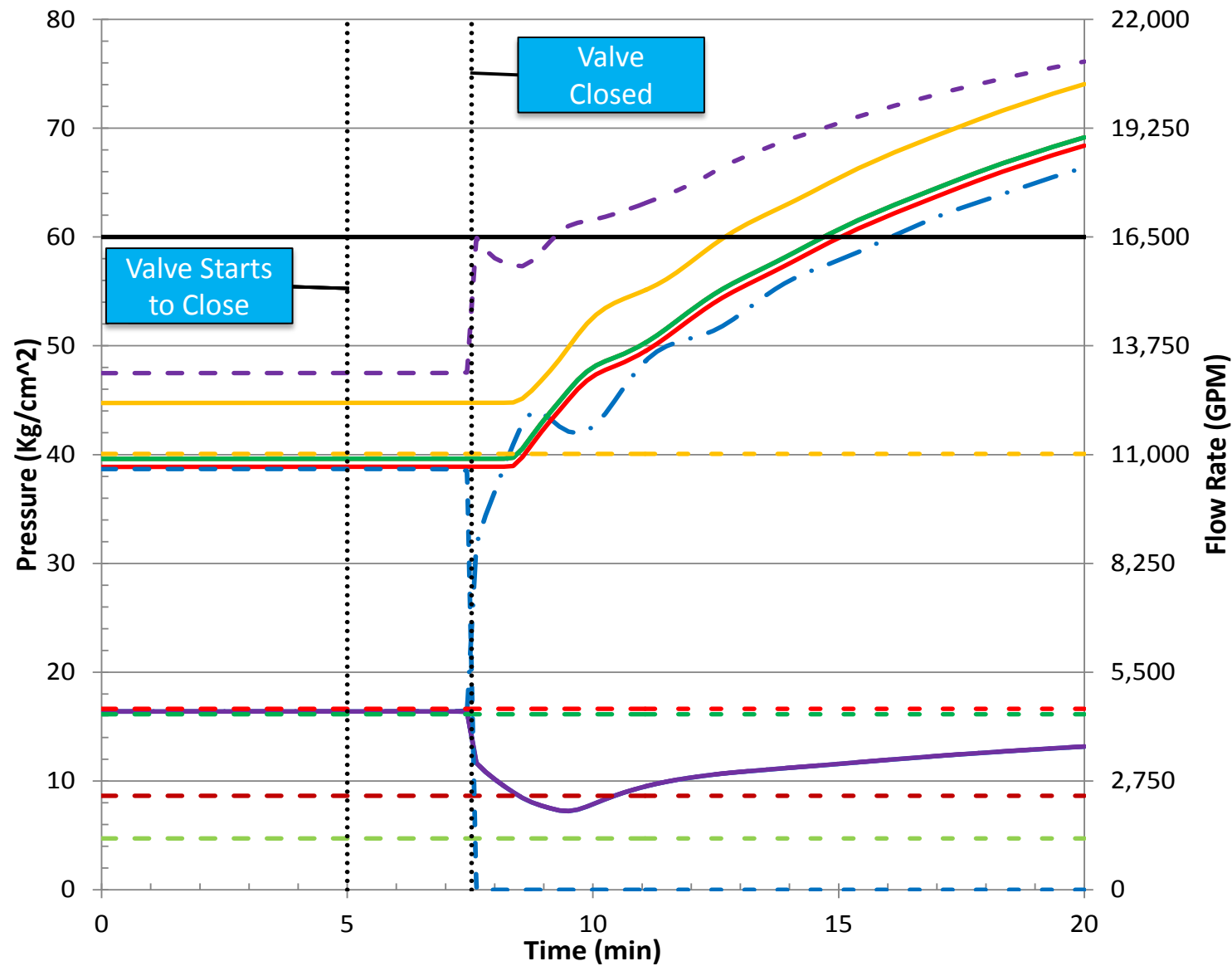

- After performance testing complete, additional simulations performed to predict scenarios that are undesirable for experimentation at an operating platform either due to expense or safety
- Water hammer scenarios used to predict worst-case pressure spikes
- Also simulated changes to system valve configurations

Presentation Overview

- Field Evaluation
 - System Background
 - Performance Testing Approach
 - Pipeline Modeling Results
 - Field Testing Results
- Hydraulic Modeling
- Simulator Development



Purpose of Developing a Training Simulator

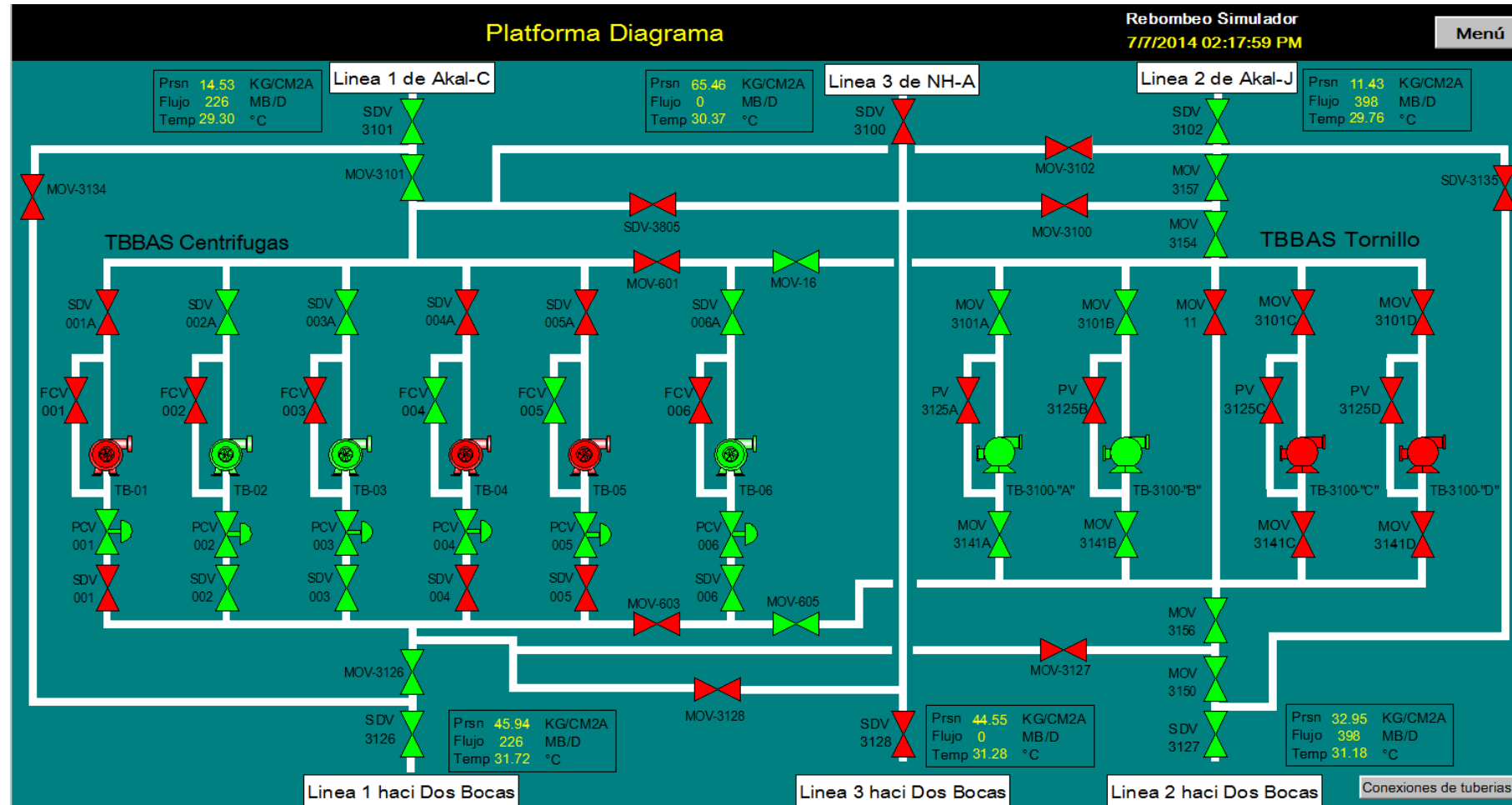

- Safely train operators to use newly installed screw pumps
- Helps platform operators comply with API 1120, ASME B31Q, RP 1161 and RP T-2

Training on the Simulator

- Simulator has screens that **mimic control screens** and a **computational engine** that predicts system response to trainee actions
- Additional screens added to provide operators with insight into the system hydraulics
- Ability to simulate complex procedures such as **start-ups and shutdowns**

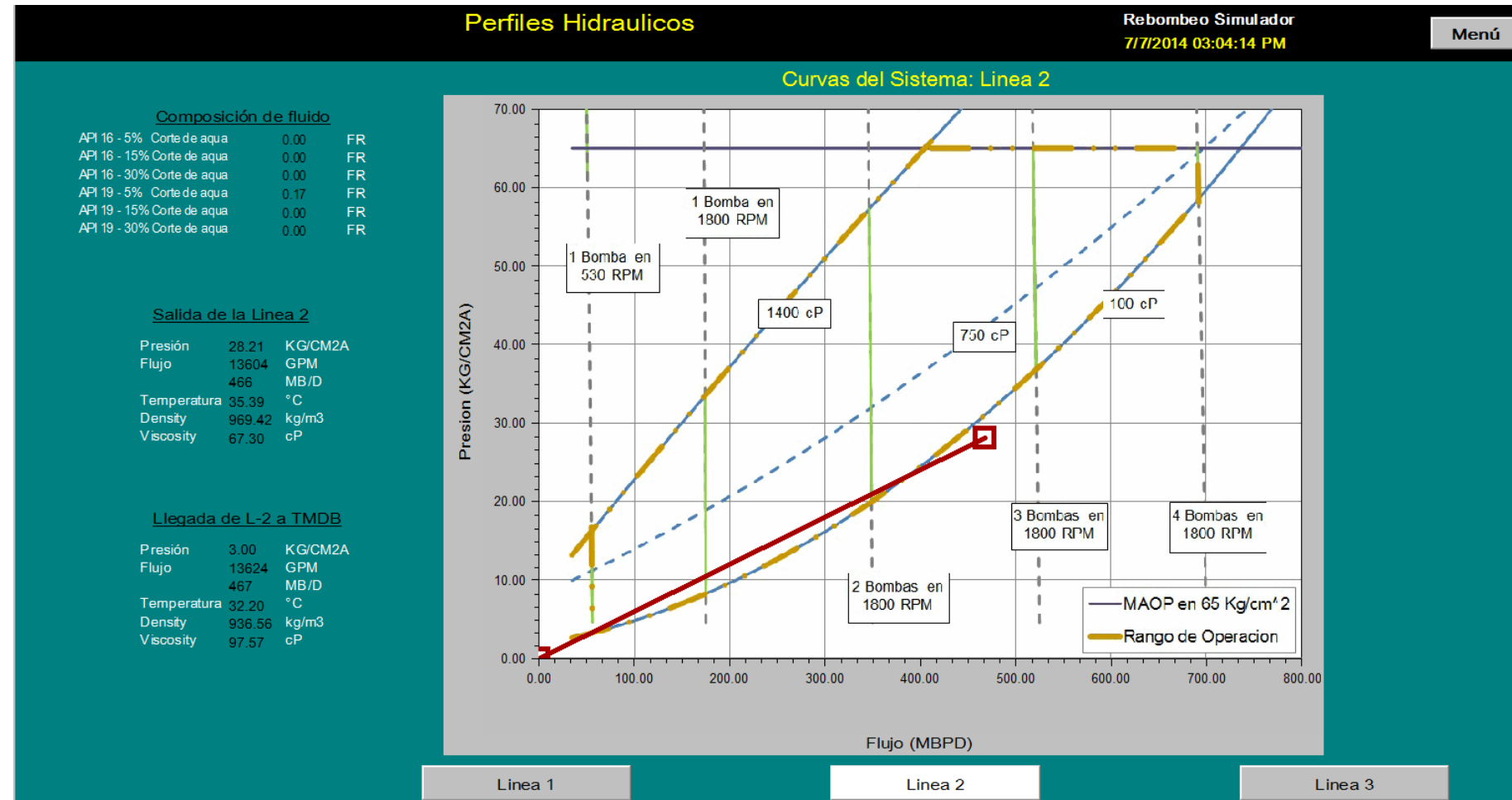

Conclusions

- Field evaluation of offshore pumps was performed
- Pipeline simulations were used to provide insight into test conditions necessary to perform a full sweep of pump curve
- Limited flow conditions in the field resulted in a limited range of the pump curve being tested
- Pump degradation was estimated from the field testing and adopted in the model
- Hydraulic system evaluation used to estimate worst-case water hammer scenarios
- Training simulator was developed to train operators to use newly installed screw pumps



Centrifugal Pump with Shaft Guard On

Thank you for your attention!

I will be happy to address any questions.

Jeffrey A. Bennett

Research Engineer

Jeffrey.Bennett@swri.org



Augusto Garcia-Hernandez

Group Leader

Augusto.Garcia-Hernandez@swri.org