



ASIA TURBOMACHINERY & PUMP SYMPOSIUM  
SINGAPORE | 22 - 25 FEBRUARY 2016  
M A R I N A B A Y S A N D S

## MEETING COMPRESSION TRAIN BASE PACKAGE DESIGN REQUIREMENTS FOR SERVICE ON FLOATING PRODUCTION STORAGE AND OFFLOADING VESSELS

Edward Abraham  
Principal Solid Mechanics Engineer  
Dresser-Rand Company, A Siemens Business  
Olean, NY, USA

Harry Miller  
Director of Emerging Technology  
Dresser-Rand Company, A Siemens Business  
Olean, NY, USA



Edward Abraham is a Principal Solid Mechanics Engineer for Dresser-Rand in Olean, N.Y. He began his working career at Westinghouse Bettis Atomic Power Laboratory in the Shock and Vibration Department doing analyses of shipboard components for the Navy, and verifying the in-house finite element analysis (FEA) code. During his time at Dresser Industries,

he provided FEA support to engineers at Dresser Industry locations and performed numerous FEA analyses for those divisions. At Dresser-Rand, he was the Supervisor of Solid Mechanics for 10 years before transitioning to his present role as Principal Solid Mechanics Engineer. He has performed numerous analyses of turbomachinery components including cases, impellers, lifters, rotors, and base packages. He has also provided extensive support for the Dresser-Rand Wellsville N.Y. Operations' Navy contracts, performing transient non-linear dynamic analyses of components being designed for the Navy. Ed has a Bachelor of Science degree in Engineering from Cornell University in Ithaca, New York.



Harry Miller is the Director of Emerging Technology at Dresser-Rand. His career in turbomachinery began 39 years ago with Dresser Clark, and he has held a variety of design engineering and marketing positions, most recently, as Product Manager of Turbo Products, Manager of Development Engineering and Leader of the DATUM® Centrifugal Compressor

Development Team. His prior work experience consists of four years as a mechanical construction engineer for the Pennsylvania Power & Light Company. He received a B.S.M.E. degree from Northeastern University, and a M.B.A. degree from Lehigh University. His areas of expertise include turbo compressor and gas turbine design and application. He has authored several technical papers and articles, has contributed to and been awarded several patents, and has won the Dresser Industries Annual Technical Achievement Award. He is a member of the ASME, the NLA, and was named an Engineering Fellow at Dresser-Rand.

### ABSTRACT

Typical floating production, storage and offloading (FPSO) compression applications are presented, including drivers and auxiliary equipment, and typical compressor operating conditions. Base packages consisting of centrifugal compressor(s), gear, motor or gas turbine driver, lube oil tank, and auxiliary equipment require extensive analyses to validate design requirements for service on FPSO vessels. Finite element analyses (FEA) are performed to insure that stress and displacement criteria are met. This paper discusses loading conditions that are evaluated including package lifting, transportation loads, short circuit torque, and upset loads. Operating load cases are also analyzed, which include dead weight, FPSO motion, rotor unbalance, torque, nozzle, and wind loads. Modal analyses are performed to ensure that predominant package modes do not lie in the run speed range. Rotor unbalance forced response analyses can be performed to ensure that amplitudes at key locations remain within allowable vibration criteria. Typical FEA models and analytical procedures are presented. The use of the analytical results to assist in selecting design modifications is discussed. The paper emphasizes the importance of gathering information early in the design cycle. This includes ship structural stiffness at the anti-vibration mount (AVM) locations, AVM stiffness, and load specifications including wind, wave, upset, and transport loading, and coupling capability. Finally, the paper presents a design change that allows for significant footprint reduction of the overall package.

### INTRODUCTION

Floating production, storage and offloading (FPSO) vessels are used throughout the world for the processing of oil and gas, for oil storage and for off-loading to a tanker or through a pipeline. The FPSOs can be subject to high winds and accelerations from the pitch, roll and heave of the vessel. Continued safe operation of the on-board equipment under both normal and adverse conditions is essential. Base packages typically consist of a compressor, gear and driver and are mounted on three anti-vibration mounts (AVM) to minimize



the loads and displacements being transmitted into the base package. The three-point mount bases require the analyses of a significant number of operational and upset load conditions to ensure safety and sustained equipment operation. Transport and package lifting must also be evaluated. The normal operating loads include dead weight, acceleration due to FPSO, pitch, roll and heave, unbalance, torque, wind, and nozzle loads. The upset loads could include motor short circuit torque, maximum acceleration and survival wind loading. A modal and harmonic response analysis may also be required to ensure that response at key locations on the package remain within acceptable vibration limits due to rotor unbalance. It is important to do these calculations early in the design phase as design changes may be required to satisfy criteria.

The analytical procedures presented can apply to any driver, although motor drives are presented in most of the examples. These procedures also apply to either a standard gear or a variable hydraulic gear. The three-point mount examples also show the use of AVMs. The procedures could also apply to Gimbal mounts. Single body compressor train examples are also shown in the examples, but the procedures presented have also been applied to base packages with multi-body compressors.



Figure 1. Typical FPSO layout. (Mastrangelo et. al., 2014).



Figure 2. Agbami FPSO at the fabrication yard in Korea.

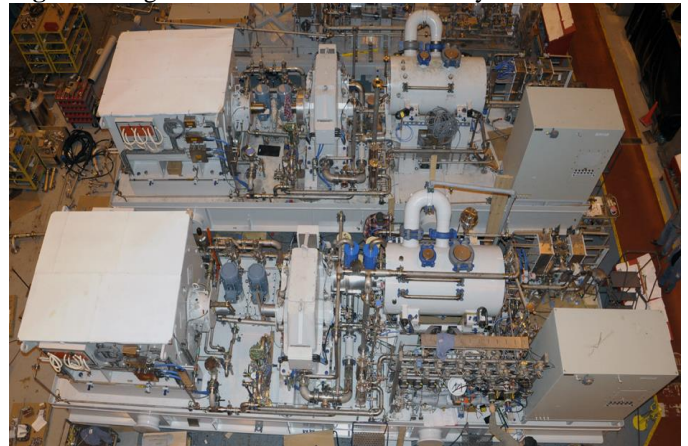


Figure 3. Two motor-driven, gas injection compressor trains showing the drive motor, speed increasing gear and compressor mounted on a common baseplate, together with a base-mounted lube oil system, dry gas seal system and local control panel; this single-lift package is destined for an FPSO offshore Brazil.



Figure 4. A typical aero-derivative gas turbine-driven electric generator destined for operation on an FPSO.



**Figure 5.** A three case gas reinjection compressor train driven by an aero-derivation gas turbine destined for installation on an FPSO.

### FPSO WORLDWIDE DISTRIBUTION AND OPERATION

FPSO vessels first emerged in the mid-1970s. Since then, 186 FPSOs have been commissioned into service; 147 of these remain in operation today. FPSOs are widely deployed offshore in Latin America, Asia, West Africa, the Middle East, the North Sea, and most recently in the Gulf of Mexico. Use of FPSOs appears to be still growing. The larger FPSOs have storage capacities in excess of 2 million barrels of oil, and living accommodations for crews of between 100 to 200 people. They are also capable of processing up to 20 mmsm<sup>3</sup>/d (million metric standard cubic meters per day) of natural gas and injecting up to 300 mbwpd (million barrels of water per day). [1]

A typical FPSO layout is shown in Figure 1, and an actual FPSO is shown in Figure 2. There can be several types of turbomachinery on-board, including gas injection compressors, gas lift compressors, export gas compressors, gas boosting compressors, and fuel gas compressors. A view of two motor-driven compressor trains is shown in Figure 3. There may also be water injection pumps, and usually several gas turbine-driven power generation trains, as shown in Figure 4. The compressors and pumps are usually driven by mechanical drive gas turbines or electric motors. In most instances, a speed increasing gearbox is also used between the driver and the driven equipment. It is most common to mount the compressor, gear and driver on a common, single-lift baseplate. The baseplate is fabricated from structural steel and contains mounting pedestals for each piece of equipment. In some cases, all of the auxiliary equipment needed to support the

compressor and its drivers, such as a lubricating oil system, a dry gas seal system, instrumentation, and local control panel, are also mounted on or within the baseplate. Some FPSOs have utilized steam turbine driven electric generator sets. Figure 6 and Figure 7 show two 27 MW and three 24 MW steam turbine driven generators respectively. Both are mounted on the top decks of their respective FPSO's.



**Figure 6.** Two 27 MW steam turbine generator sets on board the Knock Allan FPSO for power generation.



**Figure 7.** Three 24 MW condensing steam turbine generator sets on board the Peregrino FPSO.



FPSO technology has matured significantly over the years, with the vessels gradually growing larger and more complex. As many as 50 risers can be connected through its mooring system and they have more sophisticated processing capability, with the latest evolution being the introduction of natural gas liquefaction to an FPSO. When an FPSO is utilized for the production of LNG it becomes known as an FLSO. A typical FLSO is shown in Figure 8. The first FLSO is undergoing commissioning at this time but several more FLSO's are in the planning stages. This innovative method for producing oil and natural gas has several advantages compared to conventional offshore platforms, the primary of which was cost effective production of smaller sized reservoirs, the ability to operate in waters considered too deep for conventional platforms and portability. As such, many FPSOs can disconnect from their risers, allowing them to be moved away from hurricanes and severe storms. [6] The technology also had many challenges to overcome such as mooring system development, turret system development, flexible riser systems, safe handling of flaring, government regulations, financing, and coping with wave motion.

This last challenge, coping with wave motion, deserves further discussion. Figure 9 illustrates the peak tilt angle experience by a typical FPSO during a six-hour time period. Note the random fluctuation of the tilt which achieves a maximum value of more than 18 degrees. In order for the reader to better understand the impact of tilt angle, the cruise industry considers a tilt of 15 degrees to be extremely severe. In such events, cruise passengers are usually injured because of falls and from being hit by sliding objects. Some have even been thrown overboard. Therefore, on an FPSO, being able to properly mount and secure rotating machinery is of paramount importance. The mechanical design of the baseplates upon which the turbomachinery is supported, as well as the mounting of the

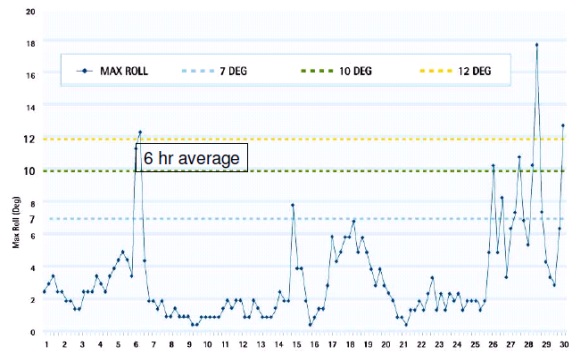
**Figure 8.** FLSO Design Concept. Used by permission from Excelerate Energy Inc.

baseplate to the topsides deck, are critical. The baseplate not only needs to properly secure and support the rotating equipment and the loads mounted on it, but it must also be able to handle the forces and moments imposed by the FPSO hull and deck motions.

DET NORSKE  
NEGT STØRST I A NORSK GOSEKJEL



### Horrible motion characteristics

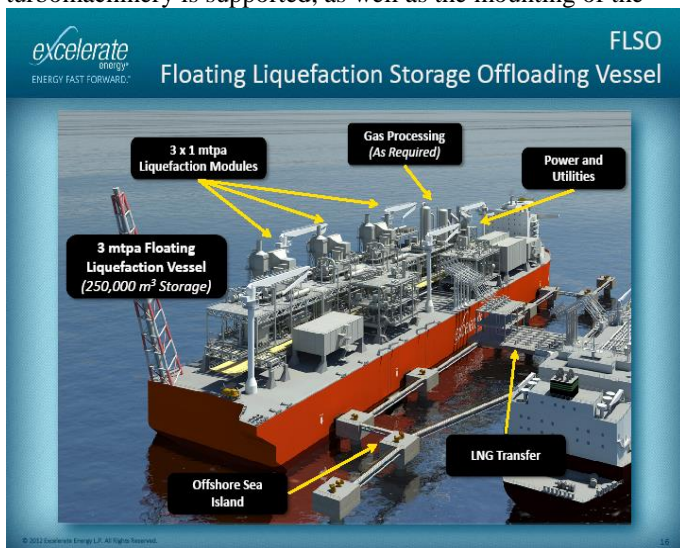


From "History of FPSO's by Kaare Gisvold - Det Norske

**Figure 9.** Wave motion roll angle experienced by an FPSO (Gisvold, 2014).

### TYPICAL BASE PACKAGE DESIGNS

The typical base package design uses torque boxes or torque tubes to provide torsional and bending stiffness. The flexural stiffness is required for dead weight, package lift and ship heave. The torsional stiffness limits the overall base package twist resulting from both vessel pitch and roll and from wind loads. Adequate torsional stiffness is required to limit the relative displacements between shaft ends. This relative displacement must be limited both on the high speed end between the compressor and high speed gear, and on the low speed end between the driver and the low speed gear. Adequate bending stiffness is required for package lifting and ship heave. Figure 10 shows a motor, gear and compressor package supported by a torque box design. It has the lube oil console cantilevered off the end of the base. A top view showing the base (skid) structure is shown in Figure 11 The primary flexural and torsional member is the fabricated torque box. The bottom view shown in Figure 12 shows the positioning of the three anti-vibration mounts, AVMs. There are two AVMs under the

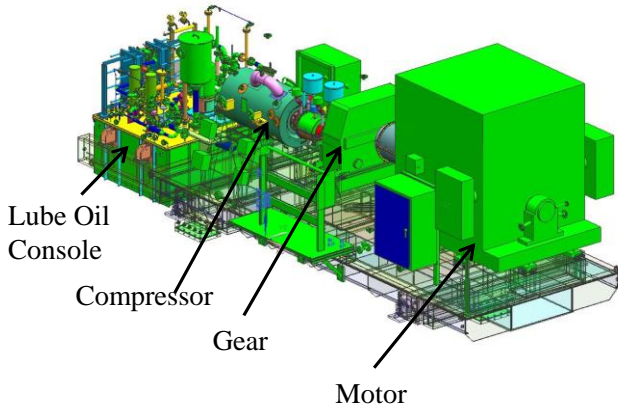




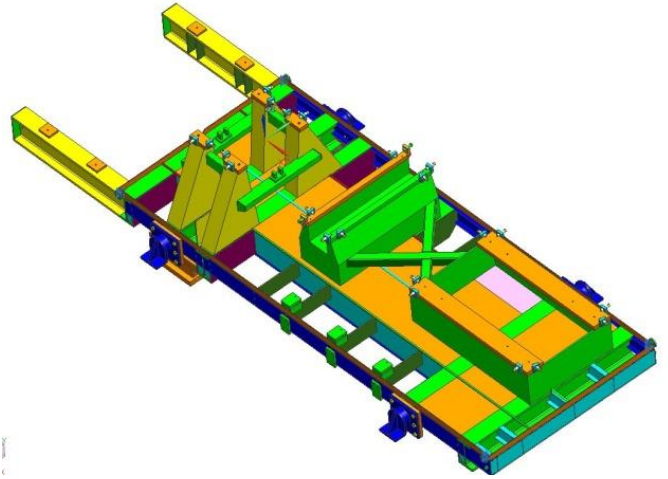
compressor and one under the motor.

An analytical model of a torque tube concept is shown in Figures 13, 14 and 15. This package includes two compressors and a gear. A top view of the base only is shown in Figure 14. It is bolted to another base that includes the driver, so this package only includes the two AVMs under the compressor as shown in the bottom view in Figure 15. The base with the driver includes one AVM under the driver. The torque tube provides the flexural and torsional stiffness.

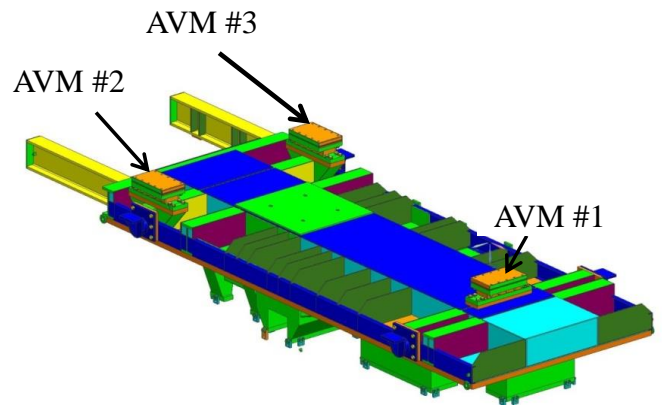
A third design concept does not use either a torque tube or a torque base; instead, large, wide flange beams are used on the perimeter of the base and for the main transverse beams. This design typically results in higher torsional and bending stiffnesses, but also results in a heavier base. Figure 16 shows a compressor, gear and motor package supported by wide flange beams with the lube oil console cantilevered off the end of the base. The flexural stiffness is provided through the two large wide flange beams that run in the longitudinal direction. These two beams also provide the support for the cantilevered lube oil console. A top view of the base only is shown in Figure 17. A bottom view of the base only showing the positioning of the AVMs is shown in Figure 18. The longitudinal beams together with the transverse beams provide the torsional stiffness.



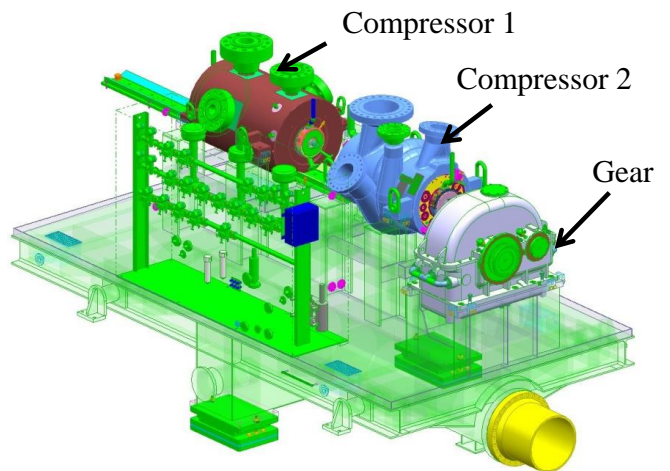
**Figure 10.** Typical torque box base package design with motor, gear, compressor and lube oil console.



**Figure 11.** Top view of torque box base



**Figure 12.** Bottom view of torque box base



**Figure 13.** Typical FPSO base package with torque tubes.

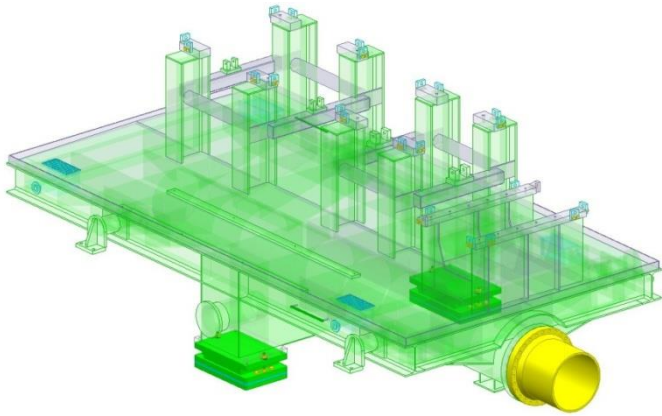


Figure 14. Top View of Base Showing Torque Tubes

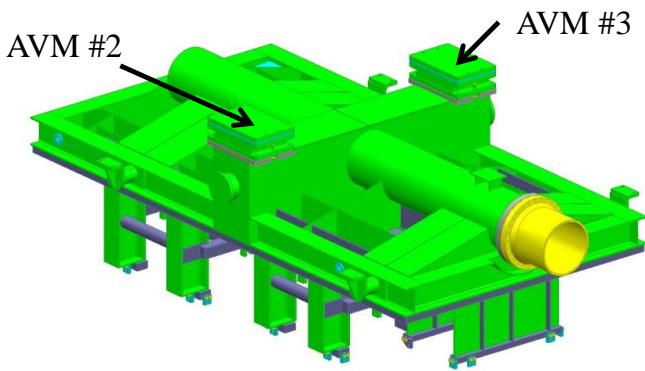


Figure 15. Bottom view of Base Showing Torque Tubes

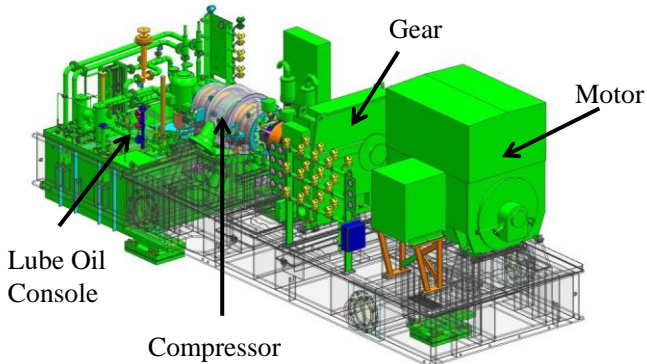


Figure 16. Typical FPSO base package with wide flange beams

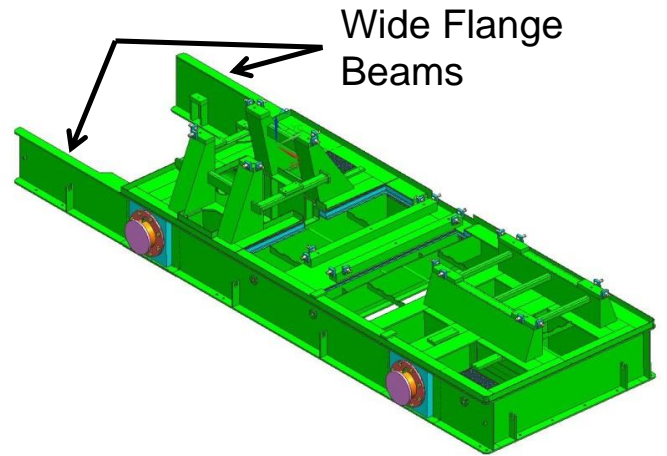


Figure 17. Top view of wide flange beam base

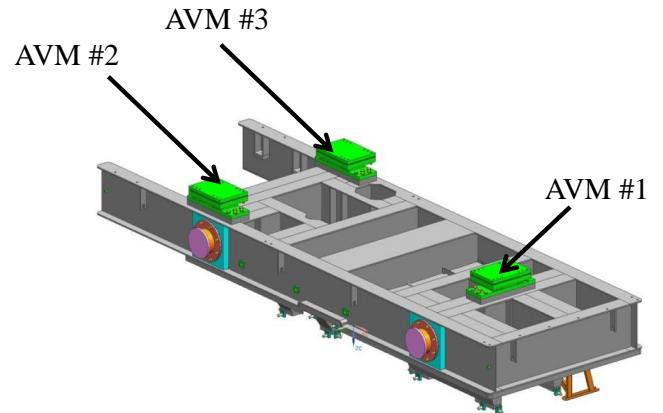


Figure 18. Bottom view of wide flange beam base

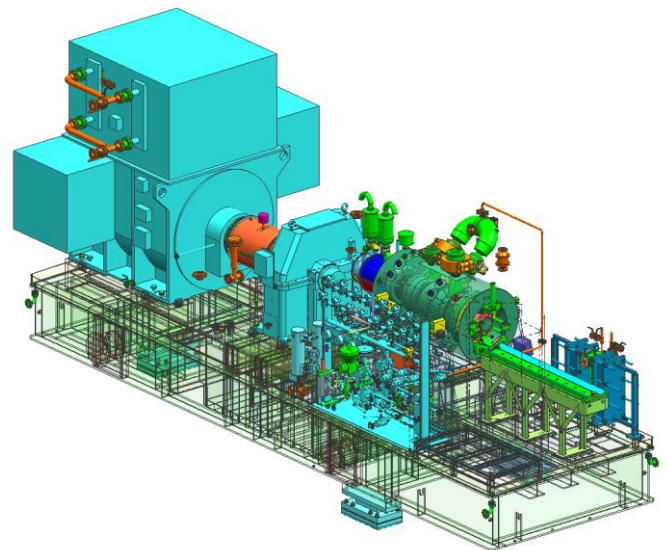
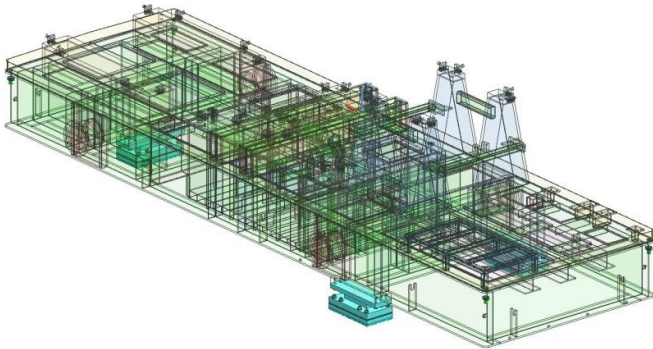
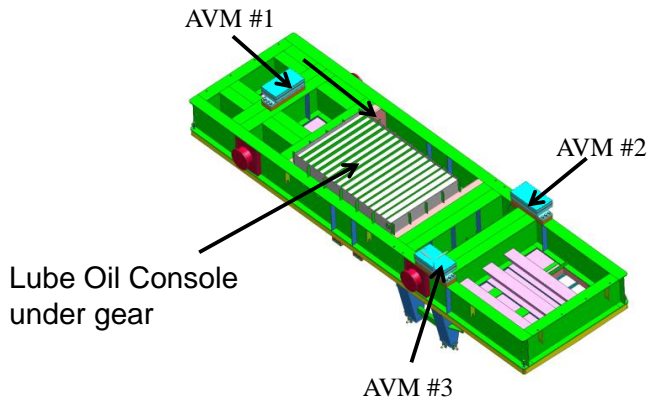


Figure 19. Wide flange beam base with lube oil console under the gear.



**Figure 20.** Top view of wide flange beam base with lube oil console under the gear



**Figure 21.** Bottom view of wide flange beam base with lube oil console under the gear

### BASE DESIGN CONSIDERATIONS

A number of considerations affect the base design. The required flexural strengths must be met, and this requires the detailed analyses discussed in this paper. Bases fabricated from wide flange beams have been shown to reduce shaft end relative displacements, but they have also been shown to be 18% to 22% heavier. It is important that the shipbuilder has a good estimate of the total package weight.

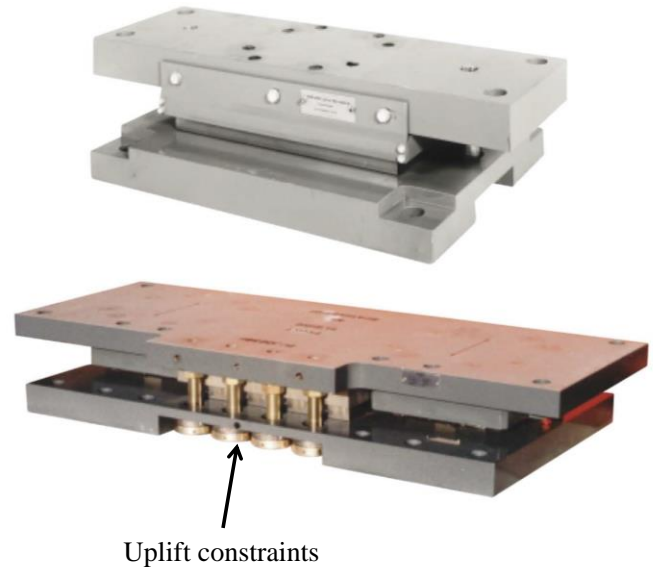
Costs of material and fabrication including welding are important. Total base costs are typically obtained from a number of base fabricators. The costs to manufacture a beam base versus a box or torque tube base varies by manufacturer, and this is largely affected by the types of bases that they are accustomed to fabricate .

In many cases it advantageous to include the lube oil console under the gear as opposed to cantilevered off the end of the base. Figure 19 shows a base beam with the lube oil console

under the gear. Top and bottom views of the base are shown in Figures 20 and 21. The entire base package is shorter, and space is at a premium on the FPSO. The other advantage is that it is easier to meet the API 2.5° drain requirement from the gear to the lube oil console. Typical ship roll, pitch and heel are 12°, 3° and 1° respectively. For a 3.0° ship pitch, the pipe slope must be 3.0° + 2.5° or 5.5°. If the lube oil console is off the end of the base, it might be too long to achieve the required drain angle. If the ship roll is specified as 12.0°, then your drain the lateral direction would be 14.5° if the pipe needs to be run laterally for a certain distance. The torque tube design can also accommodate a lube oil console under the major equipment. However, the disadvantage of including the lube oil console under the gear for a torque tube design is that there is no large center torque tube extending from one end of the base to the other. It must be replaced by two smaller torque tubes that run along the sides of the lube oil console.

### THREE-POINT MOUNTS

Three mounts are used for each package, and these are the key to the successful operation of the package on-board the FPSO. Typical AVM designs are shown in Figure 22.



**Figure 22.** Typical AVM designs

The top pad of each AVM is bolted to the base and the bottom pad is bolted to the ship deck. Wire mesh cushions (WMCs) are used to provide the stiffness. These are stacked and positioned to provide the proper stiffness in each direction per the package requirements. The AVMs also provide rotational flexibility. Cushioned uplift restraints provide stiffness in the vertical uplift direction during ship heave or during ship pitch and roll.



The vertical movement at the mount position is limited to 3mm to 6 mm. All mounts can Gimbal by  $.35^\circ$  in all three rotational directions. For a 4.6 m wide base, one side could displace up by 13 mm and the other side could displace down by 13 mm. WMCs have high damping (15% to 20% of critical damping). Three-point mounts are easier to install than a multi-point system, which is hard to get right. The bolts between the base and pads and between the pad & deck are slip critical. Shear pins are used in some designs.

The advantages of an AVM over a Gimbal mount are:

- The AVMs are generally considered to offer better vibration isolation.
- The AVM is not as high as a Gimbal as Gimbals raise the height of the overall package.
- AVM does act as a Gimbal in that it does allow rotation, but the rotation is limited compared to a Gimbal.
- There is no significant cost difference.
- If there is no sliding large forces can be transmitted into the skid from the deck, although Gimbals can be designed with sliding.

The advantages of Gimbal mounts are:

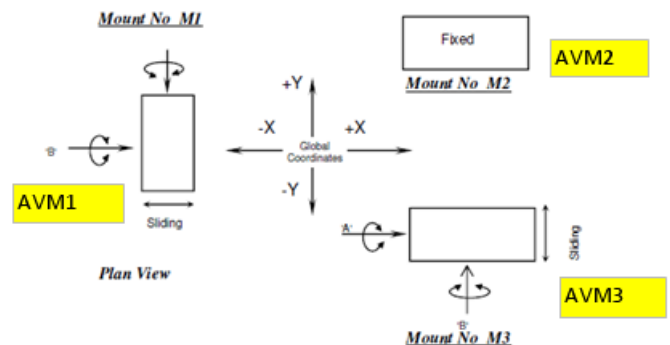
- More rotation is allowed if needed ( $15^\circ$  for Gimbal vs.  $.375^\circ$  for AVM). This is advantageous in situations where there is higher rotation between the top and bottom plates of the mounting system,
- Gimbals do not add to displacements at pipe connections and there is no relative (dynamic) movement between the deck and the package.

AVMs are more often used because of their high damping and successful experience with their use.

The AVMs provide stiffness and damping in the axial, lateral, and vertical directions. Figure 23 shows typical AVM placement. Many early designs included two AVMs under the driver and one under the compressor; however, designs with two AVMs under the compressor and one under the driver have been shown to more easily meet displacement criteria. One reason for this is that incorporating two AVMs under the compressor limits the compressor rotation due to the nozzle loads, vessel pitch and roll, and other operational loads. Additionally, displacement limits are more stringent for the high-speed coupling on the compressor side than for the low-speed coupling on the driver side.

The AVMs isolate the base package from the vessel hull and deck in two ways. First, the AVMs are heavily damped, decreasing the amplitude of base package displacement. This large frictional damping is provided by the WMCs. As a result of this damping, amplification factors for an AVM are typically

2.5. As a comparison amplification factors for coil springs and rubber are 20 and 10 respectively. Damping is lower for vibration loads like rotor unbalance, and very good vibration isolation between the base package and the deck is realized. The AVMs are particularly effective in preventing structure born noise from being transmitted into the package. Second, sliding is allowed in two directions as shown in Figure 23 where AVM #1 is allowed to slide in the axial (X) direction and AVM #3 is allowed to slide in the lateral (Y) direction. This sliding prevents deck twist from being transmitted into the base package. As the deck bends and twists, the package has the capability to slide in the axial and lateral directions, minimizing the twist and bending that are transmitted into the base. The AVM sliding is activated under normal operational loads and upset loads. Sliding does not occur as a result of vibrational loads because the smaller vibrations loads cannot overcome the friction. For this reason, the sliding is activated in the analytical model for the static analyses of the operational and upset loads. For dynamic analyses (harmonic response) the rotor unbalance loads are not high enough to overcome the friction, even in the sliding direction. The three-point mount also serves to keep the package level.



**Figure 23.** AVM fixed and sliding directions to isolate base package deflection from FPSO deck twist and bending.

Figure 24 shows three AVMs ready to be shipped. They are marked as sliding or fixed.





Figure 24. AVMs ready to be shipped

A typical arrangement of base packages on an FPSO deck is shown in Figure 25. The axial direction of the equipment is generally installed parallel to the ship longitudinal direction, and the package lateral direction is parallel to the ship athwart ship direction. The vessel deck stiffness under each AVM is provided by the shipbuilder for inclusion in the analytical model. The vertical stiffnesses of the deck at the AVM locations are provided by the shipbuilder as shown in the table. If not provided, deck stiffnesses from similarly sized jobs are used until the final deck stiffnesses are available. Including the deck stiffness in the operational and upset load analyses (pseudo-static analyses) have been shown to increase shaft end relative displacements by as much as 8%. Therefore, it is conservative to include them.

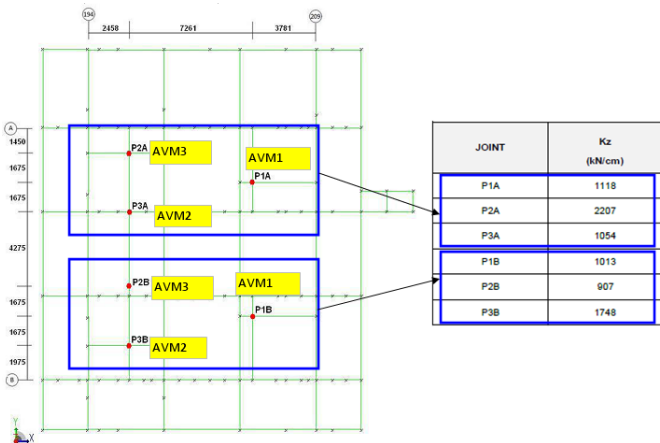


Figure 25. FPSO deck location where stiffness is required

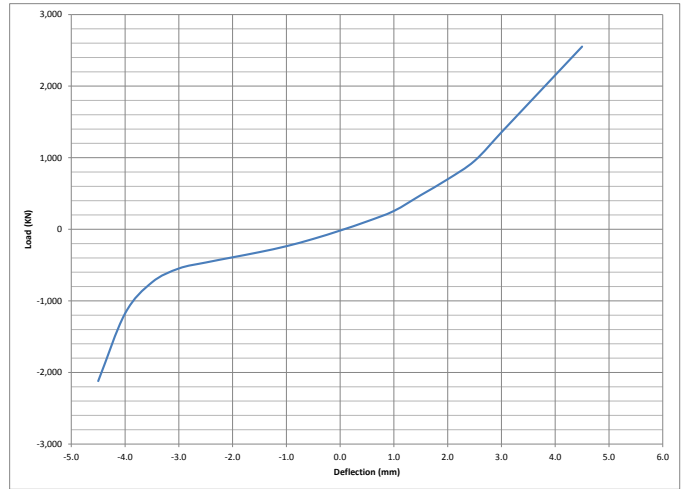


Figure 26. AVM load versus deflection curve supplied by AVM vendor.

The AVM stiffness values are determined from load-deflection curves, as shown in Figure 26. The individual wire mesh cushions are tested to determine their load versus deflection curve. The above load versus deflection curve is then determined analytically based on how the wire mesh cushions are stacked and arranged inside the AVM. A linear stiffness value is extracted from this curve and used in the analysis. This is accomplished by using the tangent stiffness at the typical load. The AVM vendor requires load data on each AVM for all load cases in order to properly design the AVM. The AVM is designed and built concurrently with the base build and the analysis. Therefore, preliminary values of AVM stiffness are employed early in the analysis phase. This can be accomplished in one of two ways. AVM load deflection curves from similar packages can be used, or the AVM stiffness can be estimated. Since the AVMs are designed to give a response of 12 to 15 hertz in the vertical direction, the preliminary vertical stiffness for each AVM can be calculated from the following relationship:

$$F_n = \frac{1}{2\pi} \sqrt{K_v/M}$$

Where:

$K_v$  = AVM stiffness in vertical direction

$F_n$  = 12 to 15 hertz

$M = R/g$  = total mass supported by AVM  
( $R$  = AVM vertical reaction)

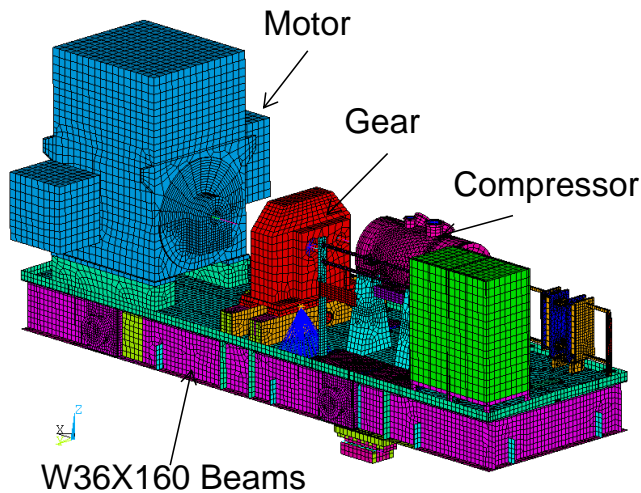
The AVM load versus deflection curves (such as the one in Figure 26) are typically supplied late in the analysis phase. Then, the most critical cases are rerun using the final AVM



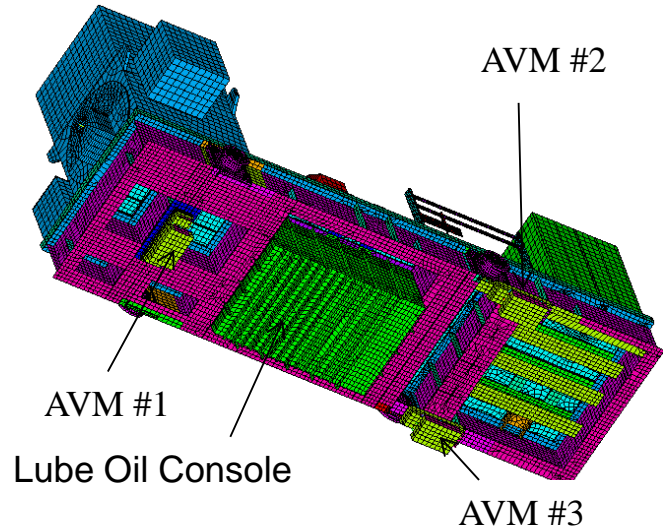
stiffness values. If the preliminary AVM stiffness values are adequately estimated, the final results typically do not vary from the preliminary results by more than 1 or 2 percent.

### FINITE ELEMENT ANALYSIS (FEA)

Hundreds of hours are required to perform the analyses. Gathering the required data, developing the FEA model, setting up and running scores of load cases, determining the worst case combination of loads, and evaluating results are all time consuming. Gathering of the required data is discussed later in this paper. Significant time reduction has been realized in the model development phase; additionally, programs have been developed to automatically determine the worst case combination of nozzle loads and all operating loads. These automations are also discussed later in the paper. Views of the FEA model created for the base design from Figures 19 through 21 are shown in Figures 27 and 28.



**Figure 27.** Typical FEA model of FPSO base package with large I-beams and no torque tubes.



**Figure 28.** FPSO base package with lube oil console under the gear to reduce deck area required – bottom view.

Simplified models that have been used by some consultants in the past would include rigid elements to represent the rotors that were attached directly to the tops of the pedestals. These types of models are less accurate for the prediction of shaft end relative displacement. Additionally, they cannot be used to perform the unbalanced forced response analysis that is used to predict amplitude of vibration at the feet of the major equipment. A number of FEA model details are included which result in a more accurate model. First, all rotors are modeled similar to the modeling used for rotordynamic analysis. Stick-type (beam or pipe) elements are used to represent the stiffness and distributed mass of the compressor, gear and motor rotors, as shown in Figure 29. Lumped masses are used for rotating components (e.g., impellers) with all appropriate mass and mass inertias assigned. Rotordynamic model inputs for the compressor can be edited and read directly into the FEA code. Bearing stiffness is modeled with horizontal and vertical spring type elements that run from the bearing locations on the rotor model to an appropriate location on the case model. The bearing damping is not included. If included in the design, keel blocks and sliding between the pedestal and the compressor foot should be modeled. The helps to more accurately predict the position of the rotor due to the loads applied and hence provided a more accurate shaft end relative displacement computation. These modeling details are shown in Figure 30.

A typical lube oil console model is shown in Figure 31. Lumped masses are included to represent the weight of the oil. These lumped masses are attached at appropriate locations on the lube oil console FEA model. Some initial welded-in lube oil consoles have been found to add to the torsional rigidity of the base; however, analyses indicated that this additional rigidity



was not required. Bolted-in lube oil consoles have been found to be a better design. This also eliminates the need to evaluate the thermal stresses between the lube oil console and the base beams.

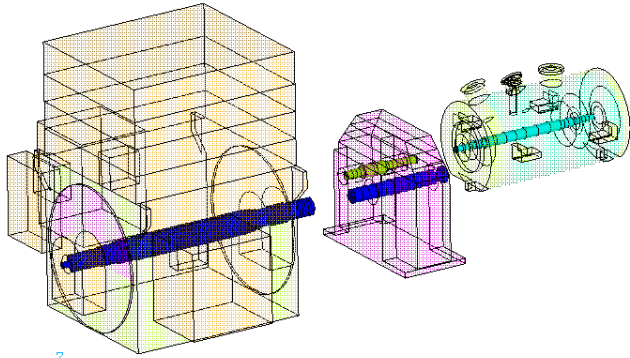


Figure 29. Rotor modeling.

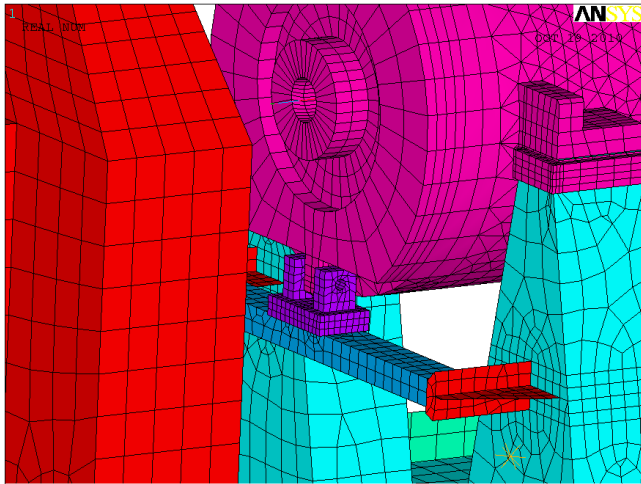


Figure 30. Details of FEA modeling: keel block and pedestals.

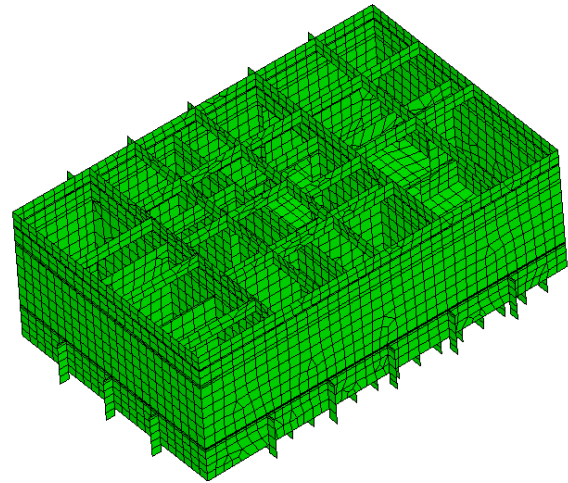


Figure 31. Details of lube oil console modeling.

Meshing of the base beams, torque box or torque tube, gussets, plates, deck plate, and pedestals are done with shell elements that are assigned the proper plate thickness. The base beams may also be modeled with beam-type elements; however, modeling with base beam elements is considered to be somewhat less accurate because of the difficulty in adequately connecting the beam elements to the equipment pedestals. One advantage of using beam elements is that the beam axial and bending stresses can be easily extracted and compared to AISC (AISC Steel Construction Manual, 2005) or similar criteria.

Densities are adjusted so that compressor, gear and motor analytical model weights equal the weights on the outline drawing. Additionally, checks must be made to ensure that the center of gravity of the major equipment in the FEA model accurately represents the center of gravity on the outline drawing.

The lifting lugs should be modeled and a lifting evaluation of the entire base performed; however, the lifting lugs are always rated in a separate analysis where more detailed analytical models representing the plates, pipes, welds, and bolts associated with the lifting lug are used. Hand calculations and FEA are used to evaluate the lifting lug. The stress criteria (ASME BTH-1-2011, 4/7/12) must be satisfied for the lugs. The total package load plus the weight of the shipping box must not exceed the rated lifting lug load.

## DATA GATHERING

A significant amount of information is required for the analyses. Work on assembling this information is initiated when the order is procured and continues through the analysis



phase. For all FPSO projects, FEA load cases must be run with preliminary estimates of certain data as already discussed for the AVM stiffness values. Thermal growth calculations, final motor and gear drawings (including motor and gear rotor details) are typically obtained after the start of the analysis phase. The ship deck stiffness is typically not available until near the end of the analysis. Coupling designs (which affect the shaft end displacement criteria) are finalized during the analysis. Stress and displacements resulting from preliminary runs (which use preliminary data) provide important information on the sufficiency of the design and whether base design changes are required. The preliminary analysis runs also allow us to determine worst case load conditions (a significant effort). Near the end of the analysis phase when all of the final information is available, the worst case load conditions are rerun to ensure that the final stresses and displacements are acceptable. Typically, these final results do not deviate more than a few percent from the preliminary results; hence the value of starting the design and analysis with preliminary data is apparent.

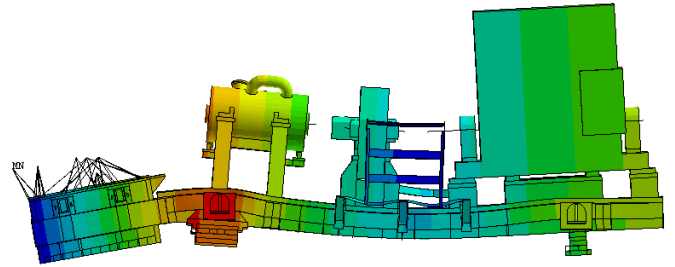
Typical data and information required for the analysis are as follows:

- Compressor, gear and motor rotor weights, and rotordynamic input, including bearing stiffness
- Hand calculations of compressor and motor side thermal growth
- Ship deck and AVM stiffness
- Maximum continuous parallel offset (MCPO) for high- and low-speed couplings
- Base and outline drawings
- Client specifications for wind loading and accelerations due to pitch and roll, and any special requirements on load cases or load case combinations
- Material properties and strengths
- Horsepower, speed and shutdown vibration
- Compressor flange load information

All the required information and sources are documented continuously in the process.

## LOADS, LOAD CASE REQUIREMENTS AND CRITERIA

The lift of the entire base package is analyzed by simulating the constraints from the chain at a 60-degree angle from the horizontal and applying the acceleration due to gravity to the base package. A resulting displacement plot for one base package is shown in Figure 32. The stress results on the base beams and plates and are evaluated per the criteria (ASME BTH-1-2011, 4/27/12). The lifting lugs and associated pipe, welds and bolts are evaluated separately using more detailed analytical models, as stated above.



**Figure 32.** Lifting evaluation of a base package

Occasionally, clients will provide compressor flange (nozzle) loads cases for evaluation. These typically include from five to 50 separate nozzle load combinations. If nozzle loads specific to the contract are not provided, the worst case combination of nozzle loads that satisfies the  $3Fr + Mr$  limit for each compressor nozzle and the  $2Fc + Mc$  limit for all nozzles (API 617, 2002) are determined. Each nozzle load (three translational loads and three moments) for each nozzle are run independently in the FEA. If the compressor has two nozzles, this is 12 runs. If the compressor has four nozzles, this is 24 runs. For each of these runs, the shaft end relative displacement between the compressor and high-speed gear shaft, and the shaft end relative displacement between the driver and low-speed gear shaft are determined. The FEA displacement results are input to the spreadsheet and linear elastic superposition is used to determine the shaft end relative displacement for any combination of nozzle loads. All possible loading combinations on all possible nozzles are evaluated to identify the case with the largest shaft end relative displacement. The nozzle load combinations that result in the highest shaft end relative displacements are used with other loads for the operational load case evaluations.

The normal operating load cases consider dead weight, acceleration from the FPSO vessel pitch, roll and heave, shutdown unbalance, torque, wind, and worst case nozzle loads. All of these loads (except for the dead loads) are run individually and the shaft end relative displacements are determined. Linear elastic superposition is again used to find the combination of loads that result in the highest shaft end relative displacement. The worst cases usually entail all loads acting in the same direction, but there may be exceptions. The worst case loads are determined based on shaft end displacement rather than on stress. Base package design changes are almost always due to shaft end displacement limitations rather than stress limitations. Once the worst case combination of loads is determined, the following cases are run:

1. Nozzle + acceleration + unbalance + torque + axial wind + dead loads
2. Nozzle + acceleration + unbalance + torque + lateral wind + dead loads
3. Nozzle + acceleration + unbalance + torque + axial



wind

- Nozzle + acceleration + unbalance + torque + lateral wind

Cases 1 and 2, which include dead loads, are used to evaluate stresses. The only difference in these cases is the wind direction (axial or lateral). Examples of stress results are shown in Figures 33 and 34. Typically bulk average stresses are low and well within the criteria stresses. Cases 3 and 4 are the same as Cases 1 and 2, respectively, except they do not include dead loads. Cases 3 and 4 are used to evaluate shaft end relative displacements. Note that dead loads should not be included when evaluating shaft end relative displacements, since the shafts are aligned in the dead load condition. The shaft end relative displacements must be within the coupling capability criteria, which is a prescribed percentage of the coupling maximum continuous parallel offset (MCPO) with an adjustment for thermal growth if needed. The percentage is more stringent for compressor to gear coupling because of the higher speed. Table 1 shows typical shaft end relative displacement results versus criteria. Since the base beams typically are modeled with shell elements as opposed to beam elements, beam axial stresses and bending moments cannot be easily extracted for comparison to criteria in AISC Steel Construction Manual, 2005. Therefore, a stress criterion was developed that limits bulk average stresses on the base beams and pedestals to a fraction of the yield strength that is consistent with AISC criteria.

For the transportation analyses, the X, Y and Z acceleration loads, dead loads, axial wind loads, and lateral wind loads are applied simultaneously in a combination that will result in the worst case stresses. The acceptable stress criteria are the same as that used for the operational load cases.

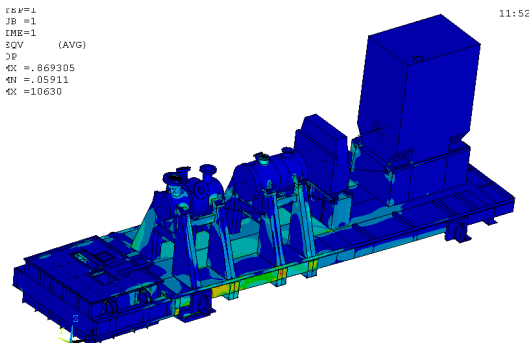


Figure 33. Von Mises stress contour of a base package under operational loads.

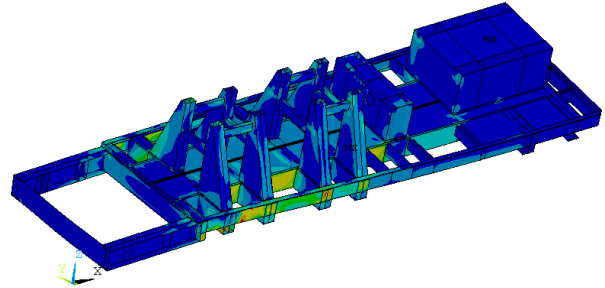


Figure 34. Von Mises stress contour of a base only.

Load Case	Shaft End Relative Displacements Calculated Using FEA, mm		Shaft End Relative Displacement Criteria, mm	
	Compressor to High Speed Gear	Motor to Low Speed Gear	Compressor to High Speed Gear	Motor to Low Speed Gear
Operational	0.605	0.572	1.369	1.016
Upset	0.536	0.564	3.594	1.524

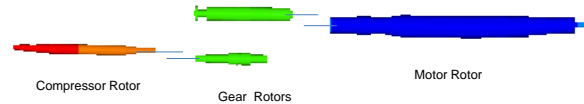


Table 1. Shaft end relative displacements calculated using FEA and compared with criteria.

A number of upset load cases may be required. These include:

- Motor short circuit torque
- FPSO survival (extreme) acceleration loading with survival lateral wind
- FPSO survival (extreme) acceleration loading with survival axial wind

For the survival cases, the shaft end relative deflection criteria is relaxed considerably since the equipment should be shut down during these extreme conditions. For all upset cases, the acceptable stress criteria are the same as that used for the operational load cases.

## BLAST ANALYSIS AND EVALUATION

Blast load analysis is often required for offshore. Blast loads may be applied as an equivalent static pressure, and blast load amplitudes from .08 bar to .8 bar have been requested. For any blast load amplitude, evaluations are performed for the longitudinal, transverse and vertical directions. Some permanent deformation of the base structural members is permissible provided it can be demonstrated that the base will not be driven into the deck. Therefore stresses in the bulk of the structural members should be below the minimum material yield stress, although some permanent residual deformation is



allowable, provided the ship deck is not affected. Figure 35 is a stress contour plot resulting from a vertical blast. Contours are set so that stress above the minimum yield strength is shown in gray. For this package only localized areas near the top of the lube oil console exceeded the minimum yield strength. The total loads on the AVMs resulting from the blast must not be greater than 3.0 times the loads used to design the AVMs. For the vertical blast case shown in Figure 35, the AVM loading was at most 2.7 times the AVM design load.

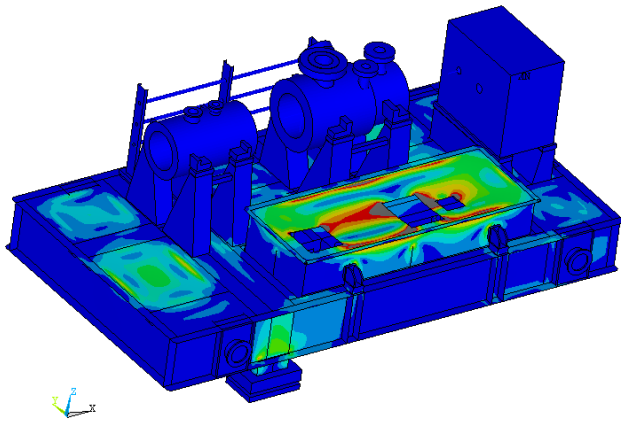


Figure 35. Von Mises stress contour resulting from vertical blast load.

### MODAL ANALYSIS AND EVALUATION

Frequencies and mode shapes are calculated through 120% of the compressor design speed. The analysis will typically identify hundreds of frequencies and associated mode shapes. Major modes (modes where the entire base moves) must be outside of the driver and compressor speed ranges by at least 20%. These major modes have high modal effective mass.

Tables 2 and 3 show results for a typical FPSO base package design. The motor and compressor run speeds are documented in Table 2, along with the corresponding frequencies within 20 percent of these speeds. For this job, 694 frequencies were calculated within the analysis speed range. Table 3 shows that 24 of these modes were lower than .8 times the motor run speed range. These 24 modes accounted for 99.7 percent, 99.9 percent and 99.9 percent of the total modal effective mass of all modes in the axial (longitudinal), lateral (athwart ships) and vertical directions, respectively. Therefore, the requirement for major modes to be out of the run speed range is satisfied. Mode 1 is shown in Figure 36. This mode, which shows rocking about the longitudinal axis, has the highest modal effective mass in the athwart ships direction. Mode 3 in Figure 37 shows both sliding of the base in the longitudinal direction and rocking about the athwart ship axis. This mode has the highest modal effective mass in the longitudinal direction. Figure 38 shows Mode 6,

which is associated with vertical motion of the entire base. Table 3 shows that modes 25 to 47 are within 20 percent of one times the motor speed. These modes only account for .30 percent, .03 percent and .07 percent of the total effective mass in the X, Y and Z directions. There are 48 modes within 20 percent of the two times the motor run speed range and 273 modes within 20 percent of one times the compressor run speed range. These modes account for a very low percentage of the total effective mass as shown in Table 3. Many of these higher modes are associated with the motion of a localized portion of the base; therefore, the effective mass associated with these modes is small.

Run Speed RPM		Frequencies within 20% of Run Speed Range, Hertz	
		Min	Max
1X Motor	1,783	23.8	35.7
2X Motor	3,566	47.5	71.3
1X Compressor	11,340	151.2	226.8

Table 2. Run speed ranges to be considered in modal and harmonic response analysis

Modes	X (Axial) Direction		Y (Lateral) Direction		Z (Vertical) Direction	
	Effective Mass in Range	Eff Mass in Range / Total Eff Mass %	Effective Mass in Range	Eff Mass in Range / Total Eff Mass %	Effective Mass in Range	Eff Mass in Range / Total Eff Mass %
1 to 24	652.012	99.67%	653.716	99.93%	653.394	99.88%
25 to 47	1.932	0.30%	0.217	0.03%	0.476	0.07%
48 to 70	0.146	0.02%	0.093	0.01%	0.101	0.02%
71 to 118	0.062	0.01%	0.057	0.01%	0.183	0.03%
119 to 340	0.025	0.00%	0.081	0.01%	0.013	0.00%
341 to 613	0.004	0.00%	0.008	0.00%	0.010	0.00%
614 to 694	0.001	0.00%	0.002	0.00%	0.001	0.00%
Totals	654.181	100.00%	654.174	100.00%	654.178	100.00%

Modes 25 to 47 are within 20% of 1X motor speed  
Modes 71 to 118 are within 20% of 2X motor speed  
Modes 341 to 613 are within 20% of 1X compressor speed

Table 3. Modal effective mass in run speed range and outside of run speed range.

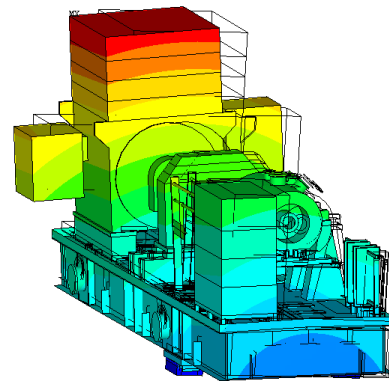
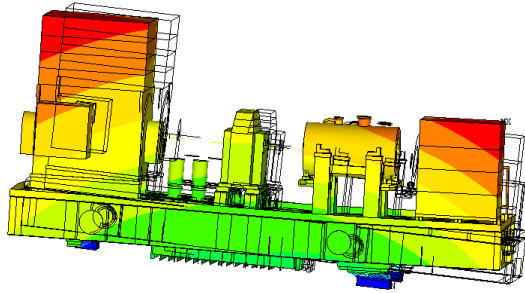
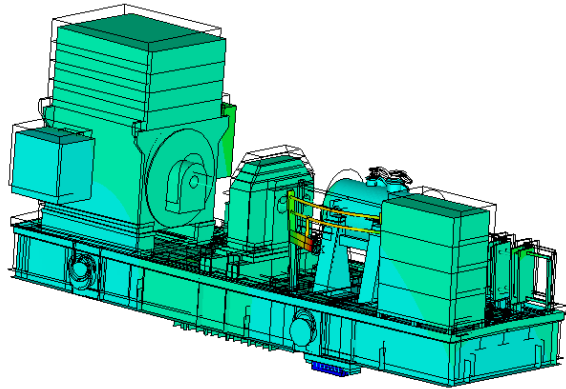


Figure 36. Primary rocking mode about longitudinal axis.



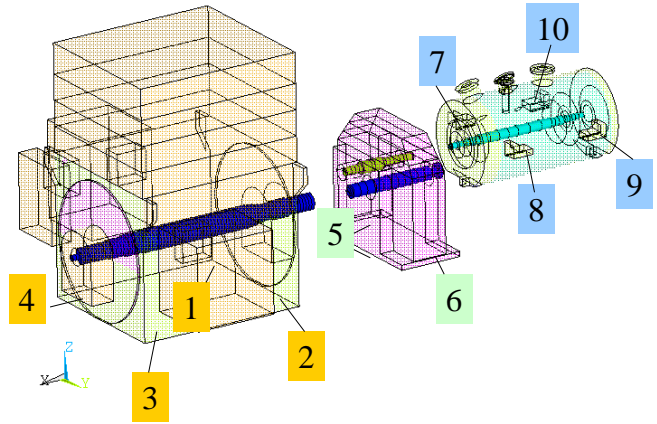
**Figure 37.** Primary rocking mode about athwart ship (lateral) axis.



**Figure 38.** Primary vertical mode with entire package moving vertically.

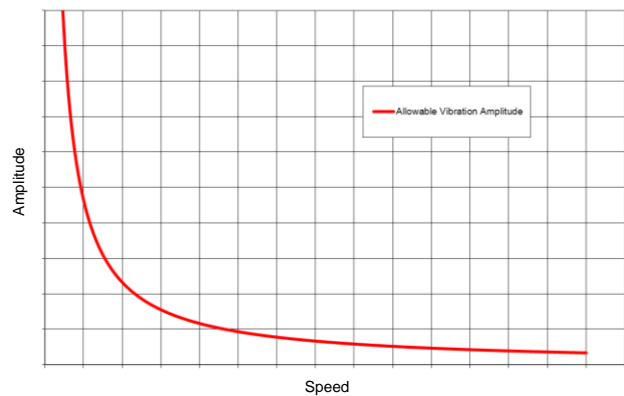
### EQUIPMENT VIBRATION AMPLITUDE CALCULATION AND ACCEPTANCE CRITERIA

A harmonic response analysis is performed to ensure that modes in the run speed range, although of small effective mass, do not result in unacceptable vibration at the feet of the major equipment. The typical locations monitored are shown in Figure 39. These include the four corners of the motor base, two locations at the base of the gear and the four compressor feet. Appropriate multiples of mid span unbalance per API are applied to the mid-span of the compressor, gear and driver rotor models. Both the real and imaginary portions of the loading are defined to simulate the rotating unbalance load on each rotor. The imaginary component has a 90° phase shift with respect to the real component.

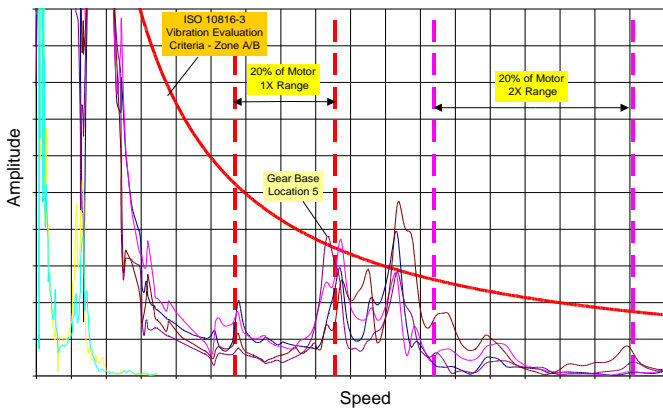


**Figure 39.** Location at base of major equipment where vibration amplitudes are calculated.

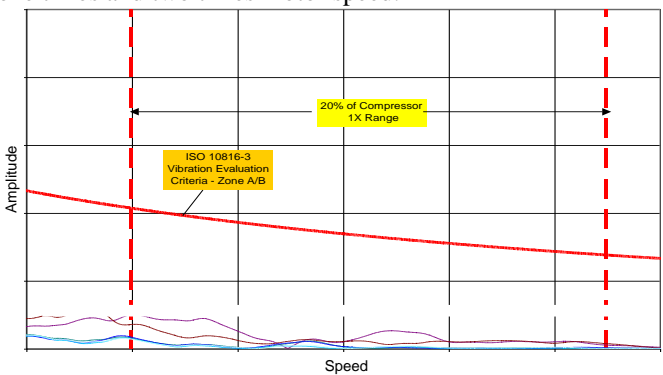
The allowable amplitude of vibration (Mechanical Vibration, May 15, 1998) is plotted versus speed in Figure 40. Typical plots of resulting amplitudes of vibration versus speed are shown in Figures 41 and 42. Figure 41 shows the results for one and two times the motor run speed range. One location at the base of the gear was marginally above the criteria line. This was judged to be acceptable because it was very close to the upper 20 percent of the range. Additionally, damping was not included, making the results conservative.



**Figure 40.** Allowable vibration amplitude



**Figure 41.** Calculated amplitude of vibration versus criteria for one times and two times motor speed.



**Figure 42.** Calculated amplitude of vibration versus criteria for one times compressor speed.

Figure 42 shows the results for one times the compressor run speed range. All amplitudes for all locations monitored were significantly below the criteria line. This further demonstrates that the 273 modes in this range are all insignificant.

## DESIGN CHANGES

When criteria are not met, plots of FEA model deformations, including animations of these displacements, are very helpful in determining where changes are required. These design changes are typically made during the analysis phase and rarely need to be made due to stress considerations. Multiple bases were modified as a result of shaft end relative displacement criteria. These modifications included:

- Swapping of AVMs to include two under the compressor
- Increased torque box and torque tube stiffness
- Welding of beams to the side of a torque box
- Cross-bracing of compressor to gear pedestals
- Cross-bracing of gear to motor pedestals
- Additional stiffening plates
- Thicker pedestal plates and gussets inside of pedestals

- More robust keel blocks
- Stiffening plates in base between compressor and gear
- Additional bracing of longer plates to reduce vibration
- Additional bracing on auxiliary equipment supports

The cross-bracing options are effective, but may not always be an option because of interference with other equipment. They could also present a tripping hazard.

For all design modifications, the FEA model is rerun with the design modifications included to verify that criteria are met. As three-point mount designs have been conducted for a number of years, the design changes identified as a result of analyses have decreased significantly. Lessons have been learned as to what changes are most effective, and many of the design changes have been carried over to new contracts. Using larger base wide flange beams instead of torque boxes or torque tube have been shown to be effective in increasing base stiffness. These add weight to the package, but can be a very attractive option. Using the larger beams may eliminate the need for other design changes. Additionally, since the larger wide flange beam designs do not need a torque box or torque tube, the lube oil console can be included under the base rather than on the end of the base, or they can eliminate the need for multiple torque tubes that would be needed to accommodate an in-base lube oil console. A shorter base package footprint is desirable on FPSOs where space is a premium. The lessons learned do not minimize the need for analysis on new contracts, especially as the base package design continues to improve and evolve.

## REDUCTION OF ANALYTICAL CYCLE TIME

FEA model development time has been shortened considerably. The largest time reduction has been in the shell element modeling of the wide flange beams, pedestals and plates. This was accomplished with more efficient extraction of the mid-plane thickness and edge connections with joining plates using the ANSYS Design Modeler program. The time required for data collection has been shortened through the list all of the data needed, which includes the source of the data. The time required to determine the worst case combination of nozzle loads and operational loads has been shortened due to the highly efficient linear elastic superposition calculation. These improvements and automations have reduced total analysis time by at least 40 percent.

## SUMMARY

Worldwide distribution of FPSOs and typical applications have been discussed. The three AVMs dampen the response and isolate the base package from the FPSO deck. Three base





ASIA TURBOMACHINERY & PUMP SYMPOSIUM  
SINGAPORE | 22 - 25 FEBRUARY 2016  
M A R I N A B A Y S A N D S

designs have been discussed. Torque box and torque tube designs provide torsional stiffness and result in lighter base packages. Larger I-beam designs are heavier, but provide higher torsional stiffness and allow for a shorter package by including the lube oil reservoir under the base. The shaft end relative displacement criteria have been shown to be more limiting than the stress criteria. Significant detail is included in the FEA models in order to accurately calculate the shaft end relative displacement. These details include more accurate modeling of the rotors, bearing connections, compressor pedestal sliding, and keel blocks. The importance of initiating the analysis while using preliminary data is emphasized as the base manufacture and analysis phases are conducted concurrently. Base modifications that are identified early in the manufacturing cycle are much easier to implement than those identified later. Improvements in data gathering, FEA model preparation and the automation of worst load case combinations have resulted in a 40 percent reduction in analysis time. The analytical models provide a valuable tool in assessing the suitability of three-point base package design for operation on FPSOs.

Measured in Situ," ISO 10816-3:1998(E), First Edition, May 15, 1998.

8. Steel Construction Manual, American Institute of Steel Construction (AISC) Inc. 13th Edition, 2005.

## ACKNOWLEDGEMENTS

The authors wish to thank Dresser-Rand for its support and permission to publish this paper, and also wish to thank Petrobras America Inc., Det Norske, Chevron, Stop-choc Limited, and Mr. James Sorokes of Dresser-Rand for their assistance.

## REFERENCES

1. "Axial & Centrifugal and Expander Compressors for Petroleum, Chemical and Gas Industry Services," American Petroleum Institute (AI) 617, 7th Edition, July 2002.
2. Daniel, et.al., Petrobras America Inc., "First Floating, Production Storage and Offloading Vessel in the U.S. Gulf of Mexico," 2013 Offshore Technology Conference, OTC 24112.
3. "Design of Below-the-Hook Lifting Devices," ASME BTH-1-2011, The American Society of Mechanical Engineers, 4/27/12.
4. Gisvold, K., The History of FPSOs, Det Norske Veritas, retrieved March 3, 2014 from, <http://www.tekna.no/ikbViewer/Content/740379/Gisvold.pdf>.
5. Mahoney, Christopher, "2013 Worldwide Survey of Floating Production, Storage and Offloading (FPSO) Units," Offshore Magazine, August 2013.
6. Mastrangelo, et.al., - Petrobras America Inc., "FPSOs in the Gulf of Mexico," retrieved March 3, 2014 from, <http://www.data.boem.gov/homepg/PDFs/Source%20Slide%20Show%20and%20Video-Audio%20Clips/3C03%20Mastrangelo%20Slide%20Show.pdf>.
7. Mechanical Vibration; Evaluation of Machine Vibration by Measurements on Non-Rotating Parts, Part 3: Industrial Machines with Nominal Power Above 15KW and Nominal Speeds Between 120 r/min and 15,000 r/min When