

**SCREENING POTATO GENOTYPES FOR ANTIOXIDANT  
ACTIVITY, IDENTIFICATION OF THE RESPONSIBLE  
COMPOUNDS, AND DIFFERENTIATING RUSSET NORKOTAH  
STRAINS USING AFLP AND MICROSATELLITE MARKER  
ANALYSIS**

A Dissertation

by

ANNA LOUISE HALE

Submitted to the Office of Graduate Studies of  
Texas A&M University  
in partial fulfillment of the requirements for the degree of

DOCTOR OF PHILOSOPHY

December 2003

Major Subject: Genetics

**SCREENING POTATO GENOTYPES FOR ANTIOXIDANT  
ACTIVITY, IDENTIFICATION OF THE RESPONSIBLE  
COMPOUNDS, AND DIFFERENTIATING RUSSET NORKOTAH  
STRAINS USING AFLP AND MICROSATELLITE MARKER  
ANALYSIS**

A Dissertation

by

ANNA LOUISE HALE

Submitted to Texas A&M University  
in partial fulfillment of the requirements  
for the degree of

DOCTOR OF PHILOSOPHY

Approved as to style and content by:

---

J. C. Miller, Jr  
(Chair of Committee)

---

Jim J. Giovannoni  
(Member)

---

Jeffrey D. Hart  
(Member)

---

R. Daniel Lineberger  
(Member)

---

Stephen King  
(Member)

---

Tim Davis  
(Head of Department)

---

Geoffrey M. Kapler  
(Chair of Genetics Faculty) December 2003

Major Subject: Genetics

## ABSTRACT

Screening Potato Genotypes for Antioxidant Activity, Identification of the Responsible Compounds, and Differentiating Russet Norkotah Strains Using AFLP and

Microsatellite Marker Analysis. (December 2003)

Anna Louise Hale, B.S., Texas A&M University

Chair of Advisory Committee: Dr. J. Creighton Miller, Jr.

Total antioxidant activity and total carotenoid levels were evaluated for more than 100 common potato (*Solanum tuberosum*, L.) cultivars grown in the United States, advanced breeding lines from several Western U.S. breeding programs, and 47 related, tuber-bearing species. An initial assessment of variability for antioxidant activity provided baseline information to be used for potential potato promotion and for the development of new varieties with greater human health benefits. Wide variability in antioxidant levels provided evidence of genetic control of this trait, indicating that it could be possible to breed for enhanced levels of antioxidant compounds in potato. Accessions, varieties, and advanced breeding lines identified in the broad screen as having high antioxidant activity and high total carotenoid levels, were fine screened via HPLC to determine specific phenolic and carotenoid compounds present in potato. The objective of the study was to identify parents for use in the Texas breeding program to develop potato varieties containing increased levels antioxidant compounds.

In the broad screen for total antioxidant activity, the 47 related, tuber-bearing species showed a wider range of variability than the cultivated varieties and breeding

lines. Based on the DPPH assay, antioxidant activity ranged from 103-648  $\mu\text{M}$  trolox equivalents in the cultivated varieties and advanced breeding lines, while that of the wild species was 42-892. HPLC analysis revealed that the phenolic content of the species, and their cultivated counterparts, was primarily composed of caffeic and chlorogenic acids. Other phenolics identified were p-coumaric acid, rutin hydrate, vanillic acid, epicatechin, t-cinnamic acid, gallic acid, and salicylic acid. The highest phenolic content discovered in the accessions was five-fold higher than the highest of the cultivated genotypes. Carotenoid analysis revealed lutein in the accessions, but the yellow-flesh breeding lines were much higher in carotenoids.

In addition to the work conducted on antioxidants, an attempt was made to separate intraclonal variants of the potato cultivar Russet Norkotah. Eleven microsatellite primers and 112 AFLP primer combinations failed to produce any reproducible polymorphisms. The inability to detect differences between the clones could be due to the tetraploid nature of the clones or epigenetic differences not detected by the procedures utilized in this study.

## ACKNOWLEDGMENTS

I would like to express my sincere thanks and appreciation to my committee chairman, Dr. J. Creighton Miller, Jr. for his patience and guidance during my years as a graduate student. Dr. Miller's enthusiasm for this research encouraged me to complete this project. He will always be remembered as a wonderful advisor, a great role model, and a good friend. Dr. Jeannie Miller, Creighton's wife, is a truly remarkable woman. Her assistance in editing everything I've written, including, presentations, abstracts, web pages, and this dissertation is greatly appreciated.

I would also like to thank my committee members for their unique contributions to this project. I have greatly admired Dr. Jim Giovannoni since our initial encounter. Jim has taught me a great deal about molecular genetics, but more importantly, he represents the type of professional that I strive to become some day. Despite being well known in the world of science, Jim never seems to forget about the little people. His patience, knowledge, and his willingness to serve on my committee, even after moving to New York, are greatly appreciated. I would like to thank Dr. Jeffrey Hart for his statistical help on a number of projects as well as his wonderful sense of humor. Dr. Hart's enthusiasm for this project when it was becoming routine for me, made it exciting once again. Dr. Daniel Lineberger, in addition to his scientific advice, taught me how to design web pages, and encouraged my artistic side. His novel approaches to problems and his ability to predict the "next big thing" are greatly admired. Steve King's

enthusiasm for this project, his advice, and his and willingness to join the committee on short notice are greatly appreciated.

In addition to my committee members, a number of other faculty members have had a significant impact on me during graduate school. Dr. Jerry Taylor, in addition to his help with quantitative genetics, was very supportive of me both in and out of the classroom. He is full of great advice and will always be remembered as a good friend. Dr. Jim Wild has encouraged me since my freshman year at A&M, and his trust in me is greatly appreciated.

I would like to express my appreciation to the people who I've worked with in Dr. Miller's lab including Doug Scheuring, and my fellow graduate students, Lavanya Reddivari, Tyann Blessington, and Ndambe Nzaramba. None of this would have been possible without our student workers Kristin Sikorski, Dean Whittaker, Pamela Cifra, Christine Johnson, Tori Meyer, Jenny DeMarko, and Mark Tietz.

I would like to extend my special thanks and love to my husband, Eric, my parents, and my grandfather, for their patience, love, understanding, and support through the years. Finally, I would like to thank the friends that I've met at Texas A&M (especially Ashlee McCaskill and Shanna Moore) for their support.

## TABLE OF CONTENTS

	Page
ABSTRACT.....	iii
ACKNOWLEDGMENTS.....	v
TABLE OF CONTENTS .....	vii
LIST OF FIGURES.....	xi
LIST OF TABLES.....	xiii
 CHAPTER	
I INTRODUCTION.....	1
Statement of the Problem .....	3
II LITERATURE REVIEW .....	4
Introduction .....	4
History of the Potato .....	4
Potato Production in Texas .....	8
Nutritional Value of the Potato .....	11
Part #1. Screening Potato Genotypes for Antioxidant Activity and Identification of the Responsible Compounds .....	14
Micronutrients and Their Importance to Human Health..	14
Antioxidants .....	15
Phenolics and Polyphenols.....	19
Carotenoids.....	23
Antioxidants in Potatoes.....	31
Phenolics in Potatoes.....	32
Carotenoids in Potatoes .....	38

CHAPTER	Page
Part #2 - Differentiating 7 Russet Norkotah Strains Using AFLP Marker Analysis .....	49
Karyological and Isozyme Analyses .....	50
Restriction Fragment Length Polymorphisms (RFLP) ....	51
Randomly Amplified Polymorphic DNA (RAPD) .....	52
Amplified Fragment Length Polymorphisms (AFLPs)....	53
Microsatellites .....	56
 III	
INTRASPECIFIC VARIABILITY FOR ANTIOXIDANT ACTIVITY IN POTATO ( <i>S. TUBEROSUM</i> L.) .....	60
Introduction .....	60
Materials and Methods .....	62
Plant Materials.....	62
Extraction of Antioxidants .....	66
DPPH Assay for Total Antioxidant Activity.....	68
HPLC Analysis of Phenolic Compounds .....	70
Broad Screen for Carotenoid Content .....	72
HPLC Analysis for Carotenoid Compounds.....	72
Results and Discussion.....	74
DPPH Assay for Total Antioxidant Activity.....	74
HPLC Analysis of Phenolic Compounds .....	89
Broad Screen for Carotenoid Content .....	92
HPLC Analysis of Carotenoid Compounds .....	105
 IV	
INTERSPECIFIC VARIABILITY FOR ANTIOXIDANT ACTIVITY AMONG <i>SOLANUM</i> SPECIES .....	117
Introduction .....	117
Materials and Methods .....	119
Plant Materials.....	119
Extraction of Antioxidants .....	125
DPPH Assay for Total Antioxidant Activity.....	129
HPLC Analysis of Phenolic Compounds .....	130
Broad Screen for Carotenoid Content .....	131
HPLC Analysis for Carotenoid Compounds.....	132
Results and Discussion.....	133
DPPH Assay for Total Antioxidant Activity.....	134
HPLC Analysis of Phenolic Compounds .....	148
Broad Screen for Carotenoid Content .....	158
HPLC Analysis of Carotenoid Compounds .....	169



CHAPTER	Page
V	DIFFERENTIATING SEVEN RUSSET NORKOTAH STRAINS USING AFLP AND MICROSATELLITE MARKER ANALYSIS .....178
	Introduction ..... 178
	Materials and Methods ..... 180
	DNA Isolation and Concentration ..... 181
	AFLP Analysis I – Visualized via Silver Staining ..... 181
	AFLP Analysis II – LiCOR Analysis ..... 185
	Microsatellite Analysis ..... 189
	Results and Discussion ..... 191
	AFLP Analysis ..... 191
	Discussion ..... 194
VI	CONCLUSIONS ..... 201
VII	SUMMARY AND RECOMMENDATIONS ..... 210
	LITERATURE CITED ..... 212
	APPENDICES ..... 225
	APPENDIX A ..... 226
	APPENDIX B ..... 228
	APPENDIX C ..... 229
	APPENDIX D ..... 230
	APPENDIX E ..... 231
	APPENDIX F ..... 232
	APPENDIX G ..... 234
	APPENDIX H ..... 235
	APPENDIX I ..... 236

	Page
APPENDIX J.....	237
APPENDIX K.....	238
APPENDIX L.....	239
APPENDIX M.....	240
APPENDIX N.....	241
APPENDIX O.....	242
APPENDIX P.....	243
APPENDIX Q.....	244
VITA.....	245

## LIST OF FIGURES

FIGURE	Page
2-1	Role of free radicals in disease..... . 17
2-2	Basic structure of the flavonoids, flavones, flavanones and isoflavones ..... . 20
3-1	Diagram of extraction procedure for carotenoids and phenolics ..... . 69
3-2	Distribution of antioxidant activities for genotypes analyzed in Field Day Trial 2000 ..... . 77
3-3	Variation in antioxidant activity among Russet Norkotah and its intraclonal variants, Field Day Trial 2000 ..... . 78
3-4	Comparison of antioxidant activity from tubers grown in Springlake and Dalhart during the 2000 growing season..... . 80
3-5	Antioxidant activities of genotypes analyzed in 2001 ..... . 85
3-6	Comparison of Field Day data for antioxidant activity across 2 growing seasons reveals a significant interaction between year and genotype..... . 86
3-7	A representative chromatogram of the separation of phenolics in Field Day Trial 2001 samples via HPLC ..... . 92
3-8	Total carotenoid content of genotypes harvested in 2000 ..... . 96
3-9	Comparison of total carotenoid content of Russet Norkotah and its intraclonal variants ..... . 97
3-10	The carotenoid content of genotypes harvested in Field Day Trial 2001 ..... . 101
3-11	Comparison of total carotenoid content for Field Day Trial 2000 and 2001..... . 103
3-12	Chromatogram showing the separation of carotenoid components via HPLC ..... . 105

FIGURE	Page
3-13 Carotenoid chromatogram for ATX82539-4Ru .....	107
3-14 Carotenoid HPLC chromatogram for BTX1749-2Ru/Y grown in Field Day Trial 2001 .....	108
3-15 The relative order of the genotypes is quite consistant between 2001 and 2003, but less consistant between 2000 and 2003 .....	111
3-16 Total carotenoid content of tubers grown in Field Day Trial 2000, 2001, and 2003 .....	112
4-1 Diagram of extraction procedure for carotenoids and phenolics.....	128
4-2 Distribution of accessions analyzed in Bamberg 1 group.....	136
4-3 A typical chromatogram of phenolic separation of the wild species.....	153
4-4 Chromatogram showing the separation of carotenoid componenets via HPLC .....	170
4-5 A representative HPLC chromatogram of carotenoid samples run from Bamberg 1 (PI 458374).....	172
5-1 Diagram of the AFLP procedure using a single primer pair.....	184
5-2 A picture of a representative LI-COR gel with 4 different MseI/PstI primer pairs.....	193
5-3 A typical microsatellite gel depicting differences between ATX85404-8W and Russet Norkotah intraclonal variants.....	195
5-4 Russet Norkotah and clonal selections in the 1999 Arizona nursery.....	197

## LIST OF TABLES

TABLE	Page
2-1	A comparison of different levels of carotenoids detected by various authors ..... 45
3-1	Genotypes grown in 2000, which were used in the antioxidant analysis ..... 64
3-2	Genotypes grown in the 2001 Field Day Trial, which were used in the antioxidant analysis ..... 65
3-3	Genotypes grown in the 2000 and 2001 Field Day Trials, which were used in the antioxidant analysis for comparison of location ..... 66
3-4	Antioxidant activities of tubers grown in 2000 ..... 76
3-5	ANOVA table for Field Day Trial 2000 samples ..... 77
3-6	Antioxidant activity of 7 different brands of chips ranked by DPPH assay ..... 81
3-7	Antioxidant activities of 18 different vegetables ranked by the DPPH assay ..... 82
3-8	Antioxidant activity of tubers grown in 2001 ..... 84
3-9	ANOVA table for comparison of antioxidant activity of tubers grown in 2000 and 2001 ..... 87
3-10	Comparison of antioxidant activities from Field Day Trials 2000 and 2001 ..... 88
3-11	Phenolic compounds identified via HPLC in 2001 Field Day Trial samples ..... 91
3-12	Carotenoid content of genotypes analyzed from the 2000 Field Day Trial ..... 94

FIGURE	Page
3-13	Carotenoid content of genotypes analyzed from the 2001 Field Day Trial ..... 99
3-14	ANOVA table for comparison of total carotenoid content of tubers grown in 2000 and 2001 ..... 103
3-15	Comparison of total carotenoid content from Field Day Trial 2000 and Field Day Trial 2001 ..... 104
3-16	Comparison of Field Day Trial 2003 samples with Field Day Trials 2000 and 2001 ..... 110
3-17	HPLC results of Field Day Trial 2003 samples (processed, extracted and analyzed in a single week) ..... 113
4-1	Mixed populations obtained from the Inter-Regional Potato Introduction Station, Sturgeon Bay, WI (Bamberg 1) ..... 120
4-2	Mixed populations obtained from the Inter-Regional Potato Introduction Station, Sturgeon Bay, WI (Bamberg 2) ..... 121
4-3	Accessions obtained from the Inter-Regional Potato Introduction Station, Sturgeon Bay, WI in April 2002 (Bamberg 02)..... 122
4-4	<i>S. jamesii</i> accessions obtained from the Inter-Regional Potato Introduction Station, Sturgeon Bay, WI, in November 2001 ( <i>Jamesii</i> ) ..... 125
4-5	Antioxidant activities of Bamberg 1 accessions ..... 137
4-6	Antioxidant activities of Bamberg 2 accessions ..... 139
4-7	Antioxidant activities of Bamberg 02 accessions ..... 141
4-8	HPLC phenolic results for Bamberg 2 ..... 150
4-9	Mean separation for levels of chlorogenic acid contained in Bamberg 2 ..... 151
4-10	Mean separation of levels of caffeic acid contained in Bamberg 2 ..... 152

FIGURE	Page
4-11 HPLC phenolic results for Bamberg 02 .....	156
4-12 HPLC phenolic results for <i>jamesii</i> samples .....	158
4-13 Carotenoid content of accessions analyzed from Bamberg 1 .....	160
4-14 Carotenoid content of accessions analyzed from Bamberg 2 .....	162
4-15 Carotenoid content of accessions analyzed from Bamberg 02 .....	164
4-16 HPLC carotenoid results for Bamberg 1 .....	171
4-17 HPLC carotenoid results for Bamberg 1 based on retention time only .....	172
4-18 Accessions analyzed by HPLC for carotenoid content from Bamberg 2 .....	173
4-19 Accessions analyzed by HPLC for carotenoid content from Bamberg 02 .....	174
4-20 HPLC carotenoid results for Bamberg 1 based on retention time only .....	175
4-21 Promising accessions for future breeding projects aimed at increasing antioxidant activity and phenolic levels in potato .....	177
5-1 Primer sequences for adapters, pre-amplification primers, and selective amplification primers for AFLP Analysis System I .....	183
5-2 Primer sequences for adapters, pre amplification primers, and selective amplification primers for LI-COR.....	188
5-3 Primer sequences for microsatellite primers used in this study .....	190

## CHAPTER I

### INTRODUCTION

Potato is the leading vegetable crop in the U.S. and the 4<sup>th</sup> most important food crop worldwide. It is grown in most areas of the world, with the largest production in China, followed by the Russian Federation, India, Poland, and the United States. The annual potato crop in the U.S. is valued at an estimated \$2,933,853,000, and the industry provides for the employment of thousands (National Potato Council 2003).

Not only is potato an important crop on a worldwide scale, it is also an important crop to Texas. Potatoes are grown in most regions of the state, with an annual state farm-gate value of over \$50 million from about 20,000 acres (National Potato Council 2003). With a summer harvest of 3,120,000 cwt and a sales value of over \$30 million, Texas produces the highest yield/acre in the U.S. summer crop. Due in great part to the work conducted by the Texas Potato Variety Development Program, yields in Texas have increased from less than 200cwt/acre in the 1970s when the program began, to 400cwt/acre in 2002.

The Texas Potato Variety Development Program has a growing interest in developing intracloonal variants, which exceed the parent variety in important agronomic traits. Among the most recent and promising genotypes developed through the program are six intracloonal variants of the potato cultivar Russet Norkotah (TXNS102, TXNS112, TXNS223, TXNS249, TXNS278, TXNS296).

---

This dissertation follows the style and format of the American Journal of Potato Research.



On both a state and national scale, the acreage of these intracloonal variants is rising. In 1999, 38% of the Russet Norkotah acreage entered into seed certification was to three of these five strains and two from the Colorado program (National Potato Council 2000), and by 2002, over half (52%) (National Potato Council 2003). TXNS 112, TXNS 223, and TXNS 278 have been granted Plant Variety Protection (PVP), while it is pending for TXNS296.

Potato tubers are rich in high-quality proteins, vitamins, minerals, and trace elements (International Potato Center 1984). Potatoes provide an excellent source of lysine (Freidman 1996), making them superior to cereal proteins, which lack this important amino acid. In addition to high quality proteins, potatoes contain substantial levels of vitamins and minerals, including vitamins C, and B (Kolasa 1993; International Potato Center 1984; Ahmad and Kamal 1980; Niederhauser 1993 ). Furthermore, there is preliminary evidence to suggest that potatoes contain significant levels of important antioxidants, including phenolic acids, flavonoids, and carotenoids, among others (Al-Saikhan *et al.* 1995; Al-Saikhan 2000; Arai *et al.* 2000; Gazzani *et al.* 1998; Lachman *et al.* 2000; Yamamoto *et al.* 1997; Dao and Freidman 1992; Freidman 1997). Unlike crops such as blueberries, potatoes have not been considered among foods important for their antioxidant content. This is unfortunate, considering the average per capita consumption of potatoes in the U.S. is about 137 pounds (National Potato Council 2003), while that of blueberries stands at 13.9 ounces (North American Blueberry Council 2003).

## Statement of the Problem

Potatoes have been found to contain significant levels of antioxidant compounds; however, previous studies have concentrated on a limited number of genotypes. The potential to increase antioxidants in potato, particularly phenolics, through breeding efforts has not been extensively investigated. Variation in antioxidant activity, as well as phenolic and carotenoid content, has not been determined for a wide range of genotypes. Furthermore, little is known about the antioxidant components contained in wild *Solanum* species. Since antioxidants are plant defense compounds, it is likely that, due to natural selection, wild species contain higher levels of these compounds than do cultivated varieties. Wild germplasm could serve as a source of important health-benefiting compounds in the widely consumed potato. Identification of genotypes high in antioxidant compounds is necessary to select parents for use in the Texas Potato Variety Development program. The long-range objective of the program in relation to this project is to develop potato varieties that can be promoted to the public at large as a vector for antioxidant consumption.

Russet Norkotah and its intracloonal variants have become an important part of the U.S. potato industry. Granting of PVP to the additional promising subclones is a major objective of the Texas Potato Variety Development Program. Molecular markers differentiating the clones from one another could be a persuading factor to the granting of PVP. Microsatellites and AFLPs have been used to fingerprint potato cultivars in the past, and could potentially produce markers which indicate genetic differences exist among the clones.

## CHAPTER II

### LITERATURE REVIEW

#### Introduction

##### *History of the Potato*

*Solanum tuberosum*, the cultivated potato, is known to many in the modern world as the “Irish Potato”. This, however, is a misnomer considering the crop is indigenous to the central Andean area of South America, and is not an old world crop (Ahmad and Kamal 1980). Evidence confirming this origin is the many wild relatives still growing today in this area of the world. Over 230 tuber-bearing wild relatives of potato have been identified (Zuckerman 1998).

Potato was established as a crop plant in the highlands of Peru and Bolivia well before 200 AD. Cultivation of the land through terracing and irrigation was developed, but it is not known how long it took the potato to be accepted as a staple crop in the area. It is known, however, that potatoes alone were capable of sustaining civilization high in the Andean mountains because grain did not flourish at these altitudes. The tubers of the frost resistant cultivars were exposed to the cold night temperatures of the region and subsequently processed into what the Spaniards termed *chuno*. This dried potato product sustained life even in times of drought, and has been credited as being critical in the development of Andean civilization (McNeill, 1999).

The crop spread northward to Columbia and Ecuador and southward to Argentina. By the time the Europeans arrived in the new world, cultivated potatoes were

established in the Northern half of the Andes and in Southern Chile. It is generally believed that the Spaniards brought the potato from South America to the old world, (Corell 1962; Ahmad and Kamal 1980). The earliest records of potato in the old world are those of a hospital buying potatoes for food in Seville, Spain in 1573 (Brown 1993). The year of introduction to Spain is thought to be between 1570 and 1580. The potato was brought to England around 1586, and by 1588, it was an established garden vegetable in Italy (Estabrook 1988).

Due to its resemblance to a truffle, herbalists in sixteenth century Europe called it by this name for a time. It took a long time for the potato to be accepted as an important part of the diet in Europe, due in part to its similarity to the nightshade, which was known to be poisonous. Others resisted the crop's acceptance because the phallic shape of the tuber caused it to be labeled as an aphrodisiac, casting shame upon anyone who showed interest in it. Furthermore, due to the appearance of the skin, it was suspected of causing leprosy (Brown 1993). The upper-class population at the time deemed potato an inferior dish suitable only for those who could not afford something better (Niederhauser 1993).

Folklore indicates that potatoes reached Ireland as a result of a shipwreck off the coast of Galway around 1588 (Estabrook, 1988). It was in Ireland where potato gained notoriety due to its great nutritional quality and the lack of other food in the country at the time (Ahmad and Kamal 1980). Ireland of the 18<sup>th</sup> century was predominantly composed of lower class tenants living on land owned by English landlords. These poor farmers were expected to produce agricultural commodities such as meat and grains in

return for their rent on the land. Potato was grown in poor soils not being used by the landlords for other crops, yet it yielded enough food to feed the household (Brown 1993). According to McNeill (1999), a single acre of potatoes and the milk of a single cow was enough to feed an entire family, and this diet, however monotonous, was nutritionally adequate to sustain a healthy rural population. By the end of the 18<sup>th</sup> century, potato was the chief food of the country and consumption grew to greater than 3kg per capita per day, and has been credited for the population explosion in Ireland at the time. By 1710, this old world crop became known as the “Irish Potato.” In 1845 and 1846 the potato crop in Ireland failed due to its narrow genetic base and a virtual monoculture of the variety Lumper (Brown 1993). Lumper was susceptible to late blight caused by *Phytophthora infestans*, and devastation caused by this fungus resulted in a great famine and the death of 12.5% of the Irish population and the emigration of another 20%.

Potatoes were not only an important crop for Ireland in the late 18<sup>th</sup> century. By this time, France had identified potato as a famine food that produced modest yields even when other crops failed (Brown 1993). It was promoted a great deal by Antoine-Augustin Parmentier’s essay, “Research on Nourishing Vegetables to Substitute for the Usual Foods During Famines,” in which he promoted the adoption of potato as a necessary staple food in France. One reason potato was finally able to find a niche in Europe was because of its ability to produce at least a small crop in the face of adversity. Since tuber seed is relatively large and the initial growing phase of the plant is vigorous, even under severely adverse conditions, the crop was able to re-emerge from new

sprouts. Furthermore, production on marginal soils was greater than that for either wheat or barley. In a time of constant warfare, the subterranean location of the crop was important because it was out of sight to enemy armies. As a result, they were not burned or stolen by the opposing troops. Perhaps just as important was its ease of preparation and its ability to “form flour without a mill and bread without an oven, and at all seasons of the year an agreeable and wholesome dish, unaided by expensive and injurious condiments” (Brown 1993).

There is some confusion as to when and from where the potato reached Colonial North America. It is said to have arrived in Bermuda as early as 1613, and then reached the mainland, probably Canada, by 1621. It is also said to have reached Canada by way of Britain in 1621 (Estabrook 1988). This, however, is disputed because the first hard evidence of American colonial potato growing is 1685. These potatoes presumably arrived from Northern Ireland (Zuckerman 1998).

In 1851, the Reverend Chauncey Goodrich began breeding late blight resistant cultivars by crossing common varieties with potato clones from South America. After many years of work, he discarded all but a few clones believing his breeding efforts had been a failure. In fact, his work has had tremendous bearing on the creation of modern cultivars due to his development of ‘Early Rose,’ an ancestor to more than 400 North American and European varieties, including Russet Burbank (Brown 1993).

In 1925, the Soviet scientist, N. Vavilov began collecting wild species and cultivars of potato (Brown 1993). His work and that of others led to the establishment of

germplasm banks in Europe and the U.S. where germplasm is made available to breeders as a source of resistance to various pests, pathogens, and abiotic stresses.

Today potato is the leading vegetable crop in the U.S. and the 4<sup>th</sup> most important food crop worldwide. Potato is grown in most areas of the world, with the largest production in China, followed by the Russian Federation, India, Poland, and the United States. The annual potato crop in the U.S. is valued at an estimated \$2,933,853,000, and the industry provides for the employment of thousands (National Potato Council 2003).

### ***Potato Production in Texas***

Potatoes are grown in most regions of Texas with a state value of over \$50 million from about 20,000 acres (National Potato Council 2003). Texas has potatoes in the ground 11 months out of the year, but the summer crop is the most economically important. Planting of the summer crop begins on the Rolling Plains in mid February, and continues into April on the High Plains. The crop is harvested beginning in the Rolling Plains in early June, and is completed with the harvest of the Dalhart crop in late September through early October. With a summer harvest of 3,120,000 cwt and a sales value of over \$30 million, Texas produces the most pounds of potatoes in a U.S. summer crop. Due in great part to the work conducted by the Texas Potato Variety Development Program, yields in Texas have increased from less than 200cwt/acre in the 1970s when the program began, to 400cwt/acre in 2002. These are the highest summer crop yields in the nation, with an average price of \$10.30/cwt for the year. States with the largest production of potatoes harvest their crops in September. By August, when

Texas potatoes are harvested, stores are running low, particularly on fresh market potatoes. Thus the high value of the summer crop is greatly due to the marketing window created by the ability of Texas growers to plant and harvest earlier than the rest of the country.

Although the summer crop is economically the most important, the spring crop should not be discounted. Planting of the spring crop begins in the Rio Grande Valley in early December, followed by the Winter Garden in mid January. These crops are harvested in April and May, and account for about 36% of Texas potato production. While the value of the spring crop, at \$9.15/cwt, does not command as high a market price as does the summer crop, it is still considerably higher than the U.S. yearly average price of \$6.60/cwt. The total production of the spring crop is 2,070,000cwt, and it has a production value of approximately \$16 million (National Potato Council 2002).

Types of potatoes grown in Texas include russet, white and red skinned varieties as well as an increasing number of colored flesh specialty varieties. Virtually the entire russet acreage in Texas is planted to strains of the potato cultivar Russet Norkotah selected by the Texas Potato Variety Development program. These include TXNS112, TXNS296, TXNS278, and TXNS223. It has been said that, without these strains, russet potato production on the Texas High Plains would be a thing of the past. Atlantic is the most popular white skinned variety grown in the state, along with a number of proprietary Frito Lay varieties, and Red LaSoda and Viking are the primary red skinned varieties. Yukon Gold is a yellow flesh variety that grows well in Texas, and in the past few years its acreage has increased dramatically. This is due, in part, to the growing



health consciousness of the American public, and the high levels of carotenoids (yellow pigmented cancer fighting compounds) in this variety. Another “healthy” variety, All Blue, was grown as a novelty variety on the High Plains last year at “Springlake Potato Sales, Inc.” All Blue has dark purple skin and flesh, and is high in anthocyanins (red and blue pigmented antioxidants). While this variety, to date, has only been grown on a small scale, as the public becomes more aware of the health benefits associated with anthocyanins and more used to the idea of eating purple potatoes, acreage and consumption of this variety are expected to increase.

While most commercial potato companies are in the northern U.S. and Canada, there are a number of major potato producers with interests in Texas. Perhaps most notable among these companies is Plano based Frito-Lay. Frito-Lay is the nation’s leading snack food company and processes over 5 billion pounds of potatoes per year. Many of these are provided by contract growers in Texas. One of the largest growers in Texas, CSS Farms, is the country’s largest supplier of raw product to Frito-Lay. McCain Foods, the largest exporter of frozen potato products in the world, has an increased interest in Texas as well. They recently teamed with Texas A&M to conduct proprietary trials in South Texas, and contributed financially to the state’s potato breeding program. Though there is increasing interest from processors in the state, only 30 percent of the state’s crop is used in processing. The Texas crop is used primarily for fresh market sales, and Farming Technology is the major distributor of these fresh-market potatoes. Farming Technology, a Houston based company, distributes the popular “Mountain King” potatoes. Mountain King has grown due in part to imaginative marketing

strategies. Potatoes that were previously culled due to size have been re-packaged to form attractive new products. These include “Petite Cooking Potatoes” as well as “Jumbo” potatoes.

### ***Nutritional Value of the Potato***

The worldwide acceptance of potato has depended in very small part on its nutritional quality, which is frequently overlooked by an uninformed public. Potato is rich in high-quality proteins, vitamins, minerals, and trace elements and has a high food value on a dry matter basis (International Potato Center 1984). Furthermore, potato produces a high proportion of edible biomass, with the tubers 100% edible and the foliage and roots excellent as fodder or silage for livestock (Neiderhauser 1993). In addition, the potato produces a greater amount of food per acre than either wheat or rice, and produces more yield per unit time (Ahmad and Kamal 1980; Niederhauser 1993). One acre of potato provides the annual energy and protein needs for over 10 people (Zuckerman 1998).

*Protein* - On a dry matter basis, potato contains less protein than wheat or rice, but on a cooked basis, it is comparable to these cereal crops and twice that of the sweet potato and cassava (International Potato Center 1984). Furthermore, the ratio of protein to carbohydrate is higher in potatoes than in cereals and other roots and tubers (Niederhauser 1993). Only about 50% of the total nitrogen of potatoes is contained in proteins, with the remaining 50% as free amino acids (15%) and other compounds (35%). On the basis of amino acid composition, the calculated protein quality is about

70% that of whole egg protein. Potatoes provide an excellent source of lysine, and human feeding trials indicate that potato proteins are of a very high quality (Friedman, 1996). Furthermore, potato protein is superior to cereal protein because it contains substantially more of the essential amino acids, with the exception of histadine. In other words, the amino acid content is better balanced than those of the cereals and the protein more comparable to that of animals. On a per hectare basis, potato can produce more energy and utilizable protein than any other food crop (Ahmad and Kamal 1980; Niederhauser 1993).

*Vitamins* - In addition to protein, potato is a good source of vitamins, minerals, and trace elements important to human health. Perhaps best known of these is the high content of vitamin C, especially when compared to the complete lack of this vitamin in rice and wheat. The vitamin C content of potato is comparable to mango and pomegranate, and more than half as high as that of tomato, orange and grapefruit (Ahmad and Kamal 1980). According to Ahmad and Kamal, (1980), 60% of an adult's daily requirement of about 25mg of vitamin C can be met by the ingestion of 100g of freshly harvested and cooked potato. Based on the new nutritional labeling using values provided by the FDA in 1992, a medium potato (1/3 lb) provides 50% of the RDA of vitamin C for adults (Kolasa 1993). Although there is considerable loss of vitamin C during storage, potatoes contribute an appreciable amount of this important vitamin in the human diet.

Potato is also rich in B vitamins, including thiamin (B<sub>1</sub>), riboflavin (B<sub>2</sub>), pyridoxine (B<sub>5</sub>), and nicotinic acid (B<sub>6</sub>). Since the B vitamins are water soluble, some of

them may be leached out during boiling (Ahmad and Kamal 1980). It was found that a fourth of thiamin, but no nicotinic acid was lost during the boiling process. Potato is the richest source of nicotinic acid among all principal food crops and is much higher than rice in thiamin (Ahmad and Kamal 1980). The production per hectare of total vitamins, including as vitamin C, is higher in the potato than in any other staple food crop (Niederhauser 1993). Furthermore, 60-90% of the B vitamins along with other nutrients found in wheat are lost during milling of white flour, making it necessary to fortify flour after processing (Willett 1994). While the B vitamins are replaced by fortifications, other lost nutrients may be nutritionally critical for persons with otherwise marginal intakes. Since much of the intake of wheat is in the form of milled flour, the importance of potato as a source of B vitamins is magnified. According to the National Potato Board, 1 medium potato provides 8% of the RDA for thiamin, 20% of the RDA for niacin, and 15% of the RDA for B<sub>6</sub>. Potatoes, excluding French fries, are the third largest source of Vitamin B<sub>6</sub> for adults ages 19-74, and fried potato products rank 10<sup>th</sup>. Together, they provide 9.2% of the vitamin B<sub>6</sub> consumed by adults (Kolasa 1993).

Although it is not considered a significant source of vitamin A in the diet, potato contains small quantities of this vitamin (Ahmad and Kamal 1980). This vitamin is found to be completely lacking in both wheat and rice, however. Pro-vitamin A includes carotenes such as alpha, beta, and gamma carotene and cryptoxanthin. Other carotenoids are found in potato in the form of pigments.

*Pigments* - Other pigments include anthocyanins, flavines, chlorophyll, porphyrin, and flavones. Levels of these pigments, as well as vitamin A, vary among varieties (Ahmad and Kamal 1980).

*Minerals* - Minerals found in potato include potassium, phosphorus, magnesium, sulfur, chlorine, calcium, iron, silicon, zinc, boron, bromine, aluminum, sodium manganese, iodine, fluorine, copper, cobalt, arsenic, lithium, molybdenum and nickel. Although some of these minerals are essential, some are found due to chance presence in the soil in which the tubers were grown. Found in large quantities are potassium, phosphorus, magnesium, sulfur, chlorine, calcium, silicon, iron and zinc. Of these, only calcium, phosphorus, and iron are considered important from a dietary viewpoint (Ahmad and Kamal 1980). Potatoes provide, per one-third pound serving, the following U.S. RDA: 8% of phosphorus, magnesium, copper and iron, 2% of zinc, 15% of iodine, 10% of calcium, and 750mg of potassium (Kolasa 1993).

## **Part #1. Screening Potato Genotypes for Antioxidant Activity and Identification of the Responsible Compounds**

### ***Micronutrients and Their Importance to Human Health***

Much research has been conducted on the benefits of various phytochemicals in many fruits and vegetables and their significant impact on human health. The importance of phytochemicals, including antioxidants, in tying up free radicals and thus fighting deadly diseases including cancer, stroke, and heart related health problems is

now recognized. A number of classes of chemicals including polyphenols (flavonoids, flavanols, flavones, and isoflavones), carotenoids (carotenes, chlorophylls, exopoxycarotenes, xanthophylls, etc.) and vitamins and minerals have been linked to the reduction and prevention of various diseases.

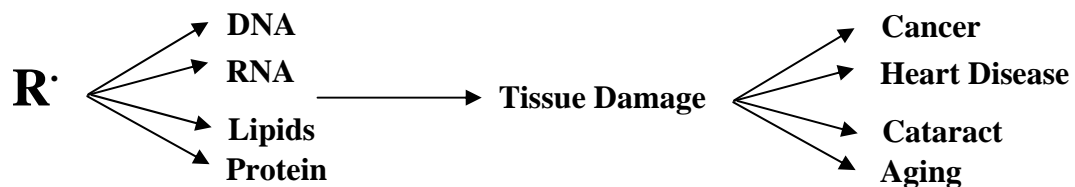
### ***Antioxidants***

Antioxidant behavior has been well documented for flavonoids, and other related polyphenols. The activity of these compounds is dependent on whether or not a transition metal is available and the number and position of hydroxide substitutions on the heterocyclic rings (Cao *et al.* 1997). Depending on the structure, they are able to act as antioxidants in a wide range of chemical oxidation systems. This activity is due to the ease with which a hydrogen atom from an aromatic hydroxyl group can be donated to a free radical and the ability of an aromatic compound to support an unpaired electron due to delocalization around the  $\pi$  - electron system (Duthie *et al.* 2000). From a biological standpoint, this is important because antioxidant compounds can protect cellular systems from the potentially harmful effects of processes that cause excessive oxidation. They can interrupt free radical chain reactions and scavenge free radicals (Moline *et al.* 2000). These properties are important in preventing cancer, heart, vascular, and neurodegenerative diseases (Prior *et al.* 1998). In addition, antioxidants aid the immune system of elderly individuals, and are the most promising preventative strategy against the formation of cataracts (Ames *et al.* 1993; Willett 1994).

Carcinogenesis is a multistage process of genetic change affecting proto-oncogenes or tumor suppressor genes that can be initiated by increased and persistent damage to DNA. This damage becomes apparent when the cell replicates and divides. Reactive O and N species are potential carcinogens since they can induce structural changes in DNA by oxidation, methylation, depurination, and deamination reactions. Polyphenols, such as luteolin, kaempferol, quercetin and myricetin have been shown to inhibit this oxidative damage and significantly reduce DNA damage (Duthie *et al.* 2000). This is accomplished by various mechanisms. Basic research has identified three steps in chemical carcinogenesis, and 4 corresponding potential mechanisms by which components in fruits and vegetables can act to prevent cancer.

The earliest stage of cancer induction, termed initiation, refers to immediate events surrounding the interactions between carcinogens and DNA that result in irreversible alterations of DNA. This allows the transformation of the cell to a nonmalignant state (Thompson 1994). The next stage, referred to as promotion, consists of the selection and proliferation of the initiated cells. The last stage of this process is the progression, also known as metastasis, where the benign lesion will become a highly malignant rapidly growing neoplasm. The prevention of cancer is determined by the interception of DNA-reactive elements, the activation and detoxification of potential carcinogens, and the interference with the proliferation of mutated cells. Repeatedly, studies on fruits and vegetables have shown their ability to interfere with each step in chemical carcinogenesis.

Many plants are high in antioxidants, and these antioxidant compounds are efficient interceptors of DNA-reactive elements. Presumably, since most mutagenic agents are deficient in electrons, they are attracted to electron-rich sources in the cell. DNA, RNA, and proteins have a high nucleophilic potential to react with these unstable mutagenic radicals, and when stable bonds form between the two reactants, damage occurs (Figure 2-1). When consumed, the antioxidants in fruits and vegetables can reduce damage to the DNA, presumably by presenting alternate targets for attack by the carcinogenic radicals (Wargovich 2000). For example, the hydrogen atom of the OH group of vitamins and other phenolics is very easy to remove, thus free radicals preferentially combine with these antioxidants instead of lipids, DNA, RNA, and proteins. The radicals produced in the reaction are relatively unreactive, and in the case of vitamin E, is able to convert back to its original state by accepting a hydrogen from another antioxidant such as vitamin C (Thompson 1994).



**FIGURE 2-1.**  
**Role of free radicals in disease. Antioxidants, like those contained in fruits and vegetables form alternate targets for attack by the reactive radicals (R·).**

The protection against cancer by antioxidants is supported by a wealth of information on the association of fruits and vegetables in the diet and a decreased risk of cancer formation. As evidenced by more than 200 case-control or cohort studies, people



consuming higher amounts of fruits and vegetables or those containing high levels of blood carotenoids were less prone to develop various cancers. In addition, there is strong evidence for an inverse relationship between vegetable and fruit intake and lung, stomach, colon, oral, esophagus, larynx, pancreas, bladder, breast, and cervical cancers (Willett 1994; Wargovich 2000). According to the American Institute for Cancer Research, fruit and vegetable intake plays a strong protective role in four tumor sites: oral-pharynx/esophagus, lung, stomach, and colon. Furthermore, there is strong supporting data that consumption of fruits and vegetables results in a reduced risk for pancreas, breast, and bladder cancers. Of equal importance was the finding that no increase in cancer risk at any tumor site has been reported for habitual consumers of fruits and vegetables (Wargovich 2000). Smith *et al.* (1999) gave a controlled elderly population fruit and vegetable supplements and reported that it resulted in a decrease in DNA damage. The decrease in DNA damage is one probable explanation for the increased health benefits associated with consuming fruits and vegetables (Smith *et al.* 1999).

Antioxidant inadequacy is associated with oxidative damage to DNA of the germ line as well as somatic cells. Oxidative lesions in sperm are increased 250% when the ascorbate levels are below normal in seminal fluid. These reduced ascorbate levels have been correlated with smoking and childhood cancer in the offspring (Ames *et al.* 1993).

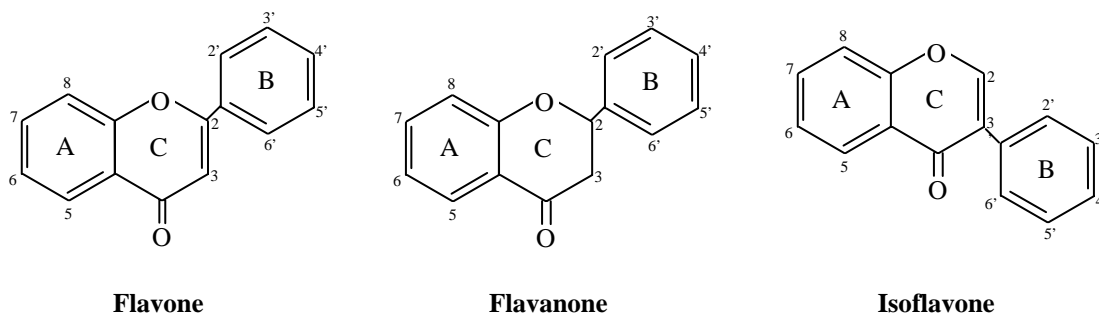
In addition to the reduction in cancer rates, high consumption of antioxidants is related to reduced risk of cardiovascular disease including heart attack and stroke. There is valid data showing that vitamin E combines with LDL (low density lipoprotein)

cholesterol and prevents its oxidation (Weisburger 2000). In a cross-cultural study of middle-aged European men, an inverse correlation was observed between levels of antioxidants, particularly vitamin E, in the plasma and ischemic heart disease mortality. In a prospective study, a similar correlation was seen in females between coronary heart disease and the intake of vitamin E or  $\beta$ -carotene (Thompson 1994).

Based on current knowledge of the genetic variation in various plant antioxidants, conventional plant breeding holds significant promise for developing genotypes of fruits and vegetables with improved antioxidant content and composition. In addition, direct genetic manipulation is a potential tool to improve the antioxidant and nutrient levels in various fruits and vegetables (Kalt and Kushad 2000).

### ***Phenolics and Polyphenols***

Phenolics, ubiquitous to the plant kingdom, are composed of several classes of compounds including flavonoids (flavones, isoflavones, flavanones), anthocyanins and catechins. The phenylpropanoid pathway synthesizes the majority of phenolic compounds, and they are characterized by cyclic rings with hydroxyl substitutions at various positions (Figure 2-2) (Duthie *et al.* 2000). These hydroxyl substitutions are quite electrophilic and react readily with the damage-causing free radicals that frequently attack cells.



**FIGURE 2-2.**  
**Basic structure of the flavonoids, flavones, flavanones and isoflavones.**

Polyphenols have been shown to exert anticarcinogenic effects by modulating enzyme systems that metabolize carcinogens or pro-carcinogens to genotoxins by converting them to less reactive compounds before they react with DNA. The Cytochrome 450 superfamily of enzymes metabolizes many pro-carcinogens to reactive intermediates that bind DNA and induce malignant transformation. Polyphenols have been shown to inhibit this family of enzymes thus reducing the formation of reactive intermediates (Stoner and Mukhtar 1995). Glutathione reductase activity in rats has also been shown to be induced by certain polyphenols (quercetin, flavones, flavanones, and tangeretin), yet inhibited by others. An induction of this enzyme is generally considered to reflect an increase in cellular protection, ensuring that potential toxins are conjugated and excreted more rapidly from the body.

Polyphenols have been implicated in the reduction of many kinds of cancer. Isoflavones have been shown to protect against estrogen related cancers such as breast, endometrial, ovarian, prostatic and colon (Arai *et al.* 2000), while others have been implicated in antiproliferative effects of human and rodent ovarian, leukaemic, intestinal,

lung and bladder cancer cells. For example, caffeic and ferulic acids prevent lung cancers in mice (Wattenberg 1992), and ellagic acid was shown to inhibit esophageal cancer when tested in rats (Mandal and Stoner 1990). Among polyphenolic compounds, the catechins are among the most potent anticarcinogenetic antioxidants tested to date. While many antioxidants are only effective against carcinogenesis in the initiation stage, green tea extracts, containing catechins are active in all phases of carcinogenesis (Dreosti *et al.* 1997).

Polyphenols can alter gene expression by interacting directly with DNA or by blocking signal transduction pathways. They have been shown to increase gap junctional intercellular communication between rat liver epithelial cells, which can reduce the early development of cancer. Much of the reduction in cancer appears to be associated with the up-regulation of the tumor suppressor gene p53, which regulates cell cycle arrest and apoptosis and the down-regulation of the proto-oncogene Ki-ras, which, when down-regulated, is associated with the inhibition of proliferation, an increase in apoptosis, and the induction of cellular differentiation (Duthie *et al.* 2000).

In addition to contributing to a reduction in cancer, polyphenols have been implicated in several studies as being inversely associated with coronary heart disease and stroke (Moline *et al.* 2000). Oxidation reactions have been reported to play a central role in atherogenesis, and epidemiological studies have shown an association between cardiovascular disease and low plasma concentrations of ascorbate, tocopherol, and  $\beta$ -carotene (Ames *et al.* 1993). Furthermore, there is an inverse correlation between quercetin intake and plasma LDL cholesterol concentration (Arai

*et al.* 2000). Polyphenols have been shown to block LDL oxidation, decrease the formation of atherosclerotic plaques and reduce arterial stiffness, leaving arteries more responsive to endogenous stimuli of vasodilatation (Moline *et al.* 2000; Arai *et al.* 2000; Duthie *et al.*, 2000). In addition, they have been shown to inhibit lipoxygenase and cycloxygenase activity leading to lower aggregation of platelets and a reduction in thrombotic tendency (Moline *et al.* 2000).

Extracts high in flavonoids have been shown to prevent the onset of the deleterious effects of aging on both neuronal and cognitive behavioral functions (Joseph *et al.* 1999). In early studies, Joseph *et al.* (1998) were able to demonstrate that feeding rats diets supplemented with strawberry and spinach extracts led to increased performance on a battery of neurological tests. They indicate that there is a synergistic effect among antioxidants in the prevention of age-related diseases, and that the observed potency of the antioxidant protection is ultimately due to “the myriad of interactions among various classes of phytochemicals present in food” that is high in antioxidant activity. There is evidence that the protective effect of these plant extracts is not due to Vitamins C or E, but to other phytochemicals. Furthermore, protection against oxidative stress may not be the only mechanism at work. Alterations in membrane rigidity caused by the presence of flavonoids may contribute to the observed increase in neuronal and cognitive behavioral functions (Joseph *et al.* 1998).

While polyphenols are quite abundant in the plant kingdom and human diet, their concentrations in food can vary by many orders of magnitude, and are influenced by several factors including species, variety, light, degree of ripeness, processing and

storage (Kuhnau 1976; Hermann 1988; Robards and Antolovich 1997; Peterson and Dwyer 1998, Duthie, 2000). In a review on tea leaves, Stagg and Millin (1975) stated that the types and proportion of catechins in tea leaves varies with season, leaf age, climate, processing, and horticultural practices. Furthermore, Crozier *et al.* (1997) demonstrated varietal differences in tomatoes and lettuce for flavanoid content. Varietal differences suggest a genetic base for flavonoid content; thus there is great potential to alter the levels of these compounds through breeding.

### ***Carotenoids***

Carotenoids are another important class of phytochemicals found in fruits and vegetables. They are also distributed in human serum, milk and tissues. Carotenoids, like flavonoids, exhibit biological activity of chemopreventive agents by inhibiting genetic damage, protecting against oxidative damage, increasing metabolic detoxification, restoring tumor suppressor function and/or inhibiting oncogene expression, enhancing the activity of gap junction communication, and stimulating immune response (Khachik *et al.* 1999). Examples of carotenoids include alpha, beta, and zeta carotene, lycopene, phytofluene, phytoene, lutein, zeaxanthin, neoxanthin, viloxanthin, antheraxanthin, and alpha and beta cryptoxanthin. Their polyene structure allows them to absorb light and to quench singlet oxygen free radicals (Hughes *et al.* 2000). This polyene chain, through addition mechanisms, allows the incorporation of free radicals or reactive species, thus slowing their propagation. When this radical propagation chain is broken, the pigment is destroyed. The antioxidant effectiveness

of a carotenoid is determined by the stability of the intermediate formed when a radical is added to the pigment structure. The more stable the intermediate, the more stable the color and the higher the antioxidant activity. One of the difficulties of working with carotenoids is that they are both light and oxygen sensitive, making them quite unstable. Perez-Galvez and Minguéz-Mosquera (2002) reported the following stability order of carotenoids when the pigments were exposed to a free radical indicator:  $\beta$ -carotene < zeaxanthin < capsanthin < capsorubin. These results are similar to those published by Terao (1989) who reported the order of stability as:  $\beta$ -carotene < zeaxanthin < canthaxanthin < astaxanthin. In contrast, Miller *et al.* (1996), determined the relative ability of dietary carotenoids to scavenge the ABTS<sup>•</sup> radical cation and found very different results. The sequence for radical scavenging abilities is canthaxanthin < astaxanthin < echienone < lutein < Zeaxanthin <  $\beta$ -cryptoxanthin <  $\alpha$ -carotene <  $\beta$ -carotene < lycopene. Results published by Bohm *et al.* (2002) using the Trolox equivalent antioxidant capacity (TEAC) assay are consistent with those of Miller, placing lycopene and its isomers above alpha and beta carotene and zeaxanthin.

According to Ames (1983),  $\beta$ -carotene is a plant's main defense against singlet oxygen generated as byproducts from the interaction of light and chlorophyll. Like polyphenols, carotenoids have been implicated in the prevention of numerous kinds of cancer including prostate (Giovannucci *et al.* 1995) and lung cancers (Willett 1994). Furthermore, carotenoids, particularly lutein, lycopene and  $\alpha$ -carotene have shown significant promise in the prevention of colon cancer. This was demonstrated by their

ability to effectively protect against formation of colonic aberrant crypt foci, which are precursor lesions of colon cancer. In addition to their preventative properties in colon cancer, lutein, lycopene,  $\beta$ -carotene, and  $\alpha$ -carotene have also been shown to inhibit proliferation of human endometrial, breast, and lung cancer cells in a dose-dependent manner (Narisawa *et al.* 1996). In another study conducted in Japan, the authors demonstrated significant inhibition of aberrant crypt foci when mice were treated during the post-initiation stage with lutein, fucoxanthin, or THC (Kim *et al.* 1998b). This indicates that not only can carotenoids provide protection against initiation, but also may provide an inhibitory activity against tumor promotion and proliferation of already initiated cells.

Perhaps most significant is the effect that lutein, lycopene and zeaxanthin have on eye health. Lutein and zeaxanthin are present in the macula (the center of the retina) and have been shown to prevent age-related macular degeneration (AMD), which results from long-term deterioration of the center of the macula (Seddon *et al.* 1994). Their role in prevention is due to their contribution in the reduction of oxidized and denatured proteins in the lens (Willett 1994). Carotenoids have also been shown to have a significant impact on the prevention of cataracts. Fourteen carotenoids have been identified in the human retina, and others have been found in lung, breast, liver, and cervical tissue.

Also linked to carotenoid levels are anti-inflammatory properties. It is believed that this is achieved by inhibiting the transcription factor NF- $\kappa$ B, which is required for maximal transcription of many inflammatory cytokines and adhesion molecules.



Reactive oxygen species activate the transcription factor by a variety of stimuli, and the antioxidant properties of carotenoids reduce the concentration of these oxygen species (Hughes *et al.* 2000). Studies conducted on the blood monocytes of healthy male non-smokers show that  $\beta$ -carotene can enhance immune response by increasing cell surface expression of major histocompatibility complex (MHC) class II monocytes. Studies involving lycopene and lutein were not conclusive (Hughes *et al.* 2000); however, they did suggest an interactive or additive effect of different carotenoids on immune function.

Consumption of fruits and vegetables has been linked to a lower risk of degenerative diseases (Aimes *et al.* 1993), heart disease mortality, reduced incidence and mortality rates for cancer (Joseph *et al.* 1999), and reduction in cardiovascular disease (Ames *et al.* 1993).

By 1995, many studies had been conducted on  $\beta$ -carotene, but there had been very few conducted on non-vitamin A active carotenoids such as lutein and zeaxanthin. While  $\beta$ -carotene was assumed to be an important chemopreventive agent due to epidemiological investigations on green and yellow vegetables, this is not necessarily the case. It was reported in 1994 that  $\beta$ -carotene actually promoted lung cancer in smokers and led to the idea that  $\beta$ -carotene might be a mere marker for other chemopreventive agents that co-exist with it in green and yellow vegetables. Nishino (1995) researched the effects of a topical application of  $\alpha$ -carotene,  $\beta$ -carotene, and fucoxanthin on mouse skin and found that  $\alpha$ -carotene reduced the incidence of skin cancer, while fucoxanthin completely suppressed it, and  $\beta$ -carotene had no significant effect. Furthermore, fucoxanthin, added to the drinking water, was able to reduce the percentage of duodenal

tumor-bearing mice, and  $\alpha$ -carotene administered in the same manner significantly reduced the number of lung tumors per mouse (Nishino 1995). Khachik *et al.* (1995) were the first to show evidence of *in vivo* oxidation of lutein and zeaxanthin, leading them to believe that these compounds possess strong antioxidant potential. In 1998, Paetau *et al.* were able to expand on this and show that when diets were supplemented with lycopene, blood serum levels also increased, thus indicating that lycopene was bioavailable, especially when processed and in the presence of fat (Paetau *et al.* 1998). Although there are over 40 dietary carotenoids, only 21 have been identified in human plasma. These include lutein and zeaxanthin which are abundant in dark green vegetables such as broccoli, spinach, and green beans, and which are also present in potato (Al-Saikhan *et al.* 1995; Al-Saikhan 2000).

Much research has been conducted on various vegetables to determine their carotenoid profiles. Peppers, one of the most notorious vegetables for containing carotenoids, has been reported to contain neoxanthin, capsorubin, violaxanthin, capsanthin, antheraxanthin, capsolutein, zeaxanthin, lutein,  $\beta$ -cryptoxanthin, and  $\beta$ -carotene (Minguez-Mosquera and Hornero-Mendez 1993). There are differering reports on the relative amounts of carotenoids in pepper, depending on the method used for analysis. Minguez-Mosquera and Hornero-Mendez (1993) reported, based on reverse-phase HPLC analysis, that lutein and zeaxanthin are absent in ripe fruit (red peppers) but present in green. Furthermore, they were able to demonstrate major difference between varieties, indicating the probability that carotenoid content is under genetic control in paper. Mejia *et al.* (1988) reported vitamin A activities of several varieties of Mexican

peppers to range from 20-109.9 ug/100gfw for  $\alpha$ -carotene, 5.5-599.4 ug/100gfw for  $\beta$ -carotene, and 1.6-7.0 ug/100gfw for  $\beta$ -cryptoxanthin.

In a comprehensive study on carotenoid levels in different fruits and vegetables, Hart and Scott (1995) analyzed both cooked and raw Brussels sprouts, beans, broccoli, cabbage, carrots, cauliflower, leeks, lettuce, parsley, peas, pepper, sweet-corn, spinach, onions, tomato, watercress and cabbage for levels of lutein, zeaxanthin,  $\beta$ -cryptoxanthin, lycopene,  $\alpha$ -carotene, and  $\beta$ -carotene. While lutein was found in all of the vegetables sampled, good sources (>1000 ug/100g) were reported to be broccoli, butterhead lettuce, parsley, peas, peppers, spinach, and watercress. Good sources of  $\beta$ -carotene were broccoli, carrots, greens, butterhead lettuce, parsley, spinach, and watercress. Zeaxanthin was found only in beans (34ug/100g), orange peppers (1608ug/100g), and sweetcorn (437ug/100g), and  $\beta$ -Cryptoxanthin was found only in orange peppers (90ug/100g). The authors reported that the content of particular items could have been affected by variety, maturity, growing conditions, season of the year, and the part of the vegetable that was consumed. They also pointed out that the outer layers (skin, leaves, etc.) were much higher in carotenoid content than the inner layers. Cooking seemed to cause little or no loss in carotenoid content, and in fact, frequently increased the levels available for extraction. Despite stability during cooking, the authors stress the importance of degradation caused by light, heat, air, and active surfaces, and recommend working under yellow light and using solvent modifiers during HPLC analysis to increase the stability of the compounds (Hart and Scott 1995). Kimura and Rodriguez-

Amaya (2002) suggested storing standards under nitrogen with BHT at the lowest temperature possible to increase their shelf life.

In a similar study to that conducted by Hart and Scott, Granada *et al.* (1992) analyzed the carotenoid content in raw and cooked Spanish vegetables. They separated the vegetables according to color (green, red-orange, and yellowish white). Lutein and/or zeaxanthin were observed in all of the vegetables analyzed with a range in raw vegetables from 1503  $\mu\text{g}/100\text{g}$  in beet to 8 $\mu\text{g}/100\text{g}$  in red cabbage. The cruciferous vegetables, frequently reported to be high in chemopreventive agents, had low lutein and  $\beta$ -carotene contents. Zeaxanthin was detected in spinach (377 $\mu\text{g}/100\text{g}$ ), sweet red peppers (148 $\mu\text{g}/100\text{g}$ ), potatoes (4 $\mu\text{g}/100\text{g}$ ), and cabbage (4 $\mu\text{g}/100\text{g}$ ) with trace amounts in red cabbage, cauliflower and onions. Sweet red peppers and squash contained 199 $\mu\text{g}/100\text{g}$  and 6 $\mu\text{g}/100\text{g}$  of  $\beta$ -cryptoxanthin, respectively, while trace amounts were detected in cabbage and potatoes. Alpha-carotene was detected in green beans, carrots, and potatoes, and lycopene was found in tomato.  $\beta$ -carotene was found in all of the vegetables analyzed. In results similar to those published by Hart and Scott, the authors reported that cooking increased the levels of carotenoids detected. These elevated levels are explained by increases in the chemical extractability of carotenoids after cooking (Granada *et al.* 1992).

Another survey study, based on HPLC analysis of 69 items, reported the carotenoids present in foods in the Finnish diet, including vegetables, fruits, berries, mushrooms, and their respective products. Seasonal differences were reported for some of these items. Lutein (mixed with zeaxanthin) and  $\beta$ -carotene were the predominant

carotenoids found in vegetables. The highest lutein values ( $\geq 4400\mu\text{g}/100\text{g}$ ) were obtained in green vegetables such as parsley, celery, dill and spinach. The amount of lutein was moderately high ( $1800\mu\text{g}/100\text{g}$ ) in broccoli, Brussels sprouts, leaf lettuce, leek, yellow pepper, and green pepper. Thirteen  $\mu\text{g}/100\text{g}$  lutein were reported in the summer crop of potato while  $60\mu\text{g}/100\text{g}$  were reported in the spring.  $\beta$ -carotene was found to be rich ( $1000\text{-}7600\mu\text{g}/100\text{g}$ ) in carrot, parsley, dill, spinach, broccoli, leek, sweet red pepper, tomato ketchup and chanterelle, while the level in potato was reported to range from  $3\text{-}8\mu\text{g}/100\text{g}$  based on the season.  $\beta$ -cryptoxanthin was found to be high in fresh peaches ( $51\mu\text{g}/100\text{g}$ ), but higher in those which had been processed. It was not detected in potato. The  $\beta$ -carotene and lutein levels were reported to be the lowest in the summer (June and August). While the levels of carotenoid in potato appear to be low, the authors point out the per-capita consumption of potato in Finland ( $187\text{g}/\text{day}$ ) far surpasses that of any other fruit or vegetable. In fact, the “other fresh vegetables” combined account for only  $101\text{ g}/\text{day}$  (Heinonen *et al.* 1989).

While many laboratories stress the importance of the instability of carotenoids, Scott *et al.* (1996) indicate that this is not as big a factor as previously perceived. In long and short term study experiments, the authors found that there were no significant losses in carotenoids in solution for a period of up to 28 days at  $37\text{ C}$ . Furthermore, the reference material (mixed vegetables) from which the extractions were performed showed no losses in carotenoids over a 3-year period. In an interlaboratory study, the authors compared variation between laboratories for HPLC analysis for lutein, zeaxanthin, lycopene,  $\alpha$ -carotene, and  $\beta$ -carotene in a vegetable mix. Their results

indicate that the differences between laboratories are not outside the accepted limits of variation (Scott *et al.* 1996).

### ***Antioxidants in Potatoes***

It has been established that fruits and vegetables in general contain antioxidants that are important to human health. Potatoes, being the fourth most important food crop worldwide, make up a significant proportion of the diet, and are of particular interest to this study. While few antioxidant studies have been conducted specifically on potato, it has been included in many survey studies of various fruits and vegetables. Arai *et al.* (2000) in a study on dietary intake of 4 different antioxidant compounds by Japanese women found that 23% of the kampherol in their diets was acquired through consumption of potato. In a study conducted on water extracts of 12 vegetables commonly consumed in the Mediterranean diet, potato was ranked among the highest in protective activity (PA) against rat liver microsome lipid peroxidation. Cluster analysis placed potato in a cluster with mushroom, garlic, and cauliflower and above white cabbage, eggplant, zucchini, onion, yellow bell pepper, tomato, celery and carrot. Furthermore, it was found processing through freezing, boiling, and freeze drying had little effect on protective activity of most vegetables (Gazzani *et al.* 1998).

Lachman *et al.* (2000) have published several review articles on the level of antioxidants in potatoes and the importance of these to the human diet. The authors state that potato tubers present a very significant source of antioxidants in human nutrition, contributing about 64mg polyphenols per capita in the U.S. In terms of a food source,

they are second only to tomatoes as a source of polyphenols. Potatoes are rich in antioxidants such as polyphenols (1226 to 4405 mg/kg), ascorbic acid (170-990mg/kg), carotenoids (as high as 4mg/kg), and alpha-tocopherol (0.5-2.8mg/kg) (Lachman *et al.* 2000).

### ***Phenolics in Potatoes***

Potatoes have been reported to be a rich source of polyphenols in the diet. It is now recognized that the major polyphenolic constituents in potato are L-tyrosine, chlorogenic acid, caffeic acid, scopolin, and cryptochlorogenic acid. Yamamoto *et al.*(1997) reported the caffeic acid level in potato tubers as high as 0.2 to 3.2 mg/kg, with the skin containing double these amounts (Yamamoto *et al.* 1997 as cited in Lachman *et al.* 2000). Other identified polyphenols in potato include neochlorogenic acid (7mg/kg), p-coumaric acid (4mg/kg), sinapic acid (3mg/kg), 3,4-dicaffeoyl-quinic acid, ferulic acid amides, and glycosides of delphinidin, quercetin, and petunidin (Lachman *et al.* 2000).

Dao and Freidman (1992) reported chlorogenic acid concentrations in potato to range from 9.7 to 18.7 mg/100gfw, with only a 2-fold difference between the 7 varieties analyzed. Concerned with after cooking darkening, the authors were interested in the amount of decrease in chlorogenic acid after cooking and processing. The total chlorogenic acid content of one variety was reduced 46% after microwaving, 60% after boiling, and 100% after baking in an oven. Furthermore, commercially obtained French fries, mashed potato flakes, and potato skins contained no chlorogenic acids, indicating that chlorogenic acid is susceptible to heat. The authors also noted the possibility that

polyphenols may be under the same regulatory control as toxic glycoalkaloids found in potatoes. In another study on after cooking darkening, Mondy *et al.* (1979) reported that phenolic acid content of potatoes increases with higher applications of nitrogen fertilizer. Potato peel extract was shown to possess antimicrobial activity at high concentrations, This activity was partially attributed to phenolic compounds found in potatoes. The phenolic acid profile was reported to be chlorogenic acid (50.3%) caffeic acid (41.7%), gallic acid (7.8%), and protocatechuic acid (0.21%) (Rodriguez de Sotillo *et al.* 1998). The stability of potato peel extracts had previously been investigated by the same group, with results contrary to those reported by Dao and Freidman (1992). Prior to analysis, the authors autoclaved potato peel waste for 10 minutes and determined that it had no affect on the phenolic concentration. Comparing both water and methanol extractions, it was determined that the concentration of total phenolics was 41.65 mg/100g and 32.15mg/100g, respectively. Increasing the temperature for the water extraction resulted in a total phenolic yield of 48mg/100g; however it altered the relative composition of the phenolics identified. The major phenolics identified in the potato peel extract were chlorogenic acid, gallic acid, p-coumaaric acid, and caffeic acid. Storing the extract for seven days at 4 C and 37 C in the dark had no apparent effect on phenolic concentration. Extracts stored at 25 C in the light lost all of their chlorogenic acid by day seven, while the caffeic acid concentration increased. The increase in caffeic acid was presumably a degradation product of chlorogenic acid; however, not all of the chlorogenic acid could be accounted for in this fraction. The loss of chlorogenic acid is attributed, at least in part, to exposure to light (Rodriguez *et al.* 1994).



Both environmental conditions and genetics have been reported to have an impact on the level of polyphenols contained in potatoes. Hamouz *et al.*(1999a) reported that over a three year period potatoes cultivated on loam soils in warm dry regions with low altitudes contained a lower amount of total phenolics than those cultivated in cooler and more humid regions on sandy loam soil. Furthermore, significant differences in total phenolics were found between varieties (Agria and Karin), and these differences were not significantly altered by year. Depending on the variety and location, total phenolic contents were reported to range from 36.85 mg/100gfw to 52.89 mg/100gfw. In a similar study conducted by the same group, it was determined that organically grown potatoes contained higher levels of phenolics than did the same varieties grown in a conventional manner. The authors attributed the differences in values to the harsher growing conditions of the organically grown potatoes. It is hypothesized that the chemically untreated plants defend themselves against unfavorable extrinsic factors with higher levels of polyphenols. The levels of polyphenols were reported to range from 35.54 mg/100gfw to 56.08 mg/100gfw. In agreement with the aforementioned study, significant differences were reported between locations and varieties (Hamouz *et al.* 1999b).

Lewis *et al.* (1999) investigated the changes in flavanoid and phenolic acid concentrations during development and storage of colored potatoes. Following a time-course study, it was reported that flavanoid concentrations increased with increasing tuber weight, reaching a maximum of 550 $\mu$ g/gfw in tubers weighing between 250 and 400 g. These levels decreased as the tubers grew larger, but this decrease was attributed

to a dilution effect. The phenolic acid concentration peaked at a tuber weight between 70 and 100g, then decreased in tubers between 150-400g. Storage of the tubers at 4 C resulted in a slight increase (from 2500 to 2800  $\mu\text{g/gfw}$ ) from harvest to 120 days after storage. After the initial 120 days of storage, no changes were observed. In all cases, individual compounds within the anthocyanin, flavonoid, or phenolic classes, changes were similar. No changes were observed in the ratios of individual compounds during storage.

While little is known about the antioxidant content of wild potato species, a limited screen was performed on *S. acaule*, *S. berthaultii*, *S. gourlayi*, *S. oplocense*, *S. sanctae-rosae*, *S. sparsipilum*, *S. spegazzinii*, and *S. stenotomum* (Lewis *et al.* 1998a). While the study analyzed many parts of the plant, including skin, flesh, flowers, and leaves, since only the tubers are involved in nutritional value, this discussion will be limited to levels of phenolics and flavanoids in the skin and the flesh. For all species, the concentration of phenolics was considerably higher in the skin than in the flesh. Phenolic acids in the skin of wild species ranged from 602 to 3035  $\mu\text{g/gfw}$ , while levels in the flesh ranged from 84 to 274  $\mu\text{g/gfw}$ . In skin extracts, chlorogenic acid accounted for 40-50% of the total phenolic acid content, while caffeic acid was present at 10-30%. A more diverse phenolic profile was observed in the flesh of wild species, which contained 30-40% protocatechuic acid, 20-30% chlorogenic acid, and 20-30% p-coumaric acid. The level of phenolics in *S. tuberosum* ranged from 157  $\mu\text{g/gfw}$  in the flesh, and 1668-4323  $\mu\text{g/gfw}$  in the skin. In the wild species, flavonoid concentrations ranged between 20 and 170  $\mu\text{g/gfw}$  in the skin, and from 0-25  $\mu\text{g/gfw}$  in the flesh. The

major flavonoids in the skin and flesh were catechin, epicatechin, eriodictyol, and naringenin. The concentration of flavonoids was significantly higher in *S. tuberosum* than in the wild species. The effects of disease were noted to greatly increase the concentrations of total phenolic acids and flavonoids. It was reported that infection with late blight increased the flavonoids (epicatechin, eriodictyol, and naringenin) 100 fold. These flavonoids were not observed in healthy tubers. P-hydroxybenzoic acid was found in tubers of some wild species, but was completely absent in the *S. tuberosum* genotypes analyzed (Lewis *et al.* 1998b).

In a detailed study on anthocyanins, flavonoids, and phenolic acids, Lewis *et al.* (1998a) determined the major phenolic acids present in the skin of potatoes were chlorogenic acid, caffeic acid, protocatechuic acid, vanillic acid, p-coumaric acid, ferulic acid, sinapic acid, salicylic acid, and an unidentified phenolic acid. The flavanones, eriodictyol and naringenin were also present in moderate quantities. Phenolic acids present in low concentrations were catechin, syringic acid, and cinnamic acid. The primary phenolic acids present in tubers were chlorogenic acid, caffeic acid, protocatechuic acid, p-coumaric acid, ferulic acid, and traces of gallic acid, sinapic acid, catechin, epicatechin, and eriodictyol. Quantification of the phenolic acid components of tuber skins revealed that they contained 2000-5000  $\mu\text{g/gfw}$  of phenolic acids, 200-300 $\mu\text{g/gfw}$  flavonoids, and 0-7000  $\mu\text{g/gfw}$  anthocyanins. Purple and red skinned tubers contained almost twice the concentration of phenolics than did white skinned tubers. Differences were also noted between seasons. All tuber skins showed high concentrations of chlorogenic acid (1000-4000  $\mu\text{g/gfw}$ ), with moderate amounts of

protocatechuic acid (100-400  $\mu\text{g/gfw}$ ), caffeic acid (40-500  $\mu\text{g/gfw}$ ), vanillic acid (20-200  $\mu\text{g/gfw}$ ), and sinapic acid (20-250  $\mu\text{g/gfw}$ ), with lower concentrations of gallic acid, syringic acid, p-coumaric acid, ferulic acid, salicylic acid, and cinnamic acid (all 0-30  $\mu\text{g/gfw}$ ). Furthermore they contained catechin, epicatechin, eriodictyol, kaempferol, and naringenin (all having 10-150  $\mu\text{g/gfw}$ ), and lower concentrations of quercetin, myricetin, and rutin. Tubers contained much lower concentrations of phenolic acids, flavonoids, and anthocyanins than did the skin in both the wild and cultivated genotypes. The concentration of phenolic acids in the flesh was reported to be 100-600  $\mu\text{g/gfw}$ , flavonoids 0-30  $\mu\text{g/gfw}$ , and anthocyanins 0-2000  $\mu\text{g/gfw}$ . Unlike in the skin, little variation was noted between seasons in the tubers. Tubers with colored flesh had three to four times the concentration of phenolic acids than white-fleshed tubers. Levels of phenolic acids reported in potato tubers were as follows: Chlorogenic acid (30-900  $\mu\text{g/gfw}$ ), protocatechuic acid (50-200  $\mu\text{g/gfw}$ ), vanillic acid (5-40  $\mu\text{g/gfw}$ ), p-coumaric acid (5-40  $\mu\text{g/gfw}$ ), and traces of other phenolic acids. The differences in relative levels of these compounds were significant between tissues (Lewis *et al.* 1998a).

In a comprehensive review on potato polyphenols, Freidman (1997) reported that chlorogenic acid constitutes up to 90% of the total phenolic content of potato tubers. It is stated in the literature that spectrophotometric analysis of potato chlorogenic acid gave higher values than did analysis by HPLC or GLC. Freidman points out that these values may be higher because chlorogenic acid isomers contribute to the total absorbance when using spectrophotometry. HPLC is able to differentiate between these isomers; however, this method may not always be satisfactory because of time and light dependent changes

undergone by chlorogenic acid. Depending on the objective of the study (whether or not there is interest in degradation products), UV methods may have an advantage over HPLC.

Reeve *et al.* (1969) reported that phenolic acids are not evenly distributed throughout the tuber tissue. This has been verified in numerous studies conducted after this original report. Chlorogenic acid is much more concentrated in outer tissue zones such as the skin. It is also highly concentrated in the phloem and phloem parenchyma tissues of both the cortex and the perimedullary zone. Furthermore, tyrosine, though more evenly distributed than chlorogenic acid, is more concentrated in the stem end of the tuber than in the bud end, and it is probably more concentrated in the central tissue as opposed to the outer tissues.

### ***Carotenoids in Potatoes***

In possibly the most comprehensive review of the literature on potato carotenoids Gross (1991) compiled copious amounts of information including levels of various carotenoids, localization in the tuber, storage effects, and processing effects. Gross begins by stating that the skin of potato tubers varies from brownish to deep purple, and that flesh color is normally white to yellow, and occasionally purple. He goes on to say that potatoes, even white ones, contain carotenoids, but this was not discovered until about 1940 when some contradictory data was published by Lampitt and Goldenberg (1940). In 1939, Schmid and Lang offered the first proof that the yellow color of the potato flesh was imparted by carotenoids. This proof was given when the Kipfler potato

was analyzed in connection with “yellow fleck” disease. Many of the articles to which Gross referred are referenced later in this review on potato carotenoids. In his summary of these articles, however, Gross concludes that the total carotenoid content found in potatoes was between 27 and 243  $\mu\text{g}/100\text{gfw}$ . Intensely yellow cultivars had a carotenoid content of about 300  $\mu\text{g}/100\text{gfw}$ , whereas the white-fleshed cultivars had much lower total carotenoid levels of about 30-70  $\mu\text{g}/100\text{gfw}$ . The carotenoid profile was dominated by epoxides with lower levels of xanthophylls and even lower levels of carotenes. In yellow potatoes, up to 80% of the carotenoids were found in the form of epoxides, with violaxanthin (40-70%) the major carotenoid, followed by lutein epoxide. Lutein was the major pigment found in white potatoes and the second major pigment found in those with yellow flesh.  $\beta$ -carotene and neoxanthin were identified at low levels in the potato tuber. Breaking down total carotenoids into individual components, Gross reported the following levels in yellow-flesh potatoes:  $\beta$ -carotene (3-5  $\mu\text{g}/100\text{gfw}$ ), lutein and zeaxanthin (40-70  $\mu\text{g}/100\text{gfw}$ ), lutein epoxide + antheraxanthin (15-18  $\mu\text{g}/100\text{gfw}$ ), violaxanthin (80-110  $\mu\text{g}/100\text{gfw}$ ), neoxanthin (4-6  $\mu\text{g}/100\text{gfw}$ ), and neoxanthin A (8-10 $\mu\text{g}/100\text{gfw}$ ) (Tevini *et al.* 1984 as cited by Gross 1991).

Carotenoid content varies according to variety, method of analysis, and the laboratory performing the procedure. Frequent modifications to extraction protocol, such as cooking, saponification, solvents, HPLC column used, etc., can have effects on the amount of carotenoids reported. In 1943, Von Elver reported the total carotenoid content of steamed yellow-flesh varieties grown in northern Sweden as 80-260  $\mu\text{g}/100\text{gfw}$ . Seven to ten  $\mu\text{g}/100\text{gfw}$  was reported to be carotenes. Two years later,

Caldwell *et al.* (1945) analyzed 19 white and three yellow-fleshed potato cultivars and reported a total carotenoid content of 14-54 and 110-187 respectively. As technology progressed, scientists were able to discriminate between different carotenoids, and in 1947, Brunstetter and Weisman analyzed Kathadin potatoes grown in Maine and Louisiana. They reported a total carotenoid content of 60  $\mu\text{g}/100\text{gfw}$ , and further broke this down into  $\beta$ -carotene (6  $\mu\text{g}/100\text{gfw}$ ), lutein (10-16  $\mu\text{g}/100\text{gfw}$ ), and  $\zeta$ -carotene (2.2  $\mu\text{g}/100\text{gfw}$ ). Twenty years later, Kasim (1967) analyzed nine German varieties and reported total carotenoids (199-560  $\mu\text{g}/100\text{gfw}$ ),  $\beta$ -carotene-5,6,5,6'-diepoxide (33-108  $\mu\text{g}/100\text{gfw}$ ), lutein (30-119  $\mu\text{g}/100\text{gfw}$ ), violaxanthin (8-29  $\mu\text{g}/100\text{gfw}$ ), and lutein 5,6-epoxide (81-257  $\mu\text{g}/100\text{gfw}$ ). In addition, he tentatively identified neoxanthin (Kasim, 1967 as cited by Gross 1991). The following year, Le page (1968), working on Canadian white potatoes reported that nearly half of the carotenoid content was composed of lutein (48.5%) while the rest was composed of  $\alpha$ -carotene (6.4%),  $\beta$ -carotene (16.3%), an unidentified pigment (14.2%), and lutein 5,6-epoxide (14.8%)(Le page, 1968, as cited by Gross, 1991). Thirteen German potato varieties analyzed by Iwanzik *et al.* (1983) were reported to have the following distribution: Total carotenoids (27.4-328.9  $\mu\text{g}/100\text{gfw}$ ), lutein (15.5-57.3  $\mu\text{g}/100\text{gfw}$ ), violaxanthin (20.6-67.8  $\mu\text{g}/100\text{gfw}$ ), lutein 5,6-epoxide (5.7-29.9  $\mu\text{g}/100\text{gfw}$ ), and neoxanthin (3.5-20.8  $\mu\text{g}/100\text{gfw}$ ).

Yellow flesh varieties are assumed to contain higher antioxidant activity than white flesh varieties because of the carotenoid pigments lutein and zeaxanthin, which contribute to the yellow flesh color and are known to have antioxidant activity. Six

major carotenoids were detected by Lu, *et al.* (2001) in eleven diploid and two yellow-flesh tetraploid cultivars. These were neoxanthin, violaxanthin, lutein-5-6-epoxide, lutein, zeaxanthin, and an unknown carotenoid. The total carotenoid content in the diploid yellow-flesh clones was 3-13 fold higher than that of Yukon Gold, suggesting that wild germplasm may be a good source for carotenoid genes in potato. An “exponential relationship between total carotenoid content and tuber yellow intensity” was reported.

In a survey study, Granada *et al.* (1992) reported that potato contained 12 µg/100g lutein, 4 µg/100g zeaxanthin, 1 µg/100g β-carotene, and trace amounts of β-cryptoxanthin and α-carotene. Following boiling, these values went up to 44 µg/100g lutein, 21 µg/100g zeaxanthin, and 326% in β-cryptoxanthin (Granada *et al.* 1992). Heinonan *et al.* (1989) reported similar results; however, while the relative order of the ranked vegetables remained the same, the amount of carotenoids detected in most species tended to be higher than those reported by Granada. This was not necessarily the case for potato, however. While the lutein value in the summer crop was near identical to that reported by Granada (13µg/100g), and the spring crop was much higher (60µg/100g), these values included zeaxanthin since they were unable to separate the peaks on the HPLC equipment available at the time. Bushway and Wilson (1982) reported the levels of alpha and β-carotene in raw potatoes to be 1-8 µg/100gfw and 13-15 µg/100gfw, respectively.

Pendlington *et al.* (1965), sparked by the observation that the flesh color of potato can vary from “white to pale yellow depending on variety,” were among the first



to analyze the carotenoid content of potatoes. They reported that potato contained eight major and four minor pigments. Though they varied according to variety, the pigments which were identified as being common to all varieties were  $\beta$ -carotene,  $\beta$ -carotene-5,6-monoepoxide, unknown I, cryptoxanthin-5,6-diepoxide, lutein, *cis*-violaxanthin, *cis*-antheraxanthin-5,6-monoepoxide and *cis*-neoxanthin. These results were similar to those reported by Tevini and Schonecker (1986) who reported that potato tubers contain both free carotenoids and carotenoid esters. Free carotenoids were reported to be neoxanthin, violaxanthin, antheraxanthin, lutein-5,6-epoxide, lutein and  $\beta$ -carotene.

Brown *et al.* (1993a) conducted an inheritance study on orange flesh potatoes, which were discovered in diploid breeding populations. The orange flesh varieties were crossed with one another and with a yellow flesh variety, and segregation patterns were analyzed. Consistent with previous results published by Fruwirth (1912), the authors determined that a single gene that is dominant over white flesh controls the yellow flesh phenotype. The backcross population supported a single gene hypothesis for the control of orange vs. white flesh, and it was concluded that a single gene controls orange, white and yellow flesh, with orange flesh dominant to yellow flesh, and yellow flesh dominant to white (Brown *et al.* 1993c).

Breithaupt and Bamedi (2002) analyzed, via HPLC and MS, the carotenoids and carotenoid ester content of four yellow and four white-fleshed potato cultivars commonly found in the German market. The major carotenoids identified were violaxanthin, antheraxanthin, lutein, and zeaxanthin, with minor levels of neoxanthin,  $\beta$ -cryptoxanthin, and  $\beta$ -carotene. The total concentration of the four main carotenoids

reached 175 $\mu\text{g}/100\text{g}$ , and the sum of the carotenoid esters accounted for 41-131  $\mu\text{g}/100\text{g}$ , indicating that carotenoid esters should be regarded as quantitatively significant compounds in potato. Analysis of the yellow flesh varieties revealed the following average results: Violaxanthin (9-66  $\mu\text{g}/100\text{gfw}$ ), antheraxanthin (21-48  $\mu\text{g}/100\text{gfw}$ ), lutein (17-41  $\mu\text{g}/100\text{g}$ ), zeaxanthin (9-78  $\mu\text{g}/100\text{gfw}$ ),  $\beta$ -cryptoxanthin (3-5  $\mu\text{g}/100\text{gfw}$ ), and all trans  $\beta$ -carotene (1.8-3.4  $\mu\text{g}/100\text{gfw}$ ). White varieties showed lower total values with the following average results: Violaxanthin (3-13  $\mu\text{g}/100\text{gfw}$ ), antheraxanthin (8-21  $\mu\text{g}/100\text{gfw}$ ), lutein (20-21  $\mu\text{g}/100\text{g}$ ), zeaxanthin (3-17  $\mu\text{g}/100\text{gfw}$ ),  $\beta$ -cryptoxanthin (0.8-2  $\mu\text{g}/100\text{gfw}$ ), and all trans  $\beta$ -carotene (1-3  $\mu\text{g}/100\text{gfw}$ ). The authors state that neither white nor yellow fleshed potatoes indicated any particular carotenoid was responsible for their inherent color, and that total carotenoid levels seemed to be a good tool to differentiate between the two groups (Breithaupt and Bamedi 2002).

Al-Saikhan *et al* (1994) analyzed 10 yellow-fleshed Texas grown varieties and reported a range of 1.47-20.69  $\mu\text{g}/100\text{g}$  lutein, and 3-51  $\mu\text{g}/100\text{g}$  zeaxanthin. The orange flesh varieties analyzed in this study were much higher than the yellow, with lutein and zeaxanthin levels of 120-148 $\mu\text{g}/100\text{g}$  and 1242-2055  $\mu\text{g}/100\text{g}$ , respectively. As in previous studies, the white-fleshed varieties had lower levels of carotenoids, with levels of lutein and zeaxanthin reported to be 3-13  $\mu\text{g}/100\text{g}$  and 2-4 $\mu\text{g}/100\text{g}$ , respectively. Differences were noted between location and fresh vs. frozen samples. In continuing studies, Al-Saikhan (2000) reported the levels of lutein, lutein-epoxide,

neoxanthin, violaxanthin, zeaxanthin, and total carotenoids for five yellow-fleshed and one white-fleshed variety grown in two locations (Colorado and Texas). Total carotenoid levels as well as levels of lutein, lutein epoxide, violaxanthin and zeaxanthin were significantly higher in Texas-grown tubers. Furthermore, significant differences were found between varieties for all carotenoids analyzed. Ranges in carotenoid content among the Texas yellow-fleshed varieties studied were as follows: Lutein (6.75-12.47  $\mu\text{g}/100\text{gfw}$ ), lutein epoxyde (0.65-0.1.46  $\mu\text{g}/100\text{gfw}$ ), neoxanthin (16.77-38.27  $\mu\text{g}/100\text{gfw}$ ), violaxanthin (59.53-198.67  $\mu\text{g}/100\text{gfw}$ ), zeaxanthin (0.82-2.80  $\mu\text{g}/100\text{gfw}$ ), and total carotenoids (272.3-453.37  $\mu\text{g}/100\text{gfw}$ ). As reported in previous studies, the white-fleshed variety Russet Norkotah was lower than the average yellow flesh variety with the following levels reported: Lutein (7.99  $\mu\text{g}/100\text{gfw}$ ), lutein epoxyde (0.08  $\mu\text{g}/100\text{gfw}$ ), neoxanthin (4.98  $\mu\text{g}/100\text{gfw}$ ), violaxanthin (6.36  $\mu\text{g}/100\text{gfw}$ ), zeaxanthin (0.73  $\mu\text{g}/100\text{gfw}$ ), and total carotenoids (97.44  $\mu\text{g}/100\text{gfw}$ ). Table 2-1 is included for comparison purposes.

TABLE 2-1 – A comparison of different levels of carotenoids detected by various authors.

	Total	Lutein	Zea-xanthin	$\beta$ -carotene	$\alpha$ -carotene	$\beta$ -cryptoxanthin	Neoxanthin	Violaxanthin	Lutein 5,6-epoxide	Antheraxanthin
<b>Gross<sup>a</sup></b> Yellow White	300 30-70									
<b>Tevini<sup>b</sup></b> Yellow		40-70	See Lutein	3-5	NA	NA	4-6	80-110	15-18	Combined with lutein epoxide
<b>Von Elver<sup>c</sup></b> Yellow	80-260									
<b>Caldwell<sup>d</sup></b> Yellow White	110-187 14-54									
<b>Brunstetter<sup>e</sup></b> Kathadin	60	10-16		6						
<b>Kasim<sup>f</sup></b>	199-560	30-119					identified	8-29	81-257	
<b>Iwanzik<sup>g</sup></b>	27-329	16-57					4-21	21-68	6-30	
<b>Lu<sup>h</sup></b> Yellow White	1435-136 64-100	23-548 16-56	5-44 4-10				10-40 11-16	51-438 19-23	18-548 9-21	
<b>Granado<sup>i</sup></b> Fresh Boiled		12 44	4 21	1	trace	trace				
<b>Heinonan<sup>j</sup></b> Summer Spring		13 60	See lutein							
<b>Brown<sup>k</sup></b> Orange Yellow White		120 140 65	2055 NF NF							
<b>Breithaup<sup>l</sup></b> Yellow white	58-175 38-62	17-41 20-21	9-78 3-17	2-3 1-3		3-5 0.8-2		9-66 3-13		21-48 8-21
<b>Al-Saikhan<sup>m</sup></b> Orange Yellow White		120-148 1-21 3-13	1242-2055 3-51 2-4							
<b>Al-Saikhan<sup>n</sup></b> Yellow White	272-453 97.44	7-12 8	0.82-2.8 0.73				17-38 5	60-199 6	0.65-1.46 0.08	

<sup>a</sup>Gross, 1991., <sup>b</sup>Tevini, 1984 (as cited by Gross, 1991), <sup>c</sup>Von Elver, 1943. <sup>d</sup>Caldwell *et al.*, 1945, <sup>e</sup>Brunstetter and Wiseman, 1947., <sup>f</sup>Kasim, 1967 (as cited by Gross, 1991)., <sup>g</sup>Iwanzik *et al.*, 1983., <sup>h</sup>Lu *et al.*, 2001. <sup>i</sup>Granado *et al.*, 1992., <sup>j</sup>Heinonan *et al.*, 1989. <sup>k</sup>Brown *et al.*, 1993c., <sup>l</sup>Breithaup and Bamedi, 2002., <sup>m</sup>Al-Saikhan *et al.*, 1994. <sup>n</sup>Al-Saikhan, 2000.

The genetics of flesh color has been studied in potato since the early 1900s. In 1912, Fruwirth reported that yellow flesh color was controlled by a single gene with yellow dominant over white. This explanation has changed little since then. Schick (1956) suggested that modifying genes, in addition to the single major gene described by Fruwirth, might be involved in the inheritance of flesh color (Schick 1956 as cited by Brown *et al.* 1993c). Bonierbale *et al.* (1988) mapped the yellow flesh locus, “Y” to chromosome 3. As mentioned above, Brown *et al.* (1993c) described a segregation pattern consistent with single gene control; however, they described 3 alternate alleles (orange>yellow>white). In an alternative explanation, it is hypothesized that separate, but closely linked genes, in the repulsion phase possibly control orange and yellow flesh traits (Brown *et al.* 1993c). In a study on clone by environment interactions for yellow flesh intensity, Haynes *et al.* (1996) concluded that there was a significant interaction between clones and environments, but this interaction accounted for a very small portion of the observed total variation. Broad-sense heritability for yellow-flesh intensity on a clonal mean basis was estimated to be 0.93. While some clones were deemed unstable in their yellow flesh intensity, the estimate of broad sense heritability suggests that once an intensely yellow-flesh clone is identified, it can be grown in multiple locations and retain its flesh color.

The source of the yellow flesh color in many popular varieties is from the diploid potato species *S. phureja*. These varieties include Yukon Gold (Johnston and Rowberry 1981), Red Gold (Coffin *et al.* 1988b), and Rose Gold (Coffin *et al.* 1988a). The success of these varieties demonstrates the potential of wild species to enhance the yellow flesh color in the cultivated tetraploid *S. tuberosum*. Haynes *et al.* (1996) used a population of

*S. phureja* x *S. stenotomum* to estimate narrow sense heritability of yellow flesh color in a diploid hybrid population. In their analysis, the narrow-sense heritabilities based on male and female variance were computed as 0.99 and 0.72, respectively. Such a high estimate of narrow sense heritability suggests that the trait is due to a single dominant gene for which there is little genotype x environment interaction. Furthermore, a high estimate of narrow-sense heritability suggests that this trait could be easily manipulated through a traditional breeding approach.

Factors other than genetics have been shown to be of significant importance in determining yellow flesh intensity in potatoes. Haynes *et al.* (1994) describe an inverse relationship between tuber weight and yellow-flesh intensity. This relationship is presumably due to a dilution effect. The authors recommend sampling the 25<sup>th</sup> to 75<sup>th</sup> percentile of tubers based on weight to reduce the amount of time required for evaluation. In a subsequent study by the same group, it was determined that yellow-flesh intensity was significantly affected by environment, with the general trend of decreasing yellow-flesh intensity from south to north (Haynes *et al.* 1996).

In a comparison of two early-maturing British varieties (Sharpe's Express and British Queen), two main-crop varieties (King Edward and Majestic), and two late-maturing varieties (Korrs Pink and Arran Consul), it was determined that the early-maturing varieties had significantly higher carotenoid content than their main-crop counterparts. Furthermore, the main-crop varieties were more yellow than the late maturing varieties, thus indicating that maturity may play a role in yellow flesh intensity. In a more detailed experiment on the King Edward variety, potatoes were analyzed in a time-course experiment over a range of 10 maturities. Total carotenoid content was

shown to parallel climactic conditions, favoring rapid growth until 127 days after planting. Following this time, total carotenoid content seemed independent of sunshine and rainfall. During the rapid growth period, the epoxides were more abundant than the free carotenoids, but as the potatoes matured, the epoxides and free carotenoids became more evenly distributed. During storage, epoxides dropped in relation to free carotenoids, mainly due to the accumulation of lutein at the expense of *cis*-violaxanthin (Pendlington, *et al.* 1965).

In numerous studies on potato carotenoids, storage has been found to have an effect. Tevini *et al.* (1986) reported that during storage, the amount of carotenoid esters remained stable in comparison to the amount of free carotenoids, particularly violaxanthin. The stability of the carotenoid esters was further demonstrated by cooking. When cooked, the carotenoid esters were not altered, but the levels of free carotenoids were significantly affected. Commercial dehydration and further storage of the resulting potato products quickly translated to high losses of free carotenoids; however, carotenoid esters appeared to remain relatively stable. Similar studies were conducted on the influence of post-harvest storage temperature on potato carotenoids, with conflicting results. Thomas and Joshi (1977) reported that both irradiated and non-irradiated potato tubers increase in carotenoid content during the first three months of storage at both ambient temperatures and 2 C. This increase was followed by a gradual decrease. When analyzed after six months of storage, the carotenoid content of the non-irradiated tubers was similar to the initial level, while that of the irradiated tubers was much lower. Reconditioning of the tubers at 34-35 C for four to six days was found to result in renewed synthesis of carotenoids. Two years later, in a similar study by the same group,

it was reported that both irradiated and non-irradiated tubers showed an initial decrease in carotenoids during the first month of storage at ambient temperature, followed by a gradual increase thereafter. At 2-4 C, non-irradiated potatoes showed a 20% decrease in carotenoid content during the first month of storage followed by a steady increase, reaching the initial levels after 100 days (Janave and Thomas 1979). In addition to length of storage, temperature has been shown to have an effect on carotenoid content as well. Tubers stored at 15 and 20 C showed comparatively lower levels of carotenoids than those stored at either four or 25-30 C. At the latter temperatures, the carotenoid concentration increased with advancing storage, whereas at 15 and 20 C the carotenoid levels showed a decreasing trend during the first 3 months, remaining constant thereafter. As in previous studies, irradiated tubers always recorded lower carotenoid content than non-irradiated tubers (Bhushan and Thomas 1990).

## **Part #2 - Differentiating 7 Russet Norkotah Strains Using AFLP Marker Analysis**

Molecular markers have been successfully used in the past to distinguish cultivars of plants, strains of microorganisms, and lines of animals from one another, thus indicating this approach could lead to readily distinguishable markers between Russet Norkotah and its strains.

Among markers that have been developed and readily used are isozymes, RFLPs, RAPDs, AFLPs, ISSRs, and SSRs (microsatellites). There are advantages and disadvantages to each of these markers.

Of great interest is the work that has been conducted using molecular markers to distinguish between somoclonal variants. While these studies were conducted primarily on tissue culture derived variants, and met with mixed results, they appear to be



promising techniques for distinguishing closely related genotypes from one another. Since strain or sub clonal variants can be viewed as analogous to tissue culture derived somoclonal variants, except that they occur in the field, it is reasonable to assume that similar techniques and approaches can be used to differentiate field derived subclonal selections. Investigators working to distinguish somoclonal variants are quick to point out both practical and theoretical weaknesses in previously attempted methods. They begin by stating that phenotypic analysis, while simple and cost effective, does not detect recessive mutations or cryptic changes in the genome, and perhaps most importantly, are quite time consuming since the plants must be grown out (Brown *et al.* 1993b).

### ***Karyological and Isozyme Analyses***

Karyological analysis is able to reveal significant chromosomal changes such as gross rearrangements and alterations in ploidy levels; however, small chromosomal rearrangements and alterations in specific genes are frequently missed (Isabel *et al.*, 1993).

Once investigators discovered that examining the entire genome was not entirely effective, they moved on to techniques such as isozyme analysis that examined biochemical changes. Sabir *et al.* (1992) was able to show variation in isozyme migration times between somoclonal variants and parental varieties of beet, but frequently, isozymes are not as revealing. Douches and Ludlam (1991) examined the possibility of using isozymes to separate intraclonal variants from one another. While the isozymes were able to separate closely related genotypes of potato (even full sibs), they failed to separate intraclonal variants from one another. Isozymes are limited by the number of

available markers and are subject to alterations by environment and development, so they were abandoned for first-generation DNA analyses such as RFLPs.

### ***Restriction Fragment Length Polymorphisms (RFLP)***

Sabir, *et al.* (1992) continued their work on beet plants using RFLP markers to determine the genetic stability of tissue culture regenerants, and they were able to identify molecular differences between variants with several probes. The authors point out, however, that there was more phenotypic variation than was reflected by the isozyme and RFLP markers, thus indicating the limited success rate of these markers. Muller, *et al.* (1990) reported similar results in a study using RFLPs to differentiate somoclonal variants of rice. While they were able to differentiate between somoclonal variants, the rate of phenotypic change due to tissue culture was much greater than that reflected by molecular markers. In addition, plants with “normal” phenotypes were still able to reveal altered DNA restriction patterns. One possible explanation for the polymorphisms revealed by RFLP markers is a change in methylation patterns. Since a methylation sensitive enzyme (HINDIII) was used, restriction sites could have been lost when the 5' adenosine of a recognition sequence was methylated. Another explanation for the differences between regenerants is the possibility that the callus was a genetic mosaic. Cecchini *et al.* (1992) also described methylation differences in their cytogenetic and molecular analysis of regenerated *Pisum sativum* L. (pea) plants. Cytogenetic, molecular (RFLP), and methylation differences were evident, though it was not clear whether these changes were transient or permanent. Mitochondrial DNA differences were demonstrated using wheat mitochondrial gene-specific RFLP probes on the tree *Larix*

*leptolepis*, *L. deciduas*, and the reciprocal hybrids of these two *Larix* species (DeVerno *et al.* 1994). De Verno *et al.* (1994) demonstrated that there were quantitative changes in the relative abundance of certain mitochondrial regions. Since these changes were due to mitochondrial differences, they were not always passed on to trees regenerated from the aberrant cell cultures. While the use of RFLPs to differentiate somoclonal variants was successful in some species, they have two major limitations. RFLPs are quite time consuming and costly, and perhaps, most importantly, the result of such an analysis is limited only to the gene sequence used as a probe, and thus, a small area of the genome. The relevance of this technique is severely reduced since no particular sequence has yet been identified as being directly responsible for somoclonal variation (Brown *et al.* 1993b; Isabel *et al.* 1993).

### ***Randomly Amplified Polymorphic DNA (RAPD)***

With the development of PCR and randomly amplified polymorphic DNA (RAPDs) primers, many limitations of previously used methods were overcome. Using RAPDs, large numbers of samples can be analyzed economically and quickly, small quantities of DNA are needed, and the DNA fingerprints obtained are independent of ontogenic expression. In contrast to RFLPs, most of the genome can be sampled with a potentially unlimited number of markers, making RAPDs a better marker choice (Isabel *et al.* 1993).

RAPD markers have been used on a number of species for cultivar identification and the detection of somoclonal variants, but the technique has had mixed results. While Hashmi, *et al.* (1997) were able to successfully separate peach variants, and Brown *et al.*

(1993b) were able to differentiate between *Triticum aestivum* (wheat) variants, no differences were detected between somoclonal variants of Norway Spruce (*Picea abies*) (Fourre *et al.* 1997). Sosinski and Douches (1996) had limited success using RAPDs to separate intraclonal variants of the potato variety Russet Burbank. Out of the 29 utilized RAPD primers, only one band from one primer showed variation between the six variants. Similar results were encountered by Demeke *et al.* (1993). Using 20 RAPD primers, they were able to discriminate clonal variants of Russet Burbank and those of Viking, but not those of Superior, Norland or Norgold Russet. Cabrita, *et al.* (2001) conducted a study on field-selected variants of dried fig (*Ficus carica*, L.), and were able to distinguish between clones of the same fig variety. Of the 31 RAPD primers used in the latter study, approximately 1% were able to distinguish among the clones, demonstrating the weak resolution power of the RAPD technique for this purpose.

### ***Amplified Fragment Length Polymorphisms (AFLPs)***

The advantages of using AFLPs include the fact that no sequence information is needed, they have a high multiplex ratio and thus require fewer primer combinations, they are insensitive to the template DNA concentrations, and they are highly reproducible (Breyne *et al.* 1999; Vos *et al.* 1995; Becker 1995). AFLPs can be tailored according to the complexity of the genome, and, by altering various steps in the process, have proven to be successful on organisms with very large genomes (Han *et al.* 1999). Its applications are very versatile and include the construction of linkage maps, marker saturation at specific genomic regions, the analysis of genetic diversity, and, perhaps most importantly, cultivar identification.

AFLP marker analysis has been used successfully in plants of various species including potato. In potato, AFLPs have been used in phylogenetic studies (Kardolus 1998), fingerprinting (Kim *et al.* 1998a), as well as for development of high-resolution genetic maps (Meksem 1995). While many contend that AFLP markers contain high multiplex ratios, Meyer *et al.* (1998) point out that, in a tetraploid species, much of the associated benefit is reduced to a point where the use of an alternative multi-allelic marker type would be significantly more efficient. This reduction in efficiency is due to masking by dosage that significantly reduces the number of individual markers that can be scored in a population.

Goulao (2001) used AFLP and inter-simple sequence repeats (ISSR) to distinguish plum cultivars from one another, emphasizing that AFLP and ISSR approaches are valuable for identification of different genotypes. Combined mapping of AFLP and RFLP markers in Barley (*Hordeum vulgare* L.) demonstrated that AFLP markers seldom interrupt RFLP clusters like their RAPD counterparts, but rather group next to them (Becker *et al.* 1995), indicating that AFLPs could reveal some variation in genotypes that was not previously revealed by RFLP and RAPD analysis.

Perhaps most importantly, AFLPs have been successfully used in the past to distinguish closely related genotypes of plants. They have been used to differentiate between *Arabidopsis thaliana* ecotypes, where a low but significant level of polymorphism was detected. This is interesting considering these natural populations are self-pollinating and are probably very similar in genetic makeup. The authors indicated that AFLP analysis is a reliable classification system for distinguishing closely related varieties (Breyne *et al.* 1999). A study conducted on pecan (*Carya illinoensis*) trees

regenerated from somatic embryogenic cultures utilized AFLP analysis to determine genetic fidelity among and between lines of clonally propagated tissue culture lines after 4 years in the field. AFLP analysis readily detected differences between culture lines. Within culture lines, it was revealed that some trees exhibited greater divergence and less similarity than other trees from the same line (Wagner *et al.* 2000). Both the study on pecan and *Arabidopsis thaliana* indicate that AFLPs could be a promising approach to distinguish Russet Norkotah subclonal selections from one another.

AFLPs have been used repeatedly to determine the population structures of a number of clonally propagated species (Arens *et al.* 1998; Escaravage *et al.* 1998; Van Der Hulst *et al.* 2000; Pornon *et al.* 2000). Since these populations were wild, and sometimes ancient, the parentage was not known; however, the results of these studies revealed some important aspects of the AFLP technique. While a 2% error rate is reported on numerous occasions, the studies clearly show the ability of AFLPs to differentiate between different clonal populations. Some, however very few, differences were reported within populations, but it is not clear if these polymorphisms were due to error or mutational events.

Even more promising are studies that have been conducted using AFLPs to distinguish somoclonal variants. Cabrita *et al.* (2001) were able to distinguish between field-selected clonal variants of *Ficus carica* L. (figs). They were able to distinguish between 11 'Salidirop' clones with only eight primer combinations. Comparing their AFLP and RAPD analysis, the authors were able to demonstrate the superior resolution power of the AFLP technique. While the AFLP technique has been able to separate clonal variants of some species, it has not met with 100% success. A study of the genetic

diversity of *Populus betulifolia* (Black Poplar) revealed an “almost 100% similarity” between trees planted in the same field (Winfield *et al.* 1998). Since Black Poplar is clonally propagated and clones were planted in the same location, this study indicates that AFLP was not a good technique for discriminating between clones. The very low level of differences that was found was within the bounds of scoring errors for AFLP. These scoring errors were reported to be approximately 2% by Arens *et al.* (1998). While AFLP is not 100% successful, it could prove to be an excellent tool for distinguishing between clonal variants of Russet Norkotah.

### ***Microsatellites***

Another promising technique is microsatellite marker analysis, also known as simple-sequence repeats (SSR). While microsatellites do not have the high multiplex ratios that are found in AFLPs, and prior sequence knowledge is required to design primers, they may be co-dominant (reveal multiple alleles at a single locus) and exhibit a much higher degree of polymorphism than do any other markers (Bowers *et al.* 1996). This high degree of polymorphism is because the region of DNA that is being analyzed is a repeat motif, and thus susceptible to changes in length due to slippage of DNA polymerase during replication. Since the regions do not contain coding regions, they are generally not under selection. Therefore, modification of these areas of the genome is not detrimental to the organism, and thus quite abundant, making them a good tool to distinguish between closely related cultivars. Primers are designed that flank the repeats, and variations in lengths of repeat motifs of individuals are revealed by amplifying the DNA with the regions flanked by the primers.

Microsatellites have been used in a number of species, including potato, to distinguish between genotypes. The original microsatellite primers for potato were designed by Provan *et al.* (1996) using known potato sequences, as well as tomato primers. A single microsatellite primer was sufficient to discriminate between all 18 potato cultivars in their study, indicating that microsatellites are a potentially powerful tool for genotyping individuals, even in a tetraploid species. This work was expanded upon by Milbourne *et al.* (1997) who compared the ability of AFLPs, RAPDs, and microsatellites to genotype sixteen potato cultivars. Comparisons were based on the number of loci revealed and the amount of polymorphism detected. While AFLPs revealed the highest number of loci, it was clear that microsatellites revealed the greatest amount of polymorphism. McGregor *et al.* (2000) conducted a similar study on potato and found similar results when comparing AFLPs, multi-locus SSRs, RAPDS, Inter-simple sequence repeats (ISSRs), and single locus SSRs. AFLPs and SSRs were the most reproducible, as well as the most polymorphic of the marker systems analyzed. However, unlike the study conducted by Milbourne *et al.* (1998) McGregor *et al.* found AFLPs to be more highly polymorphic than SSRs.

Milbourne *et al.* (1998) expanded on their SSR research by using SSRs to anchor new PCR-based linkage maps to already existing RFLP maps. They reported an obvious bias in amplification toward 5' and 3' untranslated regions, with 55.8% of the SSRs in this sequence category. Introns were also significant contributors to SSRs, with 29.4%, followed by 11.8% in coding regions. Using the SSR primers identified by Milbourne *et al.*, Spooner and Raker (2002) conducted a phylogenetic study on cultivated *S. tuberosum*



and its wild relatives. Their results indicate that, while SSRs work well with *S. tuberosum*, they are less successful for phylogenetic studies of distantly related species.

Schneider and Douches (1997) investigated the ability of SSRs to discriminate between 39 commercial potato varieties, including Burbank and Russet Burbank. Using five SSR primers, they were able to discriminate between 24 of 40 potato varieties, and grouping by tuber type before SSR analysis allowed them to discriminate between all but 5 pairs of genotypes. While the five SSR primers utilized were unable to discriminate between Burbank and Russet Burbank, it does not necessarily imply that discrimination between sports is not possible with SSRs. The authors explain that as more SSRs are identified for potato, the discrimination power of this marker type will be increased.

Microsatellites have been used in species other than potato to discriminate between very closely related genotypes. Grapes are among the taxa that have been extensively examined via SSR markers. Vignani *et al.* (1996) attempted to find allelic polymorphism between seven probable somatic mutants of the grape cultivar Sangiovese. Seven microsatellite loci were analyzed in 12 clones of Sangiovese. Eleven of the clones were identical at all seven loci; however, one clone differed from the others by one allele at each of four loci. This indicates that either this was not in fact a somatic mutant of Sangiovese or that microsatellite analysis is able to distinguish between somatic mutants. In addition, 110 accessions of 25 grape taxa from the *Vitis* genetic resources collections were characterized by microsatellite analysis, and the authors strongly recommended SSRs for fingerprinting purposes (Lambooy and Alpha 1998). Later work conducted on grapes demonstrated that microsatellites could successfully discriminate among cultivars of grape sampled from seven European vine-growing regions; however, they were not

able to detect differences between closely related vines with blue and white grapes (Sefc *et al.* 2000). Through examination of the Portuguese grapevine collection via microsatellites, many of the previously assumed synonymous cultivars were not able to be differentiated (Lopes *et al.* 1999). Furthermore, SSRs were not able to differentiate between Pinots (Regner *et al.* 2000). Work on grapes indicates that SSR analysis may not be ideal for clonal discrimination; however, these results could be species specific.

Work conducted on apple (*Malus x domestica*) demonstrated that as few as three microsatellite markers were sufficient to differentiate between 21 cultivars (Guilford *et al.* 1997). Furthermore, a later study conducted on 142 accessions of 23 *Malus* species found that eight primer pairs were able to unambiguously differentiate all but five pairs of accessions. There was, however, detection of identical accessions in the collection which were previously considered to be unique, indicating that perhaps SSRs cannot differentiate between closely related *Malus* genotypes (Hokanson *et. al.* 2001). Research on barley had successes, with microsatellite markers able to distinguish between barley genotypes, even those with the same pedigree (Struss and Plieske 1998; Russell *et al.* 1997).

## CHAPTER III

### INTRASPECIFIC VARIABILITY FOR ANTIOXIDANT ACTIVITY IN POTATO (*S. TUBEROSUM* L.)

#### **Introduction**

Many consumers recognize the potato as an important source of carbohydrates, but few recognize it as an important source of vitamin C and potassium. Though there is increasing interest, relatively little is known about the important phytochemicals contained in this most-consumed vegetable. Based on the 1997-1998 National Food Consumption Survey, white potatoes ranked first among vegetables in consumption, and data from PMA, UFFVA, and ERS USDA ranked potato first among vegetables by sales, promotion, or consumption (Kolasa 1993). Therefore, considering consumption estimates, even modest antioxidant levels in potato probably play a major role in maintaining a healthy population. Unlike crops such as blueberries, potatoes have not been considered among foods important for their high antioxidant content. This is unfortunate considering the per capita consumption of potatoes in the U.S. is about 137 pounds (National Potato Council 2003), while that of blueberries stands at 13.9 ounces (North American Blueberry Council).

There is preliminary evidence to suggest that potatoes do in fact contain significant levels of important antioxidants, including phenolic acids, flavonoids, and carotenoids, among others (Al Saikhan *et al.* 1995; Al-Saikhan 2000; Arai *et al.* 2000; Gazzani *et al.* 1998; Lachman *et al.* 2000; Yamamoto *et al.* 1997; Dao and Freidman 1992; Freidman 1997). Using potato varieties high in health-benefiting compounds as

parents in a traditional breeding program could lead to the development of new potato varieties that are enhanced with these beneficial chemicals. The resulting “healthy” varieties could be used as a vector for increasing antioxidant consumption among the general public. Before this concept can be extensively promoted, antioxidant activity and specific antioxidant compounds in a wide range of genotypes must be definitively identified and their levels quantified.

Several specific antioxidant compounds have been identified in potato. Previous studies have reported phenolic concentrations in potato ranging from 157-560  $\mu\text{g/gfw}$  in the flesh and carotenoid concentrations ranging from 0-1435  $\mu\text{g}/100\text{gfw}$  (Dao and Freidman 1992; Hamouz *et al.* 1999a; Lewis *et al.* 1999; Lewis *et al.* 1998b; Lewis *et al.* 1998a). Repeated studies have indicated that the major phenolic compounds in potato are chlorogenic acid, caffeic acid, tyrosine, and tryptophan, with smaller quantities of neochlorogenic acid, cryptochlorogenic acid, p-coumaric acid, sinapic acid, ferulic acid, quercetin, myricetin, rutin, gallic acid, protocatechuic acid, vanillic acid, naringenin, catechin, epicatechin, syringic acid, cinnamic acid, kaempferol, and eriodictyol (Lachman *et al.* 2000; Dao and Freidman 1992; Monday *et al.* 1979; Rodriguez de Sotillo *et al.* 1998; Lewis *et al.* 1998b; Lewis *et al.* 1998a; Reeve *et al.* 1969). Major carotenoid constituents of potato are lutein and zeaxanthin with smaller amounts of  $\beta$ -carotene,  $\alpha$ -carotene,  $\beta$ -cryptoxanthin, neoxanthin, violaxanthin, lutein-5,6-epoxide, and antheraxanthin (Tevini *et al.* 1984 as cited by Gross 1991; Caldwell *et al.* 1945; Brunstetter and Wiseman 1947; Kasim 1967; LePage 1968 as cited by Gross 1991; Iwanzik *et al.* 1983; Lu *et al.* 2001; Granado *et al.* 1992; Heinonan *et al.* 1998; Bushway

and Wilson 1982; Pendlington *et al.* 1965; Tevini and Schonecker 1986; Brown *et al.* 1993c; Breithaupt and Bamedi 2002; Al-Saikhan *et al.* 1994; Al-Saikhan 2000).

The objective of this study was to screen a wide range of potato genotypes for antioxidant activity, and determine the specific compounds contributing to this activity. Genotypes showing high levels of total antioxidant activity, or unusually high levels of particular compounds, will be selected as parents for use in the Texas Potato Variety Development Program. The long-range objective of the program in relation to this project is to develop potato varieties that can be promoted to the public at large as a vector for antioxidant consumption.

## **Materials and Methods**

### ***Plant Materials***

Named varieties and advanced selections entered into the Texas Potato Variety Development Program's 2000 and 2001 Field Day Trials grown near Springlake, Texas were utilized in this study. Entries in the 2000 Field Day Trial included 67 advanced selections and 24 named varieties, including Russet Norkotah and eight Russet Norkotah clonal variants (Table 3-1). The 2001 Field Day Trial was comprised of 73 advanced selections and 27 named varieties, including Russet Norkotah and the eight clonal variants (Table 3-2). Thirty-five advanced selections and 18 named varieties were common between the two years (Table 3-3). In addition to the Springlake entries, potatoes grown near Dalhart, Texas in 2000 were tested in order to compare the effects of

location on antioxidant activity. These included six advanced selections and 11 named varieties (Table 3-1).

Since the majority of potatoes are consumed as French fries and potato chips, seven different types of chips were purchased from a local grocery store to determine their antioxidant activity. The brands of chips were as follows: Bob's Texas Style (Poore Brothers, Inc.), Kettle Chips (Kettle Foods), Lays Wow Original (Frito Lay), Ruffles (Frito Lay), Terra Blues (The Hain Celestial Group, Inc.), Terra Yukon Gold (The Hain Celestial Group, Inc.), Wavy Lays (Frito Lay), and Zapps – salt and vinegar (Zapps Potato Chip Co.). The genotypes of these potatoes were not known. In addition, for comparison purposes, 18 vegetables obtained at the grocery store (including potato) were analyzed for antioxidant activity. These included broccoli, cabbage, carrot, celery, cucumber, green onion, green bell pepper, zucchini, iceberg lettuce, maroon carrot, radish, red potato, romaine lettuce, spinach, white onion, white potato, yellow onion, and yellow squash.

TABLE 3-1 – *Genotypes grown in 2000, which were used in the antioxidant analysis.*

<b>Genotype</b>	<b>Location</b>	<b>Genotype</b>	<b>Location</b>
Adora	Springlake	ATX96007-1P/Y	Springlake/Dalhart
All Blue	Springlake/Dalhart	BTX1544-2W/Y	Springlake
Atlantic	Springlake	BTX1749-1Ru/Y	Springlake
Russet Burbank	Springlake	BTX1749-2Ru/Y	Springlake
Cherry Red	Springlake	BTX1810-2aR	Springlake
Chipeta	Springlake	BTX1810-3aR	Springlake
CORN3	Springlake/Dalhart	BTX1813-2R	Springlake
CORN8	Springlake	CO92059-8W	Springlake
Dark Red Norland	Springlake	COTX93032-1R	Springlake
Morning Gold	Springlake	COTX93053-4R	Springlake
Russet Norkotah	Springlake/Dalhart	COTX93068-1R	Springlake
Russet Nugget	Springlake	COTX93069-5R	Springlake
Purple Peruvian	Springlake/Dalhart	COTX94016-2	Springlake
Ranger Russet	Springlake	COTX94216-1R	Springlake
Red LaSoda	Springlake	COTX94218-1R	Springlake
Russian Blue	Dalhart	COTX95111-1Ru	Springlake
Shepody	Springlake	MWTX2609-2Ru	Springlake
Stampede	Springlake	MWTX2609-4Ru	Springlake
TXNS102	Springlake/Dalhart	MWTX4241-1W	Springlake
TXNS112	Springlake/Dalhart	MWTX548-2Ru	Springlake
TXNS223	Springlake/Dalhart	NDC4069-4R/R	Dalhart
TXNS278	Springlake	NDO4300-1	Springlake
TXNS296	Springlake/Dalhart	NDO4323-2R	Springlake
Vivaldi	Springlake	NDO4588-5R	Springlake
Yukon Gold	Dalhart	NDTX4784-1R	Springlake
A8792-1Ru	Springlake	NDTX4784-7R	Springlake
A8893-1Ru	Springlake	NDTX4784-9R	Springlake
A9014-2Ru	Springlake	NDTX4828-2R	Springlake
A9045-7Ru	Springlake	NDTX4930-5W	Springlake
A90467-14W	Springlake	NDTX5067-2R	Springlake
A90490-1W	Springlake	NDTX5407-1R	Springlake
A90586-11Ru	Springlake	NDTX5438-11R	Springlake
A92657-1R	Springlake	NDTX6345-2R	Springlake
AC87079-3Ru	Springlake	NDTX8-731-1R	Springlake
AC87138-4Ru	Springlake	TX1385-12Ru	Springlake
AC89536-5Ru	Springlake	TX1523-1Ru/Y	Springlake
AC89653-3W	Springlake	TX1673-2W/Y	Springlake
AC90636-3Ru	Springlake	TX1674-1W/Y	Springlake/Dalhart
AC91014-2Ru	Springlake	TXA549-1Ru	Springlake
AC91365-1Ru	Springlake	TXDH99-1Ru	Springlake
AO91812-1W	Springlake	TX93483	Dalhart
AOTX97275-2Ru	Springlake		
ATX84706-2Ru	Springlake		
ATX91137-1Ru	Springlake		
ATX9202-1Ru	Springlake		
ATX9202-3Ru	Springlake		
ATX92230-1Ru	Springlake		
ATX9312-1Ru	Springlake/Dalhart		

TABLE 3-2 – *Genotypes grown in the 2001 Field Day Trial, which were used in the antioxidant analysis.*

<b>Genotype</b>	<b>Genotype</b>	<b>Genotype</b>
Adora	AOTX 96458-1Ru	NDO4323-2R
All Blue	AOTX 97130-1Ru	NDTX4271-5R
CORN3	AOTX 97175-4Ru	NDTX4304-1R
CORN8	AOTX 97213-1Ru	NDTX4784-7R
Dark Red Norland	AOTX 97287-1Ru	NDTX4790-1Ru
Ilong	AOTX97164-1Ru	NDTX4828-2R
Latona	ATTX82700-12R	NDTX4828-7R
Mazama	ATTX83355-11R	NDTX4898-1Ru
Morning Gold	ATTX83355-7R	NDTX5407-1R
Platina	ATX82539-4Ru	NDTX5438-11R
Ranger Russet	ATX84378-1Ru	TC1675-1Ru
Red LaSoda	ATX84706-2Ru	TDA99-1Ru
Russet Burbank	ATX91137-1Ru	TX1385-12Ru
Russet Norkotah	ATX9202-1Ru	TX1523-1Ru/Y
Sating	ATX92230-1Ru	TX 1674-1 W/Y
Shepody	ATX9302-1Ru	
Stampede Russet	ATX9332-12Ru	
TXNS102	ATX9332-8Ru	
TXNS112	ATX96007-1	
TXNS223	ATX96744-1R	
TXNS249	ATX 97232-1Ru	
TXNS278	ATX96746-1R	
TXNS296	BTX1544-2W/Y	
Vivaldi	BTX1749-2Ru/Y	
Winema	BTX1754-1W/Y	
Yukon Gold	BTX810-1R	
A8893-1Ru	BTX810-2Ra	
A9014-2Ru	CO 92077-5Ru	
A9045-7Ru	CO92027-2Ru	
A90586-11Ru	CO93032-1R	
A92584-3BB	CO93037-6R	
AC87138-4Ru	COTX4216-1R	
AC89536-5Ru	COTX4218-1R	
AC91014-2Ru	COTX93053-4R	
AC92009-4Ru	COTX95111-1R	
AC87079-3Ru	MSE192-8Ru	
AF1753-16Ru	MSE202-3Ru	
AO92017-6Ru	MWTX2609-2Ru	
AOTX 91861-4R	MWTX2609-4Ru	
AOTX 93483-1R	MWTX548-2Ru	
AOTX 95156-4Ru	NDC5281-2R	
AOTX 96265-2Ru	NDC5372-1Ru	



TABLE 3-3 – *Genotypes grown in the 2000 and 2001 Field Day Trials, which were used in the antioxidant analysis for comparison of location.*

<b>Variety</b>	<b>Advanced Selection</b>	<b>Advanced Selection</b>
Adora	A8893-1Ru	BTX810-1R
All Blue	A9014-2Ru	BTX1810-2a
CORN 3	A9045-7Ru	COTX93032-1R
CORN 8	A90467-14	COTX93053-4R
Dark Red Norland	A90490-1	COTX93069-5R
Morning Gold	A90586-11Ru	MWTX2609-2Ru
Ranger Russet	A92657-1R	MWTX2609-4Ru
Red LaSoda	AC87079-3Ru	MWTX548-2Ru
Russet Burbank	AC87138-4Ru	NDC5281-2R
Russet Norkotah	AC89536-5Ru	NDO4323-2R
Shepody	ATX82539-4Ru	NDTX4784-7R
Stampede Russet	ATX84706-2Ru	NDTX4828-2R
TXNS102	ATX91137-1Ru	NDTX5407-1R
TXNS112	ATX9202-1Ru	NDTX5438-11R
TXNS223	ATX9202-3Ru	TX1385-12Ru
TXNS278	ATX92230-1Ru	TX1523-1Ru/Y
TXNS296	BTX1544-2W/Y	TX1674-1 W/Y
Vivaldi	BTX1749-2Ru/Y	

### ***Extraction of Antioxidants***

For the evaluation of potato antioxidant activity, total carotenoids, and individual carotenoid and phenolic components via HPLC, whole tubers were diced into quarter inch cubes. Three tubers per genotype were diced and kept separate, and a representative sample was weighed and stored at –20C until extractions were performed. Previous studies have analyzed only the center section of the tuber, but since concentrations of phenolics are known to vary from stem to bud end, and are more concentrated in the skin than in the inner tissues (Lewis *et al.* 1998a,b; Reeve *et al.* 1969), it was reasoned that antioxidant concentrations based on the entire tuber would be more representative of the concentrations consumed in the diet (Figure 3-1).

*Extraction of Phenolics* - For the evaluation of potato antioxidant activity and the HPLC analysis of phenolics, antioxidants were extracted from 5 g tuber samples by mixing 15 ml of methanol and homogenizing with an ultra turrax tissumizer from Tekmar

(Cincinnati, Ohio). Homogenized samples were centrifuged at 15,000 rpm for 15 minutes in a refrigerated centrifuge (Beckman model J2-21) using a J-17 rotor. One and a half ml of the supernatant was collected in 1.5ml snap-cap tubes for analysis of total antioxidants, and 7 ml was collected in glass vials for the analysis of individual phenolics via HPLC. The sample extracts were stored at  $-20^{\circ}\text{C}$  until analysis, and the pellet was discarded (Figure 3-1).

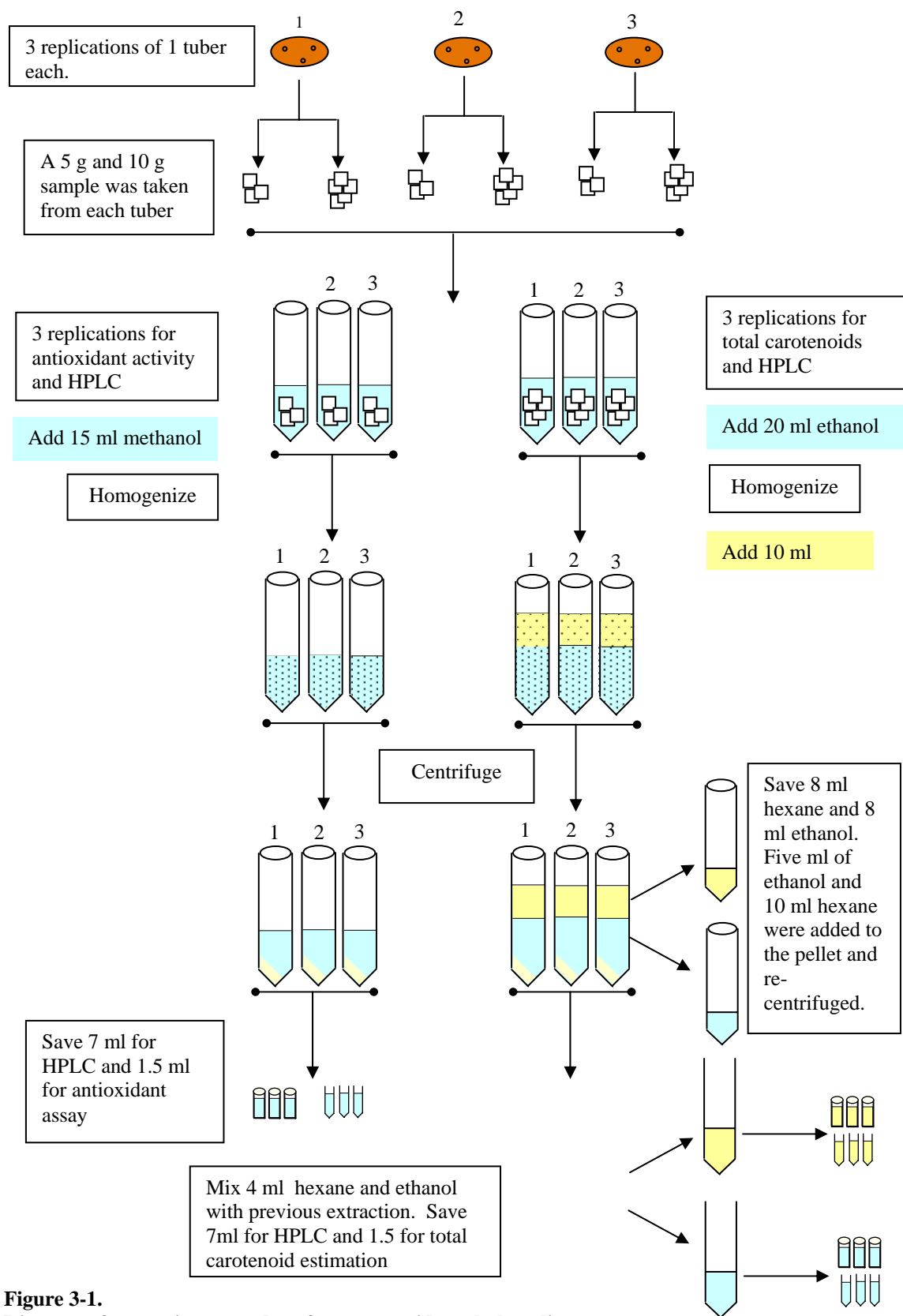
*Extraction of Carotenoids* - A 10 g sample of diced tuber tissue was used to extract carotenoids for both the total carotenoid broad screen and the analysis of individual carotenoids via HPLC. Since potatoes contain both oxygenated (i.e.,  $\beta$ -carotene and  $\alpha$ -carotene) and non-oxygenated carotenoids (i.e., lutein and zeaxanthin), both ethanol and hexane were used to ensure complete extraction. Fifteen ml of ethanol plus BHT (1g/L) was added to 10 g of tuber tissue and homogenized using an ultra turrax tissumizer from Tekmar (Cincinnati, Ohio). Five ml of ethanol +BHT (1g/L) was added to the resulting slurry, and it was incubated overnight at  $-20^{\circ}\text{C}$  to facilitate a more efficient extraction. The following day, 10 ml of hexane was added, and the sample was centrifuged for 20 minutes at 1600 rpm in a refrigerated centrifuge (Beckman model J2-21) using a J-17 rotor. Eight ml of each layer (hexane and ethanol) were saved in separate falcon tubes, and the remaining solvent was discarded, while the pellet remained at the bottom of the tube. Five ml of methanol and 10 ml of hexane were added to the pellet, and the tube was shaken. The second extract was centrifuged as described above, and 4 ml each of the hexane and ethanol layers were added to the previous extracts. Seven ml of the combined ethanol extracts were saved for HPLC analysis, and 1.5 ml

were saved for the estimation of total carotenoids. The hexane extracts were saved in an identical manner (Figure 3-1).

### ***DPPH Assay for Total Antioxidant Activity***

The determination of antioxidant activity was based on the 2,2-Diphenyl-1-picrylhydrazyl (DPPH) analysis described by Brand-Williams *et al.* (1995). DPPH, a stable radical, absorbs at 515 nm, and upon reduction by an antioxidant species, a decrease in absorbance is observed. The change in color (from purple to yellow) provides an easy and rapid assay to evaluate the antiradical activities of potato extracts. Since this study dealt with such a large number of samples, the DPPH assay was used as a broad screen to identify those genotypes that were high in antioxidant activity.

DPPH stock solution was prepared by dissolving 24 mg of DPPH in 100 ml of methanol. The stock was diluted ~10:55 until the display on the spectrophotometer at 515 nm read 1.1. Two thousand eight hundred fifty  $\mu$ l of the dilute DPPH was allowed to react with 150  $\mu$ l of the tuber methanol extract for 15 minutes, and then read on the spectrophotometer at 515 nm. All genotypes were analyzed in triplicate (Appendix O).



**Figure 3-1.**  
**Diagram of extraction procedure for carotenoids and phenolics.**

Two standard curves, one with Ascorbic acid, and one with trolox (6-Hydroxy-2,5,7,8-tetramethylchroman-2-carboxylic acid – a commonly used synthetic antioxidant), were prepared, and absorbance readings were converted to  $\mu\text{M}$  equivalents of these compounds. While most studies report antioxidant activity based on DPPH in trolox equivalents, an ascorbic acid curve was also prepared because it is a compound with which the general public is familiar, while trolox is not. Three samples were prepared separately for each concentration, and were assayed in the same manner as the potato samples. One hundred fifty  $\mu\text{l}$  of the standard at various concentrations was allowed to react for 15 minutes with 2850  $\mu\text{l}$  of the DPPH working solution. Curves were prepared based on absorbance at 515 nm.

### ***HPLC Analysis of Phenolic Compounds***

Based on the results of the DPPH analysis, the top 10% of genotypes in antioxidant activity were chosen for analysis via HPLC in triplicate. The reduction in numbers was necessary because of both monetary and time costs involved in HPLC analysis.

*Concentrating the Samples* – A 7 ml sample of the 5 g methanol extract was retained for analysis of individual phenolic components on the HPLC. The samples were dried to completion in a heated speed vac, and resuspended in 1.5 ml of methanol for analysis. Prior to injection, the concentrated samples were filtered through a 0.45  $\mu\text{m}$  syringe filter.

*The Compounds Analyzed* – Based on the phenolics previously reported in the literature, the following 19 compounds were selected for this analysis: Rutin hydrate, chlorogenic acid, gallic acid, protocatechuic acid, catechin, p-hydroxybenzoic acid, caffeic acid, vanillic acid, (-) epicatechin, p-coumaric acid, syringic acid, sinapic acid, 4'-5,7-Trihydroxyflavanone, ferulic acid, myricetin, salicylic acid, quercetin dihydrate, t-cinnamic acid, and kaempferol. Standard samples for each of these compounds were obtained from Acros Organics (Pittsburgh, PA).

*The HPLC System*– The samples were run using Waters Millennium 3.2 software on a system equipped with a binary pump system (Waters 515), an autoinjector (Waters 717 plus), a photodiode array (PDA) detector (Waters 996), and a column heater (SpectraPhysics SP8792). Compounds were separated on a 4.6 x 150 mm, 5 $\mu$ m, Atlantis C-18 reverse-phase column manufactured by Waters (Milford, MA), which was maintained at 40C. The Atlantis column was chosen based on its ability to separate polar compounds using conventional reverse-phase chromatography. For analysis of phenolics, the following gradient system was used: Solvent A (Acetonitrile), solvent B (water/HCL, adjusted pH 2.3); gradient (min/%A) 0/85, 5/85, 30/0, 35/0. The column was brought back to initial conditions, and allowed to equilibrate for 11 minutes before the following injection (Appendix P). All solvents were filtered and degassed before use. Nine point calibration curves were prepared for all standards but tryptophan, and each was analyzed at its lambda max.

### ***Broad Screen for Carotenoid Content***

It has been reported in numerous studies that carotenoid content is highly correlated with the yellow-intensity of tuber flesh, and as a result, this is frequently used as a measure of the carotenoid levels in potato (Lu *et al.* 2001; Haynes *et al.* 1994; Haynes *et al.* 1996; Haynes 2000; Janave and Thomas 1979). Based on a method published in *Current Protocols in Food Analytical Chemistry*, the carotenoids in the broad screen were determined by absorbance of the ethanol and hexane extracts at 445 nm and 450 nm, respectively (Scott 2001).

Standard curves were prepared for both the ethanol and hexane extracts to convert the absorbance into lutein and  $\beta$ -carotene equivalents, respectively. The lutein curve was prepared by determining the absorbance at 445 nm of solutions of lutein ranging in concentration from .001-.02  $\mu\text{g/ml}$ . This curve allowed the determination of tuber carotenoid concentrations in the ethanol extract ranging from 0-2000  $\mu\text{g}/100\text{gfw}$  lutein equivalents. A similar curve was prepared for the hexane extract based on the absorbance of  $\beta$ -carotene at 450 nm. This curve allowed the determination of tuber carotenoid concentrations in the hexane extract ranging from 0-667  $\mu\text{g}/100\text{gfw}$   $\beta$ -carotene equivalents.

### ***HPLC Analysis for Carotenoid Compounds***

Based on the results of the spectrophotometric broad screen for carotenoids, the top 10% of genotypes were chosen to be analyzed via HPLC.

*Concentrating the Samples* – A 7 ml sample of the 10 g ethanol and hexane extracts were retained for analysis of individual carotenoid components by HPLC. The

samples were dried to completion under a nitrogen stream and resuspended in 1 ml of 50% ethanol for analysis. Both prior to drying and following concentration, samples were filtered through a 0.45  $\mu\text{m}$  syringe filter.

*The Compounds Analyzed* – Based on previously reported studies, the following seven carotenoids were selected for this analysis: Lutein, zeaxanthin,  $\beta$ -cryptoxanthin, antheraxanthin, canthaxanthin,  $\beta$ -carotene, and violaxanthin. The lutein, zeaxanthin, canthaxanthin, and  $\beta$ -cryptoxanthin were kindly provided by Hoffman La Roche (Basel, Switzerland),  $\beta$ -carotene was purchased from Sigma-Aldrich, and antheraxanthin, violaxanthin, and antheraxanthin were purchased from CaroteNature (Lupsingen, Switzerland).

*The HPLC System*– The samples were run using Waters Melinnium 3.2 software using a system equipped with a binary pump system (Waters 515), an autoinjector (Waters 717plus), a PDA detector (Waters 996), and a column heater (SpectraPhysics SP8792). Compounds were separated on a 4.6 x 250 mm, 5 $\mu\text{m}$ , YMC Carotenoid column (C-30 reverse-phase) purchased from Waters (Milford, MA), which was maintained at 35C. The YMC carotenoid column was chosen based on its ability to separate lutein and zeaxanthin. For analysis of carotenoids, the following gradient system was used: methanol/water/triethylamine (90:10:0.1 v/v/v)(A), and methanol/MTBE/triethylamine (6:90:0.1 v/v/v)(B); gradient (min/%A) 0/99, 8/99, 45/0, 50/0, and 53/99 (Breithaupt and Bamedi 2002). The column was brought back to initial conditions, and allowed to equilibrate for 10 minutes before the following injection (Appendix Q). All solvents were filtered and degassed before use. All carotenoids were analyzed at 450 nm.



## Results and Discussion

The samples from each harvest were processed simultaneously, and stored at -20C until extraction and analysis. The DPPH assay was performed first, followed by the HPLC phenolic analysis. Carotenoid extractions were performed as phenolic samples were run on the HPLC.

### *DPPH Assay for Total Antioxidant Activity*

*Standard Curves for Ascorbic Acid and Trolox* – The standard curve for Trolox was estimated between 0 and 900 uM Trolox. The resulting equation was as follows:  $y = 888.12x + 3.4883$  where  $y = \mu\text{g trolox equivalents/gfw}$  and  $x = \text{absorbance at } 515\text{nm}$ . The  $R^2$  value for this curve was 0.9977. The curve for ascorbic acid was prepared in the same manner, with the following regression equation:  $y = 853.82x - 0.2539$ , where  $y = \mu\text{g trolox equivalents/gfw}$  and  $x = \text{absorbance at } 515$ . The  $R^2$  value for this equation was 0.998. The values reported in subsequent discussion are based on the aforementioned equations.

*Field Day Trial 2000* - A wide range of variation in antioxidant activity was found among the 67 advanced selections and 24 named varieties analyzed in the 2000 Field Day Trial. Antioxidant activity ranged from 104 to 565  $\mu\text{g trolox equivalents/gfw}$ , with an average value of 303. The same values converted to  $\mu\text{g ascorbic acid equivalents/gfw}$  ranged from 97-535, with an average value of 286. Advanced selections ranged from 103-375  $\mu\text{g trolox equivalents/gfw}$ , while antioxidant activities of the named varieties ranged from 127-565 (Table 3-4). There was a five-fold difference between the variety which was lowest in antioxidant activity and that which was highest. Analysis of

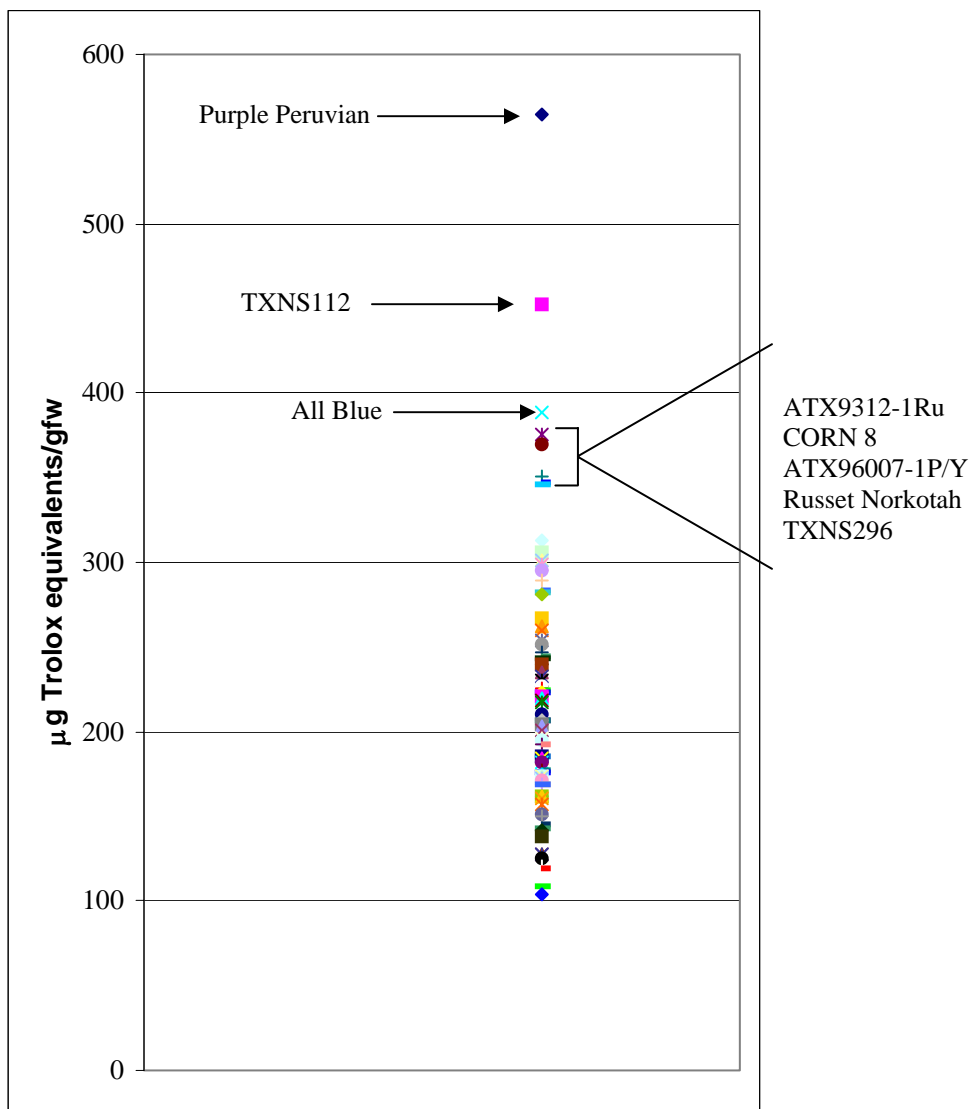
variance revealed significant differences between genotypes ( $<.0001$ ), while replications were insignificant ( $p=0.1229$ ) (Table 3-5). Due to the number of genotypes analyzed, Tukey's HSD analysis revealed little about which genotypes would be the best for use as parents. Each Tukey grouping had far more genotypes than parents desired, so the means were graphed in order to visually observe the distribution (Figure 3-2). The graph revealed eight genotypes that were above the rest of the cluster. These genotypes included Purple Peruvian, TXNS 112, All Blue, ATX 9312-1Ru, CORN 8, ATX 96007-1P/Y, Russet Norkotah, and TXNS 296. It is interesting to note that two of these genotypes contained purple flesh, and one had purple skin. This indicates that anthocyanins can be a major contributor to antioxidant activity in potato. Of interest are the significant differences observed between Russet Norkotah and its intracloonal variants when analyzed separately from the rest of the data. An analysis of variance showed a p-value of  $<.0001$  for genotype with no significant difference for replications at the  $\alpha=.05$  level ( $p=.0243$ ). TXNS112, CORN8, Russet Norkotah, and TXNS296 were found to be significantly different from CORN3 and TXNS102. Furthermore, TXNS278, TXNS223, and CORN 3 were significantly different from TXNS102 (Figure 3-3).

TABLE 3-4 – *Antioxidant activities of tubers grown in 2000.*

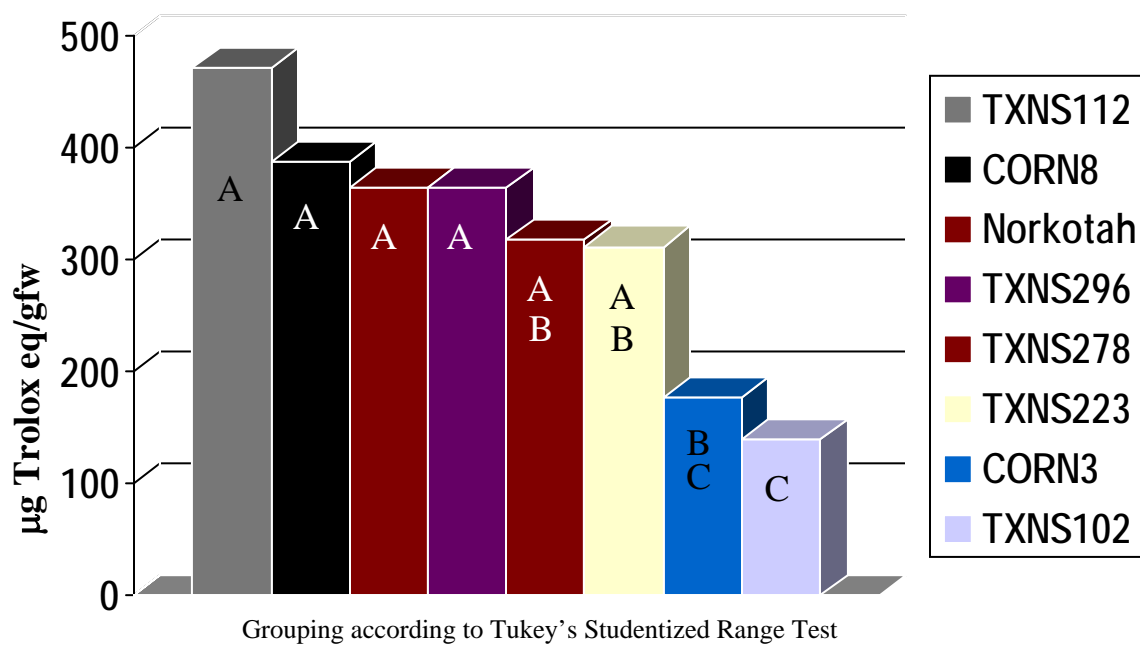
<b>Genotype</b>	<b>µgTrolox eq/gfw</b>	<b>Genotype</b>	<b>µgTrolox eq/gfw</b>
Purple Peruvian	565	AC91365-1Ru	196
TXNS112	452	MWTeX2609-4Ru	195
All Blue	389	TX1674-1W/Y	192
ATX9312-1Ru	376	NDTX4390-5W	192
CORN8	370	A9045-7	186
ATX96007-1P/Y	351	COTX93068-1R	186
Russet Norkotah	347	COTX93069-5R	185
TXNS296	346	Cherry Red	185
NDTX4828-2R	312	AC89536-5Ru	184
ATX9202-1Ru	305	TX1385-12Ru	182
ATX99137-1Ru	301	Red LaSoda	181
TXNS278	301	AC90636-3Ru	178
NDTX4784-1R	299	MWTeX4241-1W	177
TXNS223	295	NDTX5438-11R	176
AC87138-4Ru	289	A9014-2	175
NDC4069-4R/R	284	A8893-1	174
NDTX8731-1R	282	BTX1544-2W/Y	173
Chipeta	281	MWTeX2609-2Ru	173
ATX92230-1Ru	267	MWTeX548-2Ru	172
NDTX5067-2R	262	A92657-1R	171
NDTX5407-1R	260	ATX84706-2Ru	169
Ranger Russet	254	COTX95111-1	169
BTX1810-1	252	BTX1810-2a	169
NDTX4784-7R	247	ATX82539-4Ru	162
Vivaldi	245	CORN3	161
NDO4588-5	243	TXDH99-1Ru	161
NDTX6345-2R	240	BTX1749-1Ru/Y	160
Russet Burbank	240	AO91812-1	158
TX1673-2W/Y	235	AOTX97275-2Ru	151
COTX93032-1R	232	Morning Gold	150
NDC5281-2R	230	BTX1749-2Ru/Y	145
NDO4323-2R	227	TX1523-1Ru/Y	143
COTX90046-5W	225	CO92059-8W	141
COTX94216-1R	224	A90490-1	139
A90467-14	223	Atlantic	128
Shepody	223	ATX9202-3Ru	128
Stampede Russet	221	Dark Red Norland	127
NDTX4784-9R	220	TXNS102	125
COTX93053-4R	219	BTX1813-2R	120
BTX1810-3a	218	TX549-1Ru	119
AC91014-2Ru	211	AC89653-3W	108
Adora	207	A8792-1	104
AC87079-3Ru	207		
NDO4300-1	206		
COTX94218-1	206		
Russet Nugget	204		
COTX94016-2	203		
A90586-11	200		

TABLE 3-5 – ANOVA table for Field Day Trial 2000 samples.

Source	DF	Type III SS	MS	F-Value	Pr > F
Genotype	90	1725036.505	19167.072	8.86	<.0001
Replication	2	9178.963	4589.482	2.12	0.1229

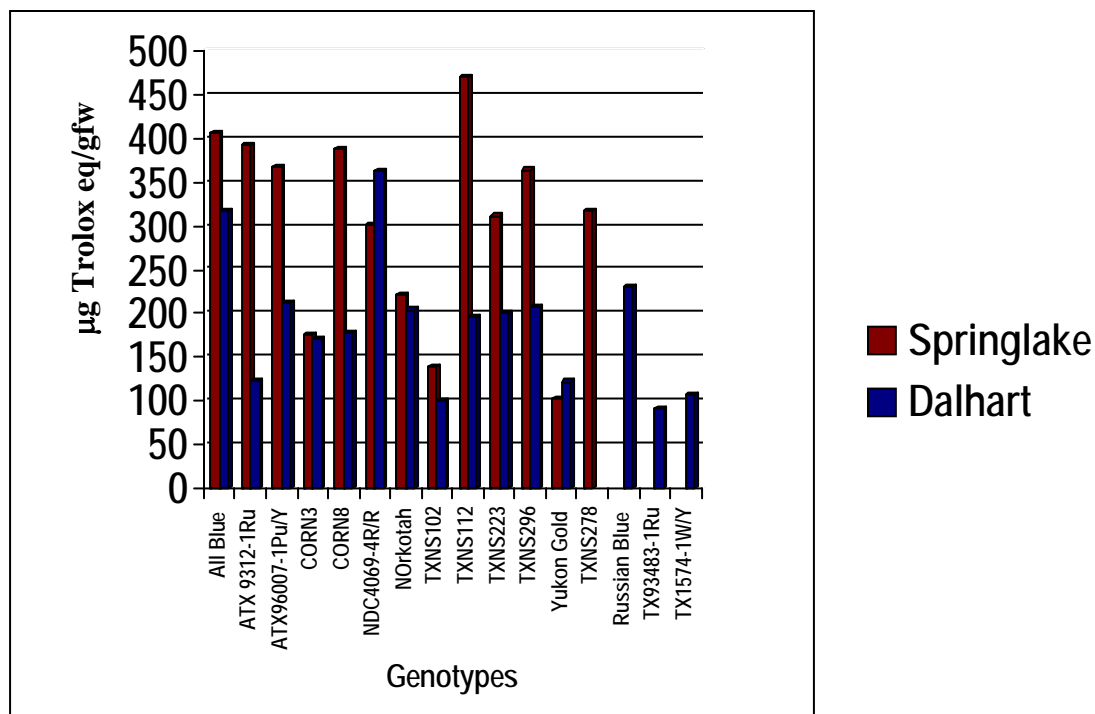


**FIGURE 3-2.**  
**Distribution of antioxidant activities for genotypes analyzed in**  
**Field Day Trial 2000.**



**FIGURE 3-3.**  
**Variation in antioxidant activity among Russet Norkotah and its intraclonal variants,**  
**Field Day Trial 2000.**

*Location Effect* - In 2000, six advanced selections and 11 named varieties were grown near Dalhart, Texas in order to compare the effect of location on antioxidant activity. In an analysis of variance, significant differences were found between varieties ( $p < .0001$ ) and locations ( $p < .0001$ ), but not replications ( $p = .0875$ ). Furthermore, significant interaction was found between variety and location ( $p < .0001$ ). The effect of location is consistent with previous reports by Hamouz *et al.* (1999a), who reported that, over a three year period, potatoes cultivated on loam soils in warm dry regions with low altitudes contained less total phenolics than those cultivated in cooler and more humid regions on sandy loam soil. Furthermore, it is known that tubers that are exposed to abiotic and biotic stresses increase their production of phenolics as a defense mechanism (Lewis *et al.* 1998b; Hamouz *et al.* 1999a). Since the conditions in the two locations are not identical, the location effect is not surprising. The tubers grown in Springlake, which tends to be a more stressful environment, were 1.6 times as high in antioxidant activity as those grown in Dalhart (Figure 3-4).



**Figure 3-4.**  
**Comparison of antioxidant activity from tubers grown in Springlake and Dalhart during the 2000 growing season.**

*Comparison of Potato Chips Using the DPPH Assay* – The seven types of potato chips were analyzed to determine antioxidant activity. Three replications were taken from each bag of chips. Significant differences were observed between some chip types ( $p=0.0473$ ), with Terra Blues significantly different from Bob’s Texas Style chips. Antioxidant activities were very low in the chips as compared to raw potatoes, ranging from 0-49 µg trolox equivalents/gfw. It is not known whether the low values for the chips were due to interaction of the oil with the DPPH assay, or if most of the antioxidant activity was lost during processing. Since some of the chips were treated with butylated hydroxytoluene, a synthetic antioxidant, reasonable levels of antioxidant activity in the chips were expected (Table 3-6).

TABLE 3-6 – *Antioxidant activity of 7 different brands of chips ranked by the DPPH assay.*

<b>Chips</b>	<b>µg trolox equivalents/gfw</b>	<b>Tukey's grouping</b>
Terra Blues	37	a
Zapps - salt and vinegar	12	ab
Tera Yukon Gold	4	ab
Wavy Lays	3	ab
Ruffles	0	ab
Kettle Chips	0	ab
Lays Wow Original	0	ab
Bobs Texas Style	0	b

*Comparison of Different Vegetables Using the DPPH Assay – Eighteen*

vegetables were analyzed for antioxidant activity. Significant differences ( $p < .0001$ ) were found between vegetables, with values ranging from 0-793 µg trolox equivalents/gfw. These same values, converted to µg ascorbic acid equivalents/gfw ranged from 0-752. No significant differences were detected between replications ( $p = .2858$ ). Leading the vegetables in antioxidant activity were green pepper, maroon carrot, and broccoli with values of 793, 560, and 511, respectively. Red-skinned potato fell below the top vegetables, with antioxidant activity equivalent to 126, and white skinned potato had an average value of 149 µg trolox equivalents/gfw. Potato was found to be significantly higher than celery in antioxidant activity, and fell in the same group as tomato, carrot, radish, yellow onion, romaine lettuce, white onion, yellow squash, green squash, and cucumber. The ranking of different vegetables, with their groupings from Tukey's HSD mean separation test, and their average antioxidant values is shown in Table 3-7.



TABLE 3-7 – *Antioxidant activities of 18 different vegetables ranked by the DPPH assay.*

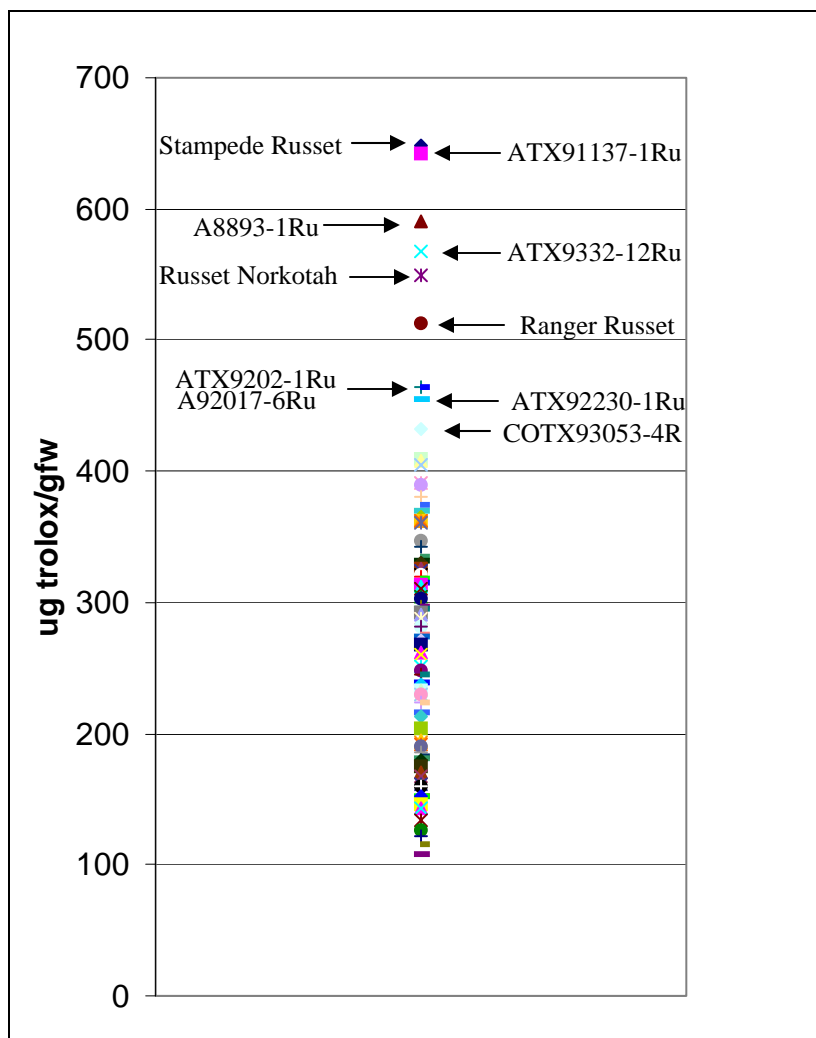
<b>Vegetable</b>	<b>µg trolox equivalents/gfw</b>	<b>Tukey's grouping</b>
Green Bell pepper	751	a
Maroon carrot	539	b
Broccoli	493	b
Spinach	292	b
Green onion	212	cd
Cabbage	196	cde
Tomato	177	cdef
White potato	152	cdef
Carrot	146	cdef
Red potato	130	cdef
Radish	109	cdef
Yellow onion	107	cdef
Romaine lettuce	94	def
White onion	58	def
Yellow squash	39	def
Zucchini	33	def
Cucumber	19	ef
celery	0	f

*Field Day Trial 2001* – A wide range of variation was observed in the 73 advanced selections and 27 named varieties analyzed in the 2001 Field Day Trial. Average antioxidant activity of genotypes ranged from 108-648 µg trolox equivalents/gfw, with an average value of 289. The same values converted to µg ascorbic acid equivalents/gfw ranged from 101-614, with an average value of 273. The antioxidant activities of advanced selections ranged from 108-642 µg trolox equivalents/gfw, while those of named varieties ranged from 146-648 (Table 3-8). There was a six-fold difference between the genotype which had the lowest antioxidant activity and that which was highest. Analysis of variance revealed significant differences between genotypes ( $p < .0001$ ), while replications were insignificant ( $p = .0982$ ). As in the

2000 Field Day Trial samples, Tukey's HSD revealed little about which genotypes would be best for use as parents, so the mean antioxidant activities for each genotype were graphed in order to visually observe the distribution (Figure 3-5). The graph revealed 10 genotypes that were above the rest of the cluster. These included Stampede Russet, ATX91137-1Ru, A8893-1Ru, ATX9332-12Ru, Russet Norkotah, Ranger Russet, ATX9202-1Ru, A92017-6Ru, ATX92230-1Ru, and COTX93053-4R. Again, Russet Norkotah and its intracloonal variants were analyzed separately from the rest of the genotypes. An analysis of variance showed a p-value of  $<.0001$  for genotypes, with no significant difference observed for replications ( $p=.6633$ ). The relative differences, however, were not the same as those observed in 2000, with Russet Norkotah significantly different from all other varieties. CORN8, TXNS296, CORN3, TXNS223, TXNS278, and TXNS249 were significantly different from TXNS102 and TXNS112. Interestingly, TXNS112 was ranked at the top of the Norkotah analysis for antioxidant activity in 2000, while in 2001 it had the lowest mean antioxidant activity.

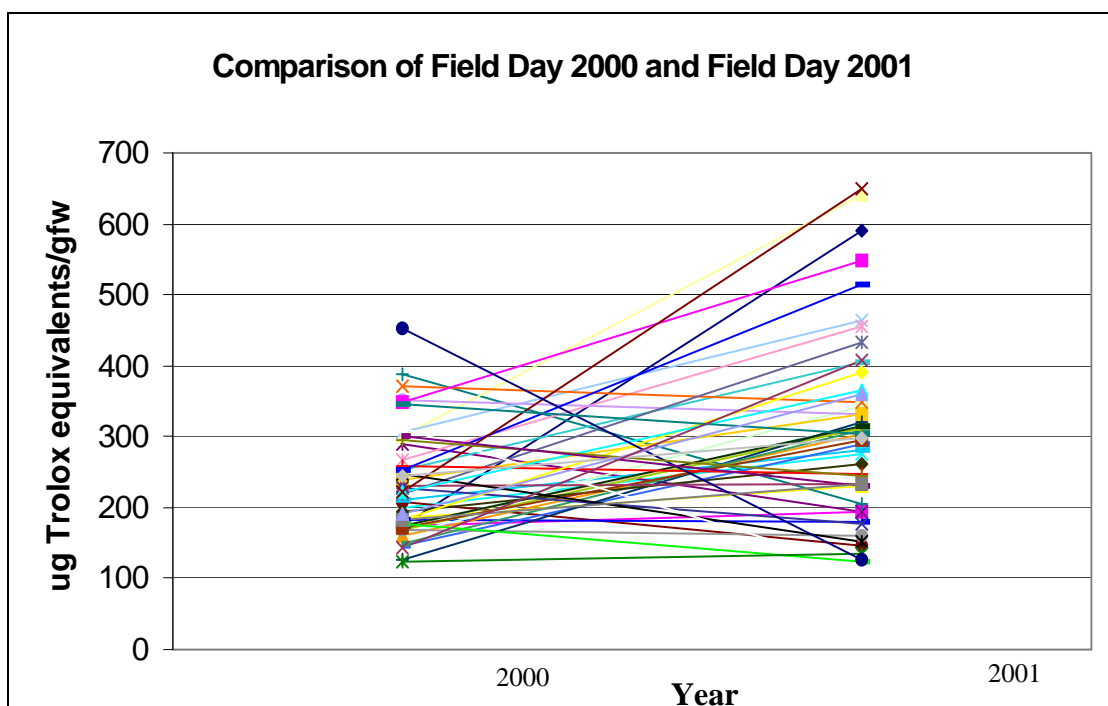
TABLE 3-8 - *Antioxidant activity of tubers grown in 2001.*

Genotype	µg Trolox eq/gfw	Genotype	µg Trolox eq/gfw
Stampede Russet	590	Yukon Gold	281
ATX91137-1Ru	568	A90586-11Ru	276
A8893-1Ru	549	ATTX83355-11R	275
ATX9332-12Ru	514	AOTX96458-1Ru	270
Russet Norkotah	464	AOTX96265-2Ru	269
Ranger Russet	464	MWTX2609-4Ru	262
ATX9202-1Ru	454	AC87079-3Ru	261
AO92017-6Ru	433	CO93032-1R	252
ATX92230-1Ru	409	NDTX5407-1R	247
COTX93053-4R	407	CO92027-2Ru	246
Mazama	406	TXNS223	246
TX1523-1Ru/Y	391	COTX4218-1R	239
BTX810-1R	390	ATX9302-1Ru	238
ATX96744-1R	380	NDC5281-2R	233
Red LaSoda	374	TX1385-12Ru	233
AOTX97164-1Ru	370	AOTX93483-1R	230
Sating	366	A9045-7Ru	230
ATX96746-1R	363	TXNS278	230
Shepody	362	CO93037-6R	224
CO92077-5Ru	362	ATTX83355-7R	224
ATX9332-8Ru	360	NDC5372-1Ru	216
Winema	348	TXNS249	213
TX1674-1 W/Y	343	All Blue	204
CORN 8	335	A9014-2Ru	195
ATX84706-2Ru	332	AC87138-4Ru	193
BTX1754-1W/Y	331	AC92009-4Ru	192
Russet Burbank	326	NDTX4271-5R	190
ATX961007-1	326	TC1675-1Ru	186
AOTX97175-4Ru	325	AOTX97213-1Ru	183
ATTX82700-12R	321	AC89536-5Ru	181
NDTX4790-1Ru	321	MSE192-8Ru	180
Dark Red Norland	319	NDO4323-2R	176
AOTX95156-4Ru	318	Platina	170
Ilong	316	A92584-3BB	167
ATX82539-4Ru	313	NDTX4898-1Ru	162
MWTX2609-2Ru	313	AOTX97130-1Ru	161
BTX1544-2W/Y	311	COTX95111-1R	160
BTX810-2Ra	310	NDTX4828-7R	153
ATX84378-1Ru	305	MSE202-3Ru	152
Morning Gold	303	NDTX4784-7R	152
TXNS296	297	Adora	146
CORN3	297	TDA99-1Ru	143
Vivaldi	296	AF1753-16Ru	143
AOTX91861-4R	293	TXNS102	134
MWTX 548-2Ru	292	TXNS112	127
ATX97232-1Ru	290	NDTX5438-11R	122
Latona	288	NDTX4828-2R	116
COTX4216-1R	287	NDTX4304-1R	108
BTX1749-2Ru/Y	282		
AOTX97287-1Ru			
AC91014-2Ru			



**FIGURE 3-5.**  
Antioxidant activities of genotypes analyzed in 2001.

*Effect of Year on Antioxidant Activity* – Thirty-one advanced selections and 18 named varieties were analyzed from both the 2000 and 2001 Field Day Trials. Analysis of variance revealed significant differences between genotype ( $p < .0001$ ), year ( $p < .0001$ ), and the genotype x year interaction ( $p < .0001$ ), with no significant differences between replications ( $p < .2614$ ) (Table 3-9). A graph of the data reveals that, of the 47 genotypes analyzed, 32 increased in antioxidant activity between 2000 and 2001, and 15 decreased (Figure 3-6). The genotypes that decreased in antioxidant activity had an average decrease of 27%, while those increasing in activity had an average increase of 85% (Table 3-10). The genotype with the largest difference between years was A8893-1 (240% increase).



**FIGURE 3-6.** Comparison of Field Day data for antioxidant activity across 2 growing seasons reveals a significant interaction between year and genotype. Thirty-two genotypes showed an increase in antioxidant activity while 15 showed a decrease between 2000 and 2001.

TABLE 3-9 – ANOVA table for comparison of antioxidant activity of tubers grown in 2000 and 2001.

<b>Source</b>	<b>DF</b>	<b>Type I SS</b>	<b>MS</b>	<b>F-value</b>	<b>Pr&gt;F</b>
Variety	53	1729821.847	32638.148	7.16	<.0001
Year	1	517532.562	517532.562	113.51	<.0001
Variety*Year	44	1356923.430	30839.169	6.76	<.0001
Replication	2	12322.985	6161.493	1.35	0.2614
Error	187	852581.860			

TABLE 3-10 – *Comparison of antioxidant activities from Field Day Trials 2000 and 2001.*

<b>Genotype</b>	<b>µg Trolox/gfw 2000</b>	<b>µg Trolox/gfw 2001</b>	<b>Increase/Decrease</b>	<b>% Difference</b>
A8893-1	174	590	240	increase
A9014-2	175	195	11	increase
A9045-7Ru	186	230	24	increase
AC87138-4Ru	289	193	-33	decrease
AC89536-5Ru	184	181	-1	decrease
AC91014-2Ru	211	282	34	increase
Adora	207	146	-29	decrease
AllBlue	389	204	-47	decrease
ATX82539-4Ru	162	318	96	increase
ATX84706-2Ru	169	343	102	increase
ATX91137-1Ru	301	642	113	increase
ATX9202-1Ru	306	464	52	increase
ATX92230-1Ru	267	454	70	increase
BTX1544-2W/Y	173	313	80	increase
BTX1749-2Ru/Y	145	288	98	increase
BTX1810-1R	252	406	61	increase
BTX1810-2Ra	169	313	85	increase
CORN3	161	303	88	increase
CORN8	370	348	-6	decrease
COTX93053-4R	219	433	98	increase
COTX95111-1R	169	160	-5	decrease
Dark Red Norland	127	321	152	increase
Morning Gold	150	310	106	increase
MWTX2609-2Ru	173	316	82	increase
MWTX2609-4Ru	195	262	34	increase
MWTX548-2Ru	172	296	72	increase
NDC5281-2R	230	233	1	increase
NDO4323-2R	227	176	-23	decrease
NDTX4784-7R	247	152	-38	decrease
NDTX4828-2R	313	116	-63	decrease
NDTX5407-1R	260	247	-5	decrease
NDTX5438-11R	176	122	-30	decrease
Ranger Russet	254	514	102	increase
Red LaSoda	181	390	115	increase
Russet Burbank	240	332	38	increase
Russet Norkotah	347	549	58	increase
Shepody	223	366	64	increase
Stampede Russet	221	648	193	increase
TX1385-12Ru	182	233	28	increase
TX1523-1Ru/Y	143	407	186	increase
TX1674-1W/Y	192	360	87	increase
TXNS102	125	134	7	increase
TXNS112	452	127	-72	decrease
TXNS223	295	246	-17	decrease
TXNS278	301	230	-24	decrease
TXNS296	346	305	-12	decrease
Vivaldi	245	297	21	increase

Since there were genotype x environment interactions, it was interesting to observe which genotypes performed well in both 2000 and 2001. To estimate which genotypes performed well in both years, rankings were given to each genotype. If a genotype was the highest in antioxidant activity, it received a ranking of one, if it was the second highest, two, etc. Rankings for both years were added together for each genotype, and those with the lowest number were considered to be consistently high in carotenoid content and of interest to the breeding program. These genotypes, in order of ranking were Russet Norkotah, ATX91137-1Ru, ATX9202-1Ru, CORN8, Ranger Russet, ATX92230-1Ru, Stampede Russet, BTX1810-1R, TXNS296, and COTX93053-4R.

#### ***HPLC Analysis of Phenolic Compounds***

Based on the results of the DPPH analysis, the top 10% of genotypes in antioxidant activity were analyzed, in triplicate, via HPLC. At the beginning of this study, HPLC analysis of phenolics was not anticipated, thus only the Field Day 2001 genotypes were included in this analysis. These genotypes included Stampede Russet, ATX91137-1Ru, ATX8893-1Ru, ATX9332-12Ru, Russet Norkotah, Ranger Russet, ATX9202-1Ru, AO92017-6R, ATX92230-1Ru, COTX93053-4R, and Mazama. As in previous studies, the primary phenolics identified in the tubers were chlorogenic and caffeic acids, with minor amounts of rutin hydrate. Chlorogenic acid levels ranged from 26-341  $\mu\text{g/gfw}$ , but with the minimum significant difference of 494  $\mu\text{g/gfw}$  for Tukey's studentized range test, no significant differences between genotypes were observed ( $p=0.1547$ ). This is consistent with values reported by Dao and Freidman (1992), who reported chlorogenic acid concentrations ranging from 97-187  $\mu\text{g/g}$ . Caffeic acid levels ranged from 33-41  $\mu\text{g/gfw}$ . Significant differences were found between varieties at the

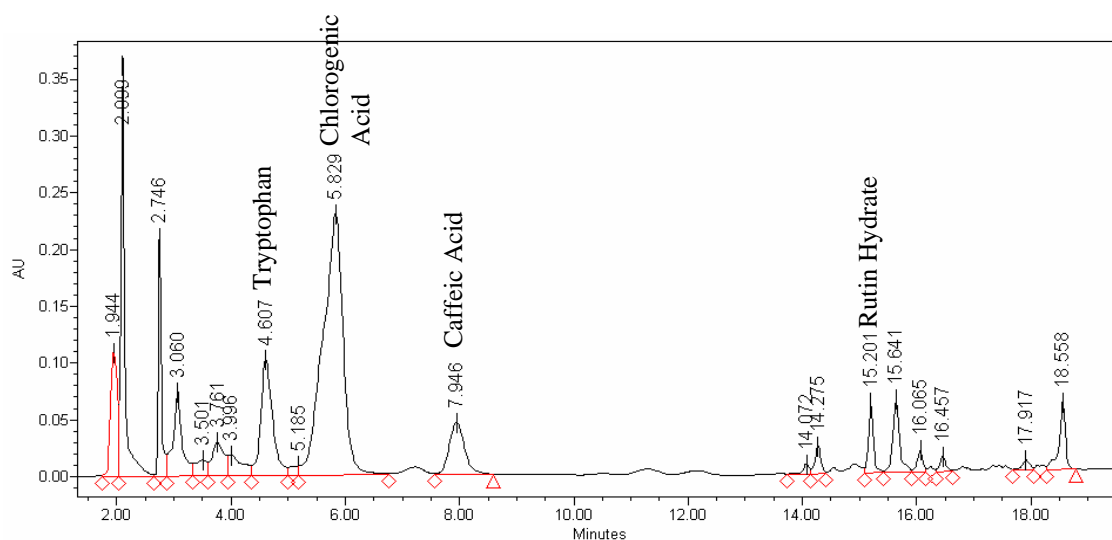


$\alpha=0.05$  level ( $p=0.0203$ ), while reps were insignificant ( $p=0.7040$ ). These values are above those reported by Yamamoto *et al.* (1997) who reported a caffeic acid concentration between 0.2-3.2  $\mu\text{g/gfw}$ . ATX9202-1Ru was found to be significantly different from COTX93053-4R. No other significant differences were observed. Rutin hydrate levels ranged from 7  $\mu\text{g/gfw}$  in Mazama to 306  $\mu\text{g/gfw}$  in Ranger Russet. Significant differences were observed between genotypes ( $p<0.0001$ ), but not between replications ( $p=0.5561$ ). Ranger Russet was found to be significantly different from all other genotypes analyzed. The high levels of rutin hydrate make it an interesting candidate for crossing since no other genotypes contained levels nearly this high. Tryptophan was observed in all samples subjected to HPLC, but was not quantitated. Total phenolics were calculated by adding each of the individual components together. They ranged from 60-394  $\mu\text{g/gfw}$ ; however, no significant differences were observed between genotypes (Table 3-11). The range of values is equal to or higher than those reported by Rodriguez de Sotillo *et al.* (1994) (321  $\mu\text{g/gfw}$ ), Lewis *et al.* (1998b) (157  $\mu\text{g/gfw}$ ), and Hamouz *et al.* (1996b) (36-85-52.89  $\mu\text{g/gfw}$ ). The lack of significance could be explained by the fact that only the top varieties were analyzed from the screen for antioxidant activity. Had the entire range of antioxidant activities been analyzed, there is little doubt that significant differences between genotypes would have been observed. A typical chromatogram (Ranger Russet) is shown in Figure 3-7. Although there were peaks observed other than tryptophan, chlorogenic acid, caffeic acid, and rutin hydrate, and they sometimes matched retention times with the standards analyzed, none of the spectra in the library matched these peaks.

A correlation analysis was performed between the results from the DPPH assay and the total phenolics as quantitated via HPLC analysis. Pearson's correlation coefficient was calculated as 0.43, and linear regression revealed that only 18% of the variability in the DPPH analysis could be explained by total phenolic content. The discrepancy between these two analyses could be explained by at least two factors. The first of these is that the DPPH assay accounts for the total antioxidant activity of the methanol extract, and there are antioxidants other than phenolics present in this extract. Thus, the estimated antioxidant activity probably involved more than just the phenolics analyzed via HPLC. Secondly, in the HPLC analysis, there were large peaks that remain unidentified. As is clear from the chromatogram shown in Figure 3-7, significant peaks were not quantitated due to the lack of a spectral match in the library of 19 phenolics used. These unidentified peaks, possibly phenolic glycosides, could have antioxidant activity, which contributes to the total antioxidant activity calculated in the DPPH assay.

TABLE 3-11 – *Phenolic compounds identified via HPLC in 2001 Field Day Trial samples.*

<b>Genotype</b>	<b>Caffeic Acid µg/gfw</b>	<b>Chlorogenic Acid µg/gfw</b>	<b>Rutin Hydrate µg/gfw</b>	<b>Total Phenolics µg/gfw</b>	<b>DPPH</b>	
Russet Norkotah	36	329		29	394	549
ATX9202-1	42	341		9	391	464
Ranger Russet	36	39		306	380	514
ATX9332-12Ru	38	304	Not detected		342	590
ATX91137-1Ru	37	286	Not detected		323	642
Stampede Russet	38	270		14	322	648
AO92017-6R	35	217		14	266	464
Mazama	34	122		7	163	409
ATX92230-1R	35	112	Not detected		146	454
A8893-1Ru	35	82		14	131	590
COTX93053-4R	33	26	Not detected		60	433



**FIGURE 3-7.**  
**A representative chromatogram of the separation of phenolics in Field Day Trial 2001 samples via HPLC.**

### ***Broad Screen for Carotenoid Content***

*Standard Curves for Lutein and  $\beta$ -carotene* – Spectrophotometric readings for the ethanol samples at 445 nm were converted into lutein equivalents based on the following equation:  $y = 3028.6x + 8.1063$ , where  $x$  = absorbance at 445nm and  $y$  =  $\mu\text{g}$  lutein equivalents/100gfw. The  $R^2$  value for this curve was 0.9991. Hexane samples were analyzed at 450 nm and converted into  $\beta$ -carotene equivalents with the following equation:  $y = 373.59x + 2.0463$ , where  $x$  = absorbance at 450nm, and  $y$  =  $\mu\text{g}$   $\beta$ -carotene equivalents/100gfw. The  $R^2$  value for this equation was 0.9993. The values reported in the subsequent discussion on the broad screen of carotenoids are based on the aforementioned equations.

*Field Day Trial 2000* – A wide range of variation in carotenoid content was observed in the 67 advanced selections and 24 named varieties analyzed in the 2000 Field Day Trial. Micrograms of lutein equivalents ranged from 85-310  $\mu\text{g}/100\text{gfw}$ , with an

average value of 184, while average values of  $\beta$ -carotene equivalents ranged from 3-59  $\mu\text{g}/100\text{gfw}$ , with an average value of 14. Total carotenoid content was estimated by adding together the lutein and  $\beta$ -carotene equivalents, and was found to range from 94-367  $\mu\text{g}/100\text{gfw}$ . Analysis of variance revealed significant differences between genotypes ( $p < .0001$ ), while replications were insignificant ( $p = 0.4697$ ). A four-fold difference was observed between the genotype with the lowest total carotenoid content and that with the highest (Table 3-12). Due to the number of genotypes analyzed, a graphical representation was deemed the most appropriate for identifying parents for use in future crosses. The mean total carotenoid content of each genotype based on the absorbance of the extracts at 445 and 450, was graphed, and revealed 11 genotypes, which fell above the rest of the cluster (Figure 3-8). These genotypes included ATX82539-4Ru, Chipeta, TX1674-1W/Y, CORN8, NDTX4784-7R, NDTX5067-2R, BTX1810-3a, Dark Red Norland, Purple Peruvian, CORN3, and Russet Burbank. While it was expected that the yellow flesh variety TX1674-1W/Y would be among the top entries, it was surprising that the other yellow flesh varieties were not. Despite falling in the cluster with the varieties with lower carotenoid content, differences were not statistically significant from the 11 varieties listed above. When analyzed separately from the rest of the data, significant differences were found between Russet Norkotah and its intracloonal variants. An analysis of variance revealed significant differences between genotypes ( $p = .0015$ ), while no differences were noted between replications ( $p = .9678$ ). CORN8 lead the Russet Norkotah variants with a total carotenoid content of 307  $\mu\text{g}$  carotenoid equivalents/100gfw. CORN8, while not significantly different from CORN3 or TXNS223, was different from TXNS112, TXNS102, TXNS296, TXNS278, and Russet

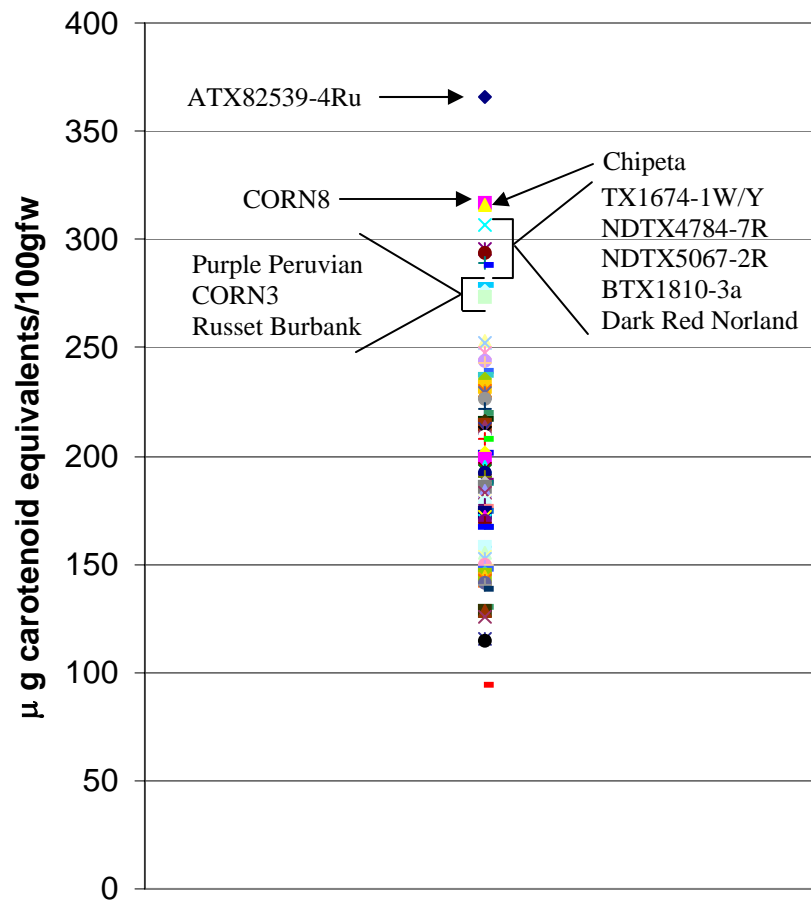
Norkotah. Furthermore, CORN3 was significantly different from TXNS278 and Russet Norkotah (Figure 3-9). No significant differences were observed between the hexane fractions of the Russet Norkotah genotypes ( $p=0.8925$ ); however differences were observed in the lutein fraction ( $p=0.0011$ ).

TABLE 3-12 – *Carotenoid content of genotypes analyzed from the 2000 Field Day Trial.*

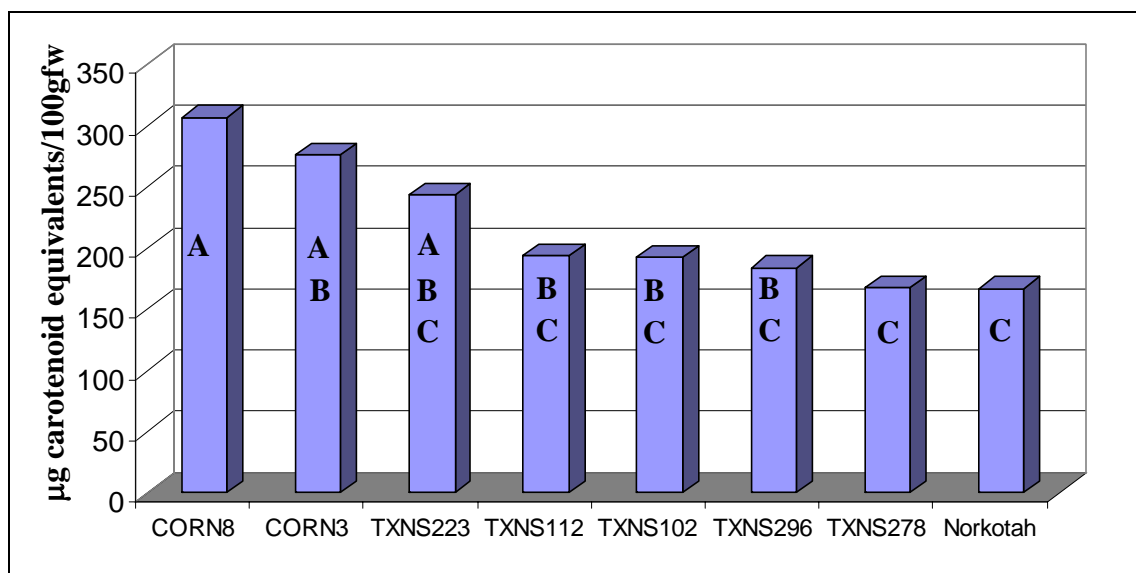
<b>Genotype</b>	<b>µg luteineq/100gfw</b>	<b>µg β-carotene eq/100gfw</b>	<b>Total µg carotenoids/100gfw</b>
ATX82539-4Ru	310	56	366
Chipeta	296	21	317
TX1674-1W/Y	289	26	316
CORN8	299	8	307
NDTX4784-7R	288	7	295
NDTX5067-2R	284	10	294
BTX1810-3a	282	8	289
Dark Red Norland	280	8	288
Purple Peruvian	271	8	279
CORN3	270	6	276
Russet Burbank	256	18	273
BTX1813-2R	245	9	253
TX1673-2W/Y	241	11	252
BTX1810-2a	241	10	248
A90490-1	244	Missing data	244
TXNS223	234	9	243
NDO4588-5	235	3	239
A90467-14	237	Missing Data	237
CherryRed	228	7	235
BTX1810-1	224	8	232
BTX1544-2W/Y	191	39	230
NDTX4784-1R	219	11	230
ATX9312-1Ru	197	32	229
ATX96007-1P/Y	167	59	226
Stampede Russet	217	5	222
CO92059-8W	211	8	220
BTX1749-1Ru/Y	178	39	217
NDTX4828-2R	204	9	216
NDTX4784-9R	204	10	214
Ranger Russet	203	11	213
COTX90046-5W	208	4	212
ATX84706-2Ru	193	17	210
TX1523-1Ru/Y	188	20	208
Vivaldi	197	11	208
ATX91137-1Ru	178	23	202
NDO4323-2R	196	5	201
AC87138-4Ru	195	8	199

TABLE 3-12 – *continued*

<b>Genotype</b>	<b>µg luteineq/100gfw</b>	<b>µg β-carotene eq/100gfw</b>	<b>Total µg carotenoids/100gfw</b>
TXNS112	185	9	194
TXNS102	182	11	193
MWTX4241-1W	184	8	192
TXA549-1Ru	182	8	190
AllBlue	180	12	189
COTX90046-5W	208	4	212
ATX84706-2Ru	193	17	210
NDTX8-731-1R	197	12	209
TX1523-1Ru/Y	188	20	208
Vivaldi	197	11	208
ATX91137-1Ru	178	23	202
NDO4323-2R	196	5	201
AC87138-4Ru	195	8	199
NDC5281-2R	191	3	195
TXNS112	185	9	194
TXNS102	182	11	193
MWTX4241-1W	184	8	192
TXA549-1Ru	182	8	190
All Blue	180	12	189
Morning Gold	163	24	188
A9045-7	181	6	187
BTX1749-2Ru/Y	174	12	186
TXNS296	171	14	184
A92657-1R	183	Missing Data	183
NDO4300-1	174	5	179
COTX93068-1R	166	13	179
MWTX2609-2Ru	171	7	178
AOTX97275-2Ru	155	21	177
NDC4069-4R/R	169	5	174
AC90636-3Ru	141	33	174
ATX9202-1Ru	153	21	173
MWTX2609-4Ru	151	21	172
TXDH99-1Ru	146	25	171
AC87079-3Ru	145	27	170
Red LaSoda	163	7	170
COTX93032-1R	164	5	169
TXNS278	161	6	168
Russet Norkotah	161	6	167
Shepody	153	5	158
ATX9202-3Ru	166	19	158
AC89536-5Ru	135	20	155
MWTX548-2Ru	148	5	153
NDTX4930-5W	146	6	152
COTX94216-1R	140	9	149
COTX93053-4R	138	10	148
AC91365-1Ru	129	19	148
A8893-1	142	14	148



**FIGURE 3-8.**  
Total carotenoid content of genotypes harvested in 2000.



**FIGURE 3-9.**  
**Comparison of total carotenoid content of Russet Norkotah and its intraclonal variants.**

*Field Day Trial 2001* - A wide range of variation in carotenoid content was observed in the 73 advanced selections and 27 named varieties analyzed in the 2001 Field Day Trial. Micrograms of lutein equivalents ranged from 91-482 µg/100gfw, with an average value of 183, and β-carotene equivalents ranged from 5-66 µg/100gfw, with an average value of 18. Total carotenoid content, estimated by adding together the lutein and B-carotene equivalents, was found to range from 97-536 µg/100gfw, with an average value of 195. Analysis of variance revealed significant differences between genotypes ( $p < 0.0001$ ), while replications were insignificant ( $p = 0.3426$ ). A six-fold difference was observed between the genotype with the lowest total carotenoid content (TDA99-1Ru), and the genotype with the highest (TX1674-1W/Y) (Table 3-13). Analysis of the ethanol extract revealed significant differences between the genotypes in lutein equivalents ( $p < 0.0001$ ), while replications were insignificant ( $p = 0.1395$ ). In the analysis of the hexane extract, both genotype and replication were significant ( $p < 0.0001$ , and  $p = 0.0003$ ,



respectively). Due to the large number of genotypes analyzed, the data was graphed, and genotypes falling above the cluster were considered to be of interest in the breeding program. Genotypes of interest include TX1674-1W/Y, Yukon Gold, BTX1544-2W/Y, BTX1749-2Ru/Y, BTX1754-1W/Y, ATX9202-1Ru, Latona, and ATX961007-1Pu/Y (Figure 3-10). Unlike the 2000 Field Day Trial, in 2001, most of the yellow flesh varieties analyzed were among the highest in carotenoid content.

Once again, significant differences were observed between Russet Norkotah and its intracloonal variants. When total carotenoid content was analyzed separately, an analysis of variance revealed genotype to be significant at the  $\alpha=.05$  level ( $p=.0189$ ), while replications were insignificant ( $p=.6890$ ). CORN8 was shown to be significantly different from TXNS223. No other significant differences were observed in total carotenoid content. When the hexane extract was analyzed, analysis of variance showed significant differences in  $\beta$ -carotene equivalents between both genotype ( $p<.0001$ ) and replications ( $p=.0024$ ). The lutein extract revealed significant differences at the  $\alpha=.05$  level between genotypes ( $p=.0273$ ) but not between replications ( $.5952$ ).

TABLE 3-13 – *Carotenoid content of genotypes analyzed from the 2001 Field Day Trial.*

<b>Genotype</b>	<b>µg Lutein/100gfw</b>	<b>µg β-carotene/100gfw</b>	<b>Total µg carotenoid/100gfw</b>
TX1674-1 W/Y	483	53	536
Yukon Gold	419	37	457
BTX1544-2W/Y	372	58	430
BTX1749-2Ru/Y	339	53	392
BTX1754-1W/Y	334	47	381
ATX9202-1Ru	289	35	363
Latona	328	33	361
ATX961007-1	304	43	347
CORN8	282	27	308
ATX91137-1Ru	243	66	296
Ilong	264	31	296
TXNS296	271	11	282
NDTX4898-1Ru	278	8	281
TX1523-1Ru/Y	238	40	277
CORN 3	247	23	271
Vivaldi	230	40	270
ATX9202-3Ru	258	8	263
BTX810-2Ra	221	34	256
AOTX97287-1Ru	226	11	237
ATX9332-8Ru	228	7	236
ATX97232-1Ru	204	28	233
Winema	214	12	226
Russet Norkotah	200	16	216
Sating	174	31	205
BTX810-1R	181	21	201
ATX96744-1R	186	13	200
Stampede Russet	189	7	196
ATX82539-4Ru	179	16	195
CO92077-5Ru	182	11	193
NDTX4271-5R	184	8	192
ATX84706-2Ru	206	51	190
COTX4216-1R	291	13	187
NDTX4790-1Ru	176	8	184
NDTX5438-11R	174	8	182
A9014-2Ru	165	24	181
Ranger Russet	175	6	181
NDO4323-2R	166	12	178
Platina	155	23	178
COTX4218-1R	171	6	177
AC87079-3Ru	172	14	177
Morning Gold	147	22	175
NDTX5407-1R	167	8	175
TXNS112	163	9	172

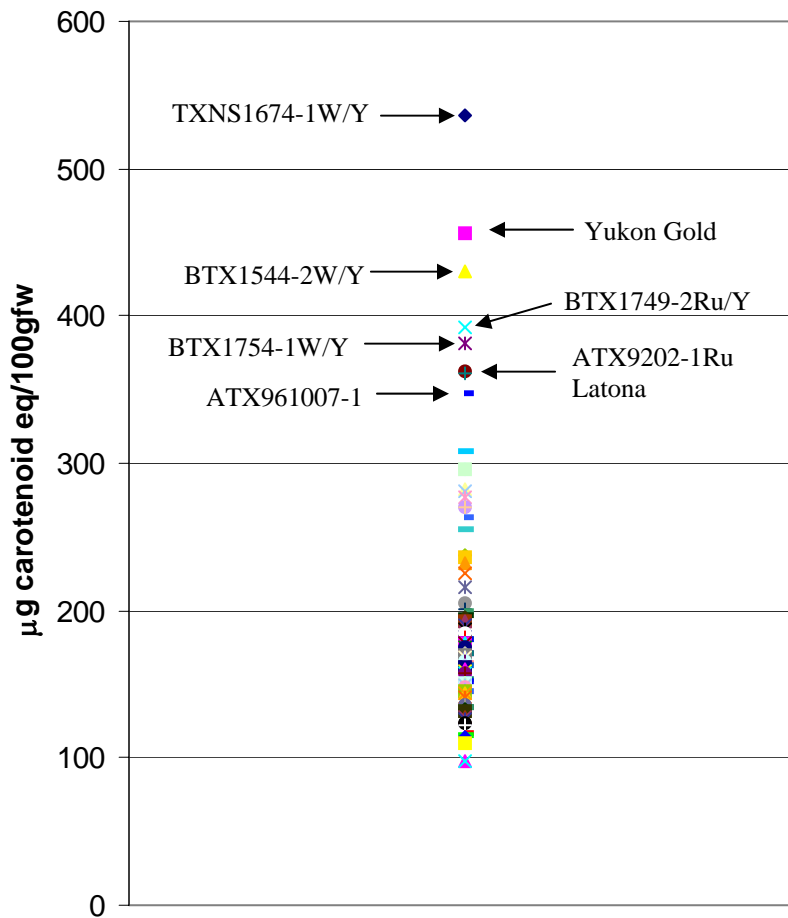
TABLE 3-13 - *continued*

<b>Genotype</b>	<b>µg Lutein/100gfw</b>	<b>µg β-carotene/100gfw</b>	<b>Total µg carotenoid/100gfw</b>
ATTX83355-7R	160	12	171
AOTX95156-4Ru	155	16	171
NDTX4828-7R	160	10	171
AC87138-4Ru	136	33	169
ATTX83355-11R	157	12	169
COTX93032-1	162	6	169
Russet Burbank	154	15	168
TXNS249	157	9	166
ATX84378-1Ru	147	19	166
AOTX93483-1R	145	19	164
A92584-3BB	151	28	163
A9045-7Ru	141	31	163
TXNS102	153	9	162
CO92027-2Ru	144	16	160
TXNS278	153	6	159
MWTX548-2Ru	147	11	158
Red LaSoda	142	16	158
AOTX 97213-1Ru	140	17	157
Shepody	140	13	153
MWTX2609-4Ru	141	10	152
A8893-1Ru	132	20	151
COTX95111-1R	143	8	151
A90586-11Ru	143	8	150
NDC5281-2R	141	8	150
Dark Red Norland	137	12	149
AOTX97175-4Ru	138	11	148
NDC5372-1Ru	140	7	147
COTX93053-4R	137	8	145
NDTX4828-2R	134	11	145
ATX9302-1Ru	135	10	145
A92657-1R	138	7	145
AOTX97130-1Ru	129	15	143
AOTX97164-1Ru	129	15	143
ATTX82700-12R	127	14	141
ATX 9332-12Ru	129	7	136
NDTX4784-7R	129	7	136
AOTX96265-2Ru	115	19	135
TX1385-12Ru	123	11	134
MWTX2609-2Ru	121	10	132
Mazama	116	16	131
AC87079-3Ru	104	24	128
CO93037-6R	115	12	127
TXNS223	119	7	126
TC1675-1Ru	114	9	123

TABLE 3-13 - *continued*

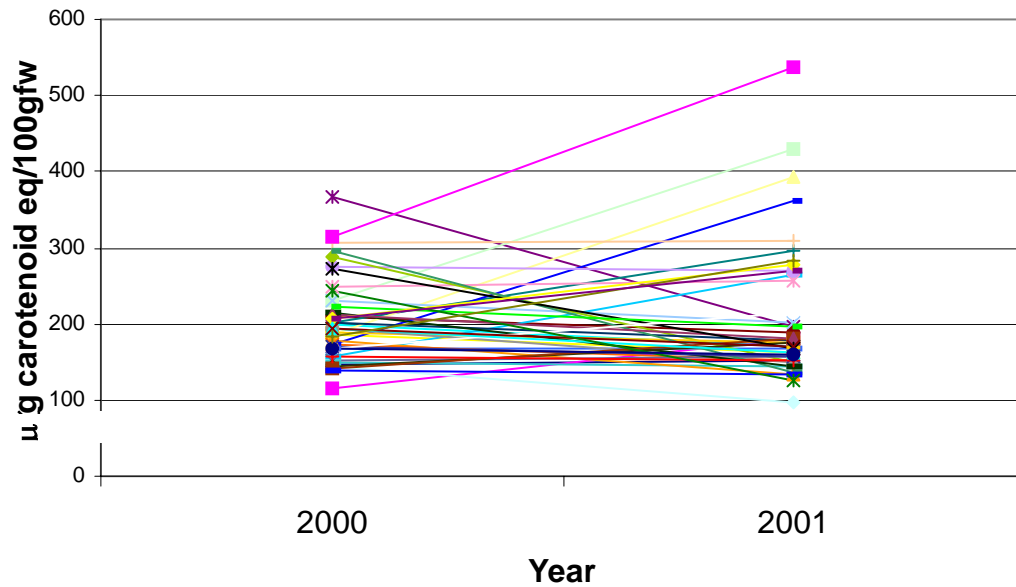
Genotype	$\mu\text{g}$ Lutein/100gfw	$\mu\text{g}$ $\beta$ -carotene/100gfw	Total $\mu\text{g}$ carotenoid/100gfw
MSE192-8Ru	115	7	123
TDA99-1Ru	112	5	117
AOTX96458-1Ru	96	20	115
MSE202-3Ru	107	7	114
ATX96746-1R	102	8	110
ATX92230-1Ru	91	7	98
NDTX4304-1R	92	6	97

### Total Carotenoid Content of Genotypes Harvested in 2001



**FIGURE 3-10.**  
The carotenoid content of genotypes harvested in Field Day Trial 2001.

*Effect of Year on Carotenoid Content* –Forty-four genotypes were analyzed for carotenoid content from both the 2000 and 2001 Field Day Trials. Analysis of variance revealed significant differences between genotypes ( $p < 0.0001$ ) and genotype by year interaction ( $p < 0.0001$ ), but not between years ( $p = 0.9113$ ) or replications ( $p = 0.7639$ ) (Table 3-14). A graph of the data reveals that, of the 44 genotypes analyzed, 17 increased in carotenoid content between 2000 and 2001, and 27 decreased (Figure 3-11). The genotypes that increased in carotenoid content had an average increase of 44%, while those decreasing in carotenoid content had an average decrease of 19% (Table 3-15). The genotype with the largest difference between years was BTX1749-2Ru/Y (111% increase). Since there were genotype x year interactions, it was interesting to observe which genotypes performed well both years. Determining percent change is interesting and calculating averages across years was informative, however, relative ranking among other genotypes was of more interest than were absolute values. To estimate which genotypes performed well in different years, rankings were given for genotypes analyzed in both 2000 and 2001. If a genotype was the highest in carotenoid activity, it received a ranking of one, if it was second highest, a two, etc. Rankings from both years were added together for each genotype, and those with the lowest number were considered to be consistently high in carotenoid content and of interest to the breeding program. These genotypes, in order of ranking, included TX1674-1W/Y, BTX1544-2W/Y, CORN8, BTX1749-2Ru/Y, ATX9202-1Ru, ATX91137-1Ru, TXNS296, Vivaldi, and CORN3.



**FIGURE 3-11.**  
**Comparison of total carotenoid content for Field Day Trial 2000 and 2001.**

TABLE 3-14 – ANOVA table for comparison of total carotenoid content of tubers grown in 2000 and 2001.

Source	DF	Type III SS	MS	F-Value	Pr>F
Variety	51	872641.3265	17110.6142	9.92	<.0001
Year	1	21.4782	21.4782	0.01	0.9113
Variety*Year	43	420388.5182	9776.4772	5.67	<.0001
Replication	2	930.9008	465.4504	0.27	0.7639
Error	162	279505.827	1725.345		

TABLE 3-15 – Comparison of total carotenoid content from Field Day Trial 2000 and Field Day Trial 2001.

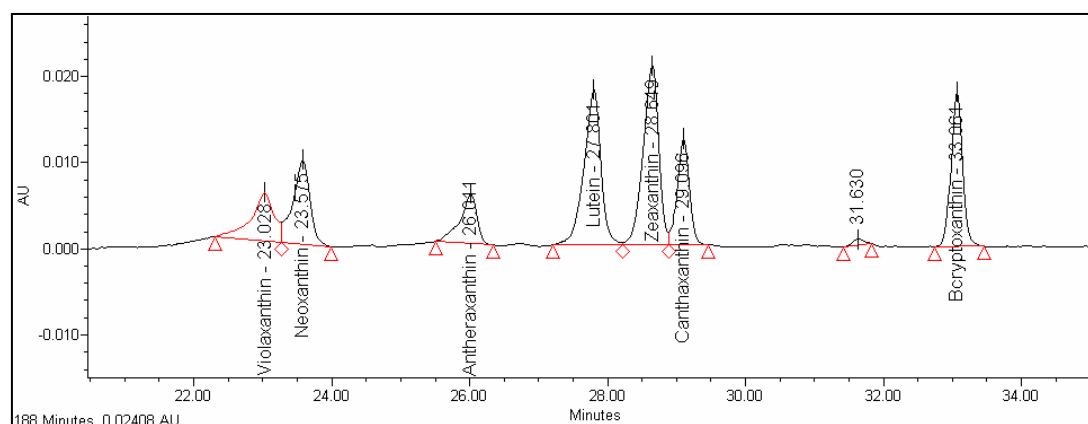
Genotype	µg carotenoid eq/100gfw		Change	Difference (%)
	2000	2001		
A8893-1	148	151	increase	2
A9014-2	115	181	increase	58
A9045-7Ru	187	163	decrease	-13
AC87138-4Ru	199	169	decrease	-15
ATX82539-4Ru	366	195	decrease	-47
ATX84706-2Ru	210	190	decrease	-10
ATX91137-1Ru	202	296	increase	47
ATX9202-1Ru	173	363	increase	109
ATX9202-3Ru	158	263	increase	67
ATX92230-1Ru	144	98	decrease	-32
BTX1544-2W/Y	230	430	increase	87
BTX1749-2Ru/Y	186	392	increase	111
BTX1810-1R	232	201	decrease	-13
BTX1810-2Ra	248	256	increase	3
CORN3	276	271	decrease	-2
CORN8	307	308	increase	0
COTX93032-1R	169	169	increase	0
COTX93053-4R	148	145	decrease	-2
Dark Red Norland	288	149	decrease	-48
Morning Gold	188	175	decrease	-7
MWTX2609-2Ru	178	132	decrease	-25
MWTX2609-4Ru	172	152	decrease	-12
MWTX548-2Ru	153	158	increase	3
NDC5281-2R	195	150	decrease	-23
NDO4323-2R	201	178	decrease	-12
NDTX4784-7R	295	136	decrease	-54
NDTX4828-2R	216	145	decrease	-33
NDTX5407-1R	145	175	decrease	21
NDTX5438-11R	142	182	increase	28
Ranger Russet	213	181	decrease	-15
Red LaSoda	170	158	decrease	-7
Russet Burbank	273	168	decrease	-38
Russet Norkotah	167	216	increase	29
Shepody	158	153	decrease	-3
Stampede Russet	222	196	decrease	-12
TX1385-12Ru	139	134	decrease	-3
TX1523-1Ru/Y	208	277	increase	33
TX1674-1W/Y	316	536	increase	70
TXNS102	193	162	decrease	-16
TXNS112	194	172	decrease	-12

TABLE 3-15 – *continued*

Genotype	$\mu\text{g}$ carotenoid eq/100gfw		Change	Difference (%)
	2000	2001		
TXNS223	243	126	decrease	-48
TXNS278	168	159	decrease	-5
TXNS296	184	282	increase	53
Vivaldi	208	270	increase	30

### HPLC Analysis of Carotenoid Compounds

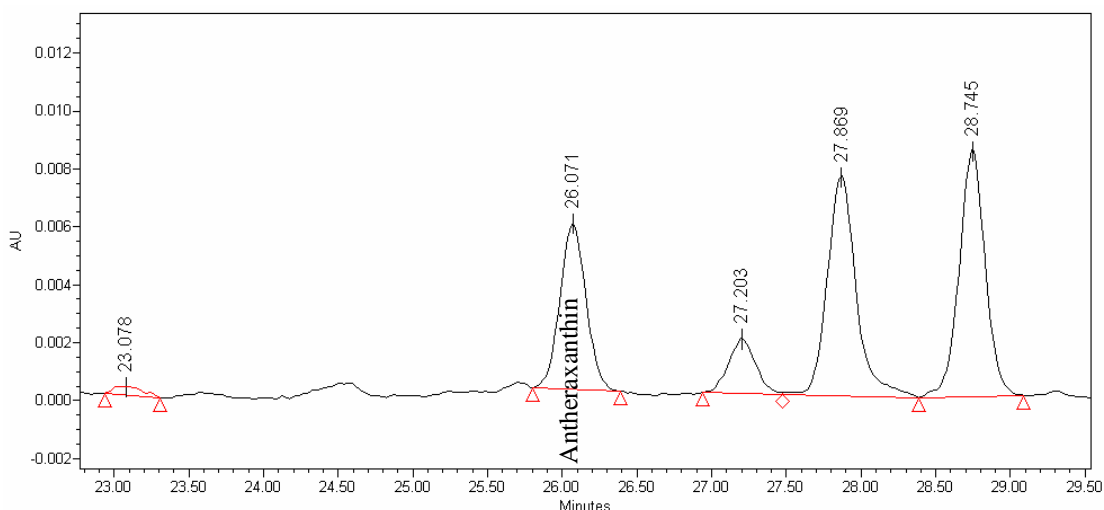
Based on results of the spectrophotometric broad screen, the top 10% of genotypes in total carotenoid content were analyzed via HPLC. Standards included in the carotenoid analysis were violaxanthin, neoxanthin, antheraxanthin, lutein, zeaxanthin, canthaxanthin,  $\beta$ -cryptoxanthin, and  $\beta$ -carotene. A HPLC chromatogram of seven compounds analyzed is shown in Figure 3-12.  $\beta$ -carotene eluted much later than these seven compounds, and separation was not a problem.



**FIGURE 3-12.**  
Chromatogram showing the separation of carotenoid components via HPLC.



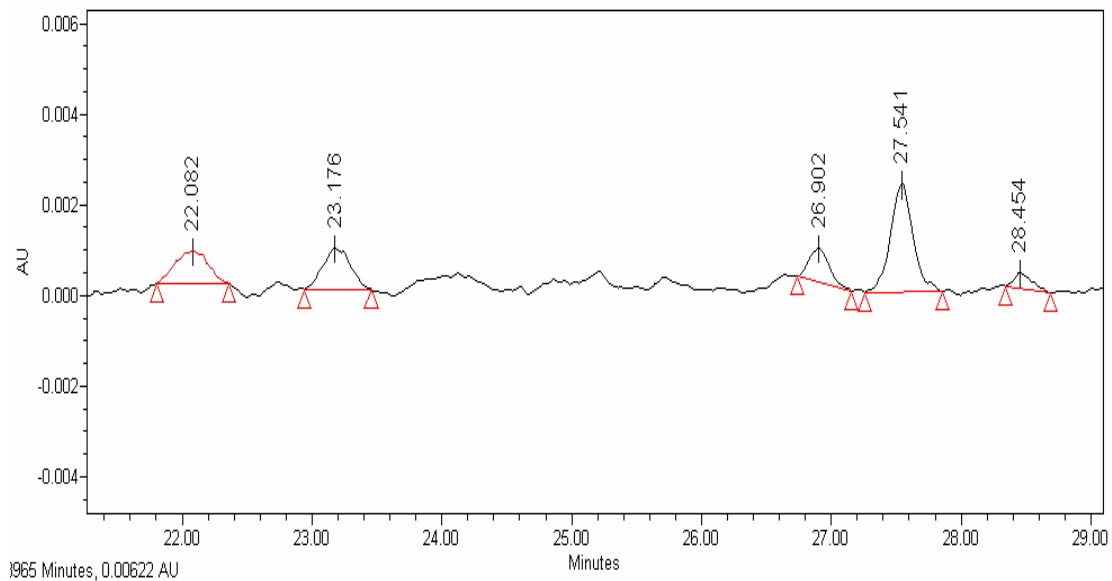
*Field Day Trial 2000* – Genotypes included in the Field Day Trial 2000 analysis included the top 10% of genotypes from the carotenoid broad screen, as well as Russet Norkotah and its intracloonal variants, and 3 yellow flesh Texas advanced selections. Five other varieties were run for comparison with the 2001 data. Genotypes in the top 10% included ATX82539-4Ru, Chipeta, TX1674-1W/Y, CORN8, NDTX4784-7R, NDTX5067-2R, BTX1810-3a, Dark Red Norland, Purple Peruvian, and CORN3. To determine the range of carotenoids found in the varieties analyzed, two varieties which were very low in total carotenoid content, Atlantic and A91790-13, were analyzed via HPLC. Other genotypes analyzed were TXNS296, TXNS112, TXNS102, TXNS278, TXNS223, CORN3, Russet Norkotah, TX1523-1Ru/Y, Russet Burbank, BTX1544-2W/Y, TX1673-2W/Y, Vivaldi, All Blue, and Morning Gold. Although many peaks were observed, particularly in yellow-flesh samples, only antheraxanthin matched retention time and spectra with compounds in the library. TX1674-1W/Y and ATX82539-4Ru each contained antheraxanthin, with concentrations of 14.45 and 18.75  $\mu\text{g}/100\text{gfw}$ , respectively (Figure 3-13). In addition to peak matches for antheraxanthin, there were frequent retention time matches for lutein, violaxanthin, canthaxanthin, neoxanthin, and zeaxanthin; however, the spectra were slightly different than the spectra of standard compounds.



**FIGURE 3-13.**  
**Carotenoid chromatogram for ATX82539-4Ru.**

*Field Day Trial 2001* – Entries in the 2001 Field Day Trial included in the HPLC analysis were TX1674-1W/Y, Yukon Gold, BTX1544-2W/Y, BTX1749-2Ru/Y, BTX1754-1W/Y, A9202-1Ru, Latona, ATX96007-1Pu/Y, CORN8, ATX91137-1Ru, NDTX4304-1R, ATX92230-1Ru, TXNS296, TXNS112, TXNS249, TXNS102, TXNS278, TXNS223, CORN3, Russet Norkotah, TX1523-1Ru/Y, Russet Burbank, NDTX4271-5R, Vivaldi, Sating, Platina, Morning Gold, and Dark Red Norland. These genotypes included the top10% from the broad screen, the 2 genotypes which were lowest in carotenoid content from the broad screen, Russet Norkotah and its intraclonal variants, and well known and yellow flesh varieties. While more carotenoids were identified in the analysis of this trial than that of the 2000 Field Day Trial, results were still very low. Neoxanthin and lutein were the only compounds identified in genotypes

from Field Day Trial 2001. Sating contained 4.65  $\mu\text{g}$  neoxanthin/100gfw, and Platina and Morning Gold contained 8.25 and 8.9  $\mu\text{g}$  lutein/100gfw. As in the Field Day 2000 trial, other peaks were observed, but none of them matched both the retention time and spectra of the standards. Many peaks matched the retention times, however. Figure 3-14 shows BTX1749-2Ru/Y. While there were no matches to the spectral library, there were retention time matches for violaxanthin, neoxanthin, antheraxanthin, lutein, and zeaxanthin.



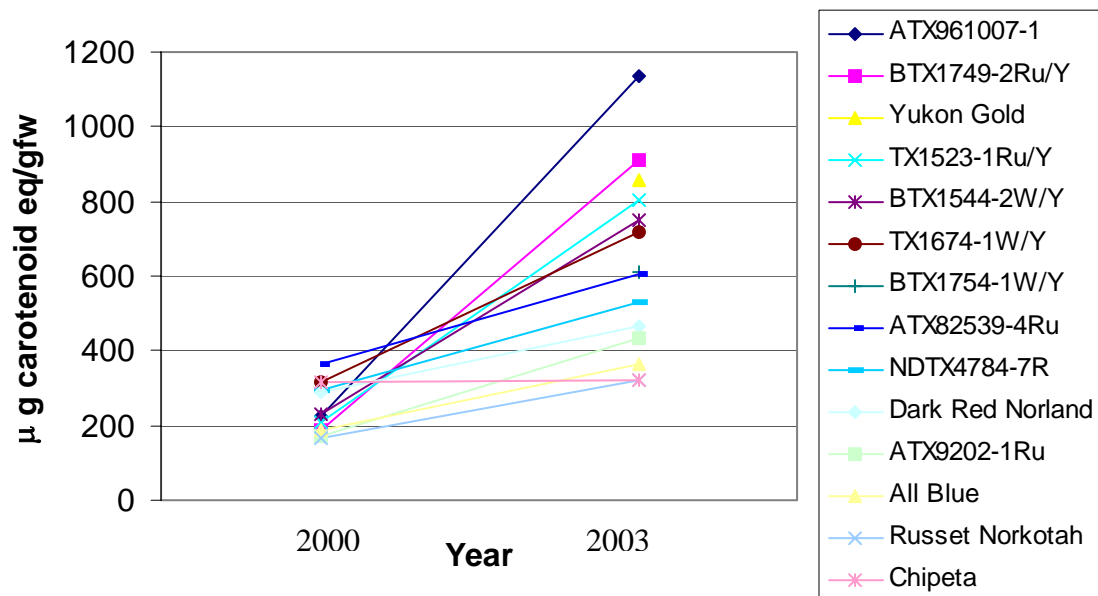
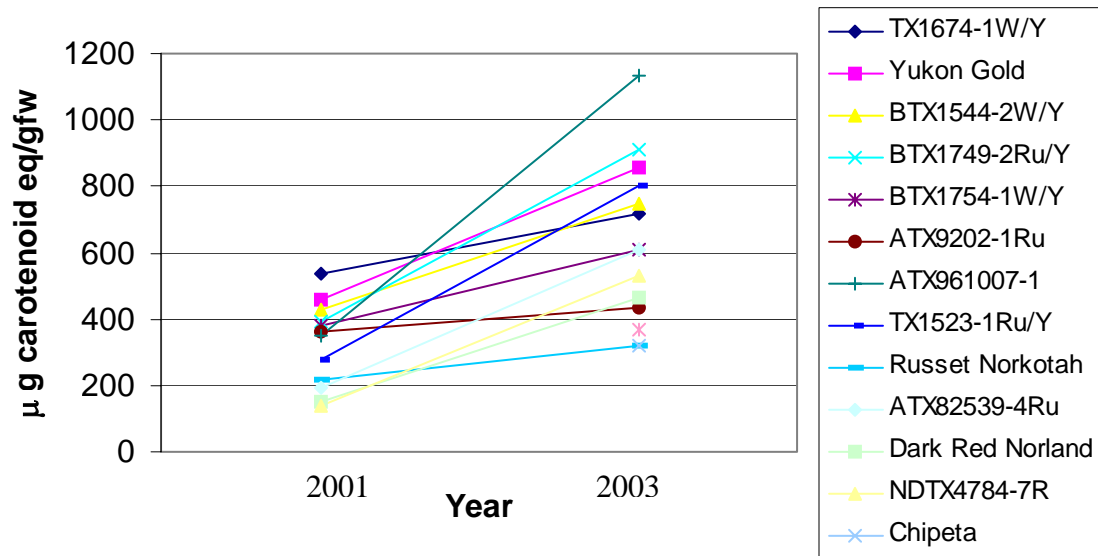
**FIGURE 3-14.**  
Carotenoid HPLC chromatogram for BTX1749-2Ru/Y grown in Field Day Trial 2001.

*Check Genotypes for Field Day 2000 and Field Day 2001* – Since the carotenoid content observed in the Field Day Trials 2000 and 2001 were so far below the previously

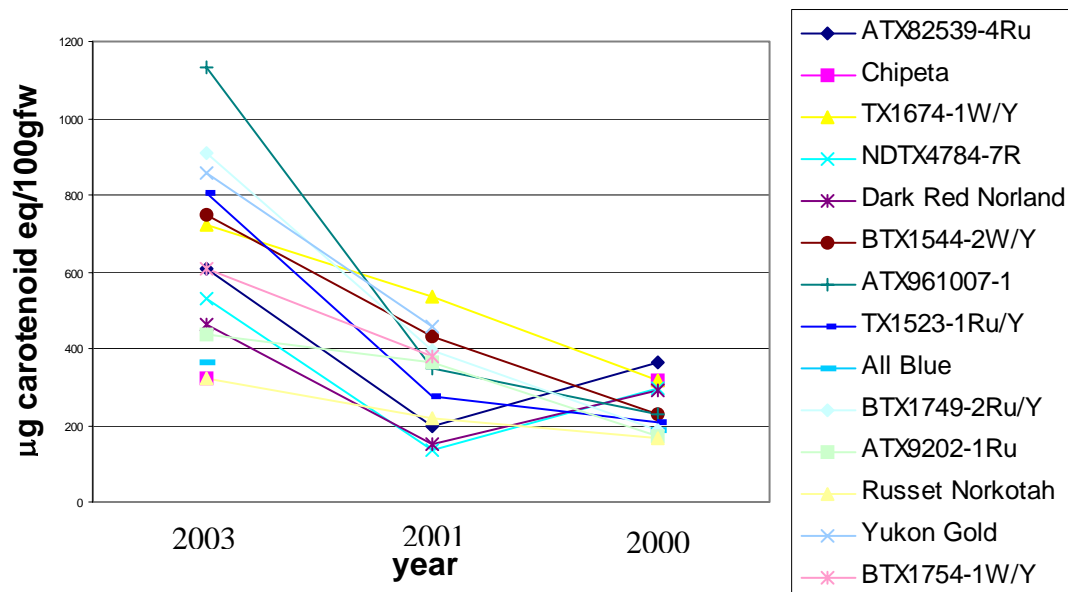
reported amounts, several of these samples were re-examined from Field Day Trial 2003. It was suspected that due to the large number of genotypes analyzed and the time in storage, many of the carotenoids in the samples and sample extracts were degraded, or had changed into different compounds. Fourteen genotypes were re-examined by processing, performing extractions, and running spectrophotometric and HPLC analyses in a single week. Suspicions of degradation during storage were confirmed with both spectrophotometric and HPLC analysis. Comparison of the samples from the three field day trials revealed an average of 164% loss of carotenoids between Field Day Trial 2000 and Field Day Trial 2003, and a 132% loss between 2001 and 2003 (Table 3-16). More loss in carotenoid content was attributed to the ethanol fraction than was attributed to the hexane fraction. When the genotypes were ranked in order of carotenoid content, the order was quite consistent between 2001 and 2003, but not as consistent between 2000 and 2003 (Figure 3-15). When the samples are ranked in relative order of carotenoid content across all three years, all of the top varieties, with the exception of ATX82539-4Ru, are yellow-fleshed. It's interesting to note that the variance decreases with increasing age of samples. The Field Day Trial 2003 samples had a variance of 59439, while the Field Day 2001 samples had a variance of 16385. This is a 3.6 fold loss in variance in carotenoid content. Even more drastic is the comparison of the Field Day Trial 2003 and the Field Day Trial 2000 samples. The Field Day Trial 2000 samples showed a variance of 4439, which is a 13 fold decrease in variance from the 2003 samples. This loss in variance is demonstrated in Figure 3-16.

TABLE 3-16 – *Comparison of Field Day Trial 2003 samples with Field Day Trial 2000 and 2001.*

<b>Genotype</b>	<b>µg carotenoid eq/100gfw</b>		
	<b>Total 2003</b>	<b>Total 2001</b>	<b>Total 2000</b>
BTX1544-2W/Y	749	430	230
Yukon Gold	855	457	NA
BTX1749-2Ru/Y	910	392	186
Chipeta	320	NA	317
ATX82539-4Ru	607	195	366
BTX1754-1W/Y	610	381	NA
Dark Red Norland	465	149	288
ATX9202-1Ru	435	363	173
TX1523-1Ru/Y	804	277	208
TX1674-1W/Y	720	536	306
NDTX4784-7R	532	136	295
Russet Norkotah	321	216	167
ATX961007-1	1134	347	226
All Blue	366	NA	189
<b>average</b>	<b>630</b>	<b>323</b>	<b>247</b>



**FIGURE 3-15.**  
 The relative order of the genotypes is quite consistent between 2001 and 2003, but less consistent between 2000 and 2003.



**FIGURE 3-16.**  
Total carotenoid content of tubers grown in Field Day Trial 2000, 2001, and 2003.

HPLC analysis revealed very similar results to the spectrophotometric analysis; however, the results were much more dramatic. Lutein, violaxanthin, antheraxanthin, and neoxanthin were identified in the samples analyzed from Field Day Trial 2003 (Table 3-17). As in the previously analyzed Field Day Trials, there were peaks which remained unidentified. These peaks had identical retention times to carotenoid compounds of interest; however, they failed to match the standards contained in the spectral library.

TABLE 3-17 – HPLC results of Field Day Trial 2003 Samples (processed, extracted, and analyzed in a single week).

Genotype	μg/100gfw			
	Lutein	Violaxanthin	Antheraxanthin	Neoxanthin
Dark Red Norland	18.55			
ATX961007	35.55	18.25		
TX1674-1W/Y		11.95		
BTX1754-1W/Y	31.15	39.55	18.40	13.25
BTX1544-2W/Y		29.90		13.10
ATX82539-4Ru	48.75	15.10		

It has been previously reported that during storage, the amount of carotenoid esters remains stable in comparison to the amount of free carotenoids (Tevini *et al.* 1986). In addition, Haynes *et al.* (1996) reported a significant effect of environment on yellow-flesh intensity. Keeping previous studies in mind, there are a number of possible explanations for the differing carotenoid contents observed between years. The first, and most obvious explanation is that the carotenoids degraded during storage. The presence of unidentified peaks with similar retention times to the standards suggests that minor modifications could have occurred to the compounds during processing and/or storage. This is further supported by the fact that the spectra, while not identical, are very similar to the standard spectra, thus indicating that at least part of the compound structure is maintained. One possible explanation is that the carotenoids were esterified, causing a slight change in spectra, yet allowing the extracts to maintain their color. Another possibility is that the esters remained in the tuber extracts, while the free carotenoids degraded.



Pendlington *et al.* (1965) reported that during the rapid growth period of potato, carotenoid epoxides are more abundant than free carotenoids. Since the tubers analyzed were harvested at Field Day, they were somewhat immature and still bulking rapidly. It is possible that the unidentified peaks in the samples are carotenoid epoxides as opposed to free carotenoids. While this can explain the presence of unidentified peaks, which were present in all three Field Day Trials, it does not explain the difference between the 2003 results and those from 2000 and 2001.

Environment has a significant impact on carotenoid content. The differences between seasons could be explained by differences in growing conditions between years; however, it is suspicious that the total carotenoid content decreased with increasing storage time.

Finally, it is important to note that many of the other HPLC analyses performed on potato matched peaks based solely on retention time. Had the HPLC peaks in the current study been match based on retention time alone, the levels of individual carotenoids quantified would have been much greater. Slight modifications to structure can have little effect on retention time, and as mentioned earlier, there were many times that peaks matched retention times with known standards, but did not match the spectra. If they did not meet both of these criteria, they were not quantified.

Since all of the samples in a given year were harvested the same day, and it was possible that the living tubers could go through physiological changes while analyzing them one genotype at a time, the decision was made to dice and weigh the tubers immediately after harvest. Due to the number of samples analyzed, the choice to analyze

the phenolic compounds first, and the need to perform both broad and fine screens for antioxidant compounds, it was impossible to analyze all samples quickly. As a result, storage may have been excessive, particularly for the Field Day 2000 samples.

Since the phenolic compounds were analyzed first, and the results obtained from this data are consistent with those obtained from other groups, it is believed that this method of processing, analyzing for antioxidant activity, and performing subsequent HPLC analysis is an efficient and reliable way to screen for phenolic compounds in potato.

On the other hand, given the instability of carotenoids, and the long extraction process, this method could be improved upon. Based on the results of this study, it is recommended that fewer samples be analyzed at one time. Alternatively, broad screens could be conducted on relatively large samples of carotenoids, and subsequent fine screens could be performed using fresh extracts. Furthermore, the broad, spectrophotometric screen could be performed on only the ethanol extract since the hexane extract contributes little to the overall result. Eliminating the hexane extraction would greatly speed up the process and allow the screening to proceed at a much faster pace. Genotypes that perform well on the broad screen could be re-extracted with both hexane and ethanol for the HPLC analysis. It is recommended that, if only one harvest is available, whole tubers for HPLC analysis be stored until the broad screen is complete. HPLC analysis can then be performed on freshly processed tubers, thus eliminating any degradation of carotenoids that might occur in solution. Batch processing for the broad screen does not appear to be a problem as evidenced by the relative consistency between

the 2001 and 2003 samples. Tubers which ranked high in 2001, despite being stored, ranked in the same relative order in 2003.

The objective of this study was to identify parents for use in the Texas Potato Variety Development program, and to identify genotypes already in the program which could be released as new varieties and marketed based on their antioxidant content. Two different sets of parents have been identified based on their carotenoid and phenolic contents. The genotypes, which appear to be consistently high in carotenoid content are TX1674-1W/Y, BTX1544-2W/Y, CORN8, BTX1749-2Ru/Y, ATX9202-1Ru, ATX91137-1Ru, TXNS296, Vivaldi, and CORN3. Another advanced selection, which appears to be superior to other genotypes is BTX1754-1W/Y. This genotype is of interest because it contains a wide array of carotenoid compounds including lutein, violaxanthin, antheraxanthin, and neoxanthin. A white flesh variety of interest is ATX961007-1 P/Y. While containing white flesh, this variety ranked high in Field Day Trial 2001, as well as when analyzed with the 2003 check varieties. Furthermore, during HPLC analysis, it was shown to contain significant amounts of lutein and violaxanthin.

Genotypes considered to be high in antioxidant activity and phenolics which are of interest to the variety development program are as follows: Russet Norkotah, ATX91137-1Ru, ATX9202-1Ru, CORN8, Ranger Russet, ATX92230-1Ru, Stampede Russet, BTX1810-1, TXNS296, and COTX93053-4R. In addition, the purple-flesh varieties All Blue and Purple Peruvian, as well as the purple skinned yellow-fleshed advanced selection ATX961007-1P/Y are of interest because of their high levels of anthocyanins.

## CHAPTER IV

### INTERSPECIFIC VARIABILITY FOR ANTIOXIDANT ACTIVITY AMONG *SOLANUM* SPECIES

#### Introduction

A number of studies have investigated the level of compounds with antioxidant activity contained in cultivated potato (*S. tuberosum* L.); however, little is known about the levels of these important compounds in wild tuber-bearing species. Since antioxidants serve as plant defense compounds, it is likely that, due to natural selection, wild species contain higher levels of these compounds than do cultivated varieties. If levels of these compounds are significantly higher than those of cultivated potato, it could be beneficial to incorporate them into a breeding program, with the goal of introgressing these wild genes into the gene pool of cultivated potato. Wild germplasm could serve as a source of important health benefiting compounds in this fourth most important food crop.

Phenolic content in the flesh of eight wild tuber-bearing species was found to range from 84-274  $\mu\text{g}$ , while that in the flesh of cultivated potato was 157  $\mu\text{g/gfw}$  (Lewis, *et al.* 1988b). A more diverse phenolic profile was observed in the flesh of wild species, which contained protocatechuic acid, chlorogenic acid, and p-coumaric acid. Flavanoids, however, were significantly higher in *S. tuberosum* than in the wild species. Furthermore, it is well documented that tubers produced from diploid yellow-flesh clones are 3-13 fold higher in carotenoid content than tubers of Yukon Gold, suggesting that

wild germplasm may be a good source for carotenoid genes in potato (Lu *et al.* 2001). Brown *et al.* (1993c) also reported high levels of carotenoids in diploid breeding populations. Perhaps the most compelling evidence for using wild species to increase antioxidant content in potato is the fact that the source of yellow flesh in many popular varieties is from the diploid potato species *S. phureja* (Johnston and Rowberry 1981; Coffin *et al.* 1988a; and Coffin *et al.* 1988b).

Since intensive selection in wild tuber-bearing species has not been practiced by breeders, it is expected that the genetic base for many traits, including antioxidant activity, is broader than that of cultivated varieties.

The objective of this investigation was to conduct a broad screen of wild tuber bearing species to determine if there are accessions which are significantly higher in antioxidant activity and carotenoid content than found in cultivated potato. If the level of these important compounds is higher in the accessions, parents from these wild species can be selected for use in a breeding program, with the ultimate goal of producing varieties that are higher in antioxidant compounds than those currently available.

## **Materials and Methods**

### ***Plant Materials***

Thirty accessions representing 27 wild species were obtained from Dr. John Bamberg, Project leader at the Inter-Regional Potato Introduction Station (Sturgeon Bay, WI) in September and October of 2000 (Table 4-1). In addition, 65 accessions, representing 25 species, and 2 field replications were obtained in January 2001 (Table 4-2). Individual accessions were mixed populations, representing one or two tuber families, and were used as a broad screen for antioxidant and carotenoid contents. These groups will be referred to as Bamberg 1 and Bamberg 2, respectively. In addition to these accessions, 50 *S. jamesii* accessions, obtained in November 2001, were analyzed for antioxidant activity and phenolic content (Table 4-4). Based on results from these three groups and the ability to cross with tetraploid *S. tuberosum*, accessions and species were selected to fine-screen potato germplasm for antioxidant compounds. The final group of tubers was received in April 2002 (Bamberg 02), and was comprised of 272 entries of single genotypes (as opposed to mixed populations), representing 23 species (Table 4-3). A broad range of cultivated genotypes were analyzed simultaneously to determine the differences between wild and cultivated genotypes (Chapter III).

TABLE 4-1 – *Mixed populations obtained from the Inter-Regional Potato Introduction Station, Sturgeon Bay, WI (Bamberg 1).*

<b>Accession</b>	<b>Species</b>	<b>Accession</b>	<b>Species</b>
PI 184764	<i>pinnatisectum</i>	PI 558404	<i>hougasii</i>
PI 255545	<i>polytrichon</i>	PI 558464	<i>demissum</i>
PI 283088	<i>laxissimum</i>	PI 564029	<i>fenderli</i>
PI 310993	<i>lignicaule</i>	PI 564050	<i>jamesii</i>
PI 320266	<i>commersonii</i>	PI 568929	<i>bukasovii</i>
PI 320316	<i>microdontum</i>	PI 595507	<i>berthaultii</i>
PI 320342	<i>polyadenium</i>	PI 597710	<i>oplocense</i>
PI 458374	<i>vernei</i>	PI 597721	<i>hoopesii</i>
PI 473086	<i>gourlayi</i>	PI 597732	<i>megistacrolobum</i>
PI 47310A	<i>median</i>	PI 597753	<i>hoopesii</i>
PI 473412	<i>commersonii</i>	PI 597768	<i>sparsipilum</i>
PI 498314	<i>violaceimarmoratum</i>	PI 604040	<i>alandiae</i>
PI 545828	<i>nayaritense</i>	PI 607860	<i>oxycarpum</i>
PI 545832	<i>brachistotrichum</i>	PI 607866	<i>brachycarpum</i>
PI 558101	<i>oplocense</i>	PNT bulked	<i>pinnatisectum</i>

TABLE 4-2 - *Mixed populations obtained from the Inter-Regional Potato Introduction Station, Sturgeon Bay, WI in January 2001 (Bamberg 2).*

Accession	Species	Accession	Species
PI 160208	<i>demissum</i>	PI 472661	<i>acaule</i>
PI 161173	<i>verrucosum</i>	PI 472842	<i>commersonii</i>
PI 184770	<i>polytrichon</i>	PI 472894	<i>infundibuliforme</i>
PI 184774	<i>pinnantisectum</i>	PI 472923	<i>Kurtzianum</i>
PI 195190	<i>jamesii</i>	PI 472941	<i>kurtzianum</i>
PI 195204	<i>stenotomum</i>	PI 472986	<i>spgazzinii</i>
PI 195206	<i>tarijense</i>	PI 473062	<i>gourlayi</i>
PI 197760	<i>chacoense</i>	PI 473133	<i>megistacrolobum</i>
PI 205407	<i>spgazzinii</i>	PI 473171	<i>microdontum</i>
PI 205510	<i>stoloniferum</i>	PI 473185	<i>oplocense</i>
PI 218225	<i>microdontum</i>	PI 473190	<i>oplocense</i>
PI 230589	<i>demissum</i>	PI 473243	<i>tarijense</i>
PI 243503	<i>commersonii</i>	PI 473336	<i>tarijense</i>
PI 243513	<i>bulbocastanum</i>	PI 473345	<i>canasense</i>
PI 249929	<i>papita</i>	PI 473411	<i>commersonii</i>
PI 255547	<i>polytrichon</i>	PI 473481	<i>acaule</i>
PI 265579	<i>gourlayi</i>	PI 497998	<i>fendleri</i>
PI 265863	<i>canasense</i>	PI 498004	<i>fendleri</i>
PI 265867	<i>infundibuliforme</i>	PI 498033	<i>papita</i>
PI 265873	<i>megistacrolobum</i>	PI 498039	<i>polytrichon</i>
PI 275139	<i>chacoense</i>	PI 498057	<i>stoloniferum</i>
PI 275156	<i>fendleri</i>	PI 498232	<i>demissum</i>
PI 275187	<i>bulbocastanum</i>	PI 498351	<i>infundibuliforme</i>
PI 275236	<i>pinnantisectum</i>	PI 498359	<i>kurtzianum</i>
PI 275262	<i>jamesii</i>	PI 498383	<i>megistacrolobum</i>
PI 283109	<i>stoloniferum</i>	PI 500041	<i>microdontum</i>
PI 310956	<i>canasense</i>	PI 500047	<i>acaule</i>
PI 320293	<i>chacosense</i>	PI 500049	<i>gourlayi</i>
PI 320316	<i>microdontum</i>	PI 500053	<i>spgazzinii</i>
PI 347766	<i>pinnantisectum</i>	PI 545725	<i>papita</i>
PI 347773	<i>tuberosum</i>	PI 545751	<i>bulbocastanum</i>
PI 435079	<i>oplocense</i>	PI 597710	<i>oplocense</i>
PI 458425	<i>jamesii</i>		



TABLE 4-3 - *Accessions obtained from the Inter-Regional Potato Introduction Station, Sturgeon Bay, WI in April 2002 (Bamberg 02).*

Accession	ID	Species	Accession	ID	Species
PI 197760	AO 10.3	<i>chacoense</i>	PI 218225	AO 34.14	<i>microdontum</i>
PI 197760	AO 10.4	<i>chacoense</i>	PI 218225	AO 34.15	<i>microdontum</i>
PI 197760	AO 10.5	<i>chacoense</i>	PI 218225	AO 34.16	<i>microdontum</i>
PI 197760	AO 10.6	<i>chacoense</i>	PI 218225	AO 34.17	<i>microdontum</i>
PI 197760	AO 10.7	<i>chacoense</i>	PI 218225	AO 34.18	<i>microdontum</i>
PI 197760	AO 10.8	<i>chacoense</i>	PI 498383	AO 39.1	<i>megistacrolobum</i>
PI 197760	AO 10.9	<i>chacoense</i>	PI 498383	AO 39.2	<i>megistacrolobum</i>
PI 197760	AO 10.10	<i>chacoense</i>	PI 498383	AO 39.3	<i>megistacrolobum</i>
PI 197760	AO 10.11	<i>chacoense</i>	PI 498383	AO 39.4	<i>megistacrolobum</i>
PI 197760	AO 10.12	<i>chacoense</i>	PI 498383	AO 39.5	<i>megistacrolobum</i>
PI 197760	AO 10.13	<i>chacoense</i>	PI 498383	AO 39.6	<i>megistacrolobum</i>
PI 197760	AO 10.14	<i>chacoense</i>	PI 498383	AO 39.7	<i>megistacrolobum</i>
PI 197760	AO 10.15	<i>chacoense</i>	PI 498383	AO 39.8	<i>megistacrolobum</i>
PI 197760	AO 10.16	<i>chacoense</i>	PI 498383	AO 39.9	<i>megistacrolobum</i>
PI 197760	AO 10.17	<i>chacoense</i>	PI 498383	AO 39.10	<i>megistacrolobum</i>
PI 275262	AO 28.1	<i>jamesii</i>	PI 498383	AO 39.11	<i>megistacrolobum</i>
PI 275262	AO 28.2	<i>jamesii</i>	PI 498383	AO 39.12	<i>megistacrolobum</i>
PI 275262	AO 28.3	<i>jamesii</i>	PI 498383	AO 39.13	<i>megistacrolobum</i>
PI 275262	AO 28.4	<i>jamesii</i>	PI 498383	AO 39.14	<i>megistacrolobum</i>
PI 275262	AO 28.5	<i>jamesii</i>	PI 498383	AO 39.15	<i>megistacrolobum</i>
PI 275262	AO 28.6	<i>jamesii</i>	PI 498383	AO 39.16	<i>megistacrolobum</i>
PI 275262	AO 28.7	<i>jamesii</i>	PI 498383	AO 39.17	<i>megistacrolobum</i>
PI 275262	AO 28.8	<i>jamesii</i>	PI 498383	AO 39.18	<i>megistacrolobum</i>
PI 275262	AO 28.9	<i>jamesii</i>	PI 500053	AO 60.2	<i>spgazzinii</i>
PI 275262	AO 28.10	<i>jamesii</i>	PI 500053	AO 60.3	<i>spgazzinii</i>
PI 275262	AO 28.11	<i>jamesii</i>	PI 500053	AO 60.4	<i>spgazzinii</i>
PI 275262	AO 28.12	<i>jamesii</i>	PI 500053	AO 60.5	<i>spgazzinii</i>
PI 275262	AO 28.13	<i>jamesii</i>	PI 500053	AO 60.6	<i>spgazzinii</i>
PI 275262	AO 28.14	<i>jamesii</i>	PI 500053	AO 60.7	<i>spgazzinii</i>
PI 275262	AO 28.15	<i>jamesii</i>	PI 500053	AO 60.8	<i>spgazzinii</i>
PI 275262	AO 28.16	<i>jamesii</i>	PI 500053	AO 60.9	<i>spgazzinii</i>
PI 218225	AO 34.2	<i>microdontum</i>	PI 500053	AO 60.10	<i>spgazzinii</i>
PI 218225	AO 34.3	<i>microdontum</i>	PI 500053	AO 60.11	<i>spgazzinii</i>
PI 218225	AO 34.4	<i>microdontum</i>	PI 500053	AO 60.12	<i>spgazzinii</i>
PI 218225	AO 34.5	<i>microdontum</i>	PI 500053	AO 60.13	<i>spgazzinii</i>
PI 218225	AO 34.6	<i>microdontum</i>	PI 500053	AO 60.14	<i>spgazzinii</i>
PI 218225	AO 34.7	<i>microdontum</i>	PI 500053	AO 60.15	<i>spgazzinii</i>
PI 218225	AO 34.8	<i>microdontum</i>	PI 500053	AO 60.16	<i>spgazzinii</i>
PI 218225	AO 34.9	<i>microdontum</i>	PI 500053	AO 60.17	<i>spgazzinii</i>

TABLE 4-3 - *continued*

Accession	ID	Species	Accession	ID	Species
PI 218225	AO 34.10	<i>microdontum</i>	PI 500053	AO 60.18	<i>spgazzinii</i>
PI 218225	AO 34.12	<i>microdontum</i>	PI 472846	EV 691	<i>commersonii</i>
PI 218225	AO 34.13	<i>microdontum</i>	PI 590921	EV 695	<i>Commersonii</i>
PI 320295	EV 772	<i>infundibuliforme</i>	PI 558379	TAX 13	<i>bulbocastanum</i>
PI 414147	EV 774	<i>infundibuliforme</i>	PI 190115	TAX 30	<i>pinnatisectum</i>
PI 435076	EV 776	<i>infundibuliforme</i>	PI 275231	TAX 31	<i>pinnatisectum</i>
PI 442676	EV 778	<i>infundibuliforme</i>	PI 275232	TAX 32	<i>pinnatisectum</i>
PI 458322	EV 782	<i>infundibuliforme</i>	PI 275236	TAX 33	<i>pinnatisectum</i>
PI 458325	EV 785	<i>infundibuliforme</i>	PI 251720	TAX 40	<i>brachistotrichum</i>
PI 472856	EV 787	<i>infundibuliforme</i>	PI 255527	TAX 41	<i>brachistotrichum</i>
PI 472860	EV 791	<i>infundibuliforme</i>	PI 255528	TAX 42	<i>brachistotrichum</i>
PI 472862	EV 793	<i>infundibuliforme</i>	PI 255529	TAX 43	<i>brachistotrichum</i>
PI 472869	EV 800	<i>infundibuliforme</i>	PI 255530	TAX 44	<i>brachistotrichum</i>
PI 472871	EV 802	<i>infundibuliforme</i>	PI 320265	TAX 45	<i>brachistotrichum</i>
PI 472873	EV 804	<i>infundibuliforme</i>	PI 497993	TAX 46	<i>brachistotrichum</i>
PI 472876	EV 806	<i>infundibuliforme</i>	PI 498217	TAX 48	<i>brachistotrichum</i>
PI 472878	EV 808	<i>infundibuliforme</i>	PI 545812	TAX 49	<i>brachistotrichum</i>
PI 472880	EV 810	<i>infundibuliforme</i>	PI 545813	TAX 50	<i>brachistotrichum</i>
PI 472882	EV 812	<i>infundibuliforme</i>	PI 545814	TAX 51	<i>brachistotrichum</i>
PI 472884	EV 814	<i>infundibuliforme</i>	PI 545815	TAX 52	<i>brachistotrichum</i>
PI 472886	EV 816	<i>infundibuliforme</i>	PI 545817	TAX 53	<i>brachistotrichum</i>
PI 472888	EV 818	<i>infundibuliforme</i>	PI 545832	TAX 54	<i>brachistotrichum</i>
PI 472892	EV 820	<i>infundibuliforme</i>	PI 558401	TAX 55	<i>brachistotrichum</i>
PI 472894	EV 822	<i>infundibuliforme</i>	PI 558460	TAX 56	<i>brachistotrichum</i>
PI 472896	EV 824	<i>infundibuliforme</i>	PI 558460	TAX 56B	<i>brachistotrichum</i>
PI 472898	EV 826	<i>infundibuliforme</i>	PI 184762	TAX 57	<i>cardiophyllum</i>
PI 472901	EV 828	<i>infundibuliforme</i>	PI 184771	TAX 58	<i>cardiophyllum</i>
PI 472903	EV 830	<i>infundibuliforme</i>	PI 186548	TAX 59	<i>cardiophyllum</i>
PI 472907	EV 834	<i>infundibuliforme</i>	PI 255519	TAX 60	<i>cardiophyllum</i>
PI 472909	EV 836	<i>infundibuliforme</i>	PI 255520	TAX 61	<i>cardiophyllum</i>
PI 472913	EV 838	<i>infundibuliforme</i>	PI 275212	TAX 62	<i>cardiophyllum</i>
PI 472915	EV 840	<i>infundibuliforme</i>	PI 275213	TAX 63	<i>cardiophyllum</i>
PI 472917	EV 842	<i>infundibuliforme</i>	PI 275214	TAX 64	<i>cardiophyllum</i>
PI 473414	EV 844	<i>infundibuliforme</i>	PI 275216	TAX 66	<i>cardiophyllum</i>
PI 473522	EV 846	<i>infundibuliforme</i>	PI 283062	TAX 68	<i>cardiophyllum</i>
PI 498333	EV 850	<i>infundibuliforme</i>	PI 283063	TAX 69	<i>cardiophyllum</i>
PI 498335	EV 852	<i>infundibuliforme</i>	PI 341231	TAX 70	<i>cardiophyllum</i>
PI 498337	EV 854	<i>infundibuliforme</i>	PI 341233	TAX 71	<i>cardiophyllum</i>
PI 498339	EV 856	<i>infundibuliforme</i>	PI 341235	TAX 72	<i>cardiophyllum</i>
PI 498341	EV 858	<i>infundibuliforme</i>	PI 347759	TAX 73	<i>cardiophyllum</i>
PI 498343	EV 860	<i>infundibuliforme</i>	PI 545753	TAX 74	<i>cardiophyllum</i>
PI 498345	EV 862	<i>infundibuliforme</i>	PI 545824	TAX 76	<i>cardiophyllum</i>
PI 498351	EV 868	<i>infundibuliforme</i>	PI 595467	TAX 78	<i>cardiophyllum</i>

TABLE 4-3 – *continued*

Accession	ID	Species	Accession	ID	Species
PI 498354	EV 870	<i>infundibuliforme</i>	PI 595476	TAX 80	<i>cardiophyllum</i>
PI 500046	EV 873	<i>infundibuliforme</i>	PI 595480	TAX 83	<i>cardiophyllum</i>
PI 545894	EV 875	<i>infundibuliforme</i>	PI 595482	TAX 84	<i>cardiophyllum</i>
PI 566767	EV 881	<i>infundibuliforme</i>	PI 595486	TAX 85	<i>cardiophyllum</i>
PI 566769	EV 883	<i>infundibuliforme</i>	PI 595488	TAX 86	<i>cardiophyllum</i>
PI 275184	TAX 6	<i>bulbocastanum</i>	PI 595489	TAX 87	<i>cardiophyllum</i>
PI 545752	TAX 12	<i>bulbocastanum</i>	PI 597678	TAX 88	<i>Cardiophyllum</i>
PI 605371	TAX 141	<i>jamesii</i>	PI 190115	HERB 3.1-.7	<i>pinnatisectum</i>
PI 612456	TAX 142	<i>jamesii</i>	PI 230489	HERB 4.1-.9	<i>pinnatisectum</i>
PI 545820	TAX 143	<i>nyaritense</i>	PI 253214	HERB 5.1-.8	<i>pinnatisectum</i>
PI 545827	TAX 144	<i>nyaritense</i>	PI 275230	HERB 6.1-.9	<i>pinnatisectum</i>
PI 595478	TAX 145	<i>sambucinum</i>	PI 275231	HERB 7.1-.9	<i>pinnatisectum</i>
PI 604209	TAX 146	<i>sambucinum</i>	PI 275232	HERB 8.1-.8	<i>pinnatisectum</i>
PI 558483	TAX 150	<i>verrucosum</i>	PI 275233	HERB 9.1-.9	<i>pinnatisectum</i>
PI 611104	TAX 198	<i>edinense</i>	PI 275234	HERB 10.1-.3	<i>pinnatisectum</i>
PI 320266	F2 4.2	<i>commersonii</i>	PI 275235	HERB 11.1-.9	<i>pinnatisectum</i>
PI 320266	F2 4.3	<i>commersonii</i>	PI 275236	HERB 12.1-.9	<i>pinnatisectum</i>
PI 320266	F2 4.4	<i>commersonii</i>	PI 347766	HERB 13.1-.9	<i>pinnatisectum</i>
PI 320266	F2 4.5	<i>commersonii</i>	PI 537023	HERB 14.1-.7	<i>pinnatisectum</i>
PI 320266	F2 4.6	<i>commersonii</i>	PI 473481	FFAO 2	<i>acaule</i>
PI 320266	F2 4.7	<i>commersonii</i>	PI 243510	FFAO 4	<i>bulbocastanum</i>
PI 320266	F2 4.8	<i>commersonii</i>	PI 275187	FFAO 5	<i>bulbocastanum</i>
PI 320266	F2 4.9	<i>commersonii</i>	PI 545751	FFAO 6	<i>bulbocastanum</i>
PI 320266	F2 4.10	<i>commersonii</i>	PI 265863	FFAO 7*	<i>canasense</i>
PI 320266	F2 4.11	<i>commersonii</i>	PI 310956	FFAO 8*	<i>canasense</i>
PI 320266	F2 4.12	<i>commersonii</i>	PI 473345	FFAO 9*	<i>canasense</i>
PI 320266	F2 4.13	<i>commersonii</i>	PI 197760	FFAO 10	<i>chacoense</i>
PI 320266	F2 4.14	<i>commersonii</i>	PI 275139	FFAO 11	<i>chacoense</i>
PI 320266	F2 4.15	<i>commersonii</i>	PI 320293	FFAO 12	<i>chacoense</i>
PI 320266	F2 4.17	<i>commersonii</i>	PI 500049	FFAO 24	<i>gourlayi</i>
PI 320266	F2 4.18	<i>commersonii</i>	PI 458425	FFAO 29	<i>jamesii</i>
PI 320266	F2 5.1	<i>commersonii</i>	PI 592422	FFAO 30	<i>jamesii</i>
PI 320266	F2 5.2	<i>commersonii</i>	PI 472923	FFAO 31	<i>kurtzianum</i>
PI 320266	F2 5.4	<i>commersonii</i>	PI 472941	FFAO 32	<i>kurtzianum</i>
PI 320266	F2 5.5	<i>commersonii</i>	PI 218225	FFAO 34	<i>microdontum</i>
PI 320266	F2 5.6	<i>commersonii</i>	PI 473171	FFAO 35	<i>microdontum</i>
PI 320266	F2 5.7	<i>commersonii</i>	PI 500041	FFAO 36	<i>microdontum</i>
PI 320266	F2 5.8	<i>commersonii</i>	PI 265873	FFAO 37	<i>megistacrolobum</i>
PI 320266	F2 5.9	<i>commersonii</i>	PI 473190	FFAO 42	<i>oplocense</i>
PI 320266	F2 5.11	<i>commersonii</i>	PI 498130	FFAO 47	<i>okadae</i>
PI 320266	F2 5.12	<i>commersonii</i>	PI 184770	FFAO 49	<i>polytrichon</i>
PI 320266	F2 6.1	<i>commersonii</i>	PI 255547	FFAO 50	<i>polytrichon</i>
PI 320266	F2 6.2	<i>commersonii</i>	PI 498039	FFAO 51	<i>polytrichon</i>

TABLE 4-3 – *continued*

Accession	ID	Species	Accession	ID	Species
PI 320266	F2 6.11	<i>commersonii</i>	PI 184774	FFAO 52	<i>pinnatisectum</i>
PI 320266	F2 6.16	<i>commersonii</i>	PI 545725	FFAO 57	<i>papita</i>
PI 320266	F2 6.17	<i>commersonii</i>	PI 205407	FFAO 58	<i>spgazzinii</i>
PI 320266	320266.1	<i>commersonii</i>	PI 472986	FFAO 59	<i>spgazzinii</i>
PI 320266	320266.2	<i>commersonii</i>	PI 230512	FFAO 62	<i>stenotomum</i>
PI 320266	320266.5	<i>commersonii</i>	PI 205510	FFAO 64	<i>stoloniferum</i>
PI 320266	320266.7	<i>commersonii</i>	PI 283109	FFAO 65	<i>stoloniferum</i>
PI 320266	320266.16	<i>commersonii</i>	PI 195206	FFAO 67	<i>tarijense</i>
PI 320266	320266.17	<i>commersonii</i>	PI 473243	FFAO 68	<i>Tarijense</i>
PI 184774	HERB1.1-.6	<i>pinnatisectum</i>	PI 473336	FFAO 69	<i>tarijense</i>
PI 186553	HERB 2.1-.9	<i>pinnatisectum</i>			

TABLE 4-4 – *S. jamesii* accessions obtained from the Inter-Regional Potato Introduction Station, Sturgeon Bay, WI in November 2001 (*Jamesii*).

Accession	Accession	Accession	Accession
275169	498407	585118	596519
275172	564048	592398	603055
275262	564049	592399	603056
275263	564051	592411	603057
275264	564053	592414	603058
275265	564054	592417	605358
275266	564055	592418	605359
458423	564056	592419	605361
458424	564057	592422	605365
458425	578236	592423	605366
458426	578237	595778	605367
458427	578238	595782	
458428	585116	595784	

### *Extraction of Antioxidants*

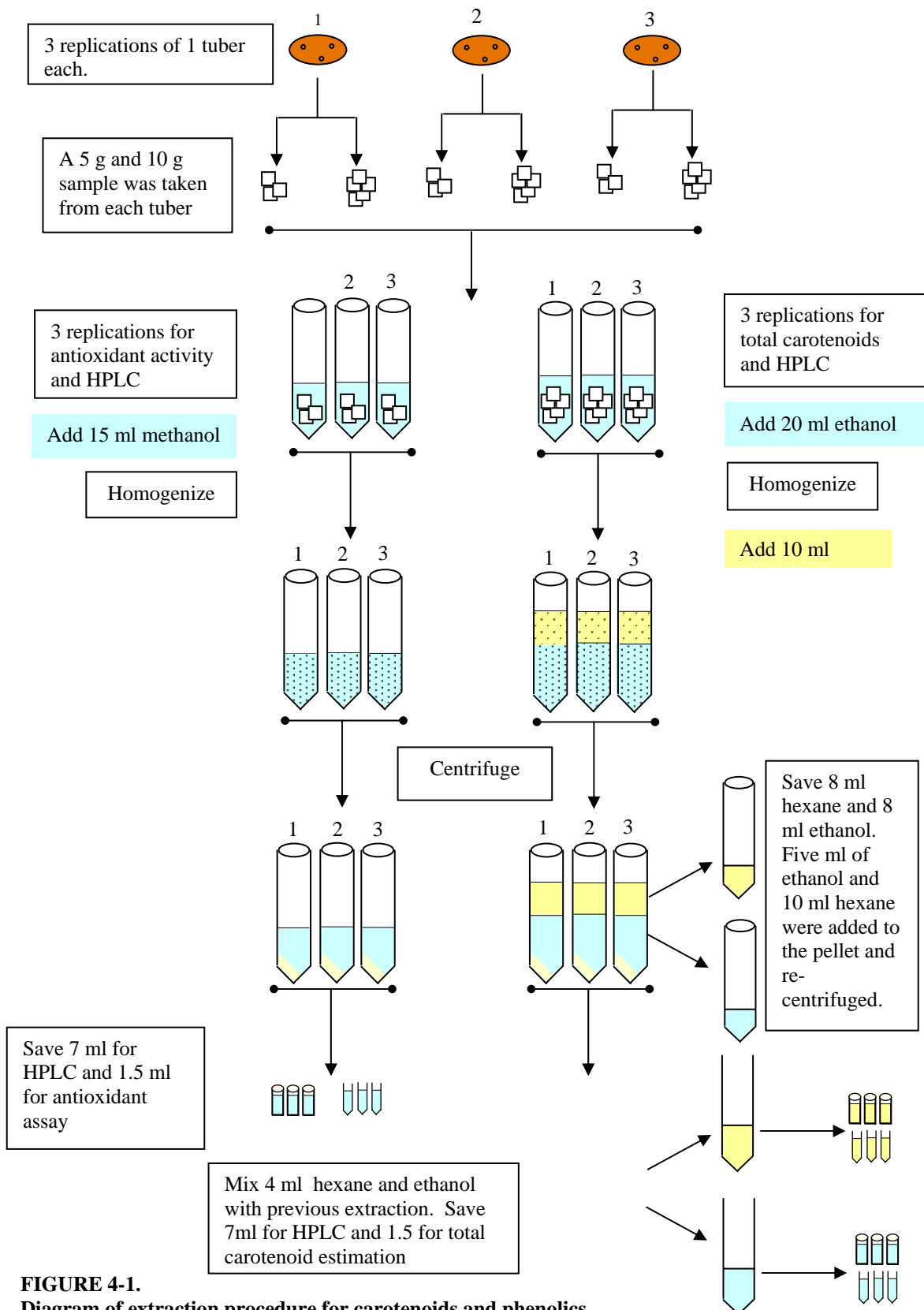
For the evaluation of potato antioxidant activity, total carotenoids, and individual carotenoid and phenolic components via HPLC, whole tubers were diced into quarter inch cubes. Since the wild tubers tend to be small, more than one tuber comprised a single replication. Three groups of tubers per accession were diced and kept separate,

and a representative sample was weighed and stored at  $-20^{\circ}\text{C}$  until extractions were performed. Since tuber material was limited, not all accessions had three replications for each analysis (Figure 4-1).

*Extraction of Phenolics* - For the evaluation of potato antioxidant activity and the HPLC analysis of phenolics, antioxidants were extracted from 5 g tuber samples by mixing 15 ml of methanol and homogenizing with an ultra turrax tissumizer from Tekmar (Cincinnati, Ohio). Homogenized samples were centrifuged at 15,000 rpm for 15 minutes in a refrigerated centrifuge (Beckman model J2-21) using a J-17 rotor. One point five ml of the supernatant were collected in 1.5 ml snap-cap tubes for analysis of total antioxidants, and 7 ml were collected in glass vials for the analysis of individual phenolics via HPLC. The sample extracts were stored at  $-20^{\circ}\text{C}$  until analysis, and the pellet was discarded (Figure 4-1).

*Extraction of Carotenoids* - A 10 g sample of diced tuber tissue was used to extract carotenoids for both the total carotenoid broad screen and the analysis of individual carotenoids via HPLC. Since potatoes contain both oxygenated (i.e.,  $\beta$ -carotene and  $\alpha$ -carotene) and non-oxygenated carotenoids (i.e., lutein and zeaxanthin), both ethanol and hexane were used to ensure complete extraction. Fifteen ml of ethanol

plus BHT (1g/L) were added to 10 g of tuber tissue and homogenized using an ultra turrax tissumizer from Tekmar (Cincinnati, Ohio). Five ml of ethanol +BHT (1g/L) was added to the resulting slurry, and it was incubated overnight at -20C to facilitate a more efficient extraction. The following day, 10 ml of hexane was added, and the sample was centrifuged for 20 minutes at 1600 rpm in a refrigerated centrifuge (Beckman model J2-21) using a J-17 rotor. Eight ml of each layer (hexane and ethanol) were saved in separate falcon tubes, and the remaining solvent was discarded, while the pellet remained at the bottom of the tube. Five ml of methanol and 10 ml of hexane were added to the pellet, and the tube was shaken. The second extract was centrifuged as described above, and 4 ml each of the hexane and ethanol layers were added to the previous extracts. Seven ml of the combined ethanol extracts were saved for HPLC analysis, and 1.5 ml were saved for the estimation of total carotenoids. The hexane extracts were saved in an identical manner (Figure 4-1).



**FIGURE 4-1.**  
**Diagram of extraction procedure for carotenoids and phenolics.**

### ***DPPH Assay for Total Antioxidant Activity***

The determination of antioxidant activity was based on the 2,2-Diphenyl-1-picrylhydrazyl (DPPH) analysis described by Brand-Williams *et al.* (1995). DPPH, a stable radical, absorbs at 515 nm, and upon reduction by an antioxidant species, a decrease in absorbance is observed. The change in color (from purple to yellow) provided an easy and rapid way to evaluate the antiradical activities of potato extracts. Since this study dealt with such a large number of samples, the DPPH assay was used as a broad screen to identify those genotypes that were high in antioxidant activity.

DPPH stock solution was prepared by dissolving 24 mg of DPPH in 100 ml of methanol. The stock was diluted ~10:55 until the display on the spectrophotometer at 515 nm read 1.1. Two thousand eight hundred fifty  $\mu$ l of the dilute DPPH was allowed to react with 150  $\mu$ l of the tuber methanol extract for 15 minutes, and then read on the spectrophotometer at 515 nm. All accessions were analyzed in triplicate when enough tuber material was available.

Two standard curves, one with Ascorbic acid, and one with trolox (6-Hydroxy-2,5,7,8-tetramethylchroman-2-carboxylic acid – a commonly used synthetic antioxidant), were prepared, and absorbance readings were converted to  $\mu$ M equivalents of these compounds. While most studies report antioxidant activity based on DPPH in trolox equivalents, an ascorbic acid curve was also prepared because it is a compound with which the general public is familiar, while trolox is not (Appendix O). Three samples were prepared separately for each concentration, and were assayed in the same manner as the potato samples. One hundred fifty  $\mu$ l of the standard at various concentrations was



allowed to react for 15 minutes with 2850  $\mu\text{l}$  of the DPPH working solution. Curves were prepared based on absorbance at 515 nm.

### ***HPLC Analysis of Phenolic Compounds***

Based on the results of the DPPH analysis, the top 10% of genotypes in antioxidant activity were chosen for analysis in triplicate via HPLC. The reduction in numbers was necessary because of both monetary and time constraints involved in HPLC analysis.

*Concentrating the Samples* – A 7 ml sample of the 5 g methanol extract was retained for analysis of individual phenolic components on the HPLC. The samples were dried to completion in a heated speed vac, and resuspended in 1.5 ml of methanol for analysis. Prior to injection, the concentrated samples were filtered through a 0.45  $\mu\text{m}$  syringe filter.

*The Compounds Analyzed* – Based on the phenolics previously reported in the literature on cultivated potato, the following 19 compounds were selected for this analysis: Rutin hydrate, chlorogenic acid, gallic acid, protocatechuic acid, catechin, p-hydroxybenzoic acid, caffeic acid, vanillic acid, (-) epicatechin, p-coumaric acid, syringic acid, sinapic acid, 4'-5,7-Trihydroxyflavanone, ferulic acid, myricetin, salicylic acid, quercetin dihydrate, t-cinnamic acid, and kaempferol. All standard were obtained from Acros Organics (Pittsburgh, PA).

*The HPLC System*– The samples were run using Waters Melinnium 3.2 software on a system equipped with a binary pump system (Waters 515), an autoinjector (Waters

717 plus), a photodiode array (PDA) detector (Waters 996), and a column heater (SpectraPhysics SP8792). Compounds were separated on a 4.6 x 150 mm, 5 $\mu$ m, Atlantis C-18 reverse-phase column manufactured by Waters (Milford, MA), which was maintained at 40 C. The Atlantis column was chosen based on its ability to separate polar compounds using conventional reverse-phase chromatography. For analysis of phenolics, the following gradient system was used: Solvent A (Acetonitrile), solvent B (water/HCL, adjusted pH 2.3); gradient (min/%A) 0/85, 5/85, 30/0, 35/0. The column was brought back to initial conditions, and allowed to equilibrate for 11 minutes before the following injection (Appendix P). All solvents were filtered and degassed before use. Nine point calibration curves were prepared for all standards except tryptophan, and each was analyzed at its lambda max.

### ***Broad Screen for Carotenoid Content***

It has been reported in numerous studies that carotenoid content is highly correlated with the yellow intensity of tuber flesh, and as a result, this is frequently used as a measure of the carotenoid levels in potato (Lu *et al.* 2001; Haynes *et al.* 1994; Haynes *et al.* 1996; Haynes 2000; Janave and Thomas 1979). Based on a method published in *Current Protocols in Food Analytical Chemistry*, the carotenoids in the broad screen were determined by absorbance of the ethanol and hexane extracts at 445 nm and 450 nm, respectively (Scott 2001).

Standard curves were prepared for both the ethanol and hexane extracts to convert the absorbance into lutein and  $\beta$ -carotene equivalents, respectively. The lutein curve was

prepared by determining the absorbance at 445 nm of solutions of lutein ranging in concentration from .001-.02  $\mu\text{g}/\text{ml}$ . This curve allowed the determination of tuber carotenoid concentrations in the ethanol extract ranging from 0-2000  $\mu\text{g}/100\text{gfw}$  lutein equivalents. A similar curve was prepared for the hexane extract based on the absorbance of  $\beta$ -carotene at 450 nm. This curve allowed the determination of tuber carotenoid concentrations in the hexane extract ranging from 0-667  $\mu\text{g}/100\text{gfw}$   $\beta$ -carotene equivalents.

#### ***HPLC Analysis for Carotenoid Compounds***

Based on the results of the spectrophotometric broad screen for carotenoids, the top 10% of accessions were chosen for HPLC analysis.

*Concentrating the Samples* – Seven ml samples of the 10 g ethanol and hexane extracts were retained for analysis of individual carotenoid components by HPLC. The samples were dried to completion under a nitrogen stream and resuspended in 1 ml of 50% ethanol for analysis. Both prior to drying and following concentration, samples were filtered through a 0.45  $\mu\text{m}$  syringe filter.

*The Compounds Analyzed* – Based on previously reported studies on cultivated and diploid potatoes, the following seven carotenoids were selected for this analysis: Lutein, zeaxanthin,  $\beta$ -cryptoxanthin, antheraxanthin, canthaxanthin,  $\beta$ -carotene, and violaxanthin. The lutein, zeaxanthin, canthaxanthin, and  $\beta$ -cryptoxanthin were kindly provided by Hoffman La Roche (Basel, Switzerland),  $\beta$ -carotene was purchased from

Sigma-Aldrich, and antheraxanthin violaxanthin, and antheraxanthin were purchased from CaroteNature (Lupsingen, Switzerland).

*The HPLC System*– The samples were run using Waters Millennium 3.2 software using a system equipped with a binary pump system (Waters 515), an autoinjector (Waters 717plus), a photodiode array (PDA) detector (Waters 996), and a column heater (SpectraPhysics SP8792). Compounds were separated on a 4.6 x 250 mm, 5 $\mu$ m, YMC Carotenoid column (C-30 reverse-phase) purchased from Waters (Milford, MA), which was maintained at 35 C. The YMC carotenoid column was chosen based on its ability to separate lutein and zeaxanthin. For analysis of carotenoids, the following gradient system was used: methanol/water/triethylamine (90:10:0.1 v/v/v)(A), and methanol/MTBE/triethylamine (6:90:0.1 v/v/v)(B); gradient (min/%A) 0/99, 8/99, 45/0, 50/0, and 53/99 (Breithaupt and Bamedi 2002). The column was brought back to initial conditions, and allowed to equilibrate for 10 minutes before the following injection (Appendix Q). All solvents were filtered and degassed before use. All carotenoids were analyzed at 450 nm.

## **Results and Discussion**

The accessions from each shipment were processed simultaneously, and stored at –20C until extraction and analysis. The DPPH assay was performed first, followed by the HPLC phenolic analysis. While phenolic samples were run on the HPLC, carotenoid extractions were performed.

### ***DPPH Assay for Total Antioxidant Activity***

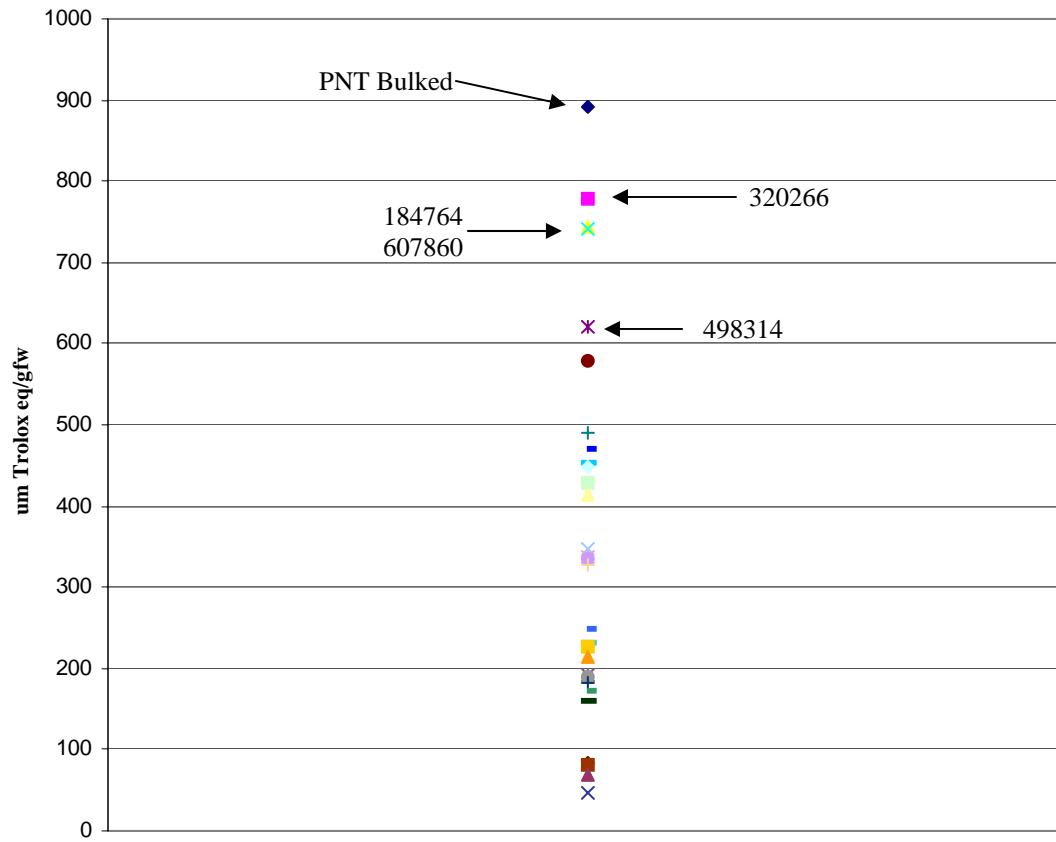
*Standard Curves for Ascorbic Acid and Trolox* – The standard curve for Trolox was estimated between 0 and 900  $\mu\text{M}$  Trolox. The resulting equation was as follows:  $y = 888.12x + 3.4883$  where  $y = \mu\text{g trolox equivalents/gfw}$  and  $x = \text{absorbance at } 515\text{nm}$ . The  $R^2$  value for this curve was 0.9977. The curve for ascorbic acid was prepared in the same manner, with the following regression equation:  $y = 853.82x - 0.2539$ , where  $y = \mu\text{g trolox equivalents/gfw}$  and  $x = \text{absorbance at } 515$ . The  $R^2$  value for this equation was 0.998. The values reported in subsequent discussion are based on the aforementioned equations.

*Bamberg 1* – A wide range of variation in antioxidant activity was found among the thirty accessions analyzed in the Bamberg 1 group. Antioxidant activity ranged from 48-892  $\mu\text{g trolox equivalents/gfw}$ , with an average value of 353. The same values converted to  $\mu\text{g ascorbic acid equivalents/gfw}$  ranged from 43-846, with an average value of 333. There was a 18-fold difference between the accession which was lowest in

antioxidant activity (PI 545832) and that which was highest (PNT Bulked) (Table 4-5).

Analysis of variance revealed significant differences between accessions ( $p < .0001$ ), while replications were insignificant ( $p = .2186$ ). Due to the number of accessions analyzed, mean separation analysis revealed little about which accessions would be useful in a breeding program to enhance antioxidant levels above what is already available in cultivated potato. Each grouping had far more accessions than parents desired, so the means were graphed in order to visually observe the distribution (Figure 4-2). The graph revealed 6 accessions that were above the rest of the cluster.

Interestingly, these six accessions were also above the cultivated potato samples, which were analyzed at the same time. Significantly different from most other accessions was a bulked sample of *S. pinnatisectum* (892  $\mu\text{g trolox/gfw}$ ). Following this accession were *S. comersonii* 320266 (778  $\mu\text{g trolox/gfw}$ ), *S. pinnatisectum* 184764 (744  $\mu\text{g trolox/gfw}$ ), *S. oxycarpum* 607860 (742  $\mu\text{g trolox/gfw}$ ), *S. jamesii* 564050 (622  $\mu\text{g trolox/gfw}$ ), and *S. violaceimarmoratum* 498314 (580  $\mu\text{g trolox/gfw}$ ).



**FIGURE 4-2.**  
**Distribution of accessions analyzed in Bamberg 1 group.**

TABLE 4-5 – Antioxidant activities of Bamberg 1 accessions.

Accession	Species	ug Trolox eq/gfw
PNT bulked	<i>pinnatisectum</i>	892
PI 320266	<i>commersonii</i>	778
PI 184764	<i>pinnatisectum</i>	744
PI 607860	<i>oxycarpum</i>	742
PI 564050	<i>jamesii</i>	622
PI 498314	<i>violaceimarmoratum</i>	580
PI 568929	<i>bukasovii</i>	489
PI 607866	<i>brachycarpum</i>	471
PI 310993	<i>lignicaule</i>	454
PI 458374	<i>vernei</i>	448
PI 597732	<i>megistacrolobum</i>	429
PI 320342	<i>polyadenium</i>	413
PI 320316	<i>microdontum</i>	347
PI 595507	<i>berthaultii</i>	338
PI 473412	<i>commersonii</i>	335
PI 47310A	<i>med</i>	328
PI 558464	<i>demissum</i>	248
PI 558404	<i>hougasii</i>	232
PI 597721	<i>hoopesii</i>	228
PI 564029	<i>fenderli</i>	228
PI 558101	<i>oplocense</i>	213
PI 597753	<i>hoopesii</i>	193
PI 473086	<i>gourlayi</i>	192
PI 604040	<i>alandiae</i>	191
PI 597767	<i>sparsipilum</i>	183
PI 255545	<i>polytrichon</i>	173
PI 283088	<i>laxissimum</i>	159
PI 545828	<i>nayaritense</i>	84
PI 597710	<i>oplocense</i>	81
PI 545832	<i>brachistotrichum</i>	48



*Bamberg 2* – A wide range of variation in antioxidant activity was found among the 65 accessions analyzed in the Bamberg 2 group. Antioxidant activity ranged from 160-847  $\mu\text{g}$  trolox equivalents/gfw, with an average value of 530. The same values converted to  $\mu\text{g}$  ascorbic acid equivalents/gfw ranged from 150-803, with an average value of 501 (Table 4-6). There was a five-fold difference between the accession which was lowest in antioxidant activity (*S. megistacrolobum* 265873), and that which was highest (*S. spgazzinii* 500053). Many accessions were higher than the cultivated genotypes analyzed. Analysis of variance revealed significant differences between accessions ( $p < .0001$ ), species ( $p = .0332$ ), and replications ( $p = .0069$ ), but not between field replications ( $p = .6229$ ).

*Bamberg 02* – Based on the mixed populations analyzed in the Bamberg 1 and Bamberg 2 screens for antioxidant activity, accessions and species which had been consistently high were chosen for analysis of individual clones grown from tuber seed within these populations.

TABLE 4-6 – Antioxidant activities of Bamberg 2 accessions.

Accession number	Species	µgTrolox eq/gfw	Accession number	Species	µgTrolox eq/gfw
PI 500053	<i>spgazzinii</i>	847	PI 545725	<i>papita</i>	455
PI 498383	<i>megistacrolobum</i>	827	PI 310956	<i>canasense</i>	446
PI 347766	<i>pinnantisectum</i>	819	PI 265863	<i>canasense</i>	432
PI 197760	<i>chacoense</i>	818	PI 473185	<i>oplocense</i>	414
PI 275236	<i>pinnantisectum</i>	816	PI 498359	<i>kurtzianum</i>	408
PI 184774	<i>pinnantisectum</i>	815	PI 472941	<i>kurtzianum</i>	407
PI 473481	<i>acaule</i>	811	PI 243513	<i>bulbocastanum</i>	400
PI 320293	<i>chacosense</i>	804	PI 275187	<i>bulbocastanum</i>	391
PI 160208	<i>demissum</i>	802	PI 498033	<i>papita</i>	389
PI 472661	<i>acaule</i>	796	PI 473243	<i>tarijense</i>	383
PI 218225	<i>microdontum</i>	786	PI 184770	<i>polytrichon</i>	379
PI 275262	<i>jamesii</i>	779	PI 265867	<i>infundibuliforme</i>	375
PI 497998	<i>fendleri</i>	734	PI 205407	<i>spgazzinii</i>	373
PI 498351	<i>infundibuliforme</i>	718	PI 472923	<i>Kurtzianum</i>	372
PI 435079	<i>oplocense</i>	701	PI 500041	<i>microdontum</i>	364
PI 195190	<i>jamesii</i>	689	PI 472986	<i>spgazzinii</i>	299
PI 265579	<i>gourlayi</i>	689	PI 347773	<i>tuberosum</i>	298
PI 473190	<i>oplocense</i>	676	PI 249929	<i>papita</i>	287
PI 500047	<i>acaule</i>	666	PI 195204	<i>stenotomum</i>	268
PI 473336	<i>tarijense</i>	656	PI 597710	<i>oplocense</i>	249
PI 243503	<i>commersonii</i>	638	PI 472894	<i>infundibuliforme</i>	237
PI 498004	<i>fendleri</i>	636	PI 195206	<i>tarijense</i>	233
PI458425	<i>jamesii</i>	635	PI 498057	<i>stoloniferum</i>	202
PI 473062	<i>gourlayi</i>	613	PI 255547	<i>polytrichon</i>	197
PI 498232	<i>demissum</i>	605	PI 265873	<i>megistacrolobum</i>	160
PI 472842	<i>commersonii</i>	586			
PI 320316	<i>microdontum</i>	573			
PI 230589	<i>demissum</i>	573			
PI 205510	<i>stoloniferum</i>	559			
PI 473411	<i>commersonii</i>	553			
PI 500049	<i>gourlayi</i>	532			
PI 473133	<i>megistacrolobum</i>	530			
PI 161173	<i>verrucosum</i>	529			
PI 275156	<i>fendleri</i>	527			
PI 498039	<i>polytrichon</i>	512			
PI 283109	<i>stoloniferum</i>	497			
PI 545751	<i>bulbocastanum</i>	487			
PI 275139	<i>chacoense</i>	468			
PI 473345	<i>canasense</i>	440			
PI 473171	<i>microdontum</i>	436			

Since the overall objective of the study was to increase antioxidant levels consumed in the diet through potato, preference was given to those species that can be easily crossed with *S. tuberosum*. Large numbers of individual clones from families which were high in antioxidant activity in the Bamberg 1 and Bamberg 2 groups, in addition to species which performed well in these screens, and other accessions of interest, were screened in 2002.

Antioxidant activity of the clones screened in 2002 ranged from 43-884  $\mu\text{g}$  trolox equivalents/gfw, with an average value of 338.32. The same values, converted to  $\mu\text{g}$  ascorbic acid equivalents/gfw ranged from 150-803. There was a 21-fold difference between the accession that was lowest in antioxidant activity and the accession that was highest. Analysis of variance revealed significant differences between accessions ( $p < .0001$ ), while replications were insignificant ( $p = .1230$ ). *S. pinnatisectum* and *S. jamesii* clones were consistently high in antioxidant activity, while *S. brachistotrichum* continually ranked low. Clones of *S. jamesii* accession 275262 appeared to be consistently high in antioxidant activity (Table 4-7).

TABLE 4-7 - Antioxidant activities of Bamberg 02 accessions.

Accession	ID	Species	$\mu\text{g trolox eq/gfw}$
341235	TAX 72	<i>cardiophyllum</i>	884
320266	320266.17	<i>commersonii</i>	882
275262	AO 28.10	<i>jamesii</i>	880
275234	HERB 10.1-.3	<i>pinnatisectum</i>	880
275231	HERB 7.1-.9	<i>pinnatisectum</i>	873
347766	HERB 13.1-.9	<i>pinnatisectum</i>	872
275232	HERB 8.1-.8	<i>pinnatisectum</i>	870
230489	HERB 4.1-.9	<i>pinnatisectum</i>	869
275262	AO 28.13	<i>jamesii</i>	869
341233	TAX 71	<i>cardiophyllum</i>	869
190115	TAX 30	<i>pinnatisectum</i>	867
275233	HERB 9.1-.9	<i>pinnatisectum</i>	867
537023	HERB 14.1-.7	<i>pinnatisectum</i>	866
184774	HERB1.1-.6	<i>pinnatisectum</i>	865
275236	TAX 33	<i>pinnatisectum</i>	863
184774	FFAO 52	<i>pinnatisectum</i>	862
253214	HERB 5.1-.8	<i>pinnatisectum</i>	861
275230	HERB 6.1-.9	<i>pinnatisectum</i>	861
275235	HERB 11.1-.9	<i>pinnatisectum</i>	858
275232	TAX 32	<i>pinnatisectum</i>	858
275236	HERB 12.1-.9	<i>pinnatisectum</i>	857
275262	AO 28.4	<i>jamesii</i>	856
275231	TAX 31	<i>pinnatisectum</i>	850
498383	AO 39.5	<i>megistacrolobum</i>	844
275262	AO 28.11	<i>jamesii</i>	832
275262	AO 28.2	<i>jamesii</i>	823
275262	AO 28.7	<i>jamesii</i>	819
275262	AO 28.16	<i>jamesii</i>	809
275262	AO 28.9	<i>jamesii</i>	808
498383	AO 39.10	<i>megistacrolobum</i>	794
275262	AO 28.8	<i>jamesii</i>	789
275262	AO 28.6	<i>jamesii</i>	783
612456	TAX 142	<i>jamesii</i>	764
275262	AO 28.3	<i>jamesii</i>	763
605371	TAX 141	<i>jamesii</i>	760
275262	AO 28.5	<i>jamesii</i>	743
190115	HERB 3.1-.7	<i>pinnatisectum</i>	700
197760	AO 10.3	<i>chacoense</i>	685
275262	AO 28.1	<i>jamesii</i>	684
595478	TAX 145	<i>sambucinum</i>	653

TABLE 4-7 - *continued*

<b>Accession ID</b>	<b>Species</b>	<b>µg trolox eq/gfw</b>	
473243	FFAO 68	<i>tarijense</i>	642
197760	AO 10.7	<i>chacoense</i>	626
186553	HERB 2.1-.9	<i>pinnatisectum</i>	623
275262	AO 28.15	<i>jamesii</i>	596
218225	AO 34.18	<i>microdontum</i>	591
320266	F2 4.18	<i>commersonii</i>	588
283109	FFAO 65	<i>stoloniferum</i>	584
500053	AO 60.7	<i>spgazzinii</i>	537
218225	AO 34.17	<i>microdontum</i>	521
473336	FFAO 69	<i>tarijense</i>	480
275262	AO 28.12	<i>jamesii</i>	478
472871	EV 802	<i>infundibuliforme</i>	473
458425	FFAO 29	<i>jamesii</i>	469
320266	F2 5.4	<i>commersonii</i>	465
218225	FFAO 34	<i>microdontum</i>	464
197760	AO 10.14	<i>chacoense</i>	458
218225	AO 34.14	<i>microdontum</i>	450
472986	FFAO 59	<i>spgazzinii</i>	439
458322	EV 782	<i>infundibuliforme</i>	430
218225	AO 34.3	<i>microdontum</i>	423
472869	EV 800	<i>infundibuliforme</i>	420
230512	FFAO 62	<i>stenotomum</i>	413
320266	F2 5.2	<i>commersonii</i>	409
320266	F2 5.11	<i>commersonii</i>	408
197760	AO 10.17	<i>chacoense</i>	402
218225	AO 34.7	<i>microdontum</i>	399
197760	AO 10.4	<i>chacoense</i>	396
320266	F2 4.5	<i>commersonii</i>	394
218225	AO 34.5	<i>microdontum</i>	393
197760	AO 10.13	<i>chacoense</i>	391
218225	AO 34.16	<i>microdontum</i>	390
320266	F2 4.17	<i>commersonii</i>	382
498333	EV 850	<i>infundibuliforme</i>	380
205510	FFAO 64	<i>stoloniferum</i>	376
218225	AO 34.13	<i>microdontum</i>	369
197760	AO 10.16	<i>chacoense</i>	368
320266	F2 4.12	<i>commersonii</i>	368
218225	AO 34.15	<i>microdontum</i>	360
500053	AO 60.13	<i>spgazzinii</i>	360
197760	AO 10.9	<i>chacoense</i>	357
472898	EV 826	<i>infundibuliforme</i>	354
275262	AO 28.14	<i>jamesii</i>	353
197760	AO 10.15	<i>chacoense</i>	342

TABLE 4-7 - *continued*

Accession	ID	Species	$\mu\text{g trolox eq/gfw}$
498345	EV 862	<i>infundibuliforme</i>	341
197760	AO 10.12	<i>chacoense</i>	338
197760	AO 10.10	<i>chacoense</i>	338
255519	TAX 60	<i>cardiophyllum</i>	337
500046	EV 873	<i>infundibuliforme</i>	336
320266	F2 5.8	<i>commersonii</i>	334
197760	AO 10.8	<i>chacoense</i>	333
500053	AO 60.4	<i>spgazzinii</i>	330
320295	EV 772	<i>infundibuliforme</i>	330
500053	AO 60.14	<i>spgazzinii</i>	329
218225	AO 34.4	<i>microdontum</i>	327
498383	AO 39.16	<i>megistacrolobum</i>	326
320266	320266.2	<i>commersonii</i>	326
197760	AO 10.11	<i>chacoense</i>	323
320266	F2 4.10	<i>commersonii</i>	323
320266	F2 4.2	<i>commersonii</i>	322
320266	F2 4.9	<i>commersonii</i>	319
472876	EV 806	<i>infundibuliforme</i>	317
498383	AO 39.18	<i>megistacrolobum</i>	314
500053	AO 60.2	<i>spgazzinii</i>	306
320265	TAX 45	<i>brachistotrichum</i>	306
265863	FFAO 7,8,9	<i>canasense</i>	305
197760	AO 10.5	<i>chacoense</i>	301
498383	AO 39.11	<i>megistacrolobum</i>	298
320266	F2 4.6	<i>commersonii</i>	296
472862	EV 793	<i>infundibuliforme</i>	294
472886	EV 816	<i>infundibuliforme</i>	293
442676	EV 778	<i>infundibuliforme</i>	291
473171	FFAO 35	<i>microdontum</i>	291
320266	F2 4.3	<i>commersonii</i>	288
414147	EV 774	<i>infundibuliforme</i>	288
498351	EV 868	<i>infundibuliforme</i>	281
500053	AO 60.6	<i>spgazzinii</i>	281
435076	EV 776	<i>infundibuliforme</i>	281
500053	AO 60.16	<i>spgazzinii</i>	281
473190	FFAO 42	<i>oplocense</i>	279
265873	FFAO 37	<i>megistacrolobum</i>	277
472892	EV 820	<i>infundibuliforme</i>	275
283062	TAX 68	<i>cardiophyllum</i>	274
472860	EV 791	<i>infundibuliforme</i>	273
472915	EV 840	<i>infundibuliforme</i>	273
218225	AO 34.12	<i>microdontum</i>	272
595486	TAX 85	<i>cardiophyllum</i>	272

TABLE 4-7 - *continued*

<b>Accession ID</b>	<b>Species</b>	<b>µg trolox eq/gfw</b>	
320266	F2 5.6	<i>commersonii</i>	271
498383	AO 39.6	<i>megistacrolobum</i>	271
458325	EV 785	<i>infundibuliforme</i>	269
472882	EV 812	<i>infundibuliforme</i>	267
592422	FFAO 30	<i>jamesii</i>	266
320266	F2 4.15	<i>commersonii</i>	265
498354	EV 870	<i>infundibuliforme</i>	265
473522	EV 846	<i>infundibuliforme</i>	263
472856	EV 787	<i>infundibuliforme</i>	263
320266	F2 5.1	<i>commersonii</i>	263
320266	F2 4.7	<i>commersonii</i>	262
498383	AO 39.14	<i>megistacrolobum</i>	261
498383	AO 39.17	<i>megistacrolobum</i>	261
500053	AO 60.3	<i>spgazzinii</i>	260
566769	EV 883	<i>infundibuliforme</i>	259
472913	EV 838	<i>infundibuliforme</i>	258
283063	TAX 69	<i>cardiophyllum</i>	256
500053	AO 60.8	<i>spgazzinii</i>	255
320266	F2 5.9	<i>commersonii</i>	255
472888	EV 818	<i>infundibuliforme</i>	252
500053	AO 60.15	<i>spgazzinii</i>	251
320266	F2 4.4	<i>commersonii</i>	246
205407	FFAO 58	<i>spgazzinii</i>	245
595476	TAX 80	<i>cardiophyllum</i>	243
218225	AO 34.6	<i>microdontum</i>	243
498341	EV 858	<i>infundibuliforme</i>	242
500053	AO 60.12	<i>spgazzinii</i>	240
218225	AO 34.2	<i>microdontum</i>	240
498339	EV 856	<i>infundibuliforme</i>	239
320266	F2 4.11	<i>commersonii</i>	239
320266	F2 5.5	<i>commersonii</i>	238
320266	F2 6.1	<i>commersonii</i>	238
218225	AO 34.8	<i>microdontum</i>	235
320266	F2 4.8	<i>commersonii</i>	235
498383	AO 39.9	<i>megistacrolobum</i>	235
472878	EV 808	<i>infundibuliforme</i>	234
545725	FFAO 57	<i>papita</i>	233
498383	AO 39.12	<i>megistacrolobum</i>	233
500053	AO 60.11	<i>spgazzinii</i>	233
197760	AO 10.6	<i>chacoense</i>	232
498343	EV 860	<i>infundibuliforme</i>	231
545894	EV 875	<i>infundibuliforme</i>	231
595467	TAX 78	<i>cardiophyllum</i>	230

TABLE 4-7 - *continued*

<b>Accession ID</b>	<b>Species</b>	<b>µg trolox eq/gfw</b>	
320266	F2 5.7	<i>commersonii</i>	225
472873	EV 804	<i>infundibuliforme</i>	225
473481	FFAO-2	<i>acaule</i>	224
558401	TAX 55	<i>brachistotrichum</i>	222
472846	EV 691	<i>commersonii</i>	220
275184	TAX 6	<i>bulbocastanum</i>	219
500041	FFAO 36	<i>microdontum</i>	219
195206	FFAO 67	<i>tarijense</i>	217
500053	AO 60.10	<i>spgazzinii</i>	217
218225	AO 34.10	<i>microdontum</i>	217
472884	EV 814	<i>infundibuliforme</i>	216
500049	FFAO 24	<i>gourlayi</i>	216
500053	AO 60.9	<i>spgazzinii</i>	213
500053	AO 60.18	<i>spgazzinii</i>	210
500053	AO 60.5	<i>spgazzinii</i>	207
347759	TAX 73	<i>cardiophyllum</i>	207
320266	320266.1	<i>commersonii</i>	207
472896	EV 824	<i>infundibuliforme</i>	205
472917	EV 842	<i>infundibuliforme</i>	203
498130	FFAO 47	<i>okadae</i>	201
472901	EV 828	<i>infundibuliforme</i>	200
566767	EV 881	<i>infundibuliforme</i>	200
472894	EV 822	<i>infundibuliforme</i>	199
320266	320266.16	<i>commersonii</i>	195
497993	TAX 46	<i>brachistotrichum</i>	195
320266	F2 6.2	<i>commersonii</i>	193
320266	F2 5.12	<i>commersonii</i>	191
275212	TAX 62	<i>cardiophyllum</i>	188
500053	AO 60.17	<i>spgazzinii</i>	187
498383	AO 39.1	<i>megistacrolobum</i>	184
472909	EV 836	<i>infundibuliforme</i>	183
558460	TAX 56	<i>brachistotrichum</i>	181
498383	AO 39.13	<i>megistacrolobum</i>	176
558483	TAX 150	<i>verrucosum</i>	175
341231	TAX 70	<i>cardiophyllum</i>	173
498383	AO 39.7	<i>megistacrolobum</i>	172
275214	TAX 64	<i>cardiophyllum</i>	171
472923	FFAO 31	<i>kurtzianum</i>	167
545752	TAX 12	<i>bulbocastanum</i>	167
251720	TAX 40	<i>brachistotrichum</i>	166
320266	320266.7	<i>commersonii</i>	165
320266	F2 6.17	<i>commersonii</i>	165
498039	FFAO 51	<i>polytrichon</i>	164



TABLE 4-7 - *continued*

<b>Accession ID</b>	<b>Species</b>	<b>µg trolox eq/gfw</b>
184770	<i>FFAO 49 polytrichon</i>	161
473414	<i>EV 844 infundibuliforme</i>	160
597678	<i>TAX 88 cardiophyllum</i>	158
472907	<i>EV 834 infundibuliforme</i>	155
218225	<i>AO 34.9 microdontum</i>	155
498383	<i>AO 39.3 megistacrolobum</i>	154
320266	<i>F2 4.14 commersonii</i>	154
320266	<i>F2 4.13 commersonii</i>	154
320266	<i>F2 6.11 commersonii</i>	151
498383	<i>AO 39.2 megistacrolobum</i>	150
595482	<i>TAX 84 cardiophyllum</i>	148
595480	<i>TAX 83 cardiophyllum</i>	146
472880	<i>EV 810 infundibuliforme</i>	146
498383	<i>AO 39.4 megistacrolobum</i>	137
320293	<i>FFAO 12 chacoense</i>	137
255520	<i>TAX 61 cardiophyllum</i>	136
275213	<i>TAX 63 cardiophyllum</i>	133
472941	<i>FFAO 32 kurtzianum</i>	133
472903	<i>EV 830 infundibuliforme</i>	131
498217	<i>TAX 48 brachistotrichum</i>	130
595488	<i>TAX 86 cardiophyllum</i>	129
320266	<i>320266.5 commersonii</i>	127
275216	<i>TAX 66 cardiophyllum</i>	127
595489	<i>TAX 87 cardiophyllum</i>	126
498335	<i>EV 852 infundibuliforme</i>	125
590921	<i>EV 695 commersonii</i>	122
255527	<i>TAX 41 brachistotrichum</i>	118
498337	<i>EV 854 infundibuliforme</i>	117
498383	<i>AO 39.15 megistacrolobum</i>	116
186548	<i>TAX 59 cardiophyllum</i>	115
498383	<i>AO 39.8 megistacrolobum</i>	110
197760	<i>FFAO 10 chacoense</i>	108
243510	<i>FFAO 4 bulbocastanum</i>	107
558460	<i>TAX 56B brachistotrichum</i>	106
611104	<i>TAX 198 edinense</i>	102
184771	<i>TAX 58 cardiophyllum</i>	100
184762	<i>TAX 57 cardiophyllum</i>	98
545751	<i>FFAO 6 bulbocastanum</i>	98
275139	<i>FFAO 11 chacoense</i>	97
255547	<i>FFAO 50 polytrichon</i>	96
275187	<i>FFAO 5 bulbocastanum</i>	95
545824	<i>TAX 76 cardiophyllum</i>	88
558379	<i>TAX 13 bulbocastanum</i>	81

TABLE 4-7 - *continued*

<b>Accession ID</b>	<b>Species</b>	<b>µg trolox eq/gfw</b>
545753 TAX 74	<i>cardiophyllum</i>	78
320266 F2 6.16	<i>commersonii</i>	74
545817 TAX 53	<i>brachistotrichum</i>	69
545832 TAX 54	<i>brachistotrichum</i>	66
545814 TAX 51	<i>brachistotrichum</i>	65
545827 TAX 144	<i>nyaritense</i>	61
545820 TAX 143	<i>nyaritense</i>	61
545812 TAX 49	<i>brachistotrichum</i>	59
255529 TAX 43	<i>brachistotrichum</i>	59
545813 TAX 50	<i>brachistotrichum</i>	55
255530 TAX 44	<i>brachistotrichum</i>	51
545815 TAX 52	<i>brachistotrichum</i>	48
255528 TAX 42	<i>brachistotrichum</i>	43

*Jamesii* Samples – In addition to the broad screen of species, 50 *S. jamesii* accessions were analyzed for antioxidant activity. While the range in variation among the *S. jamesii* samples was lower than that for any other group, the mean was the highest among the Bamberg samples. Furthermore, the mean of the *S. jamesii* samples was higher than the highest tetraploid genotype tested. Antioxidant activity ranged from 365-871 µg trolox equivalents/gfw, with an average value of 662. Analysis of variance revealed significant differences between both accessions ( $p < .0001$ ) and replications ( $p = .0295$ ). Accessions with antioxidant activities above 800 µg trolox equivalents/gfw, which is exceptionally high considering the highest tetraploid genotype analyzed (see chapter III) had an antioxidant activity of 648, include PI 603056, PI 595784, PI 603055, PI 275172, PI 275266, PI 275262, PI 458424, PI 592399, and PI 275264.

### *HPLC Analysis of Phenolic Compounds*

Based on results of the DPPH analysis, the top 10% of accessions in antioxidant activity were analyzed, in triplicate, via HPLC. At the beginning of this study, HPLC analysis of phenolics was not anticipated, thus only the Bamberg 2, Bamberg 02, and Jamesii accessions were included in this analysis.

*Bamberg 2* – The accessions included in the Bamberg 2 HPLC analysis were the accessions ranked in the top 10% in antioxidant activity (high), the accessions which were the lowest (low) in antioxidant activity, and accessions representing several species (species) that were not included in the top 10%. When available, tubers from two locations in the field (field replications) were analyzed. Accessions included in the top 10% were PI 184774 (*S. pinnatisectum*), PI 197760 (*S. chacoense*), PI 275236 (*S. pinnatisectum*), PI 347766 (*S. pinnatisectum*), PI 473781 (*S. acaule*), PI 498383 (*S. megistacrolobum*), and PI 500053 (*S. spegazzinii*). Accessions low in activity, which were analyzed to determine the range of phenolics contained in wild species were PI 195204 (*S. stenotomum*), and PI 249929 (*S. papita*). Since *S. pinnatisectum* and *S. jamesii* dominated the top 10%, it was possible that accessions high in one particular compound (though not total activity) would be overlooked if only the top 10% were examined via HPLC.

To reduce the possibility of overlooking an accession that could contribute to the level of one particular compound when used as parents, a survey of species were analyzed via HPLC. Accessions included in this survey were PI 265579 (*S. gourlayi*), PI

430579 (*S. oplocense*), PI 473781 (*S. acaule*), PI 497998 (*S. fendleri*), PI 498232 (*S. demissum*), and PI 545725 (*S. papita*). As discovered in previous studies on cultivated varieties, the primary phenolics identified in the tubers were chlorogenic and caffeic acids, which were both present in all but one of the accessions analyzed. Salicylic acid and p-coumaric acid were identified in some of the accessions as well. Chlorogenic acid levels ranged from 0-1836  $\mu\text{g/gfw}$ , while caffeic acid levels ranged from 45-149  $\mu\text{g/gfw}$ . Total phenolic levels, calculated by adding up the individual compounds quantified, ranged from 37-1967  $\mu\text{g/gfw}$  (Table 4-8). These levels have a much greater range than those found in tetraploid *S. tuberosum* (See chapter III). The values in cultivated *S. tuberosum*, obtained by the same extraction and HPLC method, ranged from 26-341  $\mu\text{g chlorogenic acid/gfw}$ , 33-41  $\mu\text{g caffeic acid/gfw}$ , and 60-396  $\mu\text{g total phenolics/gfw}$ . Analysis of variance for chlorogenic acid revealed significant differences between accessions ( $p < .0001$ ), while no differences were found between replications ( $p = .7427$ ), or field replications ( $p = .0795$ ). PI 347766 was significantly higher in chlorogenic acid content than all other accessions but PI 275236. PI 275236 was significantly different than all other accessions except PI 184774 and PI 347766 (Table 4-9). It is noted that all of the accessions that were high in antioxidant activity in the broad screen, were also high in chlorogenic acid. A correlation analysis was performed between the results from the DPPH assay and chlorogenic acid content as quantified via HPLC analysis. Pearson's correlation coefficient was calculated as 0.63, and linear regression revealed that 40% of the variability in the DPPH analysis could be explained by chlorogenic acid content.

TABLE 4-8 – HPLC phenolic results for Bamberg 2.

ACNO	Species	Group	Field Rep	Caffeic Acid (µg/gfw)	Chlorogenic Acid (µg/gfw)	p-coumaric acid (µg/gfw)	Salicylic Acid (µg/gfw)	Total Phenolics (µg/gfw)
347766	<i>pinnatisectum</i>	high	1	149	1818			1967
275236	<i>pinnatisectum</i>	high	2	120	1475			1595
197660	<i>chacoense</i>	high	2	170	1134			1304
275236	<i>pinnatisectum</i>	high	1	127	1022			1149
347766	<i>pinnatisectum</i>	high	2	123	969			1092
184774	<i>pinnatisectum</i>	high	2	126	836		6	968
498232	<i>demissum</i>	species	2	90	746	9		845
184774	<i>pinnatisectum</i>	high	1	102	695			797
498383	<i>megistacrolobum</i>	high	2	48	702			750
498383	<i>megistacrolobum</i>	high	1	40	451			491
473781	<i>acaule</i>	species	1	90	370			460
430579	<i>oplocense</i>	species	2	55	401			455
265579	<i>gourlayi</i>	species	1	53	330			383
473781	<i>acaule</i>	high	2	51	314			365
497998	<i>fendleri</i>	species	1	50	292			342
265579	<i>gourlayi</i>	species	2	44	221	44		309
430579	<i>oplocense</i>	species	1	56	225	18		299
197660	<i>chacoense</i>	high	1	71	155			226
249929	<i>papita</i>	low	2	47	157			204
497998	<i>fendleri</i>	species	2	48	151			200
545725	<i>papita</i>	species	2	47	94			141
249929	<i>papita</i>	low	1	44	91			135
545725	<i>papita</i>	species	1	45	78			123
498232	<i>demissum</i>	species	1	44	78			122
195204	<i>stenotomum</i>	low	1	36	45			82
500053	<i>spgazzinii</i>	high	2	37				37

TABLE 4-9 – Mean separation for levels of chlorogenic acid contained in Bamberg 2.

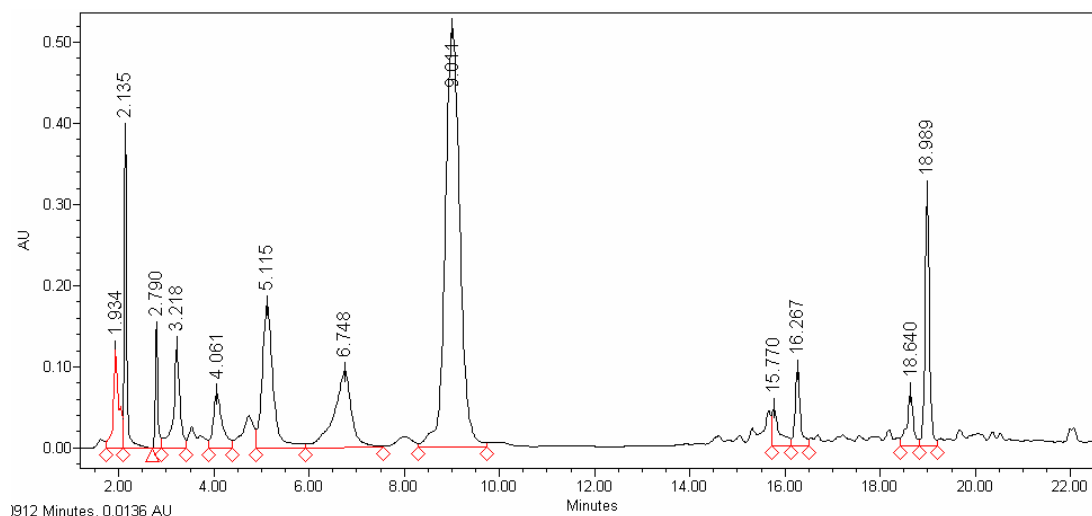
<b>ACNO</b>	<b>Species</b>	<b>Group</b>	<b>µg chlorogenic acid/gfw</b>	<b>Tukey's Grouping</b>
347766	<i>pinnatisectum</i>	high	1606	a
275236	<i>pinnatisectum</i>	high	1316	ab
184774	<i>pinnatisectum</i>	high	779	bc
197660	<i>chacoense</i>	high	645	cd
498383	<i>megistacrolobum</i>	high	551	cde
498232	<i>demissum</i>	species	412	cde
473781	<i>acaule</i>	species	356	cde
430579	<i>oplocense</i>	species	286	cde
265579	<i>gourlayi</i>	species	269	cde
497998	<i>fendleri</i>	species	222	cde
249929	<i>papita</i>	low	118	de
545725	<i>papita</i>	species	87	de
195204	<i>stenotomum</i>	low	45	e

Analysis of variance for caffeic acid revealed significant differences between accessions ( $p < .0001$ ), while no differences were observed between replications ( $p = .8326$ ) or field replications ( $p = .0827$ ). PI 347766 (*pinnatisectum*) was significantly higher in caffeic acid content than all other accessions except PI 197660 (*chacoense*), PI 184774 (*pinnatisectum*), and PI 275236 (*pinnatisectum*) (Table 4-10).

TABLE 4-10 – Mean separation of levels of caffeic acid contained in Bamberg 2.

<b>Accession</b>	<b>Species</b>	<b>Group</b>	<b>µg caffeic acid/gfw</b>	<b>Tukey's Grouping</b>
347766	<i>pinnatisectum</i>	high	142	a
197660	<i>chacoense</i>	high	121	ab
184774	<i>pinnatisectum</i>	high	116	ab
275236	<i>pinnatisectum</i>	high	116	ab
473781	<i>acaule</i>	species	80	bc
498232	<i>demissum</i>	species	62	c
430579	<i>oplocense</i>	species	56	c
265579	<i>gourlayi</i>	species	49	c
497998	<i>fendleri</i>	species	49	c
545725	<i>papita</i>	species	46	c
249929	<i>papita</i>	low	45	c
498383	<i>megistacrolobum</i>	high	43	c
195204	<i>stenotomum</i>	low	36	c

As with chlorogenic acid, when accessions were ranked according to caffeic acid content, all of the species, with the exception of one, that were high in antioxidant activity ranked at the top in caffeic acid content. A correlation analysis was performed between the results from the DPPH assay and caffeic acid as quantified via HPLC analysis, giving almost identical results to the results found for chlorogenic acid. Pearson's correlation coefficient was calculated as 0.62, and linear regression revealed that 40% of the variability in the DPPH assay could be explained by caffeic acid content. PI 184774 (*pinnatisectum*) contained 6µg/gfw salicylic acid, while PI 265579 (*gourlayi*), PI 430579 (*oplocense*), and PI 498232 (*demissum*) contained 44, 18, and 9 ug/gfw p-coumaric acid, respectively. A typical chromatogram is shown in Figure 4-3.



**FIGURE 4-3.**

**A typical chromatogram of phenolic separation of the wild species. The accession pictured is PI 275236 (*S. pinnatisectum*).**

*Bamberg 02* – The genotypes included in the Bamberg 02 HPLC analysis included accessions ranked in the top 10% in antioxidant activity (high), the accessions which were the lowest in antioxidant activity (low), and accessions representing several other species (species). Accessions included in the HPLC analysis are listed in Table 4-11. As in the Bamberg 2 analysis, chlorogenic acid and caffeic acid were identified in tubers; however vanillic acid was also quite abundant. Other compounds identified included p-coumaric acid, epicatechin, t-cinnamic acid, rutin hydrate, and gallic acid. Chlorogenic acid levels ranged from 18-1117  $\mu\text{g/gfw}$ , while caffeic acid levels ranged from 34-1570  $\mu\text{g/gfw}$ . These levels have a much greater range than those found in



tetraploid *S. tuberosum*, with values ranging from 26-341 µg chlorogenic acid/gfw, and 33-41 µg caffeic acid/gfw. Analysis of variance for chlorogenic acid, caffeic acid, and vanillic acid as well as the total phenolic levels, revealed significant differences between accessions, while no differences were found between replications. PI 184774 (*pinnatisectum*) was significantly different in caffeic acid from all other accessions analyzed. As in the Bamberg 2 samples, the varieties that were high in antioxidant activity were also high in chlorogenic and caffeic acids. *S. pinnatisectum* accessions were consistently high in caffeic and chlorogenic acid, and many also contained measurable levels of vanillic acid. Vanillic acid had a small range of concentration, ranging from 6-17 µg/gfw. Accessions containing p-coumaric acid included PI 283109 (*S. stoloniferum*), PI 275231 (*S. pinnatisectum*), PI 498383 (*S. megistracrolobum*), PI 275262 (*S. jamesii*), PI 341233 (*S. cardiophyllum*), PI 341235 (*S. cardiophyllum*), PI 595478 (*S. sambucinum*), PI 595486 (*S. cardiophyllum*), and PI 320265 (*S. brachistrotrichum*). Accessions containing epicatechin included PI 341235 (*S. cardiophyllum*), PI 545813 (*S. brachistrotrichum*). Trans-cinnamic acid was identified in 3 accessions and ranged from 11-127 µg/gfw. These accessions included PI 275230 (*S. pinnatisectum*), PI 473190 (*S. oplocense*), and PI 341325 (*S. cardiophyllum*). Rutin hydrate was identified in PI 283109 (*S. stoloniferum*), PI 473481 (*S. acaule*), and PI 500049 (*S. gourlayi*). While gallic acid was only identified in one accession (PI 255530, *brachistortrichum*), it is possible that it was contained in other accessions as well.

Due to its immediate elution from the column, it co-eluted with the void volume, therefore, the spectra was frequently contaminated by other compounds. Compounds were only quantitated if they matched both the retention time and spectra of the standard compounds. Had the analysis been based solely on retention time, gallic acid, and may other compounds, would have been identified and quantified.

*Jamesii Samples* – *Jamesii* accessions ranking in the top 10% from the DPPH assay were analyzed for individual carotenoid components by HPLC. Caffeic acid levels ranged from 157-268  $\mu\text{g/gfw}$ , while chlorogenic acid levels ranged from 65-105  $\mu\text{g/gfw}$ . One accession, PI 603056 contained 9  $\mu\text{g}$  vanillic acid/gfw. Total phenolic content ranged from 164-356  $\mu\text{g/gfw}$  (Table 4-12). Since the accessions contained in this group of samples were segregating populations, grown from true botanical seed, the values are not the same as those reported in Bamberg 02. Further differences could be a result of environment on levels of antioxidant compounds since the Bamberg 02 samples were grown in a different location than were the *jamesii* samples.

TABLE 4-11 – HPLC phenolic results for Bamberg 02.

Accession ID	Species	Group	Caffeic Acid µg/gfw	Chlorogenic Acid µg/gfw	Vanillic Acid µg/gfw	p-coumaric Acid µg/gfw	epicatechin µg/gfw	t-cinnamic Acid µg/gfw	Rutin Hydrate µg/gfw	Gallic Acid µg/gfw	Total Phenolics µg/gfw
184774	FFAO 52	<i>pinnatisectum</i>	high	1570	161						1730
320266	320266.17	<i>commersonii</i>	high	236	1117	11					1360
230489	HERB 4.1-.9	<i>pinnatisectum</i>	high	213	1003	12					1221
275235	HERB 11.1-.9	<i>pinnatisectum</i>	high	174	1019	12					1201
275234	HERB 10.1-.3	<i>pinnatisectum</i>	high	175	986	12					1169
253214	HERB 5.1-.8	<i>pinnatisectum</i>	high	226	911						1137
275233	HERB 9.1-.9	<i>pinnatisectum</i>	high	199	890	10					1093
473243	FFAO 68	<i>tarijense</i>	species	41	1000	9					1030
275231	TAX 31	<i>pinnatisectum</i>	high	145	813						959
184774	HERB1.1-.6	<i>pinnatisectum</i>	high	200	742	11					946
197760	AO 10.3	<i>chacoense</i>	species	49	802						851
275232	TAX 32	<i>pinnatisectum</i>	high	107	722						829
197760	AO 10.7	<i>chacoense</i>	species	46	609						655
275232	HERB 8.1-.8	<i>pinnatisectum</i>	high	151	720	12					639
190115	TAX 30	<i>pinnatisectum</i>	high	124	471	8					598
275230	HERB 6.1-.9	<i>pinnatisectum</i>	high	150	420	12		16			580
283109	FFAO 65	<i>stoloniferum</i>	species	70	470		7		11		558
275262	AO 28.7	<i>jamesii</i>	high	121	602	11					530
186553	HERB 2.1-.9	<i>pinnatisectum</i>	high	183	331	12					518
275231	HERB 7.1-.9	<i>pinnatisectum</i>	high	174	488	8	9				508
275236	TAX 33	<i>pinnatisectum</i>	high	126	372	11					506
218225	AO 34.18	<i>microdontum</i>	species	55	408	8					465
498383	FFAO 37	<i>megistacrolobum</i>	high	100	332	17	8				453
275262	AO 28.13	<i>jamesii</i>	high	207	216		11				430
275262	AO 28.2	<i>jamesii</i>	high	141	280	13					426

TABLE 4-11 – *continued*

Accession	ID	Species	Group	Caffeic	Chlorogenic	Vanillic	p-coumaric	t-cinnamic		Rutin	Gallic	Total
				Acid	Acid	Acid	Acid	epicatechin	Acid	Hydrate	Acid	Phenolics
				µg/gfw	µg/gfw	µg/gfw	µg/gfw	µg/gfw	µg/gfw	µg/gfw	µg/gfw	µg/gfw
341233	TAX 71	<i>cardiophyllum</i>	high	79	964	7	7					405
498383	AO 19.10	<i>megistacrolobum</i>	species	58	180	11						241
275262	AO 28.4	<i>jamesii</i>	high	90	147	12						200
255530	TAX 44	<i>brachistotrichum</i>	low	35							270	170
205510	AO 34.13	<i>stoloniferum</i>	species	46	119							165
498039	FFAO 51	<i>polytrichon</i>	species	45	97		9					148
473190	FFAO 42	<i>oplocense</i>	species	63	39				127			145
341235	TAX 72	<i>cardiophyllum</i>	high	60	88	7		6	13			101
500053	AO 60.7	<i>spgazzinii</i>	species	56	43							99
473481	FFAO-2	<i>acaule</i>	species	53	31					14		98
500049	FFAO 24	<i>gourlayi</i>	species	50	31					9		90
472871	EV 802	<i>infundibuliforme</i>	species	63	63							84
500053	AO 60.14	<i>spgazzinii</i>	species	55	20		9					67
472923	FFAO 31	<i>kurtzianum</i>	species	48								48
595478	TAX 145	<i>sambucinum</i>	species	39	18	6						46
595486	TAX 85	<i>cardiophyllum</i>	species	40		7						41
611104	TAX 198	<i>edinense</i>	low	39								39
545817	TAX 53	<i>brachistotrichum</i>	low	37								37
545813	TAX 50	<i>brachistotrichum</i>	low	34				7				36
545820	TAX 143	<i>nyaritense</i>	low	35								35
545815	TAX 52	<i>brachistotrichum</i>	low	35								35
545827	TAX 144	<i>nyaritense</i>	low	35								35
255528	TAX 42	<i>brachistotrichum</i>	low	34								34
320265	TAX 45	<i>brachistotrichum</i>	species	38		7						22

TABLE 4-12 – HPLC phenolic results for *jamesii* samples.

Accession	Species	Group	Caffeic Acid µg/gfw	Chlorogenic Acid µg/gfw	Vanillic Acid µg/gfw	Total µg/gfw
595784	<i>Jamesii</i>	high	268	88.		356
275262	<i>Jamesii</i>	high	172	105.		277
275172	<i>Jamesii</i>	high	183	68.		250
603056	<i>Jamesii</i>	high	224.		9	233
458424	<i>Jamesii</i>	high	157	65.		223
603055	<i>Jamesii</i>	high	189.	.		189
275266	<i>Jamesii</i>	high	164.	.		164

### ***Broad Screen for Carotenoid Content***

*Standard Curves for Lutein and β-carotene* – Spectrophotometric readings for the ethanol samples at 445 nm were converted into lutein equivalents based on the following equation:  $y = 3028.6x + 8.1063$ , where  $x$  = absorbance at 445nm and  $y$  = µg lutein equivalents/100gfw. The  $R^2$  value for this curve was 0.9991. Hexane samples were analyzed at 450 nm and converted into β-carotene equivalents with the following equation:  $y = 373.59x + 2.0463$ , where  $x$  = absorbance at 450nm, and  $y$  = µg β-carotene equivalents/100gfw. The  $R^2$  value for this equation was 0.9993. The values reported in the subsequent discussion on the broad screen of carotenoids are based on the aforementioned equations.

Due to a freezer malfunction, all *jamesii* samples were lost, and thus were not analyzed for carotenoids.

*Bamberg 1* – A wide range of variation in carotenoid content was observed in the 30 accessions analyzed in Bamberg 1. Micrograms of lutein equivalents ranged from 142-859 µg/100gfw, with an average value of 387, while average values of β-carotene

equivalents ranged from 6-52  $\mu\text{g}/100\text{gfw}$ , with an average value of 21. Total carotenoid content was estimated by adding together the lutein and  $\beta$ -carotene equivalents, and was found to range from 151-893  $\mu\text{g}/100\text{gfw}$ , with an average value of 404. A six-fold difference was observed between the accession with the lowest total carotenoid content and that with the highest (Table 4-13). The average total carotenoid content of the cultivated genotypes analyzed by the same method ranged from 94-536  $\mu\text{g}/100\text{gfw}$  (see chapter III). Since the interest in the wild species was to enhance the levels of carotenoids already contained in cultivated potato, only species that are higher in total carotenoid content are of interest. Only three accessions, PI 458374 (*S. vernei*), PI 310993 (*S. lignicaule*), and PI 607860 (*S. oxycarpum*), met this criterion. Analysis of variance revealed significant differences between genotypes ( $p < .0001$ ), while replications were insignificant ( $p = .5956$ ). When the hexane and ethanol fractions were analyzed separately, significant differences were found between accessions, but not between replications for both fractions. Since it was observed during the DPPH analysis that many of the accessions high in antioxidant activity were quite yellow, a correlation analysis was performed between total carotenoid content and total antioxidant activity. Pearson's correlation coefficient was calculated to be 0.34.

TABLE 4-13 – Carotenoid content of accessions analyzed from Bamberg 1.

Accession	Species	µg Lutein eq/ 100gfw	µg/B-carotene eq/ 100gfw	Total µg carotenoid eq/ 100gfw
PI 458374	<i>vernei</i>	859	34	893
PI 310993	<i>lignicaule</i>	781	28	809
PI 607860	<i>oxycarpum</i>	620	37	672
PI 498314	<i>violaceimarmoratum</i>	559	26	586
PI 604040	<i>alandiae</i>	541	41	583
PI 597721	<i>hoopesii</i>	526	52	579
PI 607866	<i>brachycarpum</i>	464	41	518
PI 558108	<i>oplocense</i>	463	28	491
PNT bulked	<i>pinnatisectum</i>	447	15	462
PI 47310A	<i>medians</i>	417	30	447
PI 597732	<i>megistacrolobum</i>	399	13	412
PI 595507	<i>berthaultii</i>	390	20	409
PI 568929	<i>bukasovii</i>	346	13	359
PI 558404	<i>hougasii</i>	340	16	356
PI 320266	<i>commersonii</i>	337	11	349
PI 597710	<i>oplocense</i>	312	27	339
PI 473086	<i>gourlayi</i>	300	17	318
PI 320316	<i>microdontum</i>	290	15	305
PI 597753	<i>hoopesii</i>	286	13	298
PI 564050	<i>jamesii</i>	278	19	297
PI 283088	<i>laxissimum</i>	242	25	267
PI 564029	<i>fenderli</i>	250	14	263
PI 473-412	<i>commersonii</i>	250	13	263
PI 255545	<i>polytrichon</i>	240	9	249
PI 320342	<i>polyadenium</i>	226	12	237
PI 597767	<i>sparsipilum</i>	221	8	230
PI 545828	<i>nayaritense</i>	152	6	158
PI 545 832	<i>brachistotrichum</i>	142	9	151
PI 597768	<i>sparsipilum</i>	536	.	.

*Bamberg 2* – A wide range of variation in carotenoid content was observed in the 62 accessions analyzed in the Bamberg 2 group. Micrograms of lutein equivalents ranged from 125-699 µg/100gfw, with an average value of 335, while average values of β-carotene equivalents ranged from 4-52 µg/100gfw, with an average value of 15. Total carotenoid content was estimated by adding together the lutein and β-carotene

equivalents, and was found to range from 130-771, with an average value of 351. A six-fold difference was observed between the accession with the lowest total carotenoid content and that with the highest (Table 4-14). Since the interest in the wild species was to enhance the levels of carotenoids already contained in cultivated potato, only species that were higher in total carotenoid content than the highest cultivated varieties (536  $\mu\text{g}/100\text{gfw}$ ) were of interest. Eight accessions met this criterion. They included PI 498232 (*S. demissum*), PI 184774 (*S. pinnatisectum*), PI 498383 (*S. megistacrolobum*), PI 275236 (*S. pinnatisectum*), PI 347766 (*S. pinnatisectum*), PI 498351 (*S. infundibuliforme*), PI 218225 (*S. microdontum*), and PI 473244 (*S. tarijense*). Analysis of variance revealed significant differences between genotypes ( $p < .0001$ ), while no significant differences were found between replications ( $p = .6394$ ) or replications from different areas of the field ( $p = .9892$ ). When the hexane fraction was analyzed separately, significant differences were found between accessions ( $p < .0001$ ) and field replications ( $p = .0030$ ), but not between replications ( $p = .0604$ ). Similar to the results for Bamberg 1, the ethanol fractions had significant differences between accessions ( $p < .0001$ ), but not field replications ( $p = 0.4517$ ) or replications ( $p = .6262$ ). Since it was observed during the DPPH analysis that many of the accessions high in antioxidant activity were quite yellow, a correlation analysis was performed between total carotenoid content and total antioxidant activity. Pearson's correlation coefficient was calculated to be 0.48.



TABLE 4-14 - Carotenoid content of accessions analyzed from Bamberg 2.

accession number	Species	µg Lutein eq/ 100gfw	µg B-carotene eq /100gfw carotenod/100gfw	µg total
498232	<i>demissum</i>	516	18	771
184774	<i>pinnatisectum</i>	650	9	634
498383	<i>megistacrolobum</i>	603	8	611
275236	<i>pinnatisectum</i>	596	12	609
347766	<i>pinnatisectum</i>	571	15	586
498351	<i>infundibuliforme</i>	583	13	586
218225	<i>microdontum</i>	555	10	565
473244	<i>tarijense</i>	523	40	538
205510	<i>stoloniferum</i>	699	7	531
283109	<i>stoloniferum</i>	377	52	528
472941	<i>kurtzianum</i>	500	13	515
500053	<i>spgazzinii</i>	478	8	486
473345	<i>canasense</i>	452	11	462
275187	<i>bulbocastanum</i>	399	48	447
275262	<i>jamesii</i>	423	19	441
545751	<i>bulbocastanum</i>	421	18	438
320293	<i>chacoense</i>	415	22	437
472661	<i>acaule</i>	419	12	431
243503	<i>commersonii</i>	408	22	430
265863	<i>canasense</i>	396	16	412
473171	<i>microdontum</i>	382	9	391
500041	<i>microdontum</i>	369	8	377
500047	<i>acaule</i>	366	9	375
497998	<i>fendleri</i>	338	29	367
498039	<i>polytrichon</i>	355	5	360
435079	<i>oplocense</i>	317	9	355
205407	<i>spgazzinii</i>	336	4	340
473062	<i>gourlayi</i>	329	9	338
310956	<i>canasense</i>	303	19	323
473133	<i>megistacrolobum</i>	311	11	322
265579	<i>gourlayi</i>	309	7	316
472923	<i>kurtzianum</i>	288	20	308
498057	<i>stoloniferum</i>	292	7	297
195190	<i>jamesii</i>	264	29	293
195204	<i>stenotomum</i>	279	10	289
473185	<i>oplocense</i>	317	17	289
472894	<i>infundibuliforme</i>	326	18	283
195206	<i>tarijense</i>	274	8	282
243513	<i>bulbocastanum</i>	258	21	280
473243	<i>tarijense</i>	262	15	277
161173	<i>verrucosum</i>	267	4	271
545725	<i>papita</i>	260	6	266

TABLE 4-14 - *continued*

accession number	species	µg Lutein eq/ 100gfw	µg B-carotene eq /100gfw	µg total carotenod/100gfw
275139	<i>chacoense</i>	238	19	257
160208	<i>demissum</i>	236	20	256
472842	<i>commersonii</i>	240	15	256
230589	<i>demissum</i>	236	20	256
473336	<i>tarijense</i>	255	6	246
458425	<i>jamesii</i>	210	26	236
265867	<i>infundibuliforme</i>	204	23	226
265873	<i>megistacrolobum</i>	169	8	221
473411	<i>commersonii</i>	199	20	220
472986	<i>spgazzinii</i>	209	6	214
255547	<i>polytrichon</i>	203	5	208
473481	<i>acaule</i>	192	10	203
275156	<i>fendleri</i>	191	11	202
184770	<i>polytrichon</i>	183	6	189
500049	<i>gourlayi</i>	166	12	178
473190	<i>oplocense</i>	157	12	169
498033	<i>papita</i>	144	7	150
498004	<i>fendleri</i>	137	11	148
249929	<i>papita</i>	125	5	130
498359	<i>kurtzianum</i>	277	17	294

*Bamberg 02* – A wide range of variation in carotenoid content was observed in the 243 accessions analyzed in the Bamberg 02 group. Micrograms of lutein equivalents ranged from 74-875 µg/100gfw, with an average value of 231, while average values of β-carotene equivalents ranged from 0-111 µg/100gfw, with an average value of 12. Total carotenoid content was estimated by adding together the lutein and β-carotene equivalents, and was found to range from 84-888 µg/100gfw, with an average value of 246. An 11-fold difference was observed between the genotype with the lowest total carotenoid content and that with the highest (Table 4-15). Since the interest in wild species was to enhance the levels of carotenoids already contained in cultivated potato, only species that were higher in total carotenoid content were of interest. Fifteen accessions matched this criterion and are listed in gray in Table 4-15. Analysis of variance for total carotenoid content revealed significant differences between accessions

( $p < .0001$ ), while replications were found to be insignificant ( $p = .1980$ ). When the hexane fraction was analyzed separately, significant differences were found between accessions ( $p < .0001$ ) and replications ( $p < .0001$ ). Ethanol fractions had significant differences between accessions ( $p < .0001$ ), but not replications ( $p = 0.0375$ ). Since it was observed during the DPPH analysis that many of the accessions high in antioxidant activity were quite yellow, a correlation analysis was performed between total carotenoid content and total antioxidant activity. Pearson's correlation coefficient was calculated to be 0.54.

TABLE 4-15 - Carotenoid content of accessions analyzed from Bamberg 02.

Accession	ID	Species	$\mu\text{g lutein eq/}$ <b>100gfw</b>	$\mu\text{g b-carotene eq/}$ <b>100gfw</b>	$\mu\text{g carotenoids/}$ <b>100gfw</b>
275231	TAX 31	<i>pinnatisectum</i>	875	13	888
275232	HERB 8.1-.8	<i>pinnatisectum</i>	717	9	726
320266	320266.16	<i>commersonii</i>	669	6	675
498383	AO 39.10	<i>megistacrolobum</i>	665	8	673
275232	TAX 32	<i>pinnatisectum</i>	652	11	663
186553	HERB 2.1-.9	<i>pinnatisectum</i>	605	12	618
347766	HERB 13.1-.9	<i>pinnatisectum</i>	600	10	610
320293	FFAO 12	<i>chacoense</i>	581	15	597
253214	HERB 5.1-.8	<i>pinnatisectum</i>	580	16	596
283109	FFAO 65	<i>stoloniferum</i>	544	41	585
190115	HERB 3.1-.7	<i>pinnatisectum</i>	569	14	583
275230	HERB 6.1-.9	<i>pinnatisectum</i>	564	18	582
275235	HERB 11.1-.9	<i>pinnatisectum</i>	557	10	567
275233	HERB 9.1-.9	<i>pinnatisectum</i>	524	20	544
537023	HERB 14.1-.7	<i>pinnatisectum</i>	523	15	538
197760	AO 10.7	<i>chacoense</i>	512	20	532
184774	HERB1.1-.6	<i>pinnatisectum</i>	507	17	524
472909	EV 836	<i>infundibuliforme</i>	508	11	519
275231	HERB 7.1-.9	<i>pinnatisectum</i>	505	12	517
275234	HERB 10.1-.3	<i>pinnatisectum</i>	498	11	509
320266	320266.17	<i>commersonii</i>	498	9	507
230489	HERB 4.1-.9	<i>pinnatisectum</i>	484	15	499
341231	TAX 70	<i>cardiophyllum</i>	488	7	495
275236	HERB 12.1-.9	<i>pinnatisectum</i>	482	11	493
275236	TAX 33	<i>pinnatisectum</i>	479	5	484

TABLE 4-15 - *continued*

Accession	ID	Species	µg lutein eq/ 100gfw	µg b-carotene eq/ 100gfw	µg carotenoids/ 100gfw
197760	AO 10.3	<i>chacoense</i>	460	21	481
545751	FFAO 6	<i>bulbocastanum</i>	418	8	425
197760	AO 10.10	<i>chacoense</i>	368	19	387
205510	FFAO 64	<i>stoloniferum</i>	373	6	379
218225	AO 34.2	<i>microdontum</i>	371	4	375
197760	AO 10.8	<i>chacoense</i>	344	13	357
341233	TAX 71	<i>cardiophyllum</i>	344	12	356
472888	EV 818	<i>infundibuliforme</i>	339	16	355
472941	FFAO 32	<i>kurtzianum</i>	341	13	354
197760	AO 10.5	<i>chacoense</i>	343	10	353
498351	EV 868	<i>infundibuliforme</i>	334	14	347
472886	EV 816	<i>infundibuliforme</i>	328	16	344
498383	AO 39.5	<i>megistacrolobum</i>	331	13	343
472846	EV 691	<i>commersonii</i>	335	7	342
472876	EV 806	<i>infundibuliforme</i>	319	22	340
218225	AO 34.5	<i>microdontum</i>	316	8	324
197760	AO 10.9	<i>chacoense</i>	307	16	323
218225	AO 34.14	<i>microdontum</i>	313	10	323
197760	AO 10.14	<i>chacoense</i>	313	6	319
320266	320266.1	<i>commersonii</i>	303	15	318
218225	AO 34.7	<i>microdontum</i>	301	11	312
498354	EV 870	<i>infundibuliforme</i>	300	11	311
218225	FFAO 34	<i>microdontum</i>	296	15	310
197760	AO 10.11	<i>chacoense</i>	297	13	310
498039	FFAO 51	<i>polytrichon</i>	277	27	305
197760	AO 10.4	<i>chacoense</i>	287	12	300
472896	EV 824	<i>infundibuliforme</i>	290	9	298
414147	EV 774	<i>infundibuliforme</i>	266	30	295
320266	F2 4.11	<i>commersonii</i>	287	7	295
218225	AO 34.18	<i>microdontum</i>	285	8	292
472884	EV 814	<i>infundibuliforme</i>	262	22	285
472898	EV 826	<i>infundibuliforme</i>	274	6	281
197760	AO 10.6	<i>chacoense</i>	268	12	279
243510	FFAO 4	<i>bulbocastanum</i>	268	8	277
498345	EV 862	<i>infundibuliforme</i>	267	8	275
190115	TAX 30	<i>pinnatisectum</i>	263	11	275
320295	EV 772	<i>infundibuliforme</i>	251	22	274
320266	F2 5.7	<i>commersonii</i>	259	10	269
590921	EV 695	<i>commersonii</i>	255	11	266
458322	EV 782	<i>infundibuliforme</i>	237	29	266
435076	EV 776	<i>infundibuliforme</i>	245	19	264
442676	EV 778	<i>infundibuliforme</i>	233	31	264
218225	AO 34.3	<i>microdontum</i>	258	5	263
218225	AO 34.13	<i>microdontum</i>	248	14	261
218225	AO 34.12	<i>microdontum</i>	250	9	258

TABLE 4-15 - *continued*

Accession	ID	Species	µg lutein eq/ 100gfw	µg b-carotene eq/ 100gfw	µg carotenoids/ 100gfw
197760	AO 10.12	<i>chacoense</i>	244	13	257
472869	EV 800	<i>infundibuliforme</i>	242	15	256
275139	FFAO 11	<i>chacoense</i>	242	14	256
472892	EV 820	<i>infundibuliforme</i>	245	10	256
500046	EV 873	<i>infundibuliforme</i>	248	7	255
498343	EV 860	<i>infundibuliforme</i>	242	12	254
472856	EV 787	<i>infundibuliforme</i>	239	15	254
500049	FFAO 24	<i>gourlayi</i>	142	111	252
458325	EV 785	<i>infundibuliforme</i>	233	17	250
500053	AO 60.13	<i>spgazzinii</i>	239	8	247
275262	AO 28.2	<i>jamesii</i>	239	7	246
218225	AO 34.15	<i>microdontum</i>	233	13	246
472880	EV 810	<i>infundibuliforme</i>	189	56	245
566767	EV 881	<i>infundibuliforme</i>	223	21	244
255527	TAX 41	<i>brachistotrichum</i>	238	4	242
498383	AO 39.9	<i>megistacrolobum</i>	230	9	239
545827	TAX 144	<i>nyaritense</i>	223	16	239
275262	AO 28.3	<i>jamesii</i>	234	4	238
218225	AO 34.16	<i>microdontum</i>	225	11	236
473414	EV 844	<i>infundibuliforme</i>	228	7	235
275262	AO 28.4	<i>jamesii</i>	225	9	234
500053	AO 60.18	<i>spgazzinii</i>	221	13	234
218225	AO 34.10	<i>microdontum</i>	225	7	232
545824	TAX 76	<i>cardiophyllum</i>	223	7	230
265863	FFAO 7,8,9	<i>canasense</i>	203	25	228
320266	F2 5.1	<i>commersonii</i>	215	13	228
472917	EV 842	<i>infundibuliforme</i>	216	11	227
472913	EV 838	<i>infundibuliforme</i>	212	15	227
197760	AO 10.15	<i>chacoense</i>	216	10	227
472894	EV 822	<i>infundibuliforme</i>	216	10	226
498333	EV 850	<i>infundibuliforme</i>	215	10	225
275262	AO 28.16	<i>jamesii</i>	220	4	224
595467	TAX 78	<i>cardiophyllum</i>	208	16	224
472882	EV 812	<i>infundibuliforme</i>	196	28	224
197760	AO 10.17	<i>chacoense</i>	213	10	223
472901	EV 828	<i>infundibuliforme</i>	209	14	223
472862	EV 793	<i>infundibuliforme</i>	212	10	222
498341	EV 858	<i>infundibuliforme</i>	207	13	220
498383	AO 39.12	<i>megistacrolobum</i>	208	11	218
275216	TAX 66	<i>cardiophyllum</i>	209	9	218
320266	F2 6.17	<i>commersonii</i>	213	4	218
472923	FFAO 31	<i>kurtzianum</i>	209	9	218
197760	AO 10.16	<i>chacoense</i>	206	11	217
197760	AO 10.13	<i>chacoense</i>	209	8	217
275184	TAX 6	<i>bulbocastanum</i>	202	13	215

TABLE 4-15 - *continued*

Accession	ID	Species	µg lutein eq/ 100gfw	µg b-carotene eq/ 100gfw	µg carotenoids/ 100gfw
283062	TAX 68	<i>cardiophyllum</i>	207	9	215
500053	AO 60.7	<i>spgazzinii</i>	210	5	215
472915	EV 840	<i>infundibuliforme</i>	207	8	214
472860	EV 791	<i>infundibuliforme</i>	197	16	213
500053	AO 60.17	<i>spgazzinii</i>	203	10	213
498383	AO 39.18	<i>megistacrolobum</i>	202	8	210
320266	320266.2	<i>commersonii</i>	199	9	208
275262	AO 28.13	<i>jamesii</i>	199	8	207
473522	EV 846	<i>infundibuliforme</i>	199	7	206
218225	AO 34.8	<i>microdontum</i>	197	9	206
498383	AO 39.6	<i>megistacrolobum</i>	200	5	206
275262	AO 28.1	<i>jamesii</i>	201	5	206
320266	F2 4.4	<i>commersonii</i>	196	6	202
498383	AO 39.14	<i>megistacrolobum</i>	195	7	202
472871	EV 802	<i>infundibuliforme</i>	179	23	202
498383	AO 39.1	<i>megistacrolobum</i>	197	4	201
472873	EV 804	<i>infundibuliforme</i>	191	10	201
218225	AO 34.6	<i>microdontum</i>	177	23	199
472903	EV 830	<i>infundibuliforme</i>	188	9	197
275262	AO 28.8	<i>jamesii</i>	189	7	195
218225	AO 34.17	<i>microdontum</i>	178	15	193
500053	AO 60.4	<i>spgazzinii</i>	189	3	193
545752	TAX 12	<i>bulbocastanum</i>	185	7	192
320266	F2 4.7	<i>commersonii</i>	183	8	191
320266	320266.5	<i>commersonii</i>	177	14	191
595478	TAX 145	<i>sambucinum</i>	181	10	190
320266	F2 4.2	<i>commersonii</i>	180	9	189
473481	FFAO-2	<i>acaule</i>	163	26	189
320266	F2 4.6	<i>commersonii</i>	177	12	189
275262	AO 28.15	<i>jamesii</i>	182	5	187
458425	FFAO 29	<i>jamesii</i>	150	37	187
320266	F2 5.6	<i>commersonii</i>	181	6	186
500053	AO 60.14	<i>spgazzinii</i>	176	10	186
218225	AO 34.4	<i>microdontum</i>	181	5	185
595476	TAX 80	<i>cardiophyllum</i>	161	24	185
320266	F2 5.5	<i>commersonii</i>	179	6	185
500053	AO 60.12	<i>spgazzinii</i>	174	11	185
218225	AO 34.9	<i>microdontum</i>	172	11	183
498217	TAX 48	<i>brachistotrichum</i>	177	6	183
275262	AO 28.6	<i>jamesii</i>	177	6	183
566769	EV 883	<i>infundibuliforme</i>	164	18	182
498383	AO 39.2	<i>megistacrolobum</i>	153	27	180
500053	AO 60.16	<i>spgazzinii</i>	171	7	178
498383	AO 39.7	<i>megistacrolobum</i>	171	7	178
320266	F2 5.2	<i>commersonii</i>	172	6	178
595482	TAX 84	<i>cardiophyllum</i>	171	5	177

TABLE 4-15 - *continued*

Accession	ID	Species	µg lutein eq/ 100gfw	µg b-carotene eq/ 100gfw	µg carotenoids/ 100gfw
275262	AO 28.12	<i>jamesii</i>	170	6	176
605371	TAX 141	<i>jamesii</i>	167	8	176
186548	TAX 59	<i>cardiophyllum</i>	167	7	175
320266	F2 5.11	<i>commersonii</i>	169	6	175
320266	F2 4.3	<i>commersonii</i>	168	6	174
500053	AO 60.3	<i>spgazzinii</i>	164	10	174
320266	F2 5.9	<i>commersonii</i>	169	4	173
320266	F2 5.12	<i>commersonii</i>	162	11	173
275262	AO 28.5	<i>jamesii</i>	166	6	172
320266	F2 4.17	<i>commersonii</i>	160	11	171
558483	TAX 150	<i>verrucosum</i>	163	8	171
545894	EV 875	<i>infundibuliforme</i>	157	13	170
275262	AO 28.7	<i>jamesii</i>	163	6	169
597678	TAX 88	<i>cardiophyllum</i>	151	16	167
320266	F2 6.1	<i>commersonii</i>	157	10	167
320266	F2 4.12	<i>commersonii</i>	157	9	166
498383	AO 39.3	<i>megistacrolobum</i>	159	7	166
320266	F2 5.4	<i>commersonii</i>	156	10	165
500053	AO 60.8	<i>spgazzinii</i>	158	7	165
341235	TAX 72	<i>cardiophyllum</i>	154	10	164
498383	AO 39.13	<i>megistacrolobum</i>	158	6	164
498383	AO 39.4	<i>megistacrolobum</i>	154	8	162
320266	F2 4.13	<i>commersonii</i>	152	10	162
197760	FFAO 10	<i>chacoense</i>	150	10	161
500053	AO 60.2	<i>spgazzinii</i>	150	10	161
611104	TAX 198	<i>edinense</i>	147	13	160
320266	F2 4.15	<i>commersonii</i>	152	8	160
320266	320266.7	<i>commersonii</i>	152	6	158
498339	EV 856	<i>infundibuliforme</i>	148	10	157
275262	AO 28.9	<i>jamesii</i>	150	6	156
251720	TAX 40	<i>brachistotrichum</i>	150	4	154
500053	AO 60.9	<i>spgazzinii</i>	144	9	153
472907	EV 834	<i>infundibuliforme</i>	144	8	153
320266	F2 4.5	<i>commersonii</i>	144	8	152
498335	EV 852	<i>infundibuliforme</i>	139	12	152
592422	FFAO 30	<i>jamesii</i>	135	16	151
500053	AO 60.15	<i>spgazzinii</i>	143	7	151
320266	F2 5.8	<i>commersonii</i>	134	16	150
545813	TAX 50	<i>brachistotrichum</i>	143	7	150
498337	EV 854	<i>infundibuliforme</i>	132	18	150
275262	AO 28.14	<i>jamesii</i>	143	6	148
275262	AO 28.11	<i>jamesii</i>	142	6	148
500053	AO 60.10	<i>spgazzinii</i>	128	17	145
498383	AO 39.11	<i>megistacrolobum</i>	140	5	145
255519	TAX 60	<i>cardiophyllum</i>	128	17	145
472878	EV 808	<i>infundibuliforme</i>	135	10	145

TABLE 4-15 - *continued*

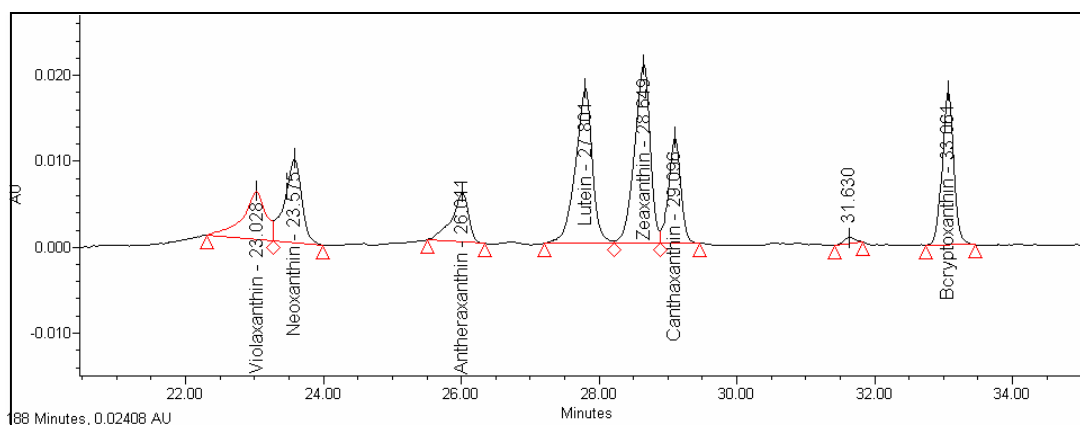
Accession	ID	Species	µg lutein eq/ 100gfw	µg b-carotene eq/ 100gfw	µg carotenoids/ 100gfw
320266	F2 4.14	<i>commersonii</i>	134	9	143
275262	AO 28.10	<i>jamesii</i>	138	5	143
545817	TAX 53	<i>brachistotrichum</i>	137	6	143
320266	F2 6.2	<i>commersonii</i>	131	11	142
283063	TAX 69	<i>cardiophyllum</i>	131	9	140
184762	TAX 57	<i>cardiophyllum</i>	125	5	130
500053	AO 60.11	<i>spgazzinii</i>	115	13	128
255530	TAX 44	<i>brachistotrichum</i>	114	13	127
320265	TAX 45	<i>brachistotrichum</i>	121	5	126
320266	F2 6.16	<i>commersonii</i>	119	6	125
500053	AO 60.6	<i>spgazzinii</i>	115	10	125
498383	AO 39.8	<i>megistacrolobum</i>	118	7	125
545812	TAX 49	<i>brachistotrichum</i>	118	5	123
320266	F2 4.18	<i>commersonii</i>	112	9	121
545820	TAX 143	<i>nyaritense</i>	109	10	119
595489	TAX 87	<i>cardiophyllum</i>	111	8	119
497993	TAX 46	<i>brachistotrichum</i>	111	4	115
558401	TAX 55	<i>brachistotrichum</i>	108	7	114
545832	TAX 54	<i>brachistotrichum</i>	106	6	112
595486	TAX 85	<i>cardiophyllum</i>	102	7	109
558460	TAX 56	<i>brachistotrichum</i>	91	18	108
255528	TAX 42	<i>brachistotrichum</i>	94	14	108
595480	TAX 83	<i>cardiophyllum</i>	101	7	108
545753	TAX 74	<i>cardiophyllum</i>	90	17	107
275187	FFAO 5	<i>bulbocastanum</i>	93	12	105
320266	F2 6.11	<i>commersonii</i>	92	9	101
545815	TAX 52	<i>brachistotrichum</i>	94	6	100
184771	TAX 58	<i>cardiophyllum</i>	88	6	94
347759	TAX 73	<i>cardiophyllum</i>	74	20	94
255529	TAX 43	<i>brachistotrichum</i>	85	9	94
558379	TAX 13	<i>bulbocastanum</i>	87	4	91
595488	TAX 86	<i>cardiophyllum</i>	85	5	90
275212	TAX 62	<i>cardiophyllum</i>	80	8	88
612456	TAX 142	<i>jamesii</i>	80	7	87
558460	TAX 56B	<i>brachistotrichum</i>	79	5	84
500053	AO 60.5	<i>spgazzinii</i>	78	6	84

### ***HPLC Analysis of Carotenoid Compounds***

Based on results of the spectrophotometric broad screen, the top 10% of accessions in total carotenoid content were analyzed via HPLC. Standards included in the carotenoid analysis were violaxanthin, neoxanthin, antheraxanthin, lutein, zeaxanthin,



canthaxanthin  $\beta$ -cryptoxanthin, and  $\beta$ -carotene. An HPLC chromatogram of the seven compounds analyzed is shown in Figure 4-4.  $\beta$ -carotene eluted much later than these seven compounds, and separation was not a problem.



**FIGURE 4-4.**  
**Chromatogram showing the separation of carotenoid components via HPLC.**

*Bamberg 1* – The genotypes analyzed from Bamberg 1 included the top 10% of accessions from the spectrophotometric broad screen, as well as the bottom two accessions. To reduce the possibility of overlooking an accession that could contribute to the level of one particular compound when used as parents, a survey of nine additional accessions from different species were analyzed via HPLC (Table 4-16).

TABLE 4-16 – HPLC carotenoid results for Bamberg 1.

Accession	Species	Group	$\mu\text{g lutein}/100\text{gfw}$
458374	<i>vernei</i>	high	14.1
310993	<i>lignicaule</i>	high	9.35
607860	<i>oxycarpum</i>	high	18.75
498314	<i>violaceimarmoratum</i>	high	
545832	<i>brachistortrichum</i>	low	
545828	<i>nayaritense</i>	low	
604040	<i>alandiae</i>	species	13.25
607866	<i>brachycarpum</i>	species	15.7
568929	<i>bukasovii</i>	species	
558404	<i>hougasii</i>	species	
320342	<i>polyadenium</i>	species	
597767	<i>sparsipilum</i>	species	
184774	<i>pinnatisectum</i>	species	
320266	<i>commersonii</i>	species	

Lutein was the only carotenoid identified in the samples that matched both retention time and spectra. Lutein concentration ranged from 0-18.75  $\mu\text{g}/100\text{gfw}$ . Had the decision been made to quantitate based solely on retention time, the results would have been considerably different. Peaks were identified which matched retention time for violaxanthin, neoxanthin, lutein, and zeaxanthin (Table 4-17). PI 607860 (*S. oxycarpum*) contained the highest level of lutein found in Bamberg 1. A representative chromatogram is pictured in Figure 4-5.

TABLE 4-17 – HPLC carotenoid results for Bamberg 1 based on retention time only.

Accession	Species	group	µg Lutein/ 100gfw	µg violaxanthin/ 100gfw	µg neoxanthin/ 100gfw	µg zeaxanthin/ 100gfw
458374	<i>vernei</i>	high	14.1	9.5	6.95	
310993	<i>lignicaule</i>	high	9.35			
607860	<i>oxycarpum</i>	high	18.75	10.15	9.1	6.66
498314	<i>violaceimarmoratum</i>	high			5.55	
545832	<i>brachistortrichum</i>	low		8.45		
545828	<i>nayaritense</i>	low				
604040	<i>alandiae</i>	species	13.25	12.1	9.8	
607866	<i>brachycarpum</i>	species	15.7	10.45	7.9	
568929	<i>bukasovii</i>	species	7.75			
558404	<i>hougasii</i>	species	8.7	8.4	5.6	
320342	<i>polyadenium</i>	species				
597767	<i>sparsipilum</i>	species				
184774	<i>pinnatisectum</i>	species				
320266	<i>commersonii</i>	species				

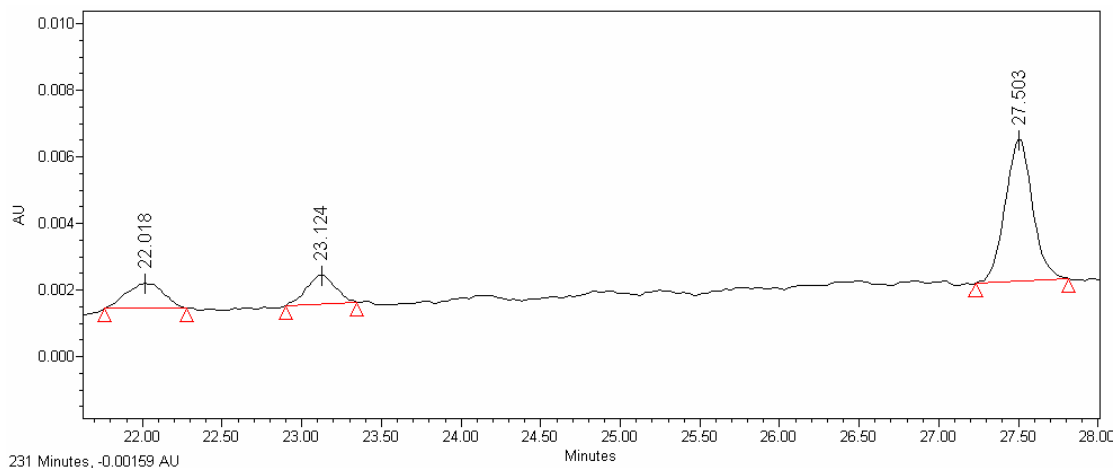


FIGURE 4-5.

A representative HPLC chromatogram of carotenoid samples run from Bamberg 1 (PI 458374).

*Bamberg 2* - The genotypes analyzed from Bamberg 2 included the top 10% of accessions from the spectrophotometric broad screen, as well as the bottom four accessions. To reduce the possibility of overlooking an accession that could contribute to

the level of one particular compound when used as parents, a survey of 15 additional accessions from different species was conducted via HPLC (Table 4-18). Results from Bamberg 2 were disappointing, with no carotenoids matching both retention time and spectra from the standard library. Based solely on retention time, only three accessions had any carotenoids identified. These included PI 472941 (7.65  $\mu\text{g}$  lutein/100gfw), PI 320293 (8.6  $\mu\text{g}$  lutein/100gfw), and PI 497998 (8.35  $\mu\text{g}$  lutein/100gfw and 8.9  $\mu\text{g}$  violaxanthin/100gfw). Since none of the accessions contained yellow flesh, they were not expected to contain high levels of carotenoids; however, they were expected to contain at least small quantities. Since carotenoids can degrade during storage, and a considerable amount of time passed before these were analyzed on the HPLC, this is one possible explanation. However, the Bamberg 1 samples were stored much longer than the Bamberg 2 samples, yet carotenoids were still identified in these.

TABLE 4-18 – *Accessions analyzed by HPLC for carotenoid content from Bamberg 2.*

<b>Accession</b>	<b>Species</b>	<b>Group</b>	<b>Accession</b>	<b>Species</b>	<b>Group</b>
498232	<i>demissum</i>	high	500053	<i>spgazzinii</i>	species
184774	<i>pinnatisectum</i>	high	275187	<i>bulbocastanum</i>	species
498383	<i>megistacrolobum</i>	high	275262	<i>jamesii</i>	species
275236	<i>pinnatisectum</i>	high	320293	<i>chacosense</i>	species
347766	<i>pinnatisectum</i>	high	472661	<i>acaule</i>	species
498351	<i>infundibuliforme</i>	high	497998	<i>fendleri</i>	species
218225	<i>microdontum</i>	high	498039	<i>polytrichon</i>	species
473190	<i>ooplocense</i>	low	435079	<i>ooplocense</i>	species
498033	<i>papita</i>	low	473062	<i>gourlayi</i>	species
498004	<i>fendleri</i>	low	195204	<i>stenotomum</i>	species
249929	<i>papita</i>	low	195206	<i>tarijense</i>	species
205510	<i>stoloniferum</i>	species	161173	<i>verrucosum</i>	species
472941	<i>kurtzianum</i>	species	545725	<i>papita</i>	species

*Bamberg 02* - The genotypes analyzed from Bamberg 02 included the top 10% of accessions from the spectrophotometric broad screen, as well as the bottom six accessions. To reduce the possibility of overlooking an accession that could contribute to the level of one particular compound when used as parents, ten additional accessions from different species were analyzed via HPLC (Table 4-19). As in the Bamberg 2 samples, no spectra matched both retention time and spectra of the standards. Had the decision been made to quantitate based solely on retention time, the results would have been considerably different. Peaks were identified which matched retention times for violaxanthin, neoxanthin, lutein, and zeaxanthin and canthaxanthin (Table 4-20).

TABLE 4-19 - Accessions analyzed by HPLC for carotenoid content from Bamberg 02.

Accession ID	Species	Group	Accession ID	Species	Group		
275231	TAX 31	<i>pinnatisectum</i>	high	275230	HERB 7.1-.9 <i>pinnatisectum</i>	high	
275234	HERB 11.1-.9	<i>pinnatisectum</i>	high	537023	FFAO-2	<i>pinnatisectum</i>	high
458425	FFAO 30	<i>jamesii</i>	high	275236	TAX 33	<i>pinnatisectum</i>	high
184774	HERB 2.1-.9	<i>pinnatisectum</i>	high	197760	AO 10.3	<i>chacoense</i>	high
498383	AO 39.10	<i>megistacrolobum</i>	high	197760	FFAO 11	<i>chacoense</i>	high
275232	TAX 32	<i>pinnatisectum</i>	high	558379	TAX 13	<i>bulbocastanum</i>	low
230489	HERB 5.1-.8	<i>pinnatisectum</i>	high	255529	TAX 43	<i>brachistotrichum</i>	low
473481	FFAO 4	<i>acaule</i>	high	545824	TAX 78	<i>cardiophyllum</i>	low
275231	HERB 8.1-.8	<i>pinnatisectum</i>	high	545827	TAX 145	<i>nyaritense</i>	low
253214	HERB 6.1-.9	<i>pinnatisectum</i>	high	500053	AO 60.5	<i>spgazzinii</i>	low
275232	HERB 9.1-.9	<i>pinnatisectum</i>	high	186548	TAX 60	<i>cardiophyllum</i>	low
347766	HERB 14.1-.7	<i>pinnatisectum</i>	high	195206	FFAO 68	<i>tarijense</i>	species
243510	FFAO 5	<i>bulbocastanum</i>	high	218225	AO 34.2	<i>microdontum</i>	species
275235	HERB 12.1-.9	<i>pinnatisectum</i>	high	472846	EV 691	<i>commersonii</i>	species
197760	AO 10.7	<i>chacoense</i>	high	500053	AO 60.13	<i>spgazzinii</i>	species
190115	HERB 4.1-.9	<i>pinnatisectum</i>	high	558483	TAX 198	<i>verrucosum</i>	species
472909	EV 836	<i>infundibuliforme</i>	high	545820	TAX 144	<i>nyaritense</i>	species
186553	HERB 3.1-.7	<i>pinnatisectum</i>	high	472923	FFAO 32	<i>kurtzianum</i>	species
275233	HERB 10.1-.3	<i>pinnatisectum</i>	high	558460	TAX 56B	<i>brachistotrichum</i>	species
	TAX140		high	595478	TAX 150	<i>sambucinum</i>	species
190115	TAX 30	<i>pinnatisectum</i>	high	265863	FFAO 10	<i>canasense</i>	species
341235	TAX 73	<i>cardiophyllum</i>	high				

TABLE 4-20 - HPLC carotenoid results for Bamberg 02 based on retention time only.

Accession ID	Species	Group	$\mu\text{g}/100\text{gfw}$					
			Lutein	neoxanthin	zeaxanthin	canthaxanthin	violaxanthin	
275231	TAX 31	<i>pinnatisectum</i>	high		6.4	6.05	3.4	
275234	HERB 11.1-.9	<i>pinnatisectum</i>	high					8.4
275232	TAX 32	<i>pinnatisectum</i>	high			6.75	3	
230489	HERB 5.1-.8	<i>pinnatisectum</i>	high		6.2	5.05		
473481	FFAO 4	<i>acaule</i>	high		4.9	4.9		
253214	HERB 6.1-.9	<i>pinnatisectum</i>	high	8.15				
197760	AO 10.7	<i>chacoense</i>	high		7.5	17.7	2.6	9.35
190115	HERB 4.1-.9	<i>pinnatisectum</i>	high		6.2	5.15		
472909	EV 836	<i>infundibuliforme</i>	high		6.6	12.95	3.9	
186553	HERB 3.1-.7	<i>pinnatisectum</i>	high	8.2	4.75			
275233	HERB 10.1-.3	<i>pinnatisectum</i>	high		5.55	5.4	2.65	
190115	TAX 30	<i>pinnatisectum</i>	high	9				
341235	TAX 73	<i>cardiophyllum</i>	high			5.35	3.25	
275236	TAX 33	<i>pinnatisectum</i>	high		5.5	4.9	3	
197760	AO 10.3	<i>chacoense</i>	high		5.65	16.45	3.65	8.45
197760	FFAO 11	<i>chacoense</i>	high			6.05	2.95	
558460	TAX 56B	<i>brachistotrichum</i> species			6.4			8.9

It has been previously reported that during storage, the amount of carotenoid esters remains stable in comparison to the amount of free carotenoids (Tevini *et al.* 1986). The absence of spectral matches in the HPLC analysis could be due to esterification of free carotenoids. Such an event could cause a change in spectra, with no resulting shift in retention time. This is supported by the fact that the spectra, while not identical, are very similar to the standard spectra, indicating that at least part of the compound structure is maintained. Furthermore, carotenoid epoxide standards were not available, but are known to exist in potato. Many of the unexplained peaks could be due to these carotenoid epoxides.

Since there is no published data pertaining to carotenoid content in wild *Solanum* species, the standards were selected based on reports of cultivated potato. The fact that none of the tubers analyzed contained yellow flesh indicated that there would not be

extremely high levels of carotenoids contained in these wild species; however, since the cultivated potato originates from these species, and some cultivated potatoes are known to contain carotenoids, at least modest amounts of these compounds were expected to be revealed in the related *Solanum* species. In a study conducted simultaneously on cultivated genotypes of *S. tuberosum*, very few spectral and retention time matches were discovered. Antheraxanthin concentrations ranging from 14-19  $\mu\text{g}/100\text{gfw}$ , neoxanthin concentrations of 5  $\mu\text{g}/100\text{gfw}$ , and lutein concentrations of 809  $\mu\text{g}/100\text{gfw}$  were reported. The levels of lutein in the wild species, even based on retention time alone, do not appear to be significantly higher than those found in cultivated potato. This, combined with reports that yellow-flesh intensity is highly correlated with carotenoid content, indicates that the wild species analyzed, when bred with cultivated varieties, would not increase carotenoid content in the progeny.

Phenolics, however, were significantly higher in many accessions than in cultivated varieties. In particular, *S. pinnatisectum* and *S. jamesii* accessions consistently ranked among the highest in antioxidant activity and phenolic content. In cultivated genotypes analyzed at the same time as the wild accessions, antioxidant activity ranged from 104-648  $\mu\text{g trolox equivalents/gfw}$ , while the wild accessions ranged in activity from 43-884  $\mu\text{g trolox equivalents/gfw}$ . Since the Bamberg 1 and Bamberg 2 analysis was a broad screen and based on segregating populations, recommendations for future breeding efforts are based on the Bamberg 02 samples. Forty clones derived from tuber seed were higher in antioxidant activity than the highest of the cultivated genotypes. Over half of the accessions analyzed for phenolic content by HPLC were higher in individual compounds than were their cultivated counterparts. In addition, more

compounds were identified in the wild species than were identified in the cultivated genotypes. Promising accessions for use in future breeding projects are listed in Table 4-21. These accessions were chosen based on their antioxidant activity as well as the levels of individual phenolic components.

TABLE 4-21 – *Promising accessions for future breeding projects aimed at increasing antioxidant activity and phenolic levels in potato*

<b>Accession</b>	<b>ID</b>	<b>Species</b>
184774	FFAO 52	<i>pinnatisectum</i>
320266	320266.17	<i>commersonii</i>
230489	HERB 4.1-.9	<i>pinnatisectum</i>
275235	HERB 11.1-.9	<i>pinnatisectum</i>
275234	HERB 10.1-.3	<i>pinnatisectum</i>
253214	HERB 5.1-.8	<i>pinnatisectum</i>
275233	HERB 9.1-.9	<i>pinnatisectum</i>
473243	FFAO 68	<i>tarijense</i>
275231	TAX 31	<i>pinnatisectum</i>
184774	HERB1.1-.6	<i>pinnatisectum</i>
197760	AO 10.3	<i>chacoense</i>
275232	TAX 32	<i>pinnatisectum</i>
197760	AO 10.7	<i>chacoense</i>
275232	HERB 8.1-.8	<i>pinnatisectum</i>
190115	TAX 30	<i>pinnatisectum</i>
275230	HERB 6.1-.9	<i>pinnatisectum</i>
283109	FFAO 65	<i>stoloniferum</i>
275262	AO 28.7	<i>jamesii</i>
186553	HERB 2.1-.9	<i>pinnatisectum</i>
275231	HERB 7.1-.9	<i>pinnatisectum</i>
275236	TAX 33	<i>pinnatisectum</i>
218225	AO 34.18	<i>microdontum</i>
498383	FFAO 37	<i>megistacrolobum</i>
275262	AO 28.13	<i>jamesii</i>
275262	AO 28.2	<i>jamesii</i>
341233	TAX 71	<i>cardiophyllum</i>
473190	FFAO 42	<i>oplocense</i>
241235	TAX 72	<i>Cardiophyllum</i>
473481	FFAO 2	<i>Acaule</i>



## CHAPTER V

### DIFFERENTIATING SEVEN RUSSET NORKOTAH STRAINS USING AFLP AND MICROSATELLITE MARKER ANALYSIS

#### **Introduction**

The potato cultivar Russet Norkotah was released in 1987, and it quickly became the early market variety of choice in the national marketplace. Due in great part to wide promotion, by 1997, Russet Norkotah had become the second most popular variety in the U.S., with over 23,000 acres of certified seed grown in the U.S. and Canada (National Potato Council 1998). The popularity of Russet Norkotah is largely attributed to factors such as attractive tubers, tuber uniformity, resistance to hollow heart and second growth, good storability, and a high percentage of count-carton tubers. While outweighed by positive features, Russet Norkotah also has some negative characteristics such as susceptibility to PVY and verticillium wilt, weak vines, and requirements for large inputs of nitrogen fertilizers and pesticides. Russet Norkotah was in high demand in the potato industry, but its weak vines and other negative characteristics made it unsuitable for growing in Texas. It became obvious that improved Russet Norkotah strains with stronger vines would be required for the Texas industry to remain competitive.

Previous years of breeding and selection efforts had proven that potato varieties could be improved through strain selection. Notable successes include Russet Burbank from Burbank (Miller 1954), Red LaSoda from LaSoda (Miller 1954), Dark Red Norland from Norland, and Norgold Russet Strain M from Norgold Russet (Miller *et al.* 1995). Following the example set by the success with Norgold Russet, the Texas Potato Variety

Development Program (and later the Colorado State University Breeding Program) began to make selections and evaluate improved strains of Russet Norkotah (Miller *et al.* 1999). By 1998, a nine year selection project, based primarily on yield, vine size, and tuber type had produced eight promising intracloonal selections of Russet Norkotah. These were TXNS 102, TXNS 112, TXNS 223, TXNS 249, TXNS 278, TXNS 296, CORN 3, and CORN 8. Five of these, TXNS 112, TXNS 223, TXNS 278, CORN 3, and CORN 8 have been granted Plant Variety Protection (PVP). By 1999, 38% of the Russet Norkotah acreage entered into seed certification was to one of these five strains (National Potato Council 2000), with acreage of the strains increasing every year. By 2001, 42% of the U.S. Russet Norkotah acreage entered into certification was planted to the strains (National Potato Council 2002), and by 2002, over half (52%) (National Potato Council 2003). The intracloonal selections from both the Colorado and Texas programs exhibit higher yield, lower nitrogen requirements, later maturity, longer flowering periods, larger tuber size, and generally higher specific gravity than standard Russet Norkotah (Miller *et al.* 1999; Zvomuya *et al.* 2002)

Despite some quantitative differences between the strains and standard Russet Norkotah, it can be difficult to distinguish them from one another. Molecular markers could help to distinguish these different selections and aid in the granting of PVP in the U.S. and/or Plant Breeder's rights in Canada to additional strain selections. Furthermore, having markers that differentiate the strains could help to determine if there is an infringement of patent rights in the future.

Previous research has demonstrated that both the AFLP and microsatellite approaches are promising for differentiating between cultivars, and potentially, somatic mutants.

AFLPs have a high multiplex ratio, thus generate volumes of data, while SSRs are highly polymorphic and have been successful in discriminating between closely related species. Several successful studies have been conducted on potato using AFLP and SSR analysis (Provan *et al.* 1996; Milbourne *et al.* 1997; McGregor *et al.* 2000; Milbourne *et al.* 1988; Raker and Spooner 2002; Schneider and Douches 1997; Kardolus 1998; kim *et al.* 1998a; Meksem 1995; Meyer *et al.* 1998 ). Thus, a multifaceted approach using the aforementioned techniques could reasonably be employed to distinguish between the Russet Norkotah clonal selections.

The focus of this study was on AFLPs and SSRs - markers with high multiplex ratios (meaning a large number of markers can be generated in a single reaction) and good reproducibility (AFLPs) and highly polymorphic markers (microsatellites). The primary objective of this study was to identify polymorphisms among six intracloonal variants of the potato cultivar Russet Norkotah. Any polymorphisms discovered would provide additional evidence supporting granting of individual plant variety protection to strain selections.

## **Materials and Methods**

Six clonal selections (TXNS112, TXNS223, TXNS278, TXNS296, CORN3, and CORN8), standard Russet Norkotah, and a white-flesh chipping Texas breeding line, ATX85404-8W, were subjected to AFLP analysis to identify DNA markers that differed among the strains and/or between the strains and standard Russet Norkotah.

### ***DNA Isolation and Concentration***

DNA was isolated from leaves of potato plants grown near Springlake, Texas in the spring of 1999 using a procedure developed by Fulton (1995). Samples were collected from single plants in the field, and immediately frozen in liquid nitrogen for transport to College Station. Upon arrival, the plants were stored in a  $-80$  C freezer until the following day when extractions were performed (Appendix A). The DNA concentration of each of the genotypes was determined based on the absorbance at 260nm using the following formula:  $(\text{Absorbance } 260\text{nm})(4)(1000)=\text{ng/ul}$ . Following the determination of concentration, each genotype's DNA was diluted to a concentration of 50ng/200ul.

### ***AFLP Analysis I – Visualized via Silver Staining***

A modified AFLP system, which was designed for use with plants having genomes ranging in size from  $5 \times 10^8$  to  $6 \times 10^9$  bp, was used with minor modifications (Life Technologies, Gaithersburg, MD.). This technique involved restriction endonuclease digestion of the DNA, ligation of adapters, amplification of the restriction fragments, and gel analysis of the amplified fragments (Life Technologies, ND) (Figure 5-1).

*Digestion of Genomic DNA* - The DNA of each of the eight genotypes was simultaneously digested with two restriction enzymes: EcoRI and MseI. The digestion was carried out according to manufacturer's instructions, with the reaction volume reduced by one fourth (Appendix B). EcoRI has a 6bp recognition site, while MseI has a

4bp recognition site; thus, the types and number of fragments generated were as follows:  
MseI-MseI>>MseI-EcoRI>>EcoRI-EcoRI.

*Ligation of Adapters* - Specific double-stranded dinucleotide adapters were ligated to the restricted DNA fragments (Table 5-1). This was done according to manufacturer's instructions with the reaction volume reduced by one fourth. The resulting product was referred to as restricted adapter-ligated diluted DNA (RAD).

*Preamplification* - Preamplification followed the ligation of the adapters to the digested DNA, and involved using oligonucleotides homologous to the adapters, but having extensions at the 3' end to amplify a subset of the DNA fragments. The primers used had a 1-nucleotide extension on the 3' end of the primer. The selective nature of AFLP-PCR is based on these 3' extensions on the oligonucleotide primers. Since the extensions were not homologous to the adapter sequence, only DNA fragments complementary to the extensions were amplified. Taq DNA polymerase (DNAP) cannot extend DNAs if mismatches occur at the 3' end of the molecule being synthesized. Due to the fact that primers are directional, preselective amplification targeted the MseI-EcoRI fragments and excluded the MseI-MseI and EcoRI-EcoRI fragments.

Preamplification was performed according to manufacturers' instructions with the reaction volume reduced by one fourth (Appendix C). The resulting PCR reaction was prepared for selective amplification by diluting the preamplification DNA 1:10 with TE. This was termed the Template for Selective Amplification (TSA). The two preamplification primers provided with the kit were used (Table 5-1).

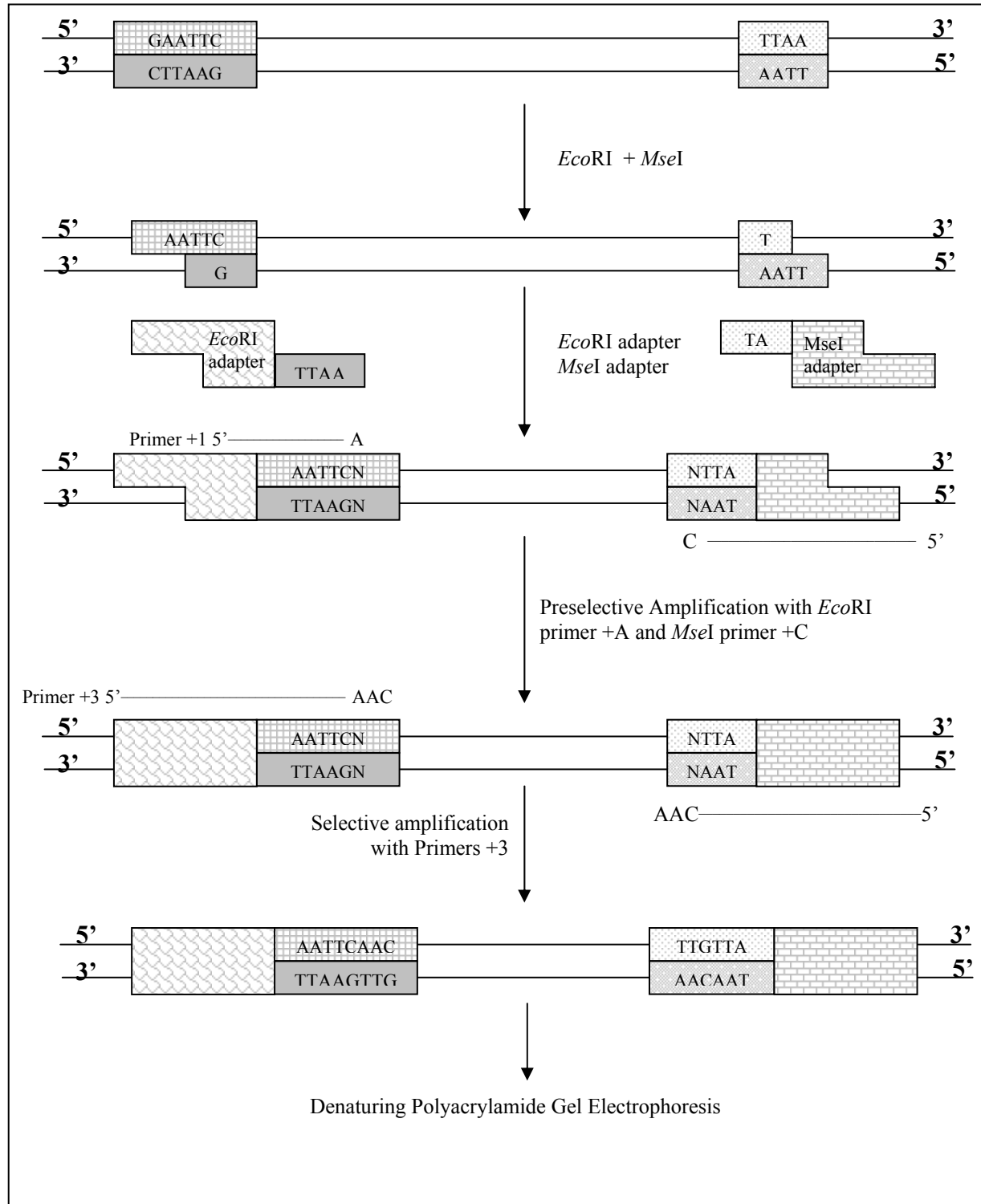
*Selective Amplification* - Following preamplification, selective amplification was performed using primers with three selective bases on the 3' end. This was performed

according to manufacturers' instructions with the reaction volume reduced by half (Appendix D). Sixty-four combinations of EcoRI and MseI AFLP primers supplied by the manufacturer were used for selective amplification (Table 5-1). Following amplification, reaction products were dried in a speed vac at medium speed for ~30 minutes (Savant, Holbrook, NY), and were resuspended in 5ul of water and 5ul of formamide manual sequencing dye (Sambrook *et al.* 1989) (Appendix E). The resulting mixture was denatured for three minutes at 90 C and quickly cooled on ice.

TABLE 5-1 - *Primer sequences for adapters, pre-amplification primers and selective amplification primers for AFLP analysis System I.*

Oligonucleotide	Primer Sequence	Length (bp)
MseI Adapter 1	5'-GAC GAT GAG TCC TGA G-3'	16
MseI Adapter 2	3'-TAC TCA GGA CTC AT-5'	14
EcoRI Adapter 1	5'-CTC GTA GAC TGC GTA CC-3'	17
EcoRI Adapter 2	3'-CAT CTG ACG CAT GGT TAA-5'	18
EcoRI PreAmp Primer	5'-GAC TGC GTA CCA ATT CA-3'	17
MseI PreAmp Primer	5'-GAT GAG TCC TGA GTA AC-3'	17
M-CNN*	5'-GAT GAG TCC TGA GTA CAN N-3'	19
E-ANN*	5'-GAC TGC GTA CCA ATT CAN N-3'	19

\*NN depicts two nucleotides. The selective nucleotides for *MseI* included CTA, CTG, CTC, CTT, CAA, CAG, CAC, and CAT, and those for and *EcoRI* included AAG, AAC, ACC, ACT, ACG, ACA, AGG, and AGC.



**FIGURE 5-1.**

**Diagram of the AFLP procedure using a single primer pair. Demonstrates restriction, ligation of adapters, preamplification, and selective amplification.**

*Polyacrylamide Gel Electrophoresis* - Each sample (2ul) was loaded on a 6% denaturing (sequencing) polyacrylamide gel (Appendix G). Two glass plates (42cm and 39cm) were prepared according to the silver staining protocol described by Fritz *et al.* (1999) (Appendix F) and placed together with 0.4mm spacers.

Following polymerization, the gels were pre-warmed on a Life Technologies Inc. S2 upright gel apparatus while the samples were denatured. Two ul of each sample were loaded on the gel and allowed to run until the dye band was  $\frac{3}{4}$  of the way down the plate. The gels were then removed from the gel apparatus and silver stained according to Fritz *et al.* 1999 (Appendix F).

*Scoring of Gels* - Gels were scored manually for presence or absence of bands.

### ***AFLP Analysis II – LiCOR Analysis***

Contrary to the previous method, this AFLP analysis was conducted using fluorescently labeled primers and a LI-COR model 4200 sequencer with Tionumerics software (Applied Maths, Kortrijk, Belgium). The same basic concepts conveyed in the previous section still hold true; however, there were modifications in the methods which are detailed below.

*Digestion of Genomic DNA* - The DNA from each of the eight genotypes was sequentially digested with *EcoRI* and *PstI* according to Menz (2002) (Appendix H). The decision to use *PstI* in lieu of the *MseI* used previously had to do with the fact that *MseI* is a methylation sensitive enzyme, while *PstI* is not. In other words, *PstI* digests DNA regardless of its methylation state. Since methylation of DNA is a silencing mechanism, it could explain differences between the clones, and it was potentially useful



to look at banding patterns using methylation sensitive as well as methylation insensitive enzymes in the AFLP analysis. Since, however, the *Pst*I enzyme digests a GC rich region, and expressed regions frequently are rich in GC content, even though both methylated and non-methylated regions would be digested, expressed regions would still be preferentially digested and subsequently amplified.

*Ligation of Adapters* - Specific double-stranded dinucleotide adapters were ligated to the restricted DNA fragments (Table 5-2). This was accomplished by mixing 1ul of the 10X ligation buffer, 1ul of 50pmol/ul Mse adaptor, 1ul of 5pmol/ul PstI adapter, 1ul of T4 DNA ligase, and 6ul of ddH<sub>2</sub>O. This formed what was referred to as the restriction x adapter mix. After incubating at 37°C overnight, 440ul of water was added to dilute the restriction x adapter mix. The resulting mixture was termed restricted, adapter-ligated diluted DNA (RAD) (Appendix I).

*Preamplification* - After optimizing the MgCl<sub>2</sub> concentration, preamplification was performed according to Klein (2000) with minor modifications. 20ul reactions were performed using 5ul RAD template, 2.5ul 10X PCR buffer, 0.75ul 50mM MgCl<sub>2</sub>, 2.0ul 2.0mM dNTPs, 1.4ul *Pst*+*C* pre-amp primer (10pmol/ul), 1.4ul of Mse+O pre-amp primer (10pmol/ul), 0.2ul Taq DNAp (Promega), and 11.75 of ddH<sub>2</sub>O. The sequence of the primers is shown in Table 2. The PCR profile was identical to that of Klein *et al.* (2000), except 25, as opposed to 20, cycles were performed. (Appendix J). The resulting product was diluted 1:10 with water, and run on a 1% agarose gel to verify amplification.

*Selective Amplification* - Following preamplification, selective amplification was performed using primers with three selective bases on the 3' end. For visualization

purposes, the *PstI* selective primer was labeled with IRD dye (LI-COR). 10ul selective amplification reactions were set up by combining 1ul 10X PCR buffer, 0.5ul 25mM MgCl<sub>2</sub>, 1ul of 2mM dNTPs, 0.15ul of ~1uM *PstI*-primer (IRD labeled), and 0.5ul *MseI* primer. This was combined with 2ul of TSA (template), and subsequently diluted with 4.81ul ddH<sub>2</sub>O. Samples were mixed in the dark due to the light-sensitive nature of the *PstI* primer. The PCR reaction was run under the following profile. Cycle one began with a two minute hold at 95 C followed by continued denaturing for 1 minute at 94 C, a 1 minute annealing step at 65 C, and a 1 minute 30 second extension at 72 C. The annealing step was reduced by 0.6 C each cycle for the next 12 cycles, giving a touch down phase of 13 cycles. Twenty-three cycles were then performed with an annealing temperature of 56°C. Following these 23 cycles, an additional extension step at 72 C at five minutes was performed followed by a 4 C hold (Appendix K).

For this experiment, three different *PstI* primers (CGT, CTT and CAA) were used. CTT and CGT were labeled with IRD dye that absorbed at 800nm, and CAA was labeled with dye that absorbed at 700nm. Thus, it was possible to run two different IRD-labeled *PstI* primers, one visualized at 700nm, and one visualized at 800nm, simultaneously in each well. Using different wavelengths on primer labels allowed the running of twice as many primer pairs per gel as was previously possible. The same 16 unlabelled *MseI* primers used in the silver staining analysis were used for the LI-COR analysis. Each of these 16 primers were run with each of the three *PstI* primers, producing a grand total of 48 different primer combinations used in the selective amplification for the LI-COR analysis (Table 5-2).

TABLE 5-2 - *Primer sequences for adapters, pre-amplification primers and selective amplification primers for LI-COR.*

Oligonucleotide	Primer Sequence	Length (bp)
MseI Adapter 1	5'-GAC GAT GAG TCC TGA G-3'	16
MseI Adapter 2	3'-TAC TCA GGA CTC AT-5'	14
PstI Adapter 1	5'- GAC TGC GTA GGT GCA-3'	15
PstI Adapter 2	3' – CCT ACG CAG TCT ACG AG- 5'	17
<i>PstI</i> PreAmp Primer	5'-GAC TGC GTA GGT GCA G-3'	17
MseI PreAmp Primer	5'-GAT GAG TCC TGA GTA AC-3'	17
<i>MseI</i> -CNN*	5'-GAT GAGTCCTGAGTAACNN-3'	19
<i>PstI</i> -ANN*	5'-GAC TGC GTA GGT GCA GCN N -3'	19

NN depicts two nucleotides. All 16 possible combinations of C, G, A, T were used in the place of these two Ns for the *MseI* selective primers. The selective nucleotides for *MseI* included CGC, CGT, CGA, CGG, CTC, CTT, CTA, CTG, CAC CAT CAA CAG, CCC, CCT, CCG, and CCA. Selective nucleotides for *PstI* primers were CAA (IRD dye labeled at 700nm), CGT, and CTT (IRD labeled at 800nm).

*Polyacrylamide Gel Electrophoresis* - Prior to loading, samples from two reactions, each absorbing at a different wavelength, were pooled into a single PCR plate in an orientation that allowed the gel to be loaded with an 8-channel syringe (Appendix L). Five ul of each sample amplified with a 700nm IRD selective p-primer, and 5ul of each sample amplified with an 800nm IRD selective p-primer were mixed together and 2ul of LI-COR basic fushion loading dye was subsequently added. The sample was then denatured at 95 C for 2.5 minutes and placed on ice.

The AFLP amplification products were analyzed using a LI-COR model 4200 dual-dye automated DNA sequencing system. Each sample (1ul) was loaded on a 6% LongRanger polyacrylamide gel containing 7M urea (Appendix M), and cast using LI-COR 25cm plates with 0.25mm thick spacers and comb. Electrophoresis was conducted

at a constant power of 40 W and a constant temperature of 47.5 C for 3 hours. When lower bands were not separated satisfactorily, a 7% LongRanger polyacrylamide gel was used.

*Analysis of Gels* - The raw data from the LI-COR sequencers was converted to a gel-like image that was stored in a TIFF format. Gels were scored visually for presence or absence of bands.

### ***Microsatellite Analysis***

Microsatellites were used as an alternative to the AFLP method in the hope that it would reveal more differences between the subclonal variants. Twelve potato microsatellite primers, originally identified by Milbourne, *et al.* (1998) were used in this analysis (Table 5-3). Reaction conditions were modified from Raker and Spooner (2002) (Appendix N). Conditions for a 25ul reaction were as follows: 1X PCR Buffer (Sigma), 1.5mM MgCl<sub>2</sub>, 0.2mM dNTPs (Gibco BRL), 0.4uM of each unlabelled primer pair (Sigma Genosys), 1U DNAP (REDTaq, Sigma), and 20ng DNA. The PCR profile followed was identical to that of Raker and Spooner (2002) (Appendix N).

TABLE 5-3- *Primer sequences microsatellite primers used in this study. (Milbourne et al. 1998)*

Primer	Primer sequence	Length (bp)	T <sub>m</sub>	Chromo #
STM0003-f	5'-GGA GAA TCA TAA CAA CCA G- 3'	19	48	XII
STM0003-r	5'-AAT TGT AAC TCT GTG TGT GTG-3'	21	48	XII
STM0007-f	5'-GGA CAA GCT GTG AAG TTT AT-3'	20	52	XII
STM0007-r	5'-AAT TGA GAA AGA GTG TGT GTG-3'	21	52	XII
STM0014-f	5'-CAG TCT TCA GCC CAT AGG - 3'	18	53	I
STM0014-r	5'-TAA ACA ATG GTA GAC AAG ACA AA-3'	23	53	I
STM0051-f	5'-TAC ATA CAT ACA CAC ACG CG-3'	20	53	X
STM0051-r	5'-CTG CAA CTT ATA GCC TCC A-3'	19	53	X
STM1005-f	5'-ATG CCT CTT ACG AAT AAC TCG G-3'	22	59	VIII
STM1005-r	5'-CAG CTA ACG TGG TTG GGG-3'	18	59	VIII
STM1017-f	5'-GAC ACG TTC ACC ATA AA-3'	17	48	IX
STM1017-r	5'-AGA AGA ATA GCA AAG CAA-3'	18	48	IX
STM1024-f	5'-ATA CAG GAC CTT AAT TTC CCC AA-3'	23	59	VIII
STM1024-r	5'-TCA AAA CCC AAT TCA ATC AAA TC-3'	23	59	VIII
STM1029-f	5'-AGG TTC ACT CAC AAT CAA AGC A -3'	22	58	I
STM1029-r	5'-AAG ATT TCC AAG AAA TTT GAG GG-3'	23	58	I
STM1041-f	5'-GTT GAG TAG AAG GAG GAT T-3'	19	53	V
STM1041-r	5'-CCT TTG TCT TCT GCT TTT G-3'	19	53	V
STM1049-f	5'-CTA CCA GTT TGT TGA TTG TGG TG-5'	23	58	I
STM1049-r	5'-AGG GAC TTT AAT TTG TTG GAC G-3'	22	58	I
STM2022-f	5'-GCG TCA GCG ATT TCA GTA CTA-3'	21	57	II
STM2022-r	5'-TTC AGT CAA CTC CTG TTG CG-3'	20	57	II
STM3009-f	5'-TCA GCT GAA CGA CCA CTG TTC-3'	21	63	VII
STM3009-r	5'-GAT TTC ACC AAG CAT GGA AGT C-3'	22	63	VII

Following amplification, reaction products were dried in a speed vac at medium speed for ~30 minutes (Savant, Holbrook, NY), and were resuspended in 5ul of water and 5ul of formamide manual sequencing dye (Sambrook *et al.* 1989) (Appendix E). The resulting mixture was denatured for three minutes at 90 C and then quickly cooled on ice.

*Polyacrylamide Gel Electrophoresis* - One ul of the concentrated PCR samples was loaded on a 6% denaturing (sequencing) polyacrylamide gel (Appendix G). Two glass plates (42cm and 39cm) were prepared according to the silver staining protocol described by Fritz *et al.* (1999) (Appendix F) and placed together with 0.4mm spacers.

Following polymerization, the gels were pre-warmed on a Life Technologies, Inc. S2 upright gel apparatus while the samples were denatured. Two ul of each sample were loaded on the gel and allowed to run until the dye band was one-half of the way down the plate. The gels were then removed from the gel apparatus and silver stained according to Fritz *et al.* 1999 (Appendix F).

*Scoring of Gels* - Gels were scored manually for presence or absence of bands.

## **Results and Discussion**

### ***AFLP Analysis***

For discrimination between the strains, a total of 112 AFLP primer combinations were tested. These included both the 68 MseI/EcoRI primers, which amplified non-methylated regions, and the 48 MseI/PstI primers, which amplified both methylated and non-methylated regions. A representative gel is pictured in Figure 5-2. None of these primers were able to detect reliable polymorphisms among the seven Russet Norkotah

intraclonal variants, despite the scoring of 3,755 markers. Some polymorphisms were observed, but were not confirmed with subsequent analysis of the same DNA, and were thus assumed to be amplification artifacts. With silver staining, 29 (1.4%) irreproducible polymorphisms were observed among the 2,042 bands scored, while 42 (2.4%) were produced with fluorescent detection. These numbers are within the bounds of error of previous studies suggesting an AFLP error rate of ~2% (Arens *et al.* 1998; Winfield *et al.* 1998).

Work conducted by Monte-Corvo *et al.* (2001), suggests that the difference in the percent of irreproducible polymorphisms between silver staining and other forms of visualization are due to the fact that many of the weak markers responsible for false polymorphisms are not detectible with silver staining. This is supported by the average number of bands per primer, with Li-Cor primers producing an average of 44 bands per primer, while silver staining produced 33. This again points to the superior resolution of the Li-Cor system. Eleven primer combinations were not scored due to poor amplification or background on the silver-stained gels. Despite the inability to distinguish between the seven Russet Norkotah strains, a 14.4% difference was detected between the Russet Norkotah clones and the breeding line ATX85404-5W.

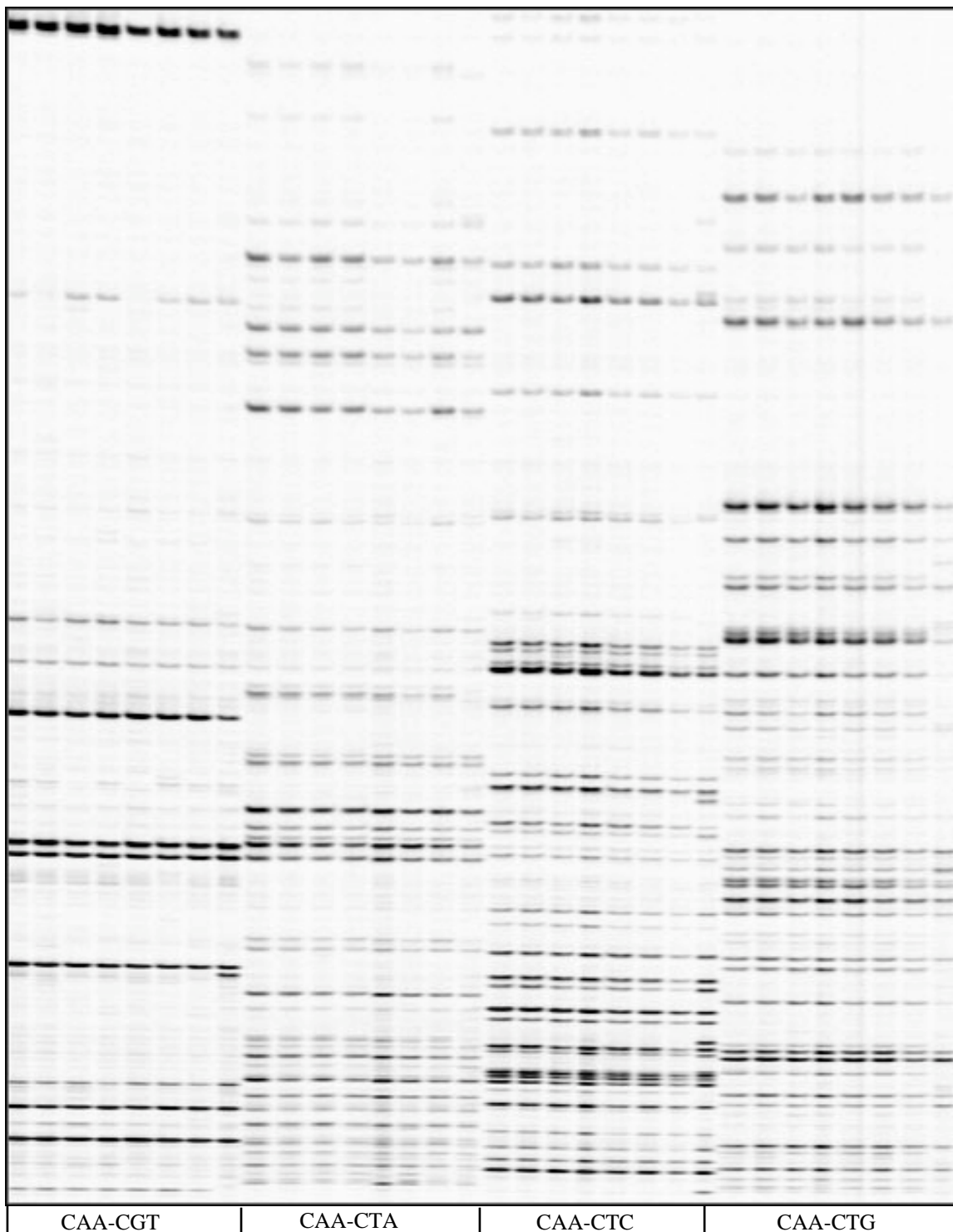


Figure 5-2.

A picture of a representative Li-Cor gel with 4 different *MseI/PstI* primer pairs is shown above. The genotypes, in order from left to right for each primer pair, are CORN3, TXNS223, TXNS112, TXNS278, TXNS296, CORN8, Russet Norkotah, and ATX85404-8W. It is clearly demonstrated that ATX85404-8W has a different AFLP pattern from the rest of the genotypes, while Russet Norkotah and its clones are indistinguishable from one another.

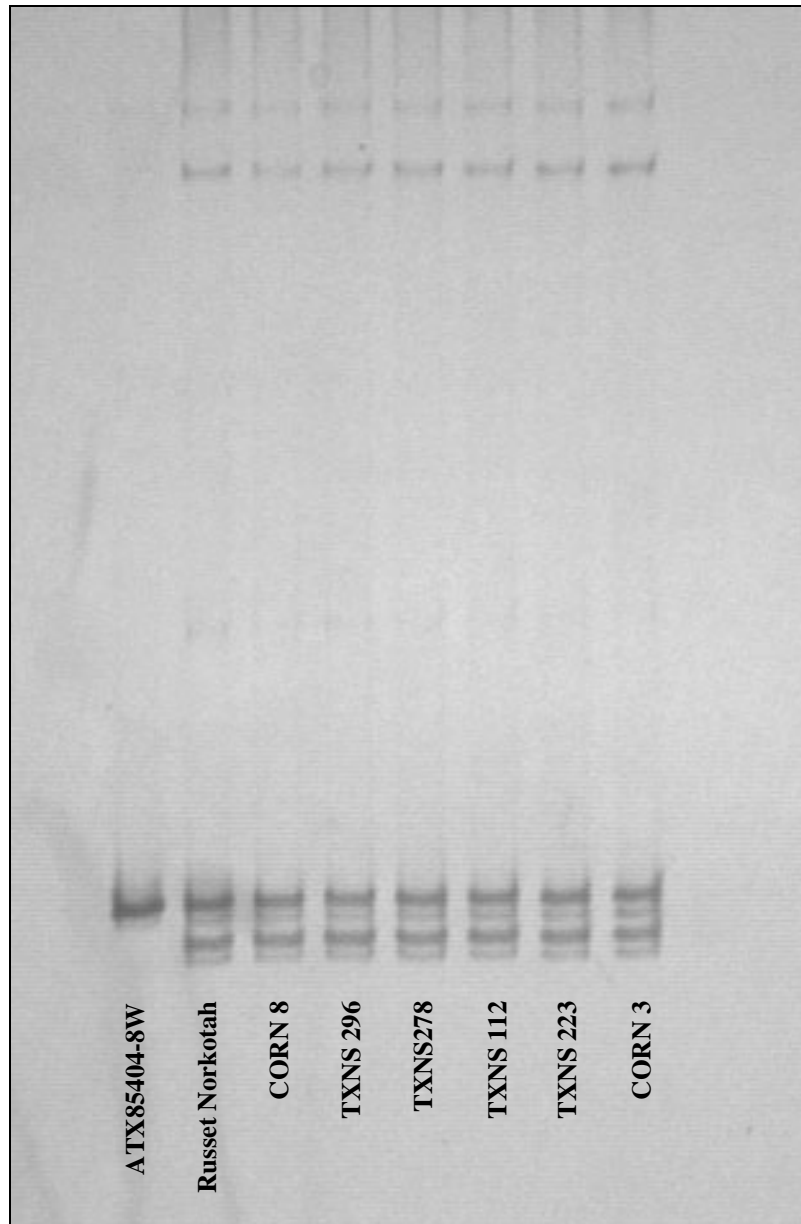


### ***Microsatellite Analysis***

A total of 45 microsatellite primers were scored for 11 primer combinations. Primer Stm1049 was not included in the analysis because it failed to produce amplification products in two attempts. The third attempt produced multiple (26) inconsistent bands. Due to the inconsistencies, this primer was not included in the final analysis. The remaining 11 primers produced an average of 4.1 bands per primer with no polymorphisms between 'Russet Norkotah' and its strains. Twelve bands (26.7%) were polymorphic between ATX85404-8W and Russet Norkotah. A typical microsatellite gel is depicted in Figure 5-4.

### **Discussion**

The inability to detect differences with molecular markers between the clones does not suggest that they are genetically identical, but rather extremely similar. The seven Russet Norkotah clones clearly show differences in phenotypic traits such as increased yield, larger vine size, generally higher specific gravity, and lower nitrogen requirements (Miller *et al.* 1999; Zvomuya *et al.* 2002) (Figure 5-4). These differences could be a result of somatic variation. The absence of polymorphisms suggests that these mutations are restricted to a small part of the genome.



**Figure 5-3.**

A typical microsatellite gel depicting differences between ATX85404-8W on the left, but no differences between Russet Norkotah and its strains. From left to right are ATX85404-8W, Russet Norkotah, CORN8, TXNS296, TXNS278, TXNS112, TXNS223, and CORN3.

The PCR products generated from different individuals reflect the length of the amplified region, but not the particular sequence of that region. Therefore, a difference in sequence could be present between the clones, but would not be detected if it does not alter the length of the amplified region.

Lack of molecular evidence could also be explained by differences in methylation. Although a methylation sensitive enzyme was used in this study, unless a restriction site was differentially methylated between standard Russet Norkotah and the clones, methylation differences would not be evident. Since restriction sites represent a very small percentage of the genome, chances are, if there are methylation differences between the clones, they will not occur within these restriction sites.

While differences in mitochondrial DNA have proven in the past to be involved in somoclonal variation, it is unlikely that this holds true in the case of the Russet Norkotah subclones (DeVerno, *et al.* 1994). Since cytoplasmic DNA is randomly distributed during cell division, it's logical to assume that a phenotype-based mitochondrial or chloroplast DNA would vary over time. This is demonstrated by the reversion to wild type of many tissue culture variants. However, this has not been observed in the Russet Norkotah intraclonal variants, as they reproduce true to type.



**FIGURE 5-4.**

**Russet Norkotah and clonal selections in the 1999 Arizona nursery. Pictured from left to right are TXNS112, TXNS223, Russet Norkotah, TXNS278, CORN3, and CORN8. Increased vigor is evident in the strains.**

Meyer, *et al.* (1998) point out the complications of using a tetraploid species in an AFLP analysis. While AFLPs are known for their high multiplex ratios, in tetraploids much of the polymorphism is masked by 'dosage.' Since AFLPs are frequently dominant markers, due to the presence or absence of a priming site, one would not see differences if this presence or absence was masked by another copy of that site. That is, if there are 4 copies of a gene, for example AAAa, and it is mutated to AAaa, one would not see this difference. For example, in a diploid species, there are two copies of the hypothetical gene "A". If the genotype is Aa, and the priming site falls in the middle of the "A" form of the gene, a mutation from "Aa" to "aa" would cause a loss of this priming site, and the corresponding loss of a band. In a tetraploid, however, if the genotype is changed from AAAa to Aaaa, the "A" allele would still be present, and a band would still be produced for this allele. Thus, it is possible that one chromosome of the four in Russet Norkotah was mutated in the clones, but since we cannot reliably discriminate between band intensity, it was not detected.

Many studies have been performed on somoclonal variation, and the resulting literature can provide insight into possible explanations for differences in the Russet Norkotah clones. Since the early 1980's, researchers have been trying to determine the underlying cause of tissue culture derived variants, and possible explanations have included everything from gross chromosomal rearrangements to more cryptic changes such as methylation. Frequent explanations are inversions, deletions, translocations, polyploidization, transposon activation, point mutations, and methylation (Larkin and Scowcroft, 1981).

While chromosome breakage is probably accentuated by tissue culture conditions, it is still a possibility in the case of the Russet Norkotah clones. When such rearrangement occurs, there is a great potential for loss of genetic material. Furthermore, it could affect genes in which a break occurs, as well as neighboring genes under the control of the same promoter. In addition, translocation of a gene can have a positional effect, with one possible result the silencing of a previously expressed gene. Should a dominant allele be “turned off” the phenotype of the recessive allele will be expressed, thus leading to an altered phenotype (Larkin and Scowcroft, 1981). While it may seem unlikely that screening the genotypes with 112 AFLP primers would miss such an event, it is, in fact, very plausible. Unless a deletion occurs within two restriction sites, it would go undetected. Furthermore, an inversion, if it doesn't alter the length of an amplified fragment, would also go undetected.

While microsatellites revealed more polymorphism between ATX85404-8W and Russet Norkotah than did AFLPs, they were still unable to distinguish between Russet Norkotah and the strains. Since the clones are so closely related to Russet Norkotah, and the mutations in the strains of this cultivar are clearly expressed, this is not surprising. Only 12 microsatellite primers were used, and these did not encompass all 12 of the potato chromosomes. Chromosomes III, IV, and VI were not represented. Therefore, either the genetic differences between Russet Norkotah and the strains are not in a microsatellite region, or a broad enough sample of primers was not screened.

Clearly, there are stable genetic differences between Russet Norkotah and its strains, but the right marker system to uncover these differences has not been found. Point mutations might better be identified by techniques such as single-strand

confirmation polymorphism (SSCP), temperature gradient gel electrophoresis (TGGE), or denaturation gradient gel electrophoresis (DGGE). The usefulness of these techniques in discriminating between clonal variants is currently under investigation by Monte-Corvo *et al.* (2001). Another possible technique to detect differences between these and other clonal variants is to utilize the relatively new high-throughput “gene chip” technology. This fascinating new approach theoretically allows the researcher to place DNA sequences representing all of the genes in an organism on small glass supports, and subsequently use these genes as hybridization substrates to quantitate the expression of the genes represented in a complex mRNA sample (Somerville and Somerville, 1999). Differential expression of the genes in Russet Norkotah and its clones could lead to the discovery of the genes responsible for their variant phenotypes.

## CHAPTER VI

### CONCLUSIONS

High levels of variability were found in total antioxidant activity among 138 cultivated genotypes when analyzed using the DPPH assay. Ninety-one genotypes from Field Day Trial 2000 and 100 genotypes from Field Day Trial 2001 were analyzed. Activities in the Field Day Trial 2000 ranged from 104  $\mu\text{g}$  trolox eq/gfw (A8792-1) to 565  $\mu\text{g}$  trolox eq/gfw (Purple Peruvian), and those from Field Day Trial 2001 ranged from 108  $\mu\text{g}$  trolox eq/gfw (NDTX4304-1R) to 59  $\mu\text{g}$  trolox eq/gfw (Stampede Russet).

Fifty-three genotypes were common between Field Day Trial 2000 and 2001. Analysis of variance revealed significant differences between genotypes, years, and genotype x year interactions, but no significant differences were found between replications. The genotypes which ranked high in both years were Russet Norkotah, ATX91137-1Ru, ATX9202-1Ru, CORN8, Ranger Russet, ATX92230-1Ru, Stampede Russet, BTX1810-1R, TXNS296, and COTX93053-4R.

Six advanced selections and 11 named varieties were grown in Dalhart, Texas in 2000 and compared to the tubers grown in Springlake, Texas in Field Day Trial 2000 to determine the effect of location on antioxidant activity. Analysis of variance revealed significant differences between varieties and locations but not between replications. Tubers grown in Springlake in the Field Day Trial 2000 were 1.6 fold higher in antioxidant activity than those grown in Dalhart.



Significant differences were found among Russet Norkotah and its intracloonal variants, in both Field Day Trial 2000 and Field Day Trial 2001. No significant differences were found between replications.

To determine how potato compared to other vegetables, eighteen different store-bought vegetables were analyzed for antioxidant activity. Bell pepper had the highest antioxidant activity (751  $\mu\text{g}$  trolox eq/gfw), while celery had the lowest (0  $\mu\text{g}$  trolox eq/gfw). Significant differences were found between vegetables.

Seven types of potato chips were analyzed for antioxidant activity to determine the effect of commercial processing on antioxidant activity. Terra Blues had the highest antioxidant activity (36  $\mu\text{g}$  trolox eq/gfw), and several types had an antioxidant activity of zero. These results indicate that commercially processed potato chips contain little or no antioxidant activity. It is not known if the low values for the chips were due to interference of the oil with the DPPH assay.

A high level of variability in antioxidant activity was found among the 417 populations, representing 47 *Solanum* species, which were analyzed. In the Bamberg 1 group, 30 accessions representing 27 species were analyzed. These populations were obtained from true potato seed, and were segregating. Significant differences were observed between accessions, but not replications. Six accessions had higher mean antioxidant activities than the highest mean values in cultivated varieties. These accessions are as follows: *S. pinnatisectum* (892  $\mu\text{g}$  trolox eq/gfw), *S. comersonii* PI 320266 (778  $\mu\text{g}$  trolox eq/gfw), *S. pinnatisectum* PI 184764 (744  $\mu\text{g}$  trolox eq/gfw), *S. oxycarpum* PI 607860 (742  $\mu\text{g}$  trolox eq/gfw), *S. jamesii* PI 564050 (622  $\mu\text{g}$  trolox eq/gfw), and *S. violaceimarmoratum* PI 498314 (580  $\mu\text{g}$  trolox

eq/gfw). The accession with the lowest antioxidant activity was *S. brachistotrichum* PI 545832 (48 µg trolox eq/gfw).

In the Bamberg 2 group, 65 segregating accessions representing 25 species were analyzed. Two field replications were included in the study. Significant differences were observed between accessions, species, and replications but not field replications. Twenty-five accessions had higher mean antioxidant activities than the highest mean values in cultivated varieties. Species that were among the top accessions included *S. spgazzinii*, *megistacrolobum*, *pinnatisectum*, *chacoense*, *acaule*, *demissum*, *microdontum*, *jamesii*, *fendleri*, *infundibuliforme*, *oplocense*, *tarijense*, *commersonii*, and *gourlayi*. *S. pinnatisectum* accessions were frequently very high in antioxidant activity. The accession with the highest antioxidant activity was *S. spgazzinii* PI 500053 (847 µg trolox eq/gfw), and the accession with the lowest antioxidant activity was *S. megistacrolobum* PI 265873 (160 µg trolox eq/gfw).

Fifty segregating accessions of *S. jamesii* were analyzed for antioxidant activity. Significant differences were observed between accessions and replications. Nine accessions had exceptionally high antioxidant activities (above 800 µg trolox eq/gfw). These accessions were as follows: PI 603056, PI 595784, PI 603055, PI 275172, PI 275266, PI 275262, PI 458424, PI 592399, and PI 275264.

Two-hundred-seventy-two clones, representing 23 species were analyzed for antioxidant activity in the Bamberg 02 group. These populations were obtained from tuber seed; thus within each group of samples, all tubers were clones. Significant differences were observed between accessions but not replications. *S. pinnatisectum* and *S. jamesii* clones were consistently high in antioxidant activity, while *S.*

*brachistotrichum* continually ranked low. Clones of *S. jamesii* accession PI 275262 appear to be consistently high in antioxidant activity. The clone with the highest antioxidant activity was *S. cardiophyllum* PI 341235, TAX 72 (884  $\mu\text{g}$  trolox eq/gfw). The clone with the lowest antioxidant activity was *S. brachistotrichum* PI 255528, TAX 42 (43  $\mu\text{g}$  trolox eq/gfw).

Based on the antioxidant assay of Field Day Trial 2001, the top 11 genotypes were subjected to HPLC analysis to determine phenolic content. The primary phenolics identified were chlorogenic acid, caffeic acid, and tryptophan, with minor amounts of rutin hydrate. Chlorogenic acid levels ranged from 26-329  $\mu\text{g}/\text{gfw}$ , but no significant differences were observed between genotypes. Caffeic acid levels ranged from 33-41  $\mu\text{g}/\text{gfw}$ . Significant differences were found between genotypes, while replications were insignificant. Rutin hydrate levels ranged from 7-306  $\mu\text{g}/\text{gfw}$ . Significant differences were observed between genotypes but not replications. Tryptophan was observed in all genotypes, but was not quantitated. The lack of detection of other compounds previously reported to be present in potato was probably due to the fact that quantitation was based on both retention time and spectra, while previous studies based quantitation solely on retention time.

Twenty-six accessions from Bamberg 2 representing 12 species and 2 field replications were analyzed in triplicate via HPLC for phenolic constituents. The primary phenolics identified were chlorogenic acid, caffeic acid, and tryptophan, with minor amounts of p-coumaric and salicylic acids. Chlorogenic acid levels ranged from 0-1836  $\mu\text{g}/\text{gfw}$ . *Pinnatisectum* PI 347766 had the highest level of chlorogenic acid (1818  $\mu\text{g}/\text{gfw}$ ). Significant differences were observed between accessions, but

not replications. Caffeic acid levels ranged from 45-149  $\mu\text{g/gfw}$ . *S. pinnatisectum* PI 347766 contained the highest level of caffeic acid (149  $\mu\text{g/gfw}$ ). Significant differences were found between accessions, but not between replications or field replications. Levels of chlorogenic and caffeic acids in some accessions far exceeded those found in cultivated potato. DPPH appeared to be a good indicator of the levels of chlorogenic and caffeic acid found in the tuber tissue analyzed.

Forty-nine accessions from Bamberg 2 representing 20 species were analyzed in triplicate via HPLC for phenolic content. The primary phenolics identified were chlorogenic acid, caffeic acid, tryptophan, and vanillic acid, with minor amounts of p-coumaric acid, epicatechin, t-cinnamic acid, rutin hydrate, and gallic acid. Chlorogenic acid levels ranged from 18-1117  $\mu\text{g/gfw}$ . Significant differences were observed between accessions, but not replications. Caffeic acid levels ranged from 34-1570  $\mu\text{g/gfw}$ . Significant differences were observed between accessions, but not replications. Levels of chlorogenic and caffeic acids in some accessions far exceeded those in cultivated potato. Vanillic acid levels ranged from 6-17  $\mu\text{g/gfw}$ . Significant differences were observed between accessions, but not replications. In the current study, vanillic acid was not identified in cultivated genotypes. P-coumaric acid, epicatechin, t-cinnamic acid, rutin hydrate, and gallic acid were identified in a small number of accessions. Of these compounds, only rutin hydrate was identified in cultivated genotypes.

Seven *S. jamesii* accessions from the 50 samples in the *S. jamesii* group were analyzed in triplicate for phenolic components using HPLC analysis. Chlorogenic, caffeic, and vanillic acids were identified. Chlorogenic acid levels ranged from 65-

105 µg/gfw. *Jamesii* PI 275262 had the highest level of chlorogenic acid (105 µg/gfw). Caffeic acid levels ranged from 157-268 µg/gfw.

A spectrophotometric screen for carotenoid content was conducted on 138 cultivated genotypes. Ninety-one genotypes from Field Day Trial 2000 and 100 genotypes from Field Day Trial 2001 were analyzed. In Field Day Trial 2000, ATX82539-4Ru had the highest total carotenoid content (366 µg carotenoid eq/100gfw), while A8893-1 had the lowest (148 µg carotenoid eq/100gfw). Significant differences were found between genotypes, while replications were insignificant. In Field Day Trial 2001, TX1674-1W/Y had the highest total carotenoid content (536 µg carotenoid eq/100gfw), while NDTX4304-1R had the lowest (97 µg carotenoid eq/100gfw). Significant differences were found between genotypes, while replications were insignificant.

Forty-four genotypes were common between 2000 and 2001, and analysis of variance revealed significant differences in total carotenoid content between genotypes and genotype x year interaction, but not between years or replications. Genotypes performing well in both 2000 and 2001 are as follows: TX1674-1W/Y, BTX1544-2W/Y, CORN8, BTX1749-2Ru/Y, ATX9202-1Ru, ATX91137-1Ru, TXNS296, Vivaldi, and CORN3. Significant differences were found among Russet Norkotah and its intracloonal variants, in both Field Day Trial 2000 and Field Day Trial 2001. No significant differences were found between replications.

Fourteen genotypes from Field Day Trial 2003 were analyzed to determine the effect of storage on carotenoid content. There was a substantial loss of carotenoids during storage. While Field Day Trial 2001 entries ranked in approximately the same

order in Field Day Trial 2003, Field Day Trial 2000 did not. Variance and mean levels of carotenoid content decreased with increasing time in storage. Comparison of data obtained from the three field day trials suggests that, when analyzing large numbers of genotypes, a more efficient extraction and screening method should be utilized in the broad screen, to reduce storage time and thus degradation of the samples.

Thirty accessions representing 27 species were analyzed for carotenoid content in the Bamberg 1 group. *Vernei* PI 458374 had the highest total carotenoid content (893  $\mu\text{g}$  carotenoid eq/100gfw), while *brachistortrichum* PI 545832 had the lowest total carotenoid content (151  $\mu\text{g}$  carotenoid eq/100gfw). Significant differences were found between genotypes, while replications were insignificant.

Sixty-two accessions, representing 22 species and two field replications were analyzed for carotenoid content in the Bamberg 2 group. *Demissum* PI498232 had the highest total carotenoid content (771  $\mu\text{g}$  carotenoid eq/100gfw), while *Papita* PI 249929 had the lowest (130  $\mu\text{g}$  carotenoid eq/100gfw). Significant differences were found between genotypes, while replications and field replications were insignificant.

Two-hundred forty three clones, representing 20 species were analyzed for carotenoid content in the Bamberg 02 group. *Pinnatisectum* PI 275231, TAX 31 had the highest total carotenoid content (888  $\mu\text{g}$  carotenoid eq/100gfw), while *spgazzinii* PI 500053, AO 60.5 had the lowest total carotenoid content (84  $\mu\text{g}$  carotenoid eq/100gfw). Significant differences were found between genotypes, while replications and were insignificant.

Twenty-five genotypes from Field Day Trial 2000 were analyzed via HPLC for carotenoid content. The only carotenoid identified was antheraxanthin. TX1674-1W/Y contained 14.45  $\mu\text{g}/100\text{gfw}$ , while ATX82539-4Ru contained 18.75  $\mu\text{g}/100\text{gfw}$  of this compound. Many other peaks matched retention times for standard compounds, but not spectra. Had the decision been made to match solely on retention time, many more compounds would have been quantitated.

Twenty-eight genotypes from Field Day Trial 2001 were analyzed via HPLC for carotenoid content. Neoxanthin and lutein were the only compounds identified. Sating contained 4.65  $\mu\text{g}$  neoxanthin/100gfw, and Platina and Morning Gold contained 8.25 and 8.9  $\mu\text{g}$  lutein/100gfw, respectively. Retention time matches were found for violaxanthin, neoxanthin, antheraxanthin, lutein, and zeaxanthin; however, the spectra did not match.

Fourteen genotypes from Field Day Trial 2003 were analyzed via HPLC for carotenoid content to determine the effect of storage. Lutein, violaxanthin, antheraxanthin, and neoxanthin were identified. Lutein concentrations ranged from 14.25-48.75  $\mu\text{g}/100\text{gfw}$ . ATX82539-4Ru, a white flesh variety, contained the highest level of lutein (48.75  $\mu\text{g}/100\text{gfw}$ ). Violaxanthin concentrations ranged from 11.95-39.55  $\mu\text{g}/100\text{gfw}$ , with the highest amount being identified in BTX1754-1W/Y. Antheraxanthin was only identified in BTX1754-1W/Y (18.40  $\mu\text{g}/100\text{gfw}$ ), and neoxanthin was identified in BTX1754-1W/Y (13.25  $\mu\text{g}/100\text{gfw}$ ) and BTX1544-2W/Y (13.10  $\mu\text{g}/100\text{gfw}$ ). Occasionally, retention time matches were found that did not match the spectra of the standards.

Fourteen accessions, representing 14 species from the Bamberg 1 group were analyzed via HPLC for carotenoid components. Lutein was the only carotenoid identified, ranging in concentration from 9.35-18.75  $\mu\text{g}/100\text{gfw}$ . Retention time matches were found for lutein, violaxanthin, neoxanthin, and zeaxanthin; however they failed to match the spectra.

Twenty-six accessions, representing 20 species from the Bamberg 2 group were analyzed via HPLC for carotenoid components. No peaks were found that corresponded to both retention time and spectra of carotenoid standards. Retention time matches were found for lutein only.

Twenty-two clones representing 18 species from the Bamberg 02 group were analyzed for carotenoid components via HPLC analysis. No peaks were found that corresponded to both retention time and spectra of carotenoid standards. Retention time matches were found for lutein, neoxanthin, zeaxanthin, canthaxanthin, and violaxanthin.

Despite the use of 112 AFLP primers and 11 microsatellite primers, no differences were detected among Russet Norkotah and its intraclonal variants. This suggests that a different approach might be better for differentiating potato subclones.



## CHAPTER VII

### SUMMARY AND RECOMMENDATIONS

Potato is the fourth most important food crop worldwide, and a staple in many diets. Due to its large per capita consumption, increasing the level of antioxidants in potato through breeding efforts could benefit mankind in general. This study provided baseline information regarding antioxidant levels in a wide range of potato genotypes including both cultivated and wild species. Important results and recommendations are as follows:

1. Cultivated genotypes of potato vary widely in antioxidant activity, phenolic compounds, and carotenoid content. Significant differences between genotypes suggest that antioxidant activity and contributing compounds are under genetic control.
2. Wild *Solanum* species contain a wider range of phenolic variation than do cultivated genotypes, suggesting that they could be important contributors to phenolic content if incorporated into breeding programs.
3. Due to their low levels of carotenoids, it is not recommended that wild *Solanum* species be used in breeding for increased carotenoid levels.
4. While large screens are important for identifying genotypes that are high in antioxidant components, care should be taken that not too many are analyzed at once. Due to the instability of the compounds, it is recommended that the extraction procedure be simplified for the broad screen. Once varieties containing

high levels of antioxidant compounds are identified, extractions should be performed again on fresh tubers for HPLC analysis.

5. Many peaks remained unidentified in both the phenolic and carotenoid HPLC analysis. Identification of these peaks would be the next logical step in the process. It is recommended that standards be obtained for carotenoid esters, carotenoid epoxides, and phenolic glycosides as a starting point.
6. The varieties identified in this screen should be incorporated into the breeding program to increase antioxidant levels in potato.
7. PCR-based marker analysis does not appear to be useful in separating intraclonal variants of potato. Perhaps a functional genomic approach which analyzes differential expression would be beneficial for separating the subclones. Since the intraclonal variants were different in antioxidant activity and carotenoid content, one possible approach for differentiating the strains would be to look for differences in antioxidant genes, many of which have known sequences.

## LITERATURE CITED

- Ahmad, K.U., and M. Kamal. 1980. Wealth from the potato. Dacca Press Sangstha, Dacca, Bangladesh.
- Al-Saikhan, M.S., L.R. Howard, and J.C. Miller, Jr. 1995. Antioxidant activity and total phenolics in different genotypes of potato (*Solanum tuberosum*, L.). J Food Sci 60(2):341-343
- Al-Saikhan, M.S. 2000. Antioxidants, proteins, and carotenoids in potato (*Solanum tuberosum*, L.). Ph.D. Dissertation, Texas A&M University, College Station.
- Ames, B. 1983. Dietary carcinogens and anticarcinogens. Science, new series 221:1256-1264.
- Ames, B.N., M.K Shigenaga, and T.M Hagen. 1993. Oxidants, antioxidants, and the degenerative diseases of aging. Proc Nat Acad Sci USA 90:7915-7922.
- Arai, Y., S. Wantanabe, M. Kimira, K. Shimoi, R. Mochizuki, and N. Kinae. 2000. Dietary intakes of flavonols, flavones, and isoflavones by Japanese women and the inverse correlation between quercetin intake and plasma LDL cholesterol concentration. Am Soc Nutr Sci 130(9):2243-2250.
- Arens, P., H. Coops, J. Jansen, and B. Vosman. 1998. Molecular genetic analysis of black poplar (*Populus nigra* L.) along Dutch rivers. Mol Eco 7:11-18.
- Becker, J., P. Vos, M. Kuiper, F. Salamini, M. Heun. 1995. Combined mapping of AFLP and RFLP markers in barley. Mol Gen Genet 249:65-73.
- Bhushan, B., and T. Thomas. 1990. Effects of  $\gamma$  irradiation and storage temperature on lipoxygenase activity and carotenoid disappearance in potato tubers (*Solanum tuberosum* L.). J Agric Food Chem 38:1586-1590.
- Bohm, V., N.L. Puspitasari-Nienaber, M.G. Ferruzzi, and S. J Schwartz. 2002. Trolox equivalent antioxidant capacity of different geometrical isomers of  $\alpha$ -carotene,  $\beta$ -carotene, Lycopene, and zeaxanthin. J Agric Food Chem 50:221-226.
- Bonierbale, M.W., R.L. Plaisted, and S.D. Tanksley. 1988. RFLP maps based on a common set of clones reveal modes of chromosomal evolution in potato and tomato. Genetics 120:1095-1103.

- Bowers, J.E., G.S. Dangl, R. Vignani, and C.P. Meredith. 1996. Isolation and characterization of new polymorphic simple sequence repeat loci in grape (*Vitis vinifera* L.). *Genome* 39:628-633.
- Brand-Williams, W., M.E. Cuvelier, and C. Berset. 1995. Use of free radical method to evaluate antioxidant activity. *Lebensm. Wiss. Technol.* 28:25-30.
- Breithaupt, D.E., and A. Bamedi. 2002. Carotenoids and carotenoid esters in potatoes (*Solanum tuberosum* L.): New insights into an ancient vegetable. *J Agric Food Chem* 50:7175-7181.
- Breyne, P., D. Rombaut, A. Van Gysel, M. Van Montagu, T. Gerats. 1999. AFLP analysis of genetic diversity within and between *Arabidopsis thaliana* ecotypes. *Mol Gen Genet* 261:627-634.
- Brown, C.R. 1993. Origin and history of the potato. *Am Potato J* 70:363-373.
- Brown, C.R., C.G. Edwards, C.P. Yang, and B.B. Dean. 1993a. Orange flesh trait in potato: Inheritance and carotenoid content. *J Amer Soc Hort Sci* 118:145-150.
- Brown, P.T.H., F.D. Lange, E. Kranz, and H. Lorz. 1993b. Analysis of single gene protoplasts and regenerated plants by PCR and RAPD technology. *Mol Gen Genet* 237:311-317.
- Brunstetter, B.C., and H.G. Wiseman. 1947. Carotenoid pigments in tubers of the Katahdin variety of Irish potatoes. *Plant Physiol* 22:421-437.
- Bureau, J.L., and R. Bushway. 1986. HPLC determination of carotenoids in fruits and vegetables in the United States. *Food Sci* 51(1):128-130.
- Bushway, R.J. and A.M. Wilson. 1982. Determination of alpha- and beta-carotene in fruits and vegetables by high performance liquid chromatography. *Can Inst Food Sci Technol. J* 15:165-169.
- Cabrita, L.F., U. Aksoy, S. Hepaksoy, and J.M. Leitao. 2001. Suitability of isozyme, RAPD, and AFLP markers to assess genetic differences and relatedness among fig (*Ficus carica* L.) clones. *Scientia Hort* 87:261-273.
- Caldwell, J.S., B.C. Brunstetter, C.W. Culpepper, and B.D. Ezell. 1945. Causes and control of discoloration in dehydration of white potatoes. *Canner* 100(13):35.
- Cao, G., E. Sofic, and R. Prior. 1997. Antioxidant and prooxidant behavior of flavonoids: Structure-activity relationships. *Free Radical Biol Med* 22(5):749-760.
- Cecchini, E., L. Natali, A. Cavallini, and M. Durante. 1992. DNA variations in regenerated plants of pea (*Pisum sativum* L.). *Theor Appl Genet* 84:874-879.

- Coffin, R., G.R. Johnston, A. McKeown, J. Wilson, M.K. Keenan, B. Langenberg, E. Knibbe, and L. Reynolds. 1988a. Rose Gold: A yellow-fleshed, pink-red skinned, tablestock cultivar with short dormancy and full season maturity. *Am Potato J* 65: 325-332.
- Coffin, R., G.R. Johnston, A. McKeown, T.R. Tarn, J. Wilson, M. Fitts, M.K. Keenan, L. Reynolds, and B. Langenburg. 1988b. Red Gold: A yellow-fleshed, red-skinned potato cultivar with short dormancy and high tuber set. *Am Potato J* 65:49-55.
- Corell, D.S. 1962. The potato and its wild relatives. Texas Research Foundation. Renner, Texas.
- Couillerot, J.P. 1993. Effects and distribution of C-gibberellic acid after application to stored potato microtubers. *Int J Exp Bot* 54(1):67-73.
- Crozier, A., M.E. J. Lean, M.S. McDonald, and M.S. Black. 1997. Quantitative analysis of the flavonoid content of commercial tomatoes, onions, lettuce, and celery. *J Agric Food Chem* 45:490-495.
- Dao, L., and M. Freidman. 1992. Chlorogenic acid content of fresh and processed potatoes determined by ultraviolet spectrophotometry. *J Agric Food Chem* 40:2152-2156.
- Demeke, T., L.M. Kawchuk, and D.R. Lynch. 1993. Identification of potato cultivars and clonal variants by random amplified polymorphic DNA analysis. *Am Potato J* 70:561-570.
- DeVerno, L.L., P.J. Charest, and L. Bonen. 1994. Mitochondrial DNA variation in somatic embryogenic cultures of *Larix*. *Theor Appl Genet* 88:727-732.
- Douches, D.S., and K. Ludlam. 1991. Electrophoretic characterization of North American potato cultivars. *Am Potato J* 68(11):767-780.
- Dreosti, I.E., M.J. Wargovich, and C.S. Yang. 1997. Inhibition of carcinogenesis by tea: The evidence from experimental studies. *Crit Rev Food Sci Nutr* 37:761-770.
- Duthie, G.G., S.J. Duthie, and J. A.M. Kyle. 2000. Plant polyphenols in cancer and heart disease: Implications as nutritional antioxidants. *Nutr Res Rev* 13:79-106.
- Escaravage, N., S. Questiau, A. Pornon, B. Doche, and P. Taberlet. 1998. Clonal diversity in a *Rhododendron ferrugineum* L. (Ericaceae) population inferred from AFLP markers. *Mol Eco* 7:975-982.
- Estabrook, W. 1988. New Brunswick potatoes: Past and present. New Brunswick Potato Agency. Centreville, New Brunswick.

- Fourre, J.L., P. Berger, L. Niquet, and P. Andre. 1997. Somatic embryogenesis and somoclonal variation in Norway spruce: morphogenetic, cytogenetic, and molecular approaches. *Theor Appl Genet* 94:159-169.
- Friedman, M. 1996. Nutritional value of proteins from different food sources. A review. *J Agric Food Chem* 44:6-29.
- Freidman, M. 1997. Chemistry, biochemistry, and dietary role of potato polyphenols. A review. *J Agric Food Chem* 45:1523-1540.
- Fritz, A.K., S. Caldwell, and W.D. Worall. 1999. Molecular mapping of Russian wheat aphid resistance from triticale accession PI 386156. *Crop Sci* 39:1707-1710.
- Fruwirth, C. 1912. Zur Zuchtung der Kartoffel. *Dtsch. Landw. Presse.* 39:551-552, 565-567.
- Fulton T, C. Juliapark, and S. Tanksley. 1995. Miniprep protocol for extraction of DNA from tomato and other herbaceous plants. *Mol Bio Rep* 13:207-209.
- Gazzani, G., A. Papetti, M. Daglia, F. Berte, and C. Gregotti. 1998. Protective activity of water soluble components of some common diet vegetables on rat liver microsome and the effect of thermal treatment. *J Agric Food Chem* 46:4123-4127.
- Giovannucci, E., A. Ascherio, E.B. Rimm, M.J. Stampfer, G.A. Colditz, and W.C. Willett. 1995. Intake of carotenoids and retinal in relation to risk of prostate cancer. *J Nat Cancer Inst* 87:1767-1776.
- Goulao, L., L. Monte-Carvo, and C. Oliveira. 2001. Plenetic characterization of plum cultivars by high multiplex ratio markers: Amplified fragment length polymorphisms and inter-simple sequence repeats. *J Am Soc Hort Sci* 126:72-77.
- Granado, F., B. Olmedilla, I. Blanco, and E. Rojas-Hidalgo. 1992. Carotenoid composition in raw and cooked Spanish vegetables. *J Agric Food Chem* 40:2135-2140.
- Gross, J. 1991. *Pigments in vegetables: Chlorophylls and carotenoids.* Van Nostrand Reinhold, New York.
- Guilford, P., S. Prakash, J.M. Zhu, E. Rikkerink, S. Gardiner, H. Bassett, and R. Forster. 1997. Microsatellites in *Malus x domestica* (apple): Abundance, polymorphism and cultivar identification. *Theor Appl Genet* 94:249-254.
- Hamouz, K., J. Lachman, B.Vokal, and V. Pivec. 1999a. Influence of environmental conditions and way of cultivation on the polyphenol and ascorbic acid content in potato tubers. *Rost Vyroba* 45(7):293-298.

- Hamouz, K., J. Lachman, B. Vokal, V. Pivee, and M. Orsak. 1999b. The effect of the conditions of cultivation on the content of polyphenol compounds in the potato varieties Agria and Karin. *Rost Vyroba* 43(11):541-546.
- Han, T.H., H. J. van Eck, M.J. De Jeu, and E. Jacobsen. 1999. Optimization of AFLP fingerprinting of organisms with a large-sized genome: A study on *Alstroemeria* spp. *Theor Appl Genet* 98:465-471.
- Hart, D.J., and K.J. Scott. 1995. Development and evaluation of an HPLC method for the analysis of carotenoids in foods, and the measurement of the carotenoid content of vegetables and fruits commonly consumed in the UK. *Food Chem* 54:101-111.
- Hashmi, G., R. Huettel, R. Meyer, L. Krusberg, and F. Hammerschlag. 1997. RAPD analysis of somoclonal variants derived from embryo callus cultures of peach. *Plant Cell Rep* 16:624-627.
- Haynes, K.G., W.E. Potts, J.L. Chittams, and D.L. Fleck. 1994. Determining yellow-flesh intensity in potatoes. *J Amer Soc Hort Sci* 119:1057-1059.
- Haynes, K.G., J.B. Sieczka, M.R. Henninger, and D.L. Fleck. 1996. Clone X environment -Interactions for yellow-flesh intensity in tetraploid potatoes. *J Amer Soc Hort Sci* 121:175-177.
- Haynes, K.G. 2000. Inheritance of yellow-flesh intensity in diploid potatoes. *J Amer Soc Hort Sci* 125(1):63-65.
- Heinonen, M.L., V. Ollilainen, E.K. Linkola, P.T. Varo, and P.E. Koivistoinen. 1989. Carotenoids in Finnish foods: Vegetables, fruits, and berries. *J Agric Food Chem* 37:655-659.
- Hermann, K. 1988. On the occurrence of flavone glycosides in vegetables. *Zeitschrift fur lebensmittel-untersuchung und-forschung*. 186:1-5.
- Hokanson, S.C., W.F. Lamboy, A.K. Szewe-McFadden, and J.R. McFerson. 2001. Microsatellite (SSR) variation in a collection of *Malus* (apple) species and hybrids. *Euphytica* 118:281-294.
- Hughes, D.A., J.A. Wright, P.M. Finglas, A.C. Polley, A.L. Bailey, S.B. Astley, and S. Southon. 2000. Effects of lycopene and lutein supplementation on the expression of functionally associated surface molecules on blood monocytes from healthy male nonsmokers. *J Infect Dis* 182:S11-S15.
- International Potato Center. 1984. Potatoes for the developing world. International Potato Center Lima, Peru.

- Isabel, N., L. Tremblay, M. Michaud, F.M. Tremblay, and J. Bousquet. 1993. RAPDs as an aid to evaluate the genetic integrity of somatic embryogenesis-derived populations of *Picea mariana* (Mill.) B.S.P. *Theor Appl Genet* 6:81-87.
- Iwanzik, W., M. Tevini, R. Stute, and R. Hilbert. 1983. Carotinoidgehalt und-Zusammensetzung verschiedener deutscher Kartoffelsorten und deren Bedeutung für die Fleischfarbe der Knolle. *Potato Res* 26:149-162.
- Janave, M.T., and P. Thomas. 1979. Influence of post-harvest storage temperature and gamma irradiation on potato carotenoids. *Potato Res* 22:365-369.
- Johansen, R.H., B. Farnsworth, D.C. Nelson, G.A. Secor, N. Gudmestad, and P.H. Orr. 1988. Russet Norkotah: A new russet-skinned potato cultivar with wide adaptation. *Am Potato J* 65:597-604.
- Johnston, G.R., and R.G. Rowberry. 1981. Yukon Gold: A new yellow-fleshed, medium-early, high quality table and French-fry cultivar. *Am Potato J* 58:241-244.
- Joseph, J.A., B. Shukitt-Hale, N.A. Denisova, R.L. Prior, G. Cao, A. Martin, G. Tagliabue, and P.C. Bickford. 1998. Long-term dietary strawberry, spinach, or vitamin E supplementation retards the onset of age-related neuronal signal-transduction and cognitive behavioral deficits. *J Neurosci* 18:8047-8055.
- Joseph, J.A., B. Shukitt-Hale, N.A. Denisova, D. Bielinski, A. Martin, J.J. McEwen, and P.C. Bickford. 1999. Reversals of age related declines in neuronal signal transduction, cognitive, and motor behavioral deficits with blueberry, spinach, or strawberry dietary supplementation. *J Neurosci* 19:8114-8121.
- Kalt, W., and M.M. Kushad. 2000. The role of oxidative stress and antioxidants in plant and human health? Introduction to the colloquium. *HortScience* 35:572.
- Kardolus, J., J. H. J. van Eck, R.G. van den Berg. 1998. The potential of AFLPs in biosystematics: A first application in *Sol* taxonomy (*Solanaceae*). *Plant System Evol* 210:87-103.
- Kasim, M. 1967a. Beitrag zur qualitativen analyse der carotinoide von kartofflen. *Tinode Nahrung* 11:411-415.
- Kasim, M. 1967b. Untersuchungen über die Zusammensetzung der Kartoffel-Carotoxine. *Toxicology* 23(1):21-48.
- Ke, D., and M.E. Saltveit, Jr. 1988. Plant hormone interaction and phenolic metabolism in the regulation of russet spotting in Iceberg lettuce. *Plant Physiol* 88:1136-1140.
- Khachik, F., G.R. Beecher, and C. Smith. 1995. Lutein, lycopene, and their oxidative metabolites in chemoprevention of cancer. *J Cell Biochem, Suppl* 22: 236-246.



- Khachik, F., J.S. Bertram, M.T. Huang, J.W. Fahey, and P. Talalay. 1999. Dietary carotenoids and their metabolites as potentially useful chemoprotective agents against cancer, p. 203-229. *In*: L. Packer, M. Hiramatsu, and T. Yoshikawa (eds.). *Antioxidant food supplements in human health*. Academic Press, San Diego.
- Kim, J.H., H. Joung, and Y.P. Lim. 1998a. Estimation of genetic variation and relationship in potato (*Solanum tuberosum*) cultivars using AFLP markers. *Am J Potato Res* 75:107-112.
- Kim, J.M., S. Araki, D.J. Kim, C.B. Park, N. Takasuka, H. Baba-Toriyama, T. Ota, Z. Nir, F. Khachik, N. Shimidzu, Y. Tanaka, T. Osawa, T. Uraji, M. Murakoshi, H. Nishino, and H. Tsuda. 1998b. Chemopreventive effects of carotenoids and curcumins on mouse colon carcinogenesis after 1,2-dimethylhydrazine initiation. *Carcinogenesis* 19(1):81-85.
- Kimura, M., and D.B. Rodriguez-Amaya. 2002. A scheme for obtaining standards and HPLC quantification of leafy vegetable carotenoids. *Food Chem* 78:389-398.
- Klein, P.E., R.R. Klein, S.W. Cartinhour, P.E. Ulanich, J. Dong, J.A. Obert, D.T. Morishige, S.D. Schlueter, K. L. Childs, M. Ale, and J.E. Mullet. 2000. A high-throughput AFLP-based method for constructing integrated genetic and physical maps: Progress toward a sorghum genome map. *Genome Res* 10:789-807.
- Kolasa, K. 1993. The potato and human nutrition. *Am Potato J* 70:375-384
- Kramling, T., and L. Singleton. 1969. An estimate of the nonflavonoid phenols in wines. *Am J Enol and Vitic* 20:86-92.
- Kuhnau, J. 1976. The flavonoids. A class of semi-essential food components: Their role in human nutrition. *World Rev of Nutr and Diet* 24:1117-1191.
- Lachman, J., K. Hamouz, M. Orsak, and V. Pivee. 2000. Potato tubers as a significant source of antioxidants in human nutrition. *Rost Vyroba* 46(5):231-236.
- Lamboy, W.F., and C.G. Alpha. 1998. Using simple sequence repeats (SSRs) for DNA fingerprinting germplasm accessions of grape (*Vitis* L.) species. *J Amer Soc Hort. Sci* 123:182-188.
- Lever, G., W.A. Trank, G. Shaver, J.C. Miller, Jr., and A.D. Pavlista. 1994. Norgold Russet, Superior and Red LaSoda strains selected for potato cultivar improvement in Nebraska. *Am Potato J* 71:133-143.
- Lewis, C.E., J.R.L. Walker, J.E. Lancaster, and K.H. Sutton. 1998a. Determination of anthocyanins, flavonoids and phenolic acids in potatoes. I. Coloured cultivars of *Solanum tuberosum* L. *J Sci Food Agric* 77:45-57.

- Lewis, C.E., J.R.L. Walker, J.E. Lancaster, and K.H. Sutton. 1998b. Determination of anthocyanins, flavonoids and phenolic acids in potatoes. II: Wild, tuberous *Solanum* species. *J Sci Food Agric* 77:58-63.
- Lewis, C.E., J.R.L. Walker, and J.E. Lancaster. 1999. Changes in anthocyanin, flavonoid, and phenolic acid concentrations during development and storage of coloured potato (*Solanum tuberosum* L.) tubers. *J Sci Food Agric* 79:311-316.
- Life Technologies. ND. Instruction manual: AFLP analysis system I. Life Technologies, Rockville, MD.
- Lopes, M.S., K.M. Sefc, E. Eiras Dias, H. Steinkellner, M. Laimer da Camara Machado, and A. da Camara Machado. 1999. The use of microsatellites for germplasm management in a Portuguese grapevine collection. *Theor Appl Genet* 99:733-739.
- Lu, W.H., K. Haynes, E. Wiley, and B. Clevidence. 2001. Carotenoid content and color in diploid potatoes. *J Am Soc Hort Sci* 126:722-726.
- Mandal, S., and G.D. Stoner. 1990. Inhibition of N-nitrosobenzylmethylamine-induced esophageal tumorigenesis in rats by ellagic acid. *Carcinogenesis* 11:55-61.
- McGregor, C.E., C.A. Lambert, M.M. Greyling, J.H. Louw, and L. Warnich. 2000. A comparative assessment of DNA fingerprinting techniques (RAPD, ISSR, AFLP, and SSR) in tetraploid potato (*Solanum tuberosum* L.) germplasm. *Euphytica* 113:135-144.
- McNeill, W.H. 1999. How the potato changed the world's history. *Soc Res* 66:67-83.
- Mejia, L.A., E. Hudson, E. Gonzalez de Mejia and F. Vasquez. 1988. Carotenoid content and vitamin A activity of some common cultivars of Mexican peppers (*Capsicum annum*) as determined by HPLC. *J Food Sci* 53(5):1448-1451.
- Meksem, K., D. Leister, J. Peleman, M. Zabeau, F. Salamini, and C. Gebhardt. 1995. A high-resolution map of the vicinity of the R1 locus on chromosome V of potato based on RFLP and AFLP markers. *Mol Gen Genet* 249:74-81.
- Menz, M.A., R.R. Klein, J.E. Mullet, J.A. Obert, N.C. Unruh, and P.E. Klein. 2002. A high-density genetic map of *Sorghum bicolor* (L.) Moench based on 2926 AFLP, RFLP, and SSR markers. *Plant Mol Biol* 48:483-499.
- Meyer, R.C., D. Milbourne, C.A. Hackett, J.E. Bradshaw, J.W. McNichol, and R. Waugh. 1998. Linkage analysis in tetraploid potato and association of markers with quantitative resistance to late blight (*Phytophthora infestans*). *Mol Gen Genet* 259:150-160.

- Milbourne, D., R. Meyer, J.E. Bradshaw, E. Baird, N. Bonar, J. Provan, W. Powell, and R. Waugh. 1997. Comparison of PCR-based marker systems for the analysis of genetic relationships in cultivated potato. *Mol Breed* 3:127-136.
- Milbourne, D., R.C. Meyer, A.J. Collins, L.D. Ramsay, C. Gebhardt, and R. Waugh. 1998. Isolation, characterization and mapping of simple sequence repeat loci in potato. *Mol Gen Genet* 259:233-245.
- Miller, N.J., J. Sampson, L.P. Candeias, P.M. Bramley, and C.A. Rice-Evans. 1996. Antioxidant activities of carotenes and xanthophylls. *FEBS Letters* 384:240-242.
- Miller, J.C. 1954. Selection of desirable somatic mutations: A means of potato improvement. *Am Potato J* 31:358-359.
- Miller, J.C., Jr., D. G. Smallwood, J.P. Miller and G.C.J. Fernandez. 1995. Norgold Russet and Norgold Russet M: Additional evidence for genetic dissimilarity. *Am Potato J* 72:273-286.
- Miller, J.C., Jr., D. C. Scheuring, J.P. Miller, and G.C.J. Fernandez. 1999. Selection, evaluation, and identification of improved Russet Norkotah strains. *Am J Potato Res* 76:161-167.
- Minguez-Mosquera, M.I., and D. Hornero-Mendez. 1993. Separation and quantification of the carotenoid pigments in red peppers (*Capsicum annum* L.), paprika and oleoresin by reverse-phase HPLC. *J Agric Food Chem* 4:1616-1620.
- Moline, J., I.F. Bukharovich, M.S. Wolff, and R. Phillips. 2000. Dietary flavonoids and hypertension: Is there a link? *Med Hypoth* 55(4):306-309.
- Monte-Corvo, L., L. Goulao, and C. Oliveira. 2001. ISSR analysis of cultivars of pear and suitability of molecular markers for clone discrimination. *J Amer Soc Hort Sci* 126:517-522.
- Muller, E., P.T.H. Brown, S. Hartke, and H. Lorz. 1990. DNA variation in tissue-culture-derived rice plants. *Theor Appl Genet* 80:673-679.
- Narisawa, T., Y. Fukaura, M. Hasebe, M. Ito, R. Aizawa, M. Murkakoshi, S. Uemura, F. Khachik, and H. Nishino. 1996. Inhibitory effects of natural carotenoids,  $\alpha$ -carotene,  $\beta$ -carotene, lycopene and lutein, on colonic aberrant crypt foci formation in rats. *Cancer Letters* 107:137-142.
- National Potato Council. 1998. Potato statistical yearbook. National Potato Council, Greenwood Village, CO.
- National Potato Council. 1999. Potato statistical yearbook. National Potato Council, Greenwood Village, CO.

- National Potato Council. 2002. Potato statistical yearbook. National Potato Council, Greenwood Village, CO.
- National Potato Council. 2003. Potato statistical yearbook. National Potato Council, Washington DC.
- Niederhauser, J.S. 1993. Internation cooperation and the role of the potato in feeding the world. *Am Potato J* 70:385-405.
- Nishino, H. 1995. Cancer chemoprevention by natural carotenoids and their related compounds. *J Cellular Biochem.* 22:231-235.
- North American Blueberry Council. 2003. North American Blueberry Council. <http://www.blueberry.org>.
- Pateau, I., F. Khachik, E.D. Brown, G.R. Beecher, T.R. Kramer, J. Chittams, and B.A. Clevidence. 1998. Chronic ingestion of lycopene-rich tomato juice or lycopene supplements significantly increases plasma concentrations of lycopene and related tomato carotenoids in humans. *Am J Clin Nutr* 68:1187-1195.
- Pendlington, S., M.S. Dupont, and F. J. Trussell. 1965. The carotenoid pigments of *Solanum tuberosum*. *Biochem J* 94:25-26.
- Perez-Galvez, A., and M. I Minguez-Mosquera. 2002. Degradation of non-esterified and esterified xanthophylls by free radicals. *Biochimica et Biophysica Acta* 1569:31-34.
- Peterson, J., and J. Dwyer. 1988. Flavonoids: Dietary occurrence and biochemical activity. *Nutr Res* 18:2363-2366.
- Pornon, A., N. Escaravage, P. Thomas, and P. Taberlet. 2000. Dynamics of genotypic structure in clonal *Rhododendron ferrugineum* (Ericaceae) populations. *Mol Ecol* 9:1099-1111.
- Prior, R.L., G. Cao, A. Martin, E. Sofic, J. McEwen, C. O'Brien, N. Lischner, M. Ehlenfeldt, W. Kalt, G. Krewer, and C.M. Mainland. 1998. Antioxidant capacity as influenced by total phenolic and anthocyanin content, maturity, and variety of *Vaccinium* species. *J Agric Food Chem* 46:2686-2693.
- Provan, J., W. Powell, and R. Waugh. 1996. Microsatellite analysis of relationships within cultivated potato (*Solanum tuberosum*). *Theor Appl Genet* 92:1078-1084.
- Raker, C., and D.M. Spooner. 2002. The Chilean tetraploid cultivated potato, *Solanum tuberosum*, is distinct from the Andean populations; microsatellite data. *Crop Sci* 45:1451-1458.

- Reeve, R.M., E. Hautala, and M.L. Weaver. 1969. Anatomy and compositional variation within potatoes II. Phenolics, enzymes, and other minor components. *Am Potato J* 46:374-386.
- Regner, F., A. Stadlbauer, C. Eisenheld, and H. Kaserer. 2000. Genetic relationships among pinots and related cultivars. *Am J Enol Vitic* 51(1):7-14
- Robards, K., and Antolovich, M. 1997. Analytical chemistry of fruit and bioflavonoids. *Analyst* 122:R11-R34.
- Rodriguez de Sotillo, D., M. Hadley, and E.T. Holm. 1994. Phenolics in aqueous potato peel extract: Extraction, identification, and degradation. *J Food Sci* 59:649-651.
- Rodriguez de Sotillo, D., H. Hadley, and C. Wolf-Hall. 1998. Potato peel extract a non mutagenic antioxidant with potential antimicrobial activity. *J Food Sci* 63:907-910.
- Russell, J., J. Fuller, G. Young, B. Thomas, G. Taramino, M. Macaulay, R. Waugh, and W. Powell. 1997. Discriminating between barley genotypes using microsatellite markers. *Genome* 40:442-450.
- Sabir, A., H.J. Newbury, G. Todd, J. Catty, and B.V. Ford-Lloyd. 1992. Determination of genetic stability using isozymes and RFLPs in beet plants regenerated in vitro. *Theor Appl Genet* 84:113-117.
- Sambrook, J., E.F. Fritsch, and T. Maniatis. 1989. *Molecular cloning: A laboratory manual*, 2<sup>nd</sup> Ed. Cold Spring Harbor Laboratory Press, New York.
- Schneider, K., and D. Douches. 1997. Assessment of PCR-based simple sequence repeats to fingerprint North American potato cultivars. *Am Potato J* 74:149-160.
- Scott, K.J., P.M. Finglas, R. Seale, D.J. Hart, and I. De Froidmont-Gortz. 1996. Interlaboratory studies of HPLC procedures for the analysis of carotenoids in foods. *Food Chem* 57(1):85-90.
- Scott, K.J. 2001. Detection and measurements of carotenoids by UV/VIS spectrophotometry, p. F2.2.1-F2.2.10. *In: Current protocols in food analytical chemistry*. John Wiley and Sons, Inc, New York.
- Seddon, J.M., U.A. Anani, R. D. Sperduto, R. Hiller, N. Blair, T.C. Burton, M.D. Farber, E.S. Gragoudas, J. Haller, D.T. Miller, L. A. Yannuzzi, and W. Willett. 1994. Dietary carotenoids, vitamins A, C, and E, and advanced age-related macular degeneration. *JAMA* 272:1413-1420.
- Sefc, K.M., M.S. Lopes, F. Lefort, R. Botta, K.A. Roubelakis-Angelakis, J. Ibanez, I. Pejic, H.W. Wagner, J. Glossl, and H. Steinkellner. 2000. Microsatellite variability

- in grapevine cultivars from different European regions and evaluation of assignment testing to assess the geographic origin of cultivars. *Theor Appl Genet* 100:498-505.
- Smith, M J., P.F. Insera, R.R. Watson, J.A. Wise, and K.L O'Neill. 1999. Supplementation with fruit and vegetable extracts may decrease DNA damage in the peripheral lymphocytes of an elderly population. *Nutrition Research* 19:1507-1518.
- Somerville, C., and S. Somerville. 1999. Plant functional genomics. *Science* 285:380-383.
- Sosinski, B., and D.S. Douches. 1996. Using polymerase chain reaction-based DNA amplification to fingerprint North American potato cultivars. *HortScience* 31:130-133.
- Stagg, G.V., and D.J. Millin. 1975. The nutritional and therapeutic value of tea – A review. *J Sci Food Agric* 26: 1439-1459.
- Stoner, G.D., and H. Mukhtar. 1995. Polyphenols as cancer chemopreventive agents. *J Cell Biochem, Suppl* 22:169-180.
- Struss, D., and J. Plieske. 1998. The use of microsatellite markers for detection of genetic diversity in barley populations. *Theor Appl Genet* 97:308-315.
- Terao, J. 1989. Antioxidant activity of Beta-carotene-related carotenoids in solution. *Lipids* 24: 659-661.
- Tevini, M., W. Iwanzik, and G. Schonecker. 1984. Analyse vorkommen und nerhalten von carotinoiden in kartoffeln und kartoffelprodukten. *Jahrbuch Forschungskreis Ernahrungsindustrie e V* 5:36-53.
- Tevini, M., and G. Schonecker. 1986. Occurrence, properties, and characterization of potato carotenoids. *Potato Res* 29(2):265.
- Thomas, P., and M.R. Joshi. 1977. Prevention of after-cooking darkening of irradiated potatoes. *Potato Res* 20:77-84.
- Thompson, L.U. 1994. Antioxidants and hormone-mediated health benefits of whole grains. *Crit Rev Food Sci Nutr* 34(5&6):473-497.
- Van Der Hulst, R.G.M., T.H.M. Mes, J.C.M. Den Nijs, and K. Bachmann. 2000. Amplified fragment length polymorphism (AFLP) markers reveal that population structure of triploid dandelions (*Taraxacum officinale*) exhibits both clonality and recombination. *Mol Ecol* 9:1-8.
- Vignani, R., J.E. Bowers, and C.P Meredith. 1996. Microsatellite DNA polymorphism analysis of clones of *Vitis vinifera* 'Sangiovese'. *Sci Hort* 65:163-169.

- Vos, P., R. Hres, M. Bleeker, M. Reijans, T. van de Lee, M. Hornes, A. Frijters, J. Pot, J. Peleman, M. Kuiper, and M. Zabeau. 1995. AFLP: A new technique for DNA fingerprinting. *Nuc Acids Res* 23:4407-4414.
- Wagner, A.V., G. D. Kochert, D. Sparks, and H. Y. Wetzstein. 2000. Field performance and molecular evaluations of pecan trees regenerated from somatic embryogenic lines. *J Amer Soc Hort Sci* 125:542-546.
- Wargovich, M.J. 2000. Anticancer properties of fruits and vegetables. *HortScience* 35:573-575.
- Wattenberg, L.W. 1992. Inhibition of carcinogenesis by minor dietary constituents. *Cancer Res (Suppl.)* 52:2085s-2091s.
- Weisburger, J. H. 2000. Eat to live, not live to eat. *Nutrition* 16:767-773.
- Willett, W. 1994. Diet and health: What should we eat? *Science, New series* 264:532-537.
- Windfield, M.O., G.M. Arnold, F. Cooper, M LeRay, J. White, A. Karp, and K.J. Edwards. 1998. A study of genetic diversity in *Populus nigra* subsp. *Betulifolia* in the Upper Severn area of the UK using AFLP markers. *Mol Ecol* 7:3-10.
- Yamamoto, I., K. Takano, H. Sato, I. Kamoi, and T. Miamoto. 1997. Natural toxic substances polyphenols, limolene, and allyl isothiocyanate in several edible crops. *Tokyo Nogyo Daigaku Nogaku Shuho* 41:239-245.
- Zuckerman, L. 1998. The potato: How the humble spud rescued the western world. Faber and Faber, Inc., Winchester MA.
- Zvomuya, F., C.J. Rosen, and J.C. Miller, Jr., 2002. Response of Russet Norkotah clonal selections to nitrogen fertilization. *Am J Potato Res* 79:231-239.

## **APPENDICES**



## APPENDIX A

### PROTOCOL FOR DNA EXTRACTION – MINIPREP PROCEDURE

#### **BUFFERS:**

##### *Extraction Buffer – 20L*

.35M Sorbitol	1275g
0.1M Tris-base	242g
0.005M EDTA	33.6g

Adjust pH to 7.5 with HCL  
Add Na-Bisulfate (0.02M=3.8g/L) just before use

##### *Nuclei Lysis Buffer:*

	[Final]
200ml 1M Tris	0.2M
200ml 0.25M EDTA	0.05M
400ml 5.0M NaCl	2M
20g CTAB	2% w/v
200ml of dH <sub>2</sub> O	

1. Harvest leaf tissue
  - a. Harvest approximately 3g young leaf tissue and freeze at –80 C as soon as possible
2. Freeze leaf tissue
  - a. Immerse samples in liquid nitrogen
  - b. Grind to a fine powder
  - c. Transfer leaf powder to 50ml screw cap centrifuge tubes and place each tube at –20 C until all samples have been ground.
  - d. Leave caps off and cover rack with handi-wrap and rubber band.
  - e. Store at –80 C until ready to use.
3. Homogenize tissue
  - a. Add Na-Bisulfate to extraction buffer just before use (3.8g/L). For 16 samples, use 2.28g in 600ml. Keep on ice.
  - b. Add 20-25ml cold extraction buffer to frozen leaf sample one sample at a time. Leave other samples at –20 C until ready for extraction.
  - c. Homogenize sample for 5-10 seconds using a polytron at room temperature
  - d. Set tube on ice and repeat for other samples. Do not cap tubes.
4. Centrifuge samples in Beckman TJ-6 table-top centrifuge at full speed for 20 minutes.

5. Carefully pour off supernatant, including loose green material.
  - a. Add 1.25ml of extraction buffer to the pellet, and vortex full speed for 5 seconds
  - b. Add 1.75ml nuclear lysis buffer and 0.6ml 5% Sarkosyl
  - c. Cap tubes and invert 5-10 times.
  - d. Incubate at 65 C for 20 minutes
  
6. Add 7.5ml chloroform/isoamyl alcohol (24:1)
  - a. Cap the tubes and place on an orbital shaker for 20-30 minutes.
  - b. Centrifuge (Beckman TJ-6) at full speed for 15-20 minutes
  - c. Carefully pipet off aqueous supernatant into pre-labeled 15ml Falcon tubes. Do not allow any of the interphase to be drawn up.
  
7. Precipitate DNA by adding 4ml of cold isopropanol and carefully invert the tubes 5-10 times
  
8. Most samples should form a precipitate of DNA which can be hooked out.
  - a. Dry the DNA on a Kimwipe
  - b. Resuspend it in 100-300ul TE for 10 minutes at 65 C.
  - c. Spin down starch and residual plant material in table top centrifuge at a setting of "5" for 10 minutes.
  - d. Store at 4 C if DNA will be used soon or at -20 C if DNA is to be stored for an extended period

## APPENDIX B

### *EcoRI AND MseI RESTRICTION DIGESTION AND ADAPTER*

#### LIGATION

*Used for Silver Staining Protocol for AFLP  
Taken and modified from GIBCO BRL Manual*

#### Restriction Digestion

5X Reaction Buffer	1.25ul
<i>EcoRI/MseI</i>	0.50ul
DdH <sub>2</sub> O	0.50ul
DNA (50ng/ul)	4.0ul

Incubate at 37 C for 2 hours

Heat inactivate at 70 C for 15 minutes

#### Adapter Ligation

Adapter Ligation Solution	6.0ul
T4 DNA ligase	.25ul
Restricted DNA	6.25ul

Mix gently at room temperature and incubate on the bench overnight.

Taking 6.25ul from the Restriction x Adapter mix, and add 9.25ul of TE (supplied with the kit). The total volume now becomes 15.5

#### Restricted Adapter ligated Diluted DNA (RAD)

Restriction x Adapter mix	6.25ul
TE (From kit)	9.25ul
Total	15.5ul

## APPENDIX C

### PREAMPLIFICATION FOR AFLP

*EcoRI/ MseI – AFLP for Silver Staining*  
*Modified from Genco BRL Manual*

---

#### Preamplification

Template DNA (RAD)	1.25ul
Pre-Amp Primer Mix	10.0ul
10X PCR buffer for AFLP	1.25ul
Taq DNA Polymerase (Gibco)	0.05ul
DdH <sub>2</sub> O	0.20ul

#### PCR Profile

94 C for 30 seconds		20 cycles
56 C for 1 minute		
72 C for 1 minute		

Dilute Pre-Amp DNA 1:10. This becomes the Template for Selective Amplification

PreAmp PCR product	10ul
TE	90ul

## APPENDIX D

### SELECTIVE AMPLIFICATION FOR AFLP

*EcoRI/ MseI – AFLP for Silver Staining*  
*Modified from Gbco BRL Manual*

---

#### Selective Amplification

##### Mix 1

<i>EcoRI</i> Primer	0.25ul
<i>MseI</i> Primer (contains dNTPs)	2.25ul
Total	2.50ul

##### Mix 2

ddH <sub>2</sub> O	3.95ul
10X PCR Buffer for AFLP	1.00ul
Taq DNAP (5u/ul Gibco)	0.05ul
Total	5.00ul

##### Final Reaction

Mix 2	5.00ul
Diluted Template DNA (TSA)	2.50ul
Mix 1	2.50ul
Total	10.0ul

#### PCR Profile

1. Perform 1 cycle at:
  - a. 94 C for 30 seconds
  - b. 65 C for 30 seconds
  - c. 72 C for 60 seconds
2. Lower the annealing temperature each cycle 0.7 C during 12 cycles. This gives a touch down phase of 13 cycles
3. Perform 23 cycles at:
  - a. 94 C for 30 seconds
  - b. 56 C for 30 seconds
  - c. 72 C for 60 seconds
4. Total time is 2 hours 2 minutes

#### **After PCR:**

Dry in a speed vac at medium speed until dry (~30 minutes).  
 Resuspend with ½ water and ½ dye (5ul water, 5ul dye)

**APPENDIX E****FORMAMIDE MANUAL SEQUENCING DYE***Sambrook et al., 1989*

---

**Dye:**

Formamide	10ml
Xylene Cyanol FF	10ml
Bromophenol Blue	10mg
0.5M EDTA pH8	200ul

## APPENDIX F

### SILVER STAINING SEQUENCING GELS

*Fritz et al., 1999*

#### GEL SOLUTIONS

##### **Bind Silane**

Absolute Ethanol	995ml
Glacial Acetic Acid	5ml
Bind Silane ( $\gamma$ -methacryloxypropyltrimethoxysilane)	0.5ul

##### **Sodium Thiosulfate**

10mg/ml in ddH<sub>2</sub>O

Store in small snap-cap tubes and make in small aliquots

##### **Fix/Stop Solution**

Glacial Acetic Acid	200ml
ddH <sub>2</sub> O	800ml

##### **Staining Solution**

Silver Nitrate (AgNO <sub>3</sub> )	2g
37% Formaldehyde	3ml
ddH <sub>2</sub> O	to approximately 2L

Store in glass container in the dark. Can be used 5-10 times

##### **Developer**

Na <sub>2</sub> CO <sub>3</sub>	60g
DdH <sub>2</sub> O	2L

Chill prior to use:

Immediately prior to use add:

400ul sodium thiosulfate (10mg/ml)

3ml 37% formaldehyde

##### **2% NaOH**

NaOH	40g
DdH <sub>2</sub> O	2L

1. Preparation of glass plates:
  - a. For best results, new plates should be soaked approximately 1 hour in 2M NaOH before use. Wash plates thoroughly after usage. After washing, use acetone and a Kimwipe or paper towel to clean the short plate (2-3 times). This removes any excess bind silane from the previous use.
  - b. Rinse well with water.
  - c. Spray with 100% ethanol and use squeegee to remove the excess. Wipe dry with a Kimwipe.
  - d. Apply Rain-X to the large glass plate and use chem. wipe to distribute onto the plate. Use a clean Kimwipe and continue wiping the plate until all of the Rain-X is absorbed or evaporated.
  - e. Rinse with absolute ethanol.
  - f. Clean short plate with acetone, water, and ethanol.
  - g. Apply approximately 3-4ml of bind silane to the short glass plate, and using parafilm, spread the solution over the surface until the plate is coated and the solution has evaporated. Let the plate dry.
  - h. Rinse with absolute ethanol and dry with a kimwipe or a paper towel.
  - i. Place treated plates together.
2. Proceed with gel preparation and electrophoresis.
3. Separate glass plates using a small spatula following electrophoresis. The gel will remain attached to the short plate.
4. Place the short plate, with the gel attached, in a container with Fix/Stop solution (10% Acetic Acid), and agitate gently until dye band disappears (~15 minutes)
5. Remove the plate and drain the excess solution. Save the Fix/Stop.
6. Place the gel in a container with ddH<sub>2</sub>O and gently agitate for 6 minutes.
7. Remove plate and drain the excess water.
8. Place the gel in a container with the stain solution for 10 minutes under gentle agitation.
9. Add 400ul Sodium Thiosulfate and 3ml formaldehyde to 2L of ice-cold developing solution.
10. Gently and briefly (~10 seconds) rinse gel in water and then transfer to ice-cold developing solution.
11. Allow the gel to develop by providing gently agitation until the bands are visible (~3 minutes).
12. When the bands are visible, remove the gel from developer and drain.
13. Place the gel in the Fix/Stop solution to stop the reaction. Gently agitate for 2-3 minutes.
14. Rinse for 2 minutes in water under gentle agitation.
15. Place the plate in a tray with 2%NaOH for 2-10 minutes and gently agitate. The gel should not float away, but the edges should begin to loosen from the plate.
16. Lift plate from the solution and place it carefully in a tray with ~30% Fix/Stop. Soak the gel without agitation for 3 minutes.
17. Transfer to Whatman 3MM paper and dry overnight on the lab bench.



## APPENDIX G

### DENATURING POLYACRYLAMIDE GELS

---

---

#### **6% Denaturing Polyacrylamide Gel**

Urea	12.6g
ddH <sub>2</sub> O	7.5ml
PagePlus polyacrylamide	4.9ml
10X TBE	3.6ml

Bring volume to 30ml.

Filter and degas in sterilizing unit.

Then add:

APS (10%)	200ul
TMED	20ul

Immediately pour between two glass sequencing plates and allow the gel to polymerize for 2-3 hours.

#### **7% Denaturing Polyacrylamide Gel**

Urea	12.6g
ddH <sub>2</sub> O	7.5ml
PagePlus polyacrylamide	5.7ml
10X TBE	3.6ml

Bring volume to 30ml.

Filter and degas in sterilizing unit.

Then add:

APS (10%)	200ul
TMED	20ul

Immediately pour between two glass sequencing plates and allow the gel to polymerize for 2-3 hours.

**APPENDIX H**

**RESTRICTION DIGESTION OF GENOMIC DNA WITH *ECORI***

**AND *MSEI* FOR LI-COR ANALYSIS**

*Menz et al., 2002*

---

Dilute the DNA to be digested to a concentration of 100ng/ul, and aliquot 5ul of each genotype into .5ul microcentrifuge tubes. 500ng of genomic DNA will be used for each reaction.

**MseI Digestion**

10X NE Buffer 2	5.0ul
10mg/ml BSA	0.5ul
4 U/ul <i>MseI</i> (New England Biolabs)	0.625ul
ddH <sub>2</sub> O	36.275ul
Total	37.375ul

- Add to 500ng of genomic DNA.
- Mix gently by tapping.
- Incubate at 37°C for 2 hours.
- Heat inactivate at 65°C for 20 minutes.

***PstI* Digestion**

5M NaCl	0.5ul
1M Tris HCL pH 7.9	2.0ul
20 U/ul <i>PstI</i>	0.125ul
Total	2.625

- After *MseI* digestion, add 2.625ul to each tube.
- Mix by tapping.
- Incubate at 37 C for 2 hours.
- Heat inactivate at 65 C for 20 minutes.
- Spin down and place on ice.

## APPENDIX I

### ADAPTER LIGATION

*MseI/PstI for use with LI-COR system*

---

#### Adapter Ligation Mix

10X Ligation Buffer	1ul
50pmol/ul <i>MseI</i> adapter	1ul
5pmol/ul <i>PstI</i> adapter	1ul
T4 DNA Ligase	1ul
DdH <sub>2</sub> O	6ul

Incubate at 37 C overnight.

Add 440ul H<sub>2</sub>O to dilute.

Resulting mixture is termed Restricted Aadapter-ligated diluted DNA (RAD).

## APPENDIX J

### PREAMPLIFICATION REACTION

*MseI/PstI for use with LI-COR system*  
*Klein, et al., 2000.*

#### Preamplification Reaction

10X PCR Buffer	2.5ul
50mM MgCl <sub>2</sub>	0.75ul
2.0mM dNTPs	2.0ul
10pmol/ul P-C-pre-amp primer	1.4ul
10pmol/ul M-C pre-amp primer	1.4ul
Taq DNAp (Promega)	0.2ul
ddH <sub>2</sub> O	11.75ul
Total	20.0ul

- Add to 5ul of RAD DNA.
- Mix reactions well by drawing up and down 8-10 times with pipettor.

#### PCR Profile (20ul rxn)

25 cycles of:  
 94 C for 30 seconds  
 56 C for 1 minute  
 72 C for 1 minute  
 Final hold at 4°C

Dilute 1:10 with H<sub>2</sub>O (1ul pre-amp DNA:9ul H<sub>2</sub>O).  
 Make 1% agarose gel to test whether preamplification was successful.

## APPENDIX K

### SELECTIVE AMPLIFICATION REACTION

*MseI/PstI for use with LI-COR system  
Klein, et al., 2000.*

#### Preamplification Reaction

10X PCR Buffer	1.00ul
25mM MgCl <sub>2</sub>	0.50ul
2.0mM dNTPs	1.0ul
~1uM Pst Selective Primer (+3)	.15ul
7.5ng/ul Mse selective primer (+3)	0.5ul
Taq DNAP (Promega)	0.04ul
ddH <sub>2</sub> O	4.81ul
Total	8.0ul

- Add to 2ul of TSA (Template for Selective Amplification).
- Mix reactions well by drawing up and down 8-10 times with pipettor.
- Since the p-primer is light sensitive, add it to the mixture last, and keep the reaction in the dark.

#### PCR Profile (20ul rxn)

95 C for 2 minutes		13 cycles	
94 C for 1 second			— reduce annealing temperature by 0.6°C/cycle
65 C for 1 minute (-.6°C/cycle)			
72 C for 1 minute 30 seconds			
94 C for 30 seconds		23 Cycles	
56 C for 30 seconds			
72 C for 1 minute			
72 C for 5 minutes			
4 C for ever			

## APPENDIX L

### ORIENTING SAMPLES AND BASIC FUSION LOADING DYE

#### *MseI/PstI for use with LI-COR system*

#### **Orientation of PCR plates:**

To allow loading with a Hamilton 8-channel syringe, PCR plates were set up in the following orientation. The letters across the top are the column number, and the numbers down the left hand side are the row numbers of the PCR plate. Numbers on a white background are the sample/well numbers.

	A	B	C	D	E	F	G	H
1	1	5	9	13	17	21	25	29
2	2	6	10	14	18	22	26	30
3	3	7	11	15	19	23	27	31
4	4	8	12	16	20	24	28	32
5	33	37	41	45	49	53	57	61
6	34	38	42	46	50	54	58	62
7	35	39	43	47	51	55	59	63
8	36	40	44	48	52	56	60	64
9	65	69	73	77	81	85	89	93
10	66	70	74	78	82	86	90	94
11	67	71	75	79	83	87	91	95
12	68	72	76	80	84	88	92	96

#### **Basic Fusion Loading Dye**

Basic Fusion Loading Dye	200ul
10X PCR Buffer	100ul

**APPENDIX M****LONGRANGE POLYACRYLAMIDE GELS***MseI/PstI for use with LI-COR system*

---

---

**6% Denaturing Polyacrylamide Gel with 7M Urea**

Urea	12.6g
ddH <sub>2</sub> O	7.5ml
LongRanger polyacrylamide	4.9ml
10X TBE	3.6ml

Bring volume to 30ml.

Filter and degas in sterilizing unit.

Then add:

APS (10%)	200ul
TMED	20ul

Immediately pour between two glass sequencing plates and allow the gel to polymerize overnight.

**7% Denaturing Polyacrylamide Gel with 7M Urea**

Urea	12.6g
ddH <sub>2</sub> O	7.5ml
LongRanger polyacrylamide	5.7ml
10X TBE	3.6ml

Bring volume to 30ml.

Filter and degas in sterilizing unit.

Then add:

APS (10%)	200ul
TMED	20ul

Immediately pour between two glass sequencing plates and allow the gel to polymerize overnight.

## APPENDIX N

### MICROSATELLITE AMPLIFICATION

*Raker and Spooner (2002)*

#### Microsatellite Amplification Reaction

10X PCR Buffer	2.50ul
25mM MgCl <sub>2</sub>	1.50ul
2.5mM dNTPs	2.00ul
10uM forward primer	1.00ul
10uM reverse primer	1.00ul
Taq DNAP (Sigma 1u/ul)	1.00ul
ddH <sub>2</sub> O	12.00ul
5ng/ul genomic DNA	4.00ul
Total	25.00ul

#### PCR Profile (25ul rxn)

94 C for 10 minutes		1 cycle
[Tm] °C for 2 minutes		
72 C for 5 minutes		
94 C for 1 minute		29 Cycles
[Tm] C for 45 seconds		
72 C for 5 minutes		
72 C for 45 minutes		
4 C for ever		



**APPENDIX O**

**PROTOCOL FOR ANALYZING ANTIOXIDANT ACTIVITY IN**

**POTATO USING DPPH**

---

---

1. Dice the entire potato into  $\frac{1}{4}$  inch cubes and take a random sample from each potato.
2. Weighing the sample
  - a. Weigh 5 g of diced potato sample (in triplicate).
  - b. Use different tubers for each replicate.
3. The Extraction
  - a. Add 15 ml of methanol to the 5 g of sample.
  - b. Homogenize for 3-4 minutes
  - c. Centrifuge for 20 minutes at 16,000 rpm
  - d. Save 1.5 ml of supernatant for assay
4. The Assay
  - a. Prepare a 607  $\mu$ M DPPH solution by dissolving 24 mg DPPH in 100 ml of methanol.
  - b. Dilute the stock solution ~10:55 with methanol until the spectrophotometer reads 1.1 at 515nm.
  - c. Add 2850  $\mu$ l of diluted DPPH to 150  $\mu$ l of extract in a scintillation vial
  - d. Shake for 15 minutes.
  - e. Determine absorption at 515 nm on a spectrophotometer
  - f. Note: It's best not to analyze more than 12 samples at a time.
5. Prepare a standard curve of a known antioxidant using known concentrations.
6. Use the regression equation to convert antioxidant activity into equivalents of known antioxidants

## APPENDIX P

### INSTRUMENT METHOD FOR PHENOLIC SEPARATION

---

**Name:** Larry's Suggestion 2  
**Column:** Atlantis  
 4.6 x 150 mm, 5 $\mu$ m  
**Solvent A:** Water adjusted with HCL to a pH of 2.3  
**Solvent B:** Acetonitrile  
**Temperature:** 40C  
**Run Time:** 47 minutes

#### Gradient

	<b>Time</b>	<b>Flow</b>	<b>%A</b>	<b>%B</b>	<b>Curve</b>
1		1	85	15	
2	5	1	85	15	6
3	30	1	0	100	6
4	35	1	0	100	6
5	36	1	85	15	6
6	100	1	85	15	6
7	101	0	85	15	11

- Steps 1-3 are the gradient on which the samples were run.
- Steps 3-4 are a column clean which was run between each injection.
- Steps 4-6 brought the column back to initial conditions for the succeeding injection.
- Steps 6-7 are automatic shutdown steps for the HPLC system.

## APPENDIX Q

### INSTRUMENT METHOD FOR CAROTENOID SEPARATION

*Breithaupt and Bamedi (2002)*

---

**Name:** Carotenoid  
**Column:** YMC Carotenoid Column  
 4.6 x 250 mm, 5 $\mu$ m  
**Solvent A:** Methanol/water/triethylamine (90:10:0.1 v/v/v)  
**Solvent B:** Methanol/MTBE/triethylamine (6:90:0.1v/v/v)  
**Temperature:** 35C  
**Run Time:** 73 minutes

#### Gradient

	Time	Flow	%A	%B	Curve
1		1	99	1	
2	8	1	99	1	6
3	45	1	0	100	6
4	50	1	0	100	6
5	53	1	99	1	6
6	73	1	99	1	6
7	100	1	99	1	6
8	101	0	99	1	11

- Steps 1-3 are the gradient on which the samples were run.
- Steps 3-4 are a column clean which was run between each injection.
- Steps 4-6 brought the column back to initial conditions for the succeeding injection.
- Steps 6-8 are automatic shutdown steps for the HPLC system.

**VITA**  
**Anna Louise Hale**

**Work Address**

Department of Horticultural Sciences  
Texas A&M University  
College Station, TX 77843-2133  
(979) 845-0135

**Permanent Address**

1524 Orchid  
McAllen, TX 78504  
(956) 682-4088

---

**Education:**

Texas A&M University	Texas A&M University
<i>Department of Horticultural Sciences</i>	B.S. in Genetics 1997
Ph.D. in Genetics 2003	

**Awards and Honors**

**Tom Slick Fellowship.** Awarded by the College of Agriculture, Texas A&M University, to outstanding Ph.D. students in the College of Agriculture and Life Sciences, 2002.

**National Potato Council Auxiliary Scholarship:** Awarded by the National Potato Council Auxiliary to selected graduate students conducting their dissertation research on potatoes, 2001.

**Publications**

- Hale, A.L., D.C. Scheuring, T.J. Gerik, J.D. Hart, and J.C. Miller, Jr. 2000. Further investigations on the genetics of resistance to iron deficiency in cowpea. *HortScience* 35:560. (Abstr).
- Hale, A.L., J.C. Miller, Jr., J.P. Miller, and R.D. Lineberger. 2000. The PAA Web Site - Goodbye Texas, Hello Maine. *Amer. J. Potato Res.* 77:400-401. (Abstr.).
- Hale, A.L., L. Cisneros-Zevallos, J.B. Bamberg, and J.C. Miller, Jr. 2001. Identification of named varieties, advanced selections and accessions with high antioxidant activity for use in breeding potatoes for enhanced human health benefits. *Am. J. Potato Res.* 78(6):455-456. (Abstr.).
- Warrington, R.T, A.L Hale, D.C. Scheuring, D. W. Whitaker, T. Blessington, and J.C. Miller, Jr. 2002. Variability of antioxidant activity in cowpea (*Vigna unguiculata* L. Walp) as influenced by genotype and postharvest re-hydration. *HortScience* 37(5):738. (Abstr).
- Blessington, T., A.L. Hale, and J.C. Miller, Jr. 2002. Variability in antioxidant activity of potato (*Solanum tuberosum*) as influenced by genotype and storage. *HortScience* 37(5):737-738. (Abstr).
- Nzaramba, N.M., D.C. Scheuring, A.L. Hale, and J.C. Miller, Jr. 2003. Antioxidant activity in cowpea determined on a single seed basis. *HortScience* 38(6):1298. (Abstr).