

RISK AWARE ROBUST DECISION MAKING IN POWER SYSTEMS WITH
RENEWABLE RESOURCES

A Dissertation

by

ANUPAM AJIT THATTE

Submitted to the Office of Graduate and Professional Studies of
Texas A&M University
in partial fulfillment of the requirements for the degree of

DOCTOR OF PHILOSOPHY

Chair of Committee,	Le Xie
Committee Members,	Shankar P. Bhattacharyya
	Mehrdad Ehsani
	Steven L. Puller
Head of Department,	Chanan Singh

December 2014

Major Subject: Electrical Engineering

Copyright 2014 Anupam Ajit Thatte

ABSTRACT

The increasing penetration of renewable generation poses significant risks to the reliable operation of power systems, mainly due to the variable and uncertain nature of the output of wind and solar resources. This dissertation presents a robust optimization based decision making framework in future power systems with high penetration of variable renewable resources.

The first part of this dissertation involves the modeling and analysis of a robust optimization based bidding strategy for the combination of a wind farm and an energy storage device participating in a deregulated electricity market. The selection of the uncertainty set for the robust optimization problem, based on the decision maker's risk preference, is also discussed. From the market participant's point of view improved utilization of the renewable resource, through storage enabled energy arbitrage, can lead to better economic performance. The storage device can provide firming power to the output of the wind farm, enabling the renewable resource to participate in the electricity market. The robust optimization based approach is compared to a deterministic optimization based approach through a numerical example.

The second part of this dissertation investigates the metric and the dispatch method needed for a more robust real-time market operation. A novel metric for evaluating system-wide ramp flexibility is proposed. A robust framework to ensure the reliable dispatch of generators is presented and analyzed. The robust model is compared to both the conventional economic dispatch as well as a proposed industry approach to managing system flexibility called the look-ahead dispatch. Further-

more, the formulation for a robust multi-zonal dispatch model is presented. The proposed robust model and flexibility index is demonstrated through a numerical on a modified IEEE 24 Bus Reliability Test System.

DEDICATION

To my family

ACKNOWLEDGEMENTS

I am very grateful to my advisor Dr. Le Xie for his motivation, guidance and support. It has been an honor to have worked with him. His work ethic and clear thinking has inspired me to do better than I thought I was capable of. Due to him I will always remember my time at Texas A&M with great fondness.

I would also like to thank my committee members, Dr. S. Bhattacharyya, Dr. M. Ehsani and Dr. S. Puller for their support and useful suggestions. I would also like to thank Dr. R. Balog for his time in the capacity of substitute committee member at my Ph.D. defense.

I am indebted to my Masters degree advisor Prof. Marija Ilic, at Carnegie Mellon University for introducing me to the world of research and rekindling my interest in power systems.

I would also like to thank Daniel Viassolo and Sunita Singh who were my collaborators at Vestas Wind Systems.

I am also grateful to current and past members of Dr. Xie's research group, my office mates and friends: Fan Zhang, Yingzhong Gu, Dae-hyun Choi, Omar Urquidez, Chen (Nathan) Yang, Yang Chen, James Carroll, Yun Zhang, Haiwang Zhong, Sadegh Modarresi, Xiaowen Lai, Meng Wu, Xinbo Geng and Hao Ming.

I would like to thank the ECE staff, particularly Tammy Carda, Jeanie Marshall, Anni Bruncker, and Claudia Samford.

I would specially like to thank my father and sister for their love and support.

Above all I dedicate my work to my mother who passed away in 2007.

NOMENCLATURE

ACE	Area Control Error
AGC	Automatic Generation Control
CAISO	California Independent System Operator
CPS	Control Performance Standard
DR	Demand Response
ED	Economic Dispatch
ISO	Independent System Operator
LMP	Locational Marginal Price
LORP	Lack of Ramp Probability
LP	Linear Programming
LSE	Load Serving Entity
MAE	Mean Absolute Error
MISO	Midcontinent Independent System Operator
MPC	Model Predictive Control
NERC	North American Electric Reliability Corporation
RO	Robust Optimization
SCED	Security Constrained Economic Dispatch
UC	Unit Commitment
VPP	Virtual Power Plant

TABLE OF CONTENTS

	Page
ABSTRACT	ii
DEDICATION	iv
ACKNOWLEDGEMENTS	v
NOMENCLATURE	vi
TABLE OF CONTENTS	vii
LIST OF FIGURES	ix
LIST OF TABLES	xii
1. INTRODUCTION	1
1.1 Motivation and Overview	1
1.2 Market Participant’s Perspective	4
1.2.1 Prior Work	4
1.2.2 Main Contributions from Market Participant’s Perspective	6
1.3 System Operator’s Perspective	8
1.3.1 Prior Work	8
1.3.2 Main Contributions from System Operator’s Perspective	10
1.4 Dissertation Outline	11
2. BACKGROUND	13
2.1 Robust Optimization	13
2.1.1 Budget of Uncertainty	15
2.1.2 Modulated Convex Hull	15
2.1.3 Risk Measures	16
2.2 Power System Scheduling	20
3. ROBUST OPTIMIZATION BASED BIDDING STRATEGY	26
3.1 Introduction	26
3.2 Formulation	29
3.2.1 Deterministic Optimization Based Bidding Strategy	31
3.2.2 Robust Optimization Based Bidding Strategy	33
3.2.3 Reformulation to Tractable Problem	34
3.2.4 Model Predictive Control Based Bidding Strategy	36

3.3	Numerical Examples	37
3.3.1	Day Ahead Market - One Day (Deterministic vs. Robust)	38
3.3.2	Day Ahead Market - Many Days (Deterministic vs. Robust)	45
3.3.3	Hour Ahead Market - One Day (Robust vs. MPC)	46
3.4	Decision Making Process for Wind Farm Operator	47
3.4.1	Decision Making Algorithm and Flowchart	49
3.4.2	Dashboard Tool for Bidding Strategy Selection	50
3.5	Performance of Robust Bidding Strategy	52
3.5.1	Relative Performance of Robust Bidding	55
3.5.2	Performance Guarantee	56
3.6	Case Studies	57
3.6.1	Case 1: Modulated Convex Hull Based Uncertainty Set	58
3.6.2	Case 2: Risk Measure Based Uncertainty Set	59
3.6.3	Comparison to Stochastic Programming	62
3.7	Joint Bidding in Energy and Regulation Markets	64
4.	ROBUST OPTIMIZATION BASED ECONOMIC DISPATCH	68
4.1	Introduction	68
4.2	System Operator Initiatives to Improve Dispatch	71
4.2.1	Ramp Capability Model	71
4.2.2	Look-Ahead Economic Dispatch	75
4.2.3	Comparison of Ramp Product	76
4.2.4	Need for Robust Economic Dispatch	77
4.3	Robust Economic Dispatch Formulation	77
4.3.1	Ramp Capability Reliability Index	80
4.3.2	Numerical	83
4.4	Zonal Robust Economic Dispatch with Tie-Line Limits	90
4.4.1	Nodal Robust Dispatch	94
4.4.2	LMP Formulation in Robust Dispatch	95
4.4.3	Zonal Configuration and Ramp Requirements	96
4.4.4	Case Study	98
5.	CONCLUSIONS	108
5.1	Robust Optimization Based Bidding Strategy	109
5.1.1	Summary	109
5.1.2	Future Work	110
5.2	Robust Optimization Based Economic Dispatch	110
5.2.1	Summary	110
5.2.2	Future Work	111
	REFERENCES	113

LIST OF FIGURES

FIGURE	Page
2.1 VaR and CVaR	19
2.2 Scheduled and actual demand for a hypothetical power system	22
3.1 Schematic of wind farm and energy storage	30
3.2 Nordpool market timeline	38
3.3 Electricity prices for scenario A	40
3.4 Results of deterministic optimization scenario A	40
3.5 Results of robust optimization for scenario A	41
3.6 Electricity prices for scenario B	42
3.7 Results of deterministic optimization for scenario B	42
3.8 Results of robust optimization for scenario B	43
3.9 Forecast and actual electricity price for 10 days	45
3.10 Forecast and actual wind farm power output for 10 days	46
3.11 Hour ahead energy and regulation prices	48
3.12 Results of robust optimization: hour-ahead market	48
3.13 Results of MPC optimization: hour-ahead market	49
3.14 Flowchart for wind farm operator decision making	51
3.15 Proposed dashboard for bidding strategy selection	52
3.16 Histogram of normalized price forecast error	54
3.17 Histogram of normalized wind power forecast error	54
3.18 Relative performance of robust optimization based bidding vs. price forecast error	56
3.19 Performance guarantee of robust optimization model	57

3.20	Electricity prices for given day (Case 1)	58
3.21	Results for $\epsilon = 0.93$	59
3.22	Electricity prices for given day (Case 2)	60
3.23	Results of robust optimization for $\beta = 10\%$	61
3.24	Wind deterministic and percentile forecast	62
3.25	Results of robust optimization for $\beta = 10\%$ (price) and 40% – 60% (wind)	63
4.1	Wind actual and forecast production in CAISO for a day	69
4.2	Wind production in CAISO for different days	69
4.3	Illustration of system ramp capability requirement	73
4.4	Lack of ramp probability	81
4.5	Lack of ramp probability for interval T1	86
4.6	Comparison of economic dispatch models	90
4.7	Modified IEEE 24 bus RTS system	99
4.8	System total electric load profile for entire day	100
4.9	System total wind profile for entire day	101
4.10	System total electrical load and net load profiles for entire day	101
4.11	System total gas generator profile for entire day	102
4.12	System total nuclear generator profile for entire day	102
4.13	System total coal generator profile for entire day	103
4.14	System total peaker (oil-fired) profile for entire day	103
4.15	System dispatch costs for entire day	104
4.16	North zone LORP for entire day	105
4.17	East zone LORP for entire day	105
4.18	Mean LORP comparison for north and south zones	106
4.19	Mean LORP comparison for east and west zones	106

4.20 Mean LORP comparison for different zones using robust dispatch . . . 107

LIST OF TABLES

TABLE	Page
3.1 Nomenclature for bidding strategy	31
3.2 Wind farm and storage device parameters	37
3.3 Results of Monte Carlo runs (DO: deterministic optimization, RO: robust optimization, result = mean daily total profit, change = % change relative to DO case, WC = worst case realization profit) . . .	44
3.4 Impact of choice of uncertainty set of wind power	46
3.5 Impact of choice of uncertainty set of price	47
3.6 Results of Monte Carlo simulation for different ϵ	59
3.7 Results of Monte Carlo simulation for different β	61
3.8 CVaR for combinations of β and MAE	61
3.9 Results of Monte Carlo simulation for wind uncertainty sets	63
3.10 Nomenclature for joint energy and frequency regulation bidding . . .	65
4.1 Notation for economic dispatch models	74
4.2 Ramp product vs. look-ahead	76
4.3 Ramp product vs. regulation	77
4.4 Generator characteristics	83
4.5 Net load forecasts	84
4.6 Ramp capability requirements	84
4.7 Conventional economic dispatch results	85
4.8 Results of dispatch with ramp product	85
4.9 Robust economic dispatch results	87
4.10 Generation cost comparison	87

4.11	Generation cost and reliability comparison of dispatch methods . . .	88
4.12	Summary of monte carlo results	90
4.13	Notation for multi-zonal robust dispatch	91
4.14	Generator parameters for IEEE 24 bus system	100

1. INTRODUCTION*

1.1 Motivation and Overview

Over the past decade, in power systems around the world, the penetration of generation from renewable resources such as wind and solar has increased significantly. Given the decrease in the cost of renewable generation technologies and policies such as renewable portfolio standards, the share of renewables in the generation portfolio is expected to increase in the future. The variable and uncertain nature of these renewable resources poses certain challenges for the reliable and cost-effective operation of power systems.

In deregulated electricity markets the dispatch schedule of generators is decided by independent system operators (ISOs) many hours in advance of the actual operating time, based on the results of an optimization problem. Market participants (both generators and load serving entities) submit their sale and purchase bids for the operating day to the ISO which clears the market. As a result the generators only have a forecast of the market clearing prices at the time they make their bidding decision. Additionally, for renewable generators the amount of power they can produce can not be scheduled but depends on the physical availability of the renewable resource. Given the forecast errors, even with the best forecasting techniques, making the optimal decision as to the bidding strategy is a challenge. Further, due to their variable and uncertain nature, it is difficult for system operators to dispatch

*This section is in part a reprint of the material in the following papers: (1) Reprinted with permission from A. A. Thatte, L. Xie, D. E. Viassolo and S. Singh, "Risk Measure based Robust Bidding Strategy for Arbitrage using a Wind Farm and Energy Storage," *IEEE Transactions on Smart Grid*, vol. 4, no. 4, pp. 2191-2199, Dec. 2013. Copyright 2013, IEEE. (2) Reprinted with permission from A. A. Thatte, X. A. Sun and L. Xie, "Robust Optimization Based Economic Dispatch for Managing System Ramp Requirement," *Proceedings of the 47th Hawaii International Conference on System Sciences*, Waikoloa, HI, pp. 2344-2352, Jan 6-9, 2014. Copyright 2014, IEEE.

renewable resources as they dispatch conventional generation. This has an adverse impact on the reliable operation of power systems.

Energy storage can be used in conjunction with renewable resources to mitigate the impact of variability and uncertainty [1]. Energy storage devices can be leveraged to improve economic benefits through the exploitation of arbitrage opportunities as well as provide technical benefits by participating in ancillary services such as frequency regulation. Combining revenue streams from multiple applications in deregulated electricity markets could justify the high investment costs required for storage devices [2]. The combination of renewable generators and energy storage can be dispatched using dispatch strategies obtained from optimization based methods.

In these optimization problems uncertainty arises due to both the market clearing prices as well as the output of the renewable generators. Stochastic programming is a popular optimization method used to deal with uncertainty. In stochastic programming models usually the assumption is made that the probability distribution of the uncertain data is either known or can be estimated. However, in practice information about the probability distribution of uncertain variables may not be available. Further, stochastic programming is generally computationally intensive due to the large number of scenarios that have to be considered in order to accurately sample the uncertain variable [3].

In recent years, robust optimization (RO) has attracted significant interest as a framework for optimization under uncertainty [4]. The approach has several attractive modeling and computational advantages. First, it uses a deterministic set-based method to model parameter uncertainty. This method requires only moderate amount of information, such as the support and moments, of the underlying uncertainty. At the same time, it provides the flexibility to incorporate more detailed information. There is also a deep connection between uncertainty sets and risk

theory [5]. Second, the robust optimization approach yields a solution that immunizes against all realizations of uncertainty data within the uncertainty set, rather than a finite number of sample scenarios. Such robustness is consistent with the reliability requirement of power system operations, given that the cost associated with constraint violations is very high. Third, for a wide class of problems, the robust optimization models have similar computational complexity as the deterministic counterparts. This computational tractability makes robust optimization a practical approach for many real-world applications.

In this dissertation robust optimization is applied to the decision making in power systems, both from the price taking market participant's perspective as well as the system operator's perspective. The notion of risk is incorporated into the formulation through the related choice of the uncertainty set. The impact of the choice of uncertainty set on the performance of the solution is also examined. Thus, this dissertation presents a *risk aware robust decision making framework* for generators in power systems with high penetration of renewable resources such as wind and solar.

The contributions of this dissertation are as follows: (1) the robust optimization approach for obtaining the optimal decisions for generators in deregulated electricity markets, under increasing uncertainty due to the penetration of renewables is introduced and studied; (2) a risk preference based robust approach to optimal bidding strategy selection for improving the utilization of the renewable resource and energy storage, from the *market participant's perspective* is studied; and (3) a robust risk aware framework for ensuring the reliable dispatch of generation, by maintaining system power balance and adequate ramp capability, from the *system operator's perspective*, is studied.

1.2 Market Participant's Perspective

1.2.1 *Prior Work*

In the deregulated electricity industry, generation companies sell their power output either through auctions in the spot market or directly to load serving entities (LSEs) through bilateral contracts. The generators submit their bids for the hour by hour production for the entire day in the day-ahead market to the ISO. The system operator collects sale and purchase bids from both generators and LSEs and clears the market thereby determining the equilibrium price and quantity of electrical power.

The selection of the bidding strategy for a generator can be formulated as an optimization problem which aims to maximize the total profit from sale of electricity in the day-ahead market.

In [6] the optimal bidding strategy for a price-taking power producer is formulated as a mixed-integer linear programming problem. In [7] the value of combining wind farms with energy storage for energy arbitrage in short-term electricity markets has been analyzed. Castronuovo and Lopes [8] obtained the optimal operational strategy for a combined wind and pumped storage facility based on deterministic linear optimization for scenarios generated using a Monte Carlo simulation approach. Kazempour et al. [9] applied mixed-integer non-linear programming to the self-scheduling problem for the combination of a hydro plant with pumped storage across energy and ancillary service markets. In [10] a dynamic programming algorithm is used to obtain the optimal operational strategy for a wind power plant with a generic energy storage device. In [11] an optimization algorithm for arbitrage is proposed to obtain the pumping and generating schedule of a pumped-storage unit. In [12] the bidding strategy for a virtual power plant (VPP) participating in joint energy and

spinning reserve market is obtained using a genetic algorithm. The two stage stochastic programming approach has been applied to obtain optimal bidding strategies for price-taking generators [13, 14]. In fact there are more examples of the application of the stochastic programming approach to problems in power systems [15, 16].

Thus, many researchers have proposed using the stochastic programming approach to deal with uncertainty in generator decision making. However, the stochastic programming approach is computationally challenging due to the large number of scenarios that have to be considered. Additionally, stochastic programming also requires knowledge of the probability distribution of uncertain variables, which may not be available.

Another relevant issue is the emergence of the smart grid and the development of energy storage technologies. Due to the increasing penetration of variable and uncertain renewables in the generation mix, the importance of energy storage in power system operations has increased. These technologies enable the mitigation of the adverse impact of renewables on reliable grid operation. Significant efforts have been spent on reducing the cost and improving the technical performance of energy storage technologies. These storage technologies include batteries, flywheels, compressed air, pumped-hydro, ultracapacitors, and superconducting magnetic energy storage [17].

Energy storage may also be provided through *flexible load management*, such as controlling building thermal storage [18] and frequency control of loads [19, 20]. Thermal loads such as water heaters, water chillers, or air conditioning systems can reduce their consumption in response to high electricity prices thereby achieving savings. The bidirectional communication made possible by smart grid infrastructure enables the active participation of distributed storage and demand resources in real time electricity markets [21]. Through aggregation of a large number of small-scale

units these Demand Response (DR) resources can be seen as viable service providers in electricity markets [22, 23].

The advantages of energy storage in power system operations have been discussed in a large body of literature. For example, in [24] a superconducting magnetic energy storage system was used for stabilizing the transients in long distance transmission networks. For frequency regulation services, fast responsive storage such as flywheels can be utilized to smooth out the frequency deviations due to the increasing penetration of variable renewable resources [25, 26, 27, 28]. Also the inertial response of loads such as thermal energy in buildings can be utilized for frequency regulation in electricity markets [18, 29]. Various types of batteries ranging from lead-acid to flow batteries are now being considered for power system applications [17].

Given that energy storage is an important element in the smart grid environment, it is essential to understand its operational value in order to promote investment in this resource. Energy storage can be considered as a service which provides value to electricity market operations across time scales. Thus, through cross market co-optimization in deregulated electricity markets, an improved value proposition can be obtained in order to justify the investment in energy storage technologies [2].

1.2.2 Main Contributions from Market Participant's Perspective

In Section 3, robust optimization is applied to obtain the bidding strategy for the combination of a wind farm and an energy storage device, which together act as a price-taking generator. The main feature of the robust optimization approach is that it uses a *non-probabilistic* approach to deal with the uncertainty. Uncertainty is addressed by constructing an uncertainty set and the solutions obtained are robust to all realizations of uncertain data within the defined uncertainty set. This definition of uncertainty leads to a more tractable problem. The question that arises in this

regard is as to the selection of these uncertainty sets. One method that has been suggested to determine the uncertainty set is to use risk measures commonly used in the finance industry [5]. In financial portfolio optimization the future values of the assets are uncertain, similarly in the generator scheduling problem the market clearing price of electricity in the day-ahead market is uncertain at the time of generator bidding. Thus, the uncertainty set can be determined based on a coherent risk measure such as Conditional Value at Risk (CVaR) [30]. Consequently a robust optimization bidding strategy can be obtained based on the risk preference of the renewable generator operator.

Robust optimization solves for the *worst-case*, consequently it will yield conservative results if the forecast errors are low. However, since the robust approach yields solutions that are immunized to all realizations of uncertain data within the uncertainty set, it may be a suitable approach when forecast errors are high.

The main contributions of this section are:

- presents the formulation for a robust optimization based bidding strategy for the combination of a wind farm and an energy storage device in deregulated electricity markets.
- analyzes and compares the performance of the robust optimization approach to the deterministic approach.
- verifies through a case study that the robust approach has a higher probability of yielding better economic returns compared to the deterministic optimization approach, for a high forecast error in day-ahead electricity market clearing price.
- compares the robust optimization based bidding strategy to a stochastic opti-

mization based approach.

- proposes the use of risk measure based uncertainty sets for determining the optimal bids in the day-ahead electricity market. Risk measures used in the finance industry can be used to incorporate decision maker's risk aversion in the decision making process.
- illustrates through case studies, the risk measure based robust bidding strategy for an energy arbitrage application using the combination of a wind farm and a generic energy storage.

1.3 System Operator's Perspective

1.3.1 Prior Work

The increasing penetration of renewable resources such as wind and solar poses a challenge to the goal of ISOs to manage the power system with a reliable and cost effective approach. Due to the limited control over the output of renewable resources as well as associated forecast errors the ISOs will have to deal with an increasing amount of uncertainty and variability in the system [31].

Due to the higher penetration of variable renewables and increasing demand side participation enabled by smart grid technologies, unit commitment in deregulated electricity markets has become more challenging. In the power system operations literature, stochastic programming has been adopted by many researchers to solve unit commitment problems. Takriti et al. [32] used the stochastic programming approach for solving the unit commitment problem while also considering uncertainty in fuel prices. Nowak et al. [33] used a two-stage stochastic integer programming model in order to incorporate day-ahead trading into the unit commitment of a hydro-thermal power system. Many researchers have worked on the unit commitment problem using

methods ranging from dynamic programming to evolutionary programming [34].

Recently researchers have proposed applying robust optimization based approaches for the unit commitment problem [35]. Bertsimas et al. [36] proposed a two stage adaptive robust optimization model for the security constrained unit commitment problem in the presence of nodal net injection uncertainty. The method used is based on Benders decomposition and the level of conservatism of the solution is controlled by an uncertainty budget. Similarly [37, 38, 39] also apply robust optimization for the unit commitment problem, with the uncertainty set determined by an uncertainty budget. Jiang et al. [40] propose a method to provide a robust unit commitment schedule for thermal generators in the day-ahead market with wind power fluctuations.

Another significant issue is the temporary price spikes experienced by many ISOs in the real time electricity market due to shortages attributed to a lack of system ramp capability [41]. The main causes of these shortages include variability of load, scheduled interchanges and non-controllable generation resources (primarily wind) as well as uncertainty associated with short term forecasts. Due to the physical limitations on ramp rates generators are unable to respond effectively to these price spikes. The current practices to deal with ramp shortages include increasing reserve margins, starting fast-start units (such as gas turbines) and out of market dispatch methods that involve operator action. However, these approaches are usually high cost or create some market distortion. It is important for ISOs to have additional flexibility for dispatchable generation resources through the market clearing process. The Security Constrained Economic Dispatch (SCED) decision needs to be robust to the uncertainties so that the critical system power balance requirement is not violated.

Some ISOs are considering modifying their economic dispatch model to include

additional ramp capability constraints. Midcontinent ISO (MISO) has proposed an economic dispatch model with *ramp product*, which aims to cover forecast variability in net load as well as uncertainty, which is calculated based on a statistical analysis of historical data available to the system operator [42]. California ISO (CAISO) is also investigating a *flexible ramping product* in order to create additional flexibility in the dispatch so that the occurrences of ramp shortage and temporary price spikes are greatly reduced [43]. However, even with the ramp capability modification there is a significant probability of shortage events due to lack of system ramp capability.

1.3.2 Main Contributions from System Operator's Perspective

In Section 4 a robust optimization based economic dispatch model is proposed which gives dispatch decisions that are robust to uncertainties in the system net load.

The main contributions of this section are as follows:

- presents a robust optimization based economic dispatch model for ensuring a reliable dispatch solution for the power system.
- proposes a novel metric for dispatch flexibility based on a probabilistic risk measure.
- illustrates the proposed robust model on a small test system for the real time economic dispatch.
- compares the robust model to the current conventional economic dispatch model as well as the industry proposed ramp product and look-ahead dispatch models, in terms of dispatch costs, system reliability and their impact on Locational Marginal Prices (LMPs).
- presents the formulation for the implementation of robust dispatch in a multi-zonal system with transmission line flow constraints considered.

- illustrates the proposed robust model on a multi-zonal IEEE 24 bus Reliability Test System for real time economic dispatch using realistic data. To compare the robust approach to the existing and industry proposed models in terms of dispatch costs and the proposed flexibility metric.

1.4 Dissertation Outline

The rest of this dissertation is organized as follows. Section 2 presents the background on robust optimization, uncertainty sets, risk measures used in finance industry, incorporating decision makers risk aversion and the risk measure based construction of uncertainty sets. This section also describes the power system scheduling operations, specifically the conventional economic dispatch and automatic generation control. Also NERC's Control Performance Standard (CPS) criteria for secondary frequency control are reviewed.

Section 3 presents the formulation of a robust optimization based bidding strategy for dispatching the combination of a wind farm and an energy storage device. The bidding strategy increases the profit of the renewable generator by exploiting energy arbitrage opportunities. Further, the risk preference of the user can be incorporated through the choice of the uncertainty set for the robust problem. Two approaches that incorporate risk are considered for the choice of uncertainty sets: (i) modulated convex hull, and (ii) coherent risk measure CVaR used in finance. In order to illustrate these approaches case studies are presented. The decision making process for selecting the optimum bidding strategy, from the point of view of the wind farm operator, is also presented. The robust approach is compared to the deterministic, stochastic and model predictive control approaches.

Section 4 presents a robust optimization based economic dispatch model for ensuring adequate system ramp capability. The proposed robust model is compared

existing and industry proposed economic dispatch approaches: (i) ramp product, and (ii) look-ahead dispatch. Further, a metric called the lack-of-ramp probability (LORP) index is proposed to measure the flexibility of dispatch. This probabilistic metric can be used to compare the different economic dispatch models in terms of the risk of shortage events occurring, due to lack of system ramp capability. A numerical assessment on a test system is presented, including Monte Carlo simulations in order to compare the economic dispatch models. Further, a robust dispatch formulation for a multi-zonal system including transmission line flow constraints is presented. The implementation of the proposed multi-zonal robust dispatch is demonstrated through a case study on an IEEE 24 bus Reliability Test System.

Finally in Section 5, the main contributions of this dissertation are summarized and some future research directions are suggested.

2. BACKGROUND*

2.1 Robust Optimization

Robust optimization offers a non-probabilistic approach to deal with uncertainty through the use of an uncertainty set. Unlike stochastic programming in this approach knowledge of the probability distribution of the uncertain variable is not required. For many problems in power systems it may be difficult to accurately estimate the probability distribution of the uncertain variable. Further a large number of scenarios have to be considered in order to get a reasonable guarantee on the solution, which leads to large problem size.

Robust optimization solves for the worst case of uncertainty within the uncertainty set, hence the solution is feasible for all realizations of uncertain variables within the given uncertainty set. The other advantage is that for many classes of optimization problems the RO formulation is tractable [44].

The generic robust optimization formulation is given as:

$$\begin{aligned} \min_{x \in X} f(x, u) \\ \text{s.t. } g(x, u) \geq 0, \forall u \in \mathcal{U} \end{aligned} \tag{2.1}$$

where x is a vector of decision variables which belong to set $X \subseteq \mathbb{R}^n$, f and g are

*This section is in part a reprint of the material in the following papers: (1) Reprinted with permission from A. A. Thatte, D. E. Viassolo, and L. Xie, "Robust bidding strategy for wind power plants and energy storage in electricity markets," in *Proc. IEEE Power Energy Soc. Gen. Meet.*, San Diego, CA, Jul. 22-26, 2012, pp. 1-8. Copyright 2012, IEEE. (2) Reprinted with permission from A. A. Thatte, L. Xie, D. E. Viassolo and S. Singh, "Risk Measure based Robust Bidding Strategy for Arbitrage using a Wind Farm and Energy Storage," *IEEE Transactions on Smart Grid*, vol. 4, no. 4, pp. 2191-2199, Dec. 2013. Copyright 2013, IEEE. (3) Reprinted with permission from A. A. Thatte, F. Zhang and L. Xie, "Frequency aware economic dispatch," *Proc. North American Power Symposium (NAPS)*, Boston, MA, Aug. 4-6, 2011, pp. 1-7. Copyright 2011, IEEE.

the objective function and constraints respectively, u are the uncertain parameters which take values in the uncertainty set \mathcal{U} .

Thus we obtain the optimal solution x^* where the constraint $g(x, u) \geq 0$ is satisfied for all realizations of the uncertain variable u within the defined uncertainty set \mathcal{U} .

The general uncertain linear programming (LP) problem is given as

$$\begin{aligned} \min_{x \in X} \quad & c^T x \\ \text{s.t.} \quad & \tilde{a}^T x \geq b \end{aligned} \tag{2.2}$$

where without loss of generality the uncertainty is assumed to affect only the constraint coefficients \tilde{a} . Every element of the vector \tilde{a} is assumed to be subject to uncertainty and belongs to the uncertainty set \mathcal{U} .

The robust counterpart to the uncertain LP problem is computationally tractable for many types of uncertainty sets, and for polyhedral uncertainty sets the robust counterpart can be converted to a deterministic LP problem [4, 44].

The uncertainty set can be based on some historical information about the values of the uncertain parameters. If information about the variance of the uncertain coefficients is available then that information can be used to construct polyhedral uncertainty sets [45].

In order to limit the conservatism of the solution there are different approaches available in the literature. One way is to select the uncertainty set based on a budget of uncertainty. Another approach is to use a modulated convex hull based on available data. Further, based on the correspondence of the uncertainty set with risk measures commonly used in finance we can construct uncertainty sets for the generator dispatch problem [5, 30].

2.1.1 Budget of Uncertainty

The general robust optimization problem is very conservative since we consider the worst case for every uncertain variable. An approach to allow the decision maker to control the degree of conservatism is suggested in [46].

Bertsimas et al. [36] propose a way to construct the uncertainty set which is as follows. Suppose every element of the vector \tilde{a} belongs to a symmetrical interval $[\hat{a} - \Delta a, \hat{a} + \Delta a]$, where \hat{a} and Δa represent the nominal values and deviations respectively. The polyhedral uncertainty set can be defined as

$$\mathcal{U} = \left\{ \tilde{a}_i : \sum_{i=1}^N \frac{|\tilde{a}_i - \hat{a}_i|}{\Delta a} \leq \Gamma \right\} \quad (2.3)$$

where $|\Delta a_i| = |\alpha \hat{a}_i|$, α being a scalar constant in the set $[0, 1]$ which gives the relation of the deviation Δa_i to the nominal value \hat{a}_i . N is the number of uncertain variables and Γ is referred to as the *budget of uncertainty* which is used to adjust the level of conservatism of the solution. When $\Gamma = 0$ the problem reduces to the deterministic case which solves the problem using the nominal values i.e., expected values of the uncertain coefficients. Γ can be adjusted according to the trade-off between decision maker's risk preference and the conservatism of the solution.

2.1.2 Modulated Convex Hull

Another approach to defining the uncertainty set, called the *modulated convex hull* is as follows [47]:

We choose parameter $\epsilon \in [0, 1]$, for which we get the uncertainty set as

$$\mathcal{U} = \hat{a} + (1 - \epsilon)(\text{conv}\{a_1, a_2, \dots, a_N\} - \hat{a}) \quad (2.4)$$

where \hat{a} is the nominal or expected value of the uncertain vector and $a_i, i = 1, \dots, N$ are vectors that represent the historic data of the random vector. As ϵ increases from 0 (worst case) to 1 the uncertainty set collapses to \hat{a} . Therefore, the uncertainty set for price can be defined around the forecast value based on decision maker's choice of parameter ϵ . Thus this parameter ϵ can be used to represent decision maker's risk preference.

2.1.3 Risk Measures

In the field of finance the portfolio allocation problem is an optimization problem where the uncertain coefficients are the future asset returns. Risk measures are used to quantify the likelihood and size of potential losses. A risk measure is effectively a mapping from a set of random variables (e.g., portfolio returns) to the set of real numbers. The aim of the portfolio optimization is to find the minimum risk portfolio in the set of feasible portfolios. Analogous to this, the bid scheduling problem for the energy from the combination of a wind farm and an energy storage device can also be framed as an optimization problem. The aim is to maximize the profit from sale of electricity under uncertainties in electricity price forecasting and wind power forecasting.

2.1.3.1 Value at Risk (VaR)

Value at Risk (VaR) is a risk measure which is widely used in finance. VaR is computed as the maximum profit over a target time horizon such that the probability of the profit being less than or equal to this value is less than or equal to $1 - \beta$ [48]. Thus VaR can be used to represent the monetary risk associated with the bid schedule of the combination of the wind farm and energy storage, due to uncertainties in the forecasts.

Given a confidence level $\beta \in (0, 1)$ and the normally distributed random variable,

profit, Value at Risk for the operating day is defined as

$$VaR_\beta(\textit{profit}) = \max\{t | Pr(\textit{profit} \leq t) \leq 1 - \beta\} \quad (2.5)$$

The main disadvantages of VaR are that (i) it does not capture tail cases, and (ii) VaR is not coherent.

2.1.3.2 Coherent Risk Measures

A risk measure $\rho(\cdot)$ is coherent if it satisfies the following four conditions [49].

1. Sub-additivity: $\rho(X + Y) \leq \rho(X) + \rho(Y)$
2. Homogeneity: For any $\xi \geq 0$, $\rho(\xi X) = \xi\rho(X)$
3. Monotonicity: $\rho(X) \leq \rho(Y)$ if $X \geq Y$
4. Translational invariance: $\rho(X + c) = \rho(X) - c$, for any constant c

These axioms have certain interpretations as applied to financial investments. Sub-additivity means that the risk of a combination of two investments can not be greater than the sum of their individual risks. Homogeneity means that the risk scales with the size of the investment. Monotonicity means that if the value of one investment is always greater than another, then the risk associated with the former is always lower. Translation invariance states that the addition of a sure amount of capital $c > 0$ to a position lowers the risk of that position by the amount c .

Convexity, defined as $\xi \in [0, 1]$, $\rho(\xi X + (1 - \xi)Y) \leq \xi\rho(X) + (1 - \xi)\rho(Y)$ follows from above conditions. The main consequence of coherency is the preservation of convexity, which in turn implies computational tractability of optimization [50, 30].

2.1.3.3 Conditional Value at Risk (CVaR)

Conditional Value at Risk (CVaR) is defined as the conditional expectation of the profit, given that the profit is less than or equal to the VaR value. Thus given a confidence level $\beta \in (0, 1)$,

$$CVaR_{\beta}(profit) = E[profit|profit \leq VaR_{\beta}] \quad (2.6)$$

Therefore CVaR is the expected value of the worst $(1 - \beta)$ cases of profit. Compared to VaR, CVaR is a conservative risk measure since it captures the tail of the probability distribution of profit. The main advantage of CVaR is that it is coherent [51]. This addresses the motivation of using the CVaR risk measure in this case. CVaR being a coherent risk measure preserves the convexity of the robust counterpart to the linear optimization problem with uncertain data. Therefore, the resulting robust optimization problem is tractable.

CVaR captures the tail of the bidding profit scenarios as specified by a confidence level β (Fig. 2.1). Therefore for a given confidence level CVaR can be used as a performance measure to compare different bidding strategies. By changing the confidence level the conservatism level of this performance measure can be adjusted. For instance if we take $\beta = 100\%$ the CVaR measure is reduced to the worst case scenario only. Whereas if we take $\beta = 0\%$ then CVaR gives the mean for all profit scenarios. Thus the confidence level β can be used to represent the decision maker's risk aversion. A more risk averse decision maker may choose a larger value of β , while a risk tolerant decision maker may choose a smaller value of β .

Expressing the decision maker's risk preference as a coherent risk measure, allows us to formulate the optimization problem with uncertain data as a robust optimization problem with a convex uncertainty set. Example 3.2 in Bertsimas and Brown

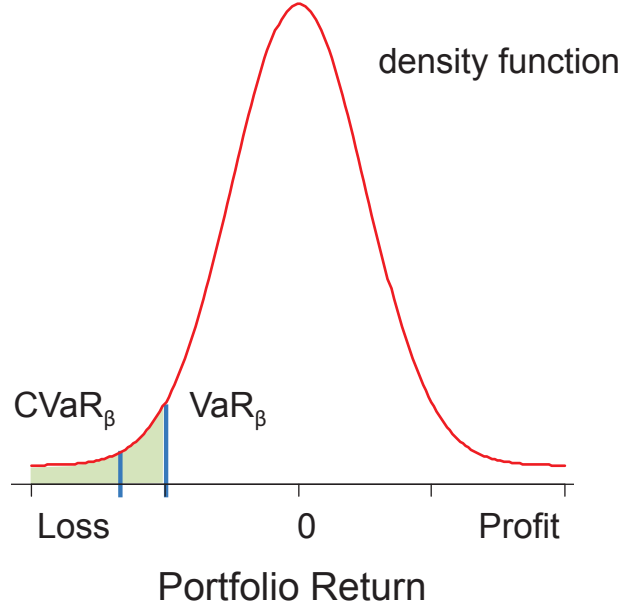

Figure 2.1: VaR and CVaR

[5] specifies the link between CVaR risk measure and polyhedral uncertainty sets, as follows.

Given N samples of data i.e., $\{a_1, \dots, a_N\}$, the uncertainty set for the uncertain vector \tilde{a} corresponding to $CVaR_\beta$ is

$$\mathcal{U} = \text{conv} \left(\left\{ \frac{1}{1-\beta} \sum_{i \in I} p_i a_i + \left(1 - \frac{1}{1-\beta} \sum_{i \in I} p_i\right) a_j : \right. \right. \\ \left. \left. I \subseteq \{1, \dots, N\}, j \in \{1, \dots, N\} \setminus I, \sum_{i \in I} p_i \leq 1 - \beta \right\} \right) \quad (2.7)$$

If we assume the probability distribution of data samples a_i as $p_i = 1/N, \forall i$ and also take $1 - \beta = j/N$, then for some $j \in \mathbb{Z}_+$ this has the interpretation of the convex hull of all j -point averages of matrix $A = [a_1, \dots, a_N]$.

2.2 Power System Scheduling

Electric power system operation aims at maintaining certain bounds with respect to state variables such as voltage and frequency, via a series of control actions at various hierarchical levels. The real power-frequency control sub-problem is addressed through a sequence of temporally separated control actions, based in part on the natural decomposition of system load which is as follows [52, 53]:

1. day-ahead load forecast,
2. real-time (every 5 minutes) updated forecast load, and
3. random fluctuations within the 5 minute interval.

The main task of power system scheduling is to match the total system load with generation. Imbalances between generation and load lead to frequency deviating from its nominal value, which in the US is 60 Hz. The aim of system operators is to maintain the system frequency within certain bounds of 60 Hz, and in doing so meet the demand using the least cost generation. Corresponding to the above temporal decomposition of system load, the three stages of generator real power control are as follows [54]:

1. unit commitment (UC),
2. economic dispatch (ED), and
3. primary and secondary frequency control

Unit commitment aims to find the on/off scheduling of the generators in the system in order to meet the forecasted load. Economic dispatch is carried out to determine the amount of power that should be produced by the generators which are

committed during each market interval of the operating day. Secondary frequency control is done through a system known as Automatic Generation Control (AGC). The AGC control signal is sent by the system operator to participating generators so as to control their power output in order to regulate the system frequency. Whereas, primary control is implemented through the governor control of the synchronous generator, which is a local control.

This temporal separation of control actions means that when making ED decisions, it is implicitly assumed that the system frequency will be stable and will remain on average at the nominal value (i.e., 60 Hz for US). This assumption is justified since usually the magnitude of the random fluctuations in load is much smaller than the magnitude of the near-term updated load forecast. Also the random fluctuations can be assumed to be zero-mean Gaussian, therefore under normal conditions the primary and secondary control actions will stabilize the frequency around the nominal value. Thus we are able to decompose the problem into several simpler sub-problems at the different levels of the power system hierarchy. The temporal separation principle and hierarchical structure have provided a fast and near-optimal approach to solving what amounts to a large-scale complex dynamic system problem [53].

Fig. 2.2 illustrates the scheduled or forecast demand as well as the actual demand for a hypothetical power system. Economic dispatch is used to meet this scheduled demand by dispatching power from participating generators. The actual demand comprises of small and rapid fluctuations around this scheduled demand. The AGC system is used to maintain the system power balance by tracking these fluctuations on a moment to moment basis through the ancillary service known as *frequency regulation* [55].

Both ED and AGC decisions are implemented physically at the same input of the generator control system, namely the setpoint of the speed governor. However, ED

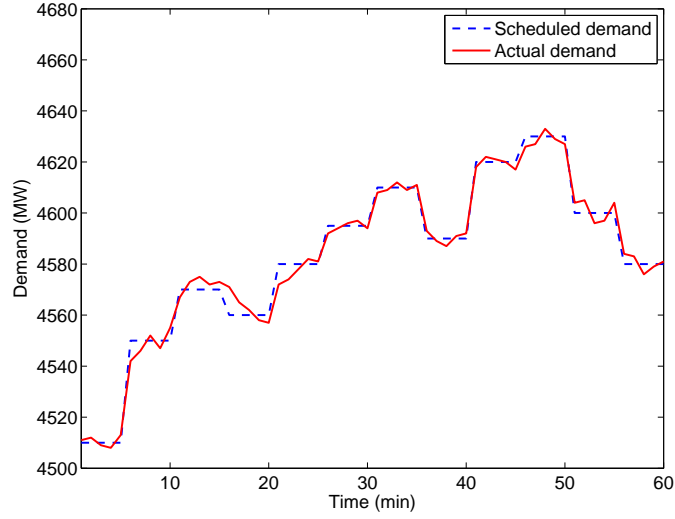

Figure 2.2: Scheduled and actual demand for a hypothetical power system

and AGC operate at different time scales. ED is typically carried out every 5 to 15 minutes and aims to balance the load requirement in the most economical way. The signal to execute AGC is sent out typically every 2 to 4 seconds, and the aim of AGC is to restore the system frequency to its nominal value within seconds to minutes.

The conventional ED can be formulated as the following deterministic optimization problem [31].

$$\min_{P_{Gi}} \sum_{i=1}^N C_{Gi}(P_{Gi}) \quad (2.8)$$

s.t.,

$$\sum_{i=1}^N P_{Gi} = \sum_{j=1}^M P_{Lj} \quad (2.9)$$

$$P_{Gi}^{min} \leq P_{Gi} \leq P_{Gi}^{max} \quad \forall i \quad (2.10)$$

$$-R_i \leq P_{Gi} - P_{Gi}^0 \leq R_i \quad \forall i \quad (2.11)$$

$$|F| \leq F^{max} \quad (2.12)$$

where

$C_{Gi}()$ is the cost function of generator i ,

P_{Gi} is the power output of generator i ,

P_{Gi}^{min} is the minimum output level of generator i ,

P_{Gi}^{max} is the maximum output level of generator i ,

P_{Gi}^0 is the generator power output in the previous time interval,

P_{Lj} is the power demand of load j ,

R_i is the ramp rate of generator i ,

F is the vector of line flows,

F^{max} is the vector of line flow limits.

The objective of the ED problem (2.8) is to minimize the total cost of dispatch of all generators. The main constraint is to balance the system demand with generation (2.9). The generator outputs should be within their upper and lower limits (2.10). The inter-temporal generator ramp rates also constrain the power outputs (2.11). Also, the line flows on all transmission lines should be within the specified limits (2.12).

The objective of the conventional Area Control Error (ACE) based AGC is to adjust the governor set points of the generators and thus change their power outputs, in order to maintain the system frequency close to the nominal value. If the frequency bias of each area is chosen to correspond to its natural response coefficient β then ACE provides a measure of the local power imbalance in a specific control area. Therefore if the ACE of an area is zero, then generation and demand are balanced [54].

$$ACE = T_a - T_s - 10B(F_a - F_s) \quad (2.13)$$

where

T_a and T_s are net actual and scheduled tie flows (in MW) leaving a control area, respectively

B is the frequency bias coefficient (MW/0.1 Hz),

F_a and F_s are actual and scheduled system frequency (in Hz), respectively.

The performance of AGC can be monitored using NERC's Control Performance Standard (CPS). Control areas are required to ensure compliance with the NERC CPS in order to maintain reliability. CPS is composed of two parts - CPS1 and CPS2. Each control area must have at least 100% compliance with CPS1 and 90% compliance with CPS2. The formulae for calculating CPS compliance are stated as follows [56]:

$$CF_{12month} = AVG_{12month} \left[\left(\frac{ACE}{-10B} \right)_1 \times \Delta F_1 \right] \quad (2.14)$$

$$CPS1 = \left(2 - \frac{CF_{12month}}{(\epsilon_1)^2} \right) \times 100\% \quad (2.15)$$

where ϵ_1 is the CPS1 control target of the Interconnection (in Hz), ΔF_1 is the clock-minute average of frequency deviation (in Hz), B is the frequency bias of the control area (in MW/0.1 Hz), $\left(\frac{ACE}{-10B} \right)_1$ and is the clock-minute average of ACE divided by the control area's frequency bias (in Hz).

CPS2 compliance is calculated based on a statistically derived bound L_{10} on the ten-minute average of ACE

$$AVG_{10minute}(ACE_i) \leq L_{10} \quad (2.16)$$

where:

$$L_{10} = 1.65\epsilon_{10}\sqrt{(-10B_i)(-10B_s)} \quad (2.17)$$

ϵ_{10} is a constant derived from the targeted frequency bound, and B_s is the sum of the Frequency Bias Settings of the Balancing Authority Areas in the Interconnection.

$$CPS2 = \left[1 - \frac{V_{month}}{TP_{month} - UP_{month}} \right] \times 100\% \quad (2.18)$$

V_{month} is a count of the number of periods that ACE clock-ten-minute average exceeded L_{10}

TP_{month} are the total periods of the month

UP_{month} are the unavailable periods of the month

The conventional methods of power system operation for real power-frequency control are based on the assumption that generation is dispatchable and usually predictable. However, the penetration of variable generation, such as wind and solar, in power systems is increasing. Due to their inherent variability and unpredictability these resources pose a challenge for the reliable operation of power systems.

3. ROBUST OPTIMIZATION BASED BIDDING STRATEGY*

3.1 Introduction

This section describes the formulation of an optimization based bidding strategy for dispatching a wind farm in combination with energy storage. Through coordination with energy storage devices, variable wind generators can be utilized as dispatchable energy producers in the deregulated electricity market. The total profit from sale of electricity can be increased by exploiting arbitrage opportunities available due to the variation of electricity prices over time in the electricity market.

The variable and uncertain nature of the wind resource poses challenges to operations of the electricity grid. Despite improvements in forecasting methods it is difficult for system operators to dispatch wind generators as they dispatch conventional generators. Storage technologies can help in firming the output of wind generation and provide benefits to the system over different time scales. The combined operation of renewable generators and energy storage allows for greater flexibility in power output decision making. As an example, storage can help in exploiting arbitrage opportunities due to temporal variations in electricity prices over a duration of several hours [57]. In addition, fast acting storage technologies can allow wind generators to schedule their dispatch with more certainty, thereby enabling them to participate in ancillary services such as frequency regulation [17]. Improved utilization of wind energy can help in improving the operational economic performance of

*This section is in part a reprint of the material in the following papers: (1) Reprinted with permission from A. A. Thatte, D. E. Viassolo, and L. Xie, "Robust bidding strategy for wind power plants and energy storage in electricity markets," in *Proc. IEEE Power Energy Soc. Gen. Meet.*, San Diego, CA, Jul. 22-26, 2012, pp. 1-8. Copyright 2012, IEEE. (2) Reprinted with permission from A. A. Thatte, L. Xie, D. E. Viassolo and S. Singh, "Risk Measure based Robust Bidding Strategy for Arbitrage using a Wind Farm and Energy Storage," *IEEE Transactions on Smart Grid*, vol. 4, no. 4, pp. 2191-2199, Dec. 2013. Copyright 2013, IEEE.

wind generation.

Researchers have proposed techniques to coordinate the power output of wind generation with energy storage devices. Castronuovo and Lopes [8] consider a combined wind and pumped storage facility and determine the optimal operational strategy based on deterministic linear optimization for scenarios generated using a Monte Carlo simulation approach. The coordination of wind and flywheels for energy balancing and frequency regulation has been proposed in [1]. A dynamic programming algorithm for optimal scheduling of the combination of wind with a generic energy storage device is presented in [10]. Garcia-Gonzalez et al. [14] formulate the joint optimization of the wind and pumped storage facility as a two-stage stochastic programming problem. In fact there are many examples of the stochastic programming approach applied to power systems to deal with uncertainty [15, 13, 16]. However both the stochastic programming and dynamic programming approaches are computationally challenging due to the large number of scenarios that have to be considered.

Over the past few years Robust Optimization (RO) has been receiving increasing attention from researchers in electric power system operations to deal with uncertainty in optimization problems. The RO approach has been applied across a variety of domains including portfolio optimization, supply chain management, network flows, circuit design, wireless networks, and model parameter estimation [44]. In power systems recently the RO approach has been applied to the unit commitment problem [35]. In fact, over the past few years a number of researchers have proposed robust optimization approaches for unit commitment in power systems [37, 38, 39, 58].

The main feature of the RO approach is that it uses a *non-probabilistic* approach to deal with the uncertainty. Uncertainty is addressed by constructing an

uncertainty set and the solutions obtained are robust to all realizations of uncertain data within the defined uncertainty set. Such robustness is consistent with the reliability requirement of power systems operation, given that the cost associated with constraint violations is very high. Also, for a wide class of problems, the robust optimization models have similar computational complexity as the deterministic counterparts. This computational tractability makes robust optimization a practical approach for many real-world applications. The question that arises in this regard is as to the selection of these uncertainty sets. A commonly used approach to selecting the uncertainty set is based on the *budget of uncertainty* notion, which is used to control the conservatism of the solution [44]. Another method that has been suggested to determine the uncertainty set is to use risk measures commonly used in finance industry [5]. In financial portfolio optimization the future values of the assets are uncertain, similarly in the generator scheduling problem the market clearing price of electricity in the day-ahead market is uncertain at the time of generator bidding decision. The uncertainty set can be determined based on a coherent risk measure such as Conditional Value at Risk (CVaR) [30]. Consequently a robust optimization bidding strategy can be obtained based on the risk preference of the wind farm operator. Robust optimization solves for the *worst-case*, consequently it will yield conservative results if the forecast errors are low. However, since the robust approach yields solutions that are immunized to all realizations of uncertain data within the uncertainty set, it maybe a suitable approach when forecast errors are high.

The main contributions of this section are:

- presents the formulation for a robust optimization based bidding strategy for the combination of a wind farm and an energy storage device in deregulated electricity markets. By using energy arbitrage the wind farm operator can

leverage the on-site energy storage in order to get increased profit.

- analyzes and compares the performance of the robust optimization approach to the deterministic approach. The impact of the choice of uncertainty set on the optimality of the result is examined.
- verifies through a case study that the robust approach has a higher probability of yielding better economic returns compared to the deterministic optimization approach, for a high forecast error in day-ahead electricity market clearing price.
- compares the robust optimization based bidding strategy to a stochastic optimization based approach.
- proposes the use of risk measure based uncertainty sets for determining the optimal bids in the day-ahead electricity market. Risk measures used in finance industry can be used to incorporate decision maker's risk aversion in the decision making process.
- illustrates through case studies, the risk measure based robust bidding strategy for an energy arbitrage application using the combination of a wind farm and a generic energy storage.

3.2 Formulation

The bid scheduling for the combination of a wind farm and energy storage device is formulated as a linear optimization problem which aims to maximize the total profit from sale of electricity in the day ahead market. The aim of the energy arbitrage strategy is to leverage the storage to take advantage of temporal variations in the electricity price. This is done by storing energy from the wind farm in the storage

device when the price is low and then returning this energy to the grid when the price increases.

The inputs to the optimization are the forecasts of electricity prices and wind farm power production, whereas the outputs are the hourly power injection profiles of the wind farm and the energy storage for the entire operating day. The bids comprising of the hourly power injection totals of the wind farm and energy storage device are submitted to the market. Upon market clearing the system operator sends the dispatch signal comprising of successful injection bids, to the wind farm operator (Fig. 3.1). The wind farm and energy storage inject power to the grid to match the dispatch commands. The bidding strategy leverages the storage device by exploiting the arbitrage opportunities, created due to temporal price variations. The abbreviation *DKK* is used for Danish Kroner, and k is the index for the hours in the operating day. The nomenclature used is given in Table 3.1.

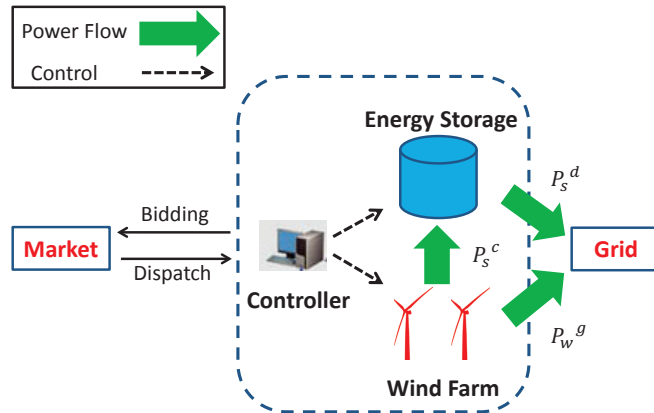

Figure 3.1: Schematic of wind farm and energy storage

Table 3.1: Nomenclature for bidding strategy

Decision Variables:

$P_w^g[k]$	Power injected by wind farm directly into the grid (MW)
$P_s^d[k]$	Discharge power of storage device (MW)
$P_s^c[k]$	Charge power of storage device (MW)
$E_s[k]$	Energy level of storage device (MWh)

Point Forecasts:

$\hat{P}_w[k]$	Forecast power production of wind farm (MW)
$\hat{\lambda}[k]$	Forecast market clearing price of electricity (DKK/MWh)

Random Variables:

$\tilde{P}_w[k]$	Power production of wind farm (MW)
$\tilde{\lambda}[k]$	Market clearing price of electricity (DKK/MWh)

Constants:

P_s^{max}	Rated power of storage device (MW)
E_s^{max}	Upper limit on energy level of storage device (MWh)
E_s^{min}	Lower limit on energy level of storage device (MWh)
η	Round-trip efficiency of the storage device (%)
η_d	Discharging efficiency of the storage device (%)
η_c	Charging efficiency of the storage device (%)
C_w	Marginal cost of wind (DKK/MW)
C_s	Charging/discharging (degradation) cost of storage (DKK/MW)
C_e	Energy storage operation cost (DKK/MWh)
P_w^r	Ramping constraint of wind farm (MW/h)
N	Number of time periods (for 1 day $N = 24$)

3.2.1 Deterministic Optimization Based Bidding Strategy

The objective function and constraints of the deterministic optimization problem are expressed as follows.

$$\begin{aligned}
 \min_{P_w[k], P_s^d[k], P_s^c[k], E_s[k]} & \sum_{k=1}^N [-\hat{\lambda}[k](P_w[k] + P_s^d[k] - P_s^c[k]) \\
 & + C_w P_w[k] + C_s(P_s^d[k] + P_s^c[k]) + C_e E_s[k]] \quad (3.1)
 \end{aligned}$$

s.t.

$$-P_w^r \leq P_w[k] - P_w[k-1] \leq P_w^r \quad (3.2)$$

$$0 \leq P_w[k] \leq \hat{P}_w[k] \quad (3.3)$$

$$E_s^{min} \leq E_s[k] \leq E_s^{max} \quad (3.4)$$

$$0 \leq P_s^c[k] \leq P_s^{max} \quad (3.5)$$

$$0 \leq P_s^d[k] \leq P_s^{max} \quad (3.6)$$

$$E_s[k] = E_s[k-1] - \frac{1}{\eta_d} P_s^d[k] + \eta_c P_s^c[k] - (\hat{P}_w[k] - P_w^g[k]) \quad (3.7)$$

The objective function (3.1) consists of (i) revenue from the sale of power from both the wind farm and storage, and (ii) various costs including the marginal cost of wind, degradation costs associated with charging and discharging, and energy storage costs. By minimizing the negative of the total profit, (3.1) effectively maximizes the total profit. The change in power output of the wind farm between consecutive time periods is subject to ramping up/down constraints (3.2). The amount of wind power directly injected into the grid can't exceed the forecast maximum wind power available (3.3). The amount of energy that can be stored in the storage device as well as its charging and discharging rate have certain upper and lower limits (3.4)-(3.6). The amount of energy in the storage device in any time period, depends on the charge/discharge history of the storage device, i.e. the storage dynamics, which are given by (3.7).

The model assumes that energy storage device can only be charged using wind power and not by the grid. This assumption is reflected in the equation for the storage dynamics (3.7). The term $\hat{P}_w(k) - P_w(k)$ in (3.7) is the firming power provided by storage to compensate for wind power forecast errors. The result of the optimization

is the total power to be sold in the Day Ahead Market (DAM) for each hour of the operating day.

$$\text{Bid}[k] = P_w[k] + P_s^d[k] - P_s^c[k], \text{ for } k = 1, 2, \dots, N. \quad (3.8)$$

3.2.2 Robust Optimization Based Bidding Strategy

Using the formulation described in Section 2 the robust optimization based strategy can be formulated as an extension to the deterministic optimization based strategy. Uncertainty exists in the amount of wind power and electricity price due to inaccuracy of forecasts. In such case the robust optimization problem can be stated as follows.

$$\begin{aligned} \min_{P_w^g[k], P_s^d[k], P_s^c[k], E_s[k]} \quad & \max_{\tilde{\lambda} \in \mathcal{U}, \tilde{P}_w \in \mathcal{V}} \sum_{k=1}^N [-\tilde{\lambda}[k](P_w^g[k] + P_s^d[k] - P_s^c[k]) \\ & + C_w P_w^g[k] + C_s(P_s^d[k] + P_s^c[k]) + C_e E_s[k]] \end{aligned} \quad (3.9)$$

s.t.

$$-P_w^r \leq P_w^g[k] - P_w^g[k-1] \leq P_w^r \quad (3.10)$$

$$0 \leq P_w^g[k] \leq \tilde{P}_w[k] \quad (3.11)$$

$$E_s^{\min} \leq E_s[k] \leq E_s^{\max} \quad (3.12)$$

$$0 \leq P_s^c[k] \leq P_s^{\max} \quad (3.13)$$

$$0 \leq P_s^d[k] \leq P_s^{\max} \quad (3.14)$$

$$E_s[k] = E_s[k-1] - \frac{1}{\eta_d} P_s^d[k] + \eta_c P_s^c[k] - (\tilde{P}_w[k] - P_w^g[k]) \quad (3.15)$$

where $\tilde{\lambda}$ is the uncertain electricity price variable, \tilde{P}_w is the uncertain available wind power, \mathcal{U} is the uncertainty set for electricity price, and \mathcal{V} is the uncertainty set for available wind power.

The dynamic equation for the storage device is (3.15). In the implementation code, in order to maintain tractability, this equality constraint is converted into two inequality constraints with small tolerances. The term $\tilde{P}_w[k] - P_w^g[k]$ is the firming power provided by storage to compensate for wind power forecast errors.

It is assumed that the storage device can only be charged using the wind power production and not by the grid (Fig. 3.1). This assumption is used since we are interested in analyzing the impact of storage on the utilization of wind resource. The power loss in storage charging and discharging is a function of η_d and η_c , the discharging and charging efficiencies of the storage device respectively. The roundtrip efficiency of the storage device can be taken as the product of these two values, i.e. $\eta = \eta_d \eta_c$.

3.2.3 Reformulation to Tractable Problem

In this subsection it is shown that using duality the min-max problem can be reformulated as a tractable linear programming problem.

The problem (3.9)-(3.15) is of the form

$$\begin{aligned}
 & \min \tilde{c}^T x \\
 & \text{s.t. } Ax \leq \tilde{b} \\
 & x \in X, c \in \mathcal{U}, b \in \mathcal{V}
 \end{aligned} \tag{3.16}$$

where x is the vector of decision variables, \tilde{b} and \tilde{c} are vectors of uncertain data. The

uncertain problem (3.16) can be reformulated as

$$\begin{aligned}
& \min t \\
& \text{s.t. } t - \tilde{c}^T x \leq 0 \\
& \quad Ax - \tilde{b}y \leq 0 \\
& x \in X, y = 1, c \in \mathcal{U}, b \in \mathcal{V}
\end{aligned} \tag{3.17}$$

When the uncertainty sets are polyhedral they can be represented by matrix inequalities. Thus (3.17) can be written in the min-max form as

$$\begin{aligned}
& \min f^T w \\
& \text{s.t. } \max g_i^T w \leq h_i \\
& \quad D_i g_i \leq d_i
\end{aligned} \tag{3.18}$$

where the symbols in (3.17) are assumed to be redefined with consistency maintained.

Taking the dual of the inner maximization subproblem in (3.18) we get

$$\begin{aligned}
& \min f^T w \\
& \text{s.t. } p_i^T d_i \leq h_i \\
& \quad p_i^T D_i = w \\
& \quad p_i \geq 0
\end{aligned} \tag{3.19}$$

Thus the original problem (3.9)-(3.15) is transformed into a tractable linear programming formulation.

3.2.4 Model Predictive Control Based Bidding Strategy

Model Predictive Control (MPC) is a receding horizon optimization based method which has been used in various process control applications [59]. In each iteration of the MPC an optimization problem based on a finite prediction horizon is solved to obtain an optimal control strategy. However only the first step of the control strategy is implemented and the remaining steps are discarded. New measurements are obtained and then the optimization is repeated. MPC has been proposed to solve the dispatch problem for power systems which have a high penetration of wind [60]. The use of MPC for the coordinated scheduling of wind farms and battery energy storage systems has been proposed [61]. Receding horizon control has been proposed for determining the real-time operation of a portfolio of storage devices [62].

The algorithm used by MPC method is as follows

1. Set iteration number $k = 1$.
2. Select the prediction horizon, N (e.g., 24 hours discretized into hourly intervals)
3. Solve the deterministic linear optimization problem (3.1-3.7) for the entire horizon from k to $k + N - 1$ and get optimal decision U^* . We have $U^* = [u_1^*, u_2^*, \dots, u_N^*]$, where $u_k^* = [P_w(k), P_s^d(k), P_s^c(k), E_s(k)]$.
4. Use the first element of U to make the bidding decision for the wind farm and storage device.
5. Set $k = k + 1$ and update information (wind forecast, price forecast, constraints etc.). Goto step 2.

The MPC method is applicable only for certain market structure. For example, in the hour ahead market over the duration of one day 24 hourly bids are to be

submitted one hour ahead of each operating hour, and thus the forecasts of wind power and electricity price can be updated as the operating day progresses. Whereas in the day-ahead market the bids for all the 24 hours have to be submitted at the same time, hence MPC approach can not be used. Thus MPC is suitable for hour-ahead or real-time markets where bids in each market time interval are submitted individually at different times, rather than collectively at the same time.

3.3 Numerical Examples

A numerical example is considered in order to compare the performance of the robust optimization approach with the deterministic optimization approach. These approaches are applied for determining the optimal bidding strategy of the wind farm and storage device combination, for the energy arbitrage application. The characteristics of the wind farm and a generic energy storage device are presented in Table 3.2.

Table 3.2: Wind farm and storage device parameters

\tilde{P}_w^{max}	Rated capacity of wind farm (MW)	30
P_s^{max}	Rated capacity of storage device (MW)	3
E_s^{max}	Maximum energy level of storage device (MWh)	3.75
η	Round trip efficiency of storage	90%
η_d	Discharging efficiency of storage	95%
η_c	Charging efficiency of storage	95%
C_w	Marginal cost of wind (DKK/MW)	5
C_s	Charging discharging (degradation) cost (DKK/MW)	1.5
C_e	Energy storage cost (DKK/MWh)	1

Electricity price data from Nordpool for West Denmark is used for the simulations. The hourly bids for sale and purchase of energy in the day ahead market for the entire operating day have to be submitted on the previous day, 12 hours before

the beginning of the operating day (Fig. 3.2). It is assumed that any excess wind generation is sold in the hour-ahead market whereas any deficit has to be purchased from the hour-ahead market at the hour-ahead market price. The decision for the wind farm and storage device hourly power output profile is made based on forecasts of the day-ahead electricity price and wind power. The profit is calculated based on the actual values of price and wind. This settlement is done after the end of the operating day. The robust optimization problem is solved using MATLAB along with the YALMIP toolbox [63].

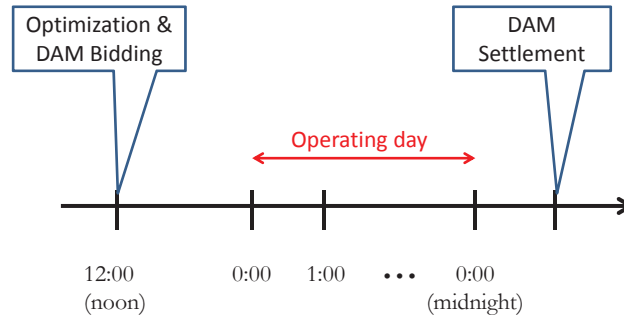

Figure 3.2: Nordpool market timeline

3.3.1 Day Ahead Market - One Day (*Deterministic vs. Robust*)

In order to analyze the performance of the optimization based bidding strategy Monte Carlo simulation method is used. The Cauchy distribution is taken as the model for the distribution of wind power forecast errors [64]. For electricity price forecast error again Cauchy distribution has been shown to be a reasonable model [65]. Thus for both the wind farm power output and the electricity price an error is generated at random for each hour of the day by sampling a Cauchy distribution

within bounds defined by 90% confidence interval. For each hour of the day the realization of the actual value of the input quantity (i.e., wind farm power output and electricity price) is obtained by subtracting the error from the forecast value. Thus $M=100$ scenarios of actual wind farm power output and electricity price are generated using random sampling.

Two particular scenarios are shown for comparing the performance of robust optimization to deterministic optimization. In Scenario A the forecast error is high whereas in Scenario B the forecast error is low.

3.3.1.1 Scenario A

Fig. 3.3 shows the hourly electricity prices in the day-ahead market for Scenario A. The error between forecast and actual price is high, particularly for hour 17 and 21. Fig. 3.4 shows the bidding decision for wind and storage for the given day. In hours 2-5 when the forecast price is lower, part of the wind energy is used to charge the storage device. In hour 11 when the forecast price reaches its peak the stored energy is injected into the grid. Thus the storage device can be used to take advantage of arbitrage opportunities that result from temporal variations in the electricity price. Fig. 3.5 shows the bidding decision using the robust optimization approach. In this scenario total profit from the wind farm and storage combination for the deterministic approach is *DKK* 25,241.12 whereas the total profit for the robust approach is *DKK* 25,341.50. Thus the economic performance of the robust approach is higher than deterministic by 0.398% for this particular scenario.

3.3.1.2 Scenario B

Fig. 3.6 shows the hourly electricity prices in the day-ahead market for Scenario B. Compared to Scenario A the actual electricity prices are closer to the forecast. Fig. 3.7 and Fig. 3.8 show the bidding decisions for wind and storage using the

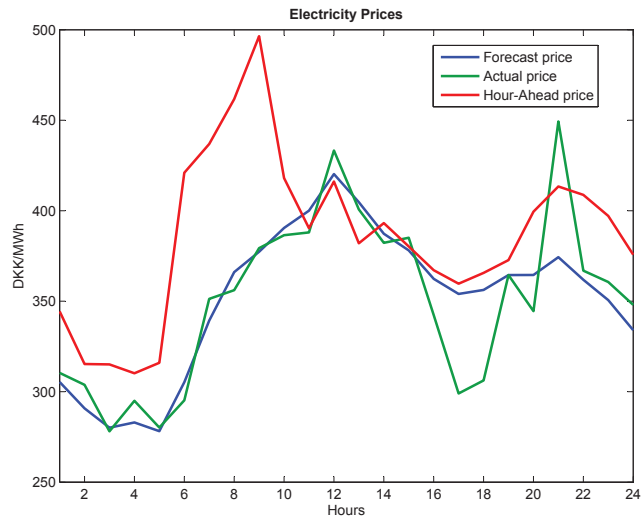

Figure 3.3: Electricity prices for scenario A

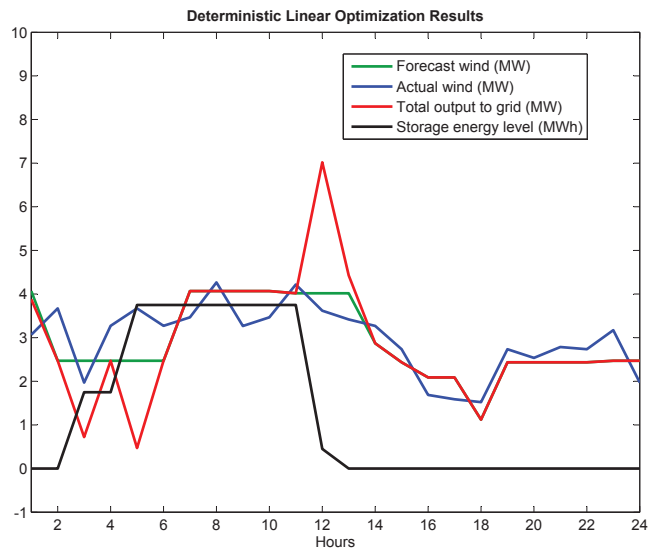

Figure 3.4: Results of deterministic optimization scenario A

deterministic and the robust optimization approach respectively. In this scenario since the electricity price forecast error is smaller than Scenario A, particularly for the key time intervals, hours 17 and 21 when the storage charges and discharges,

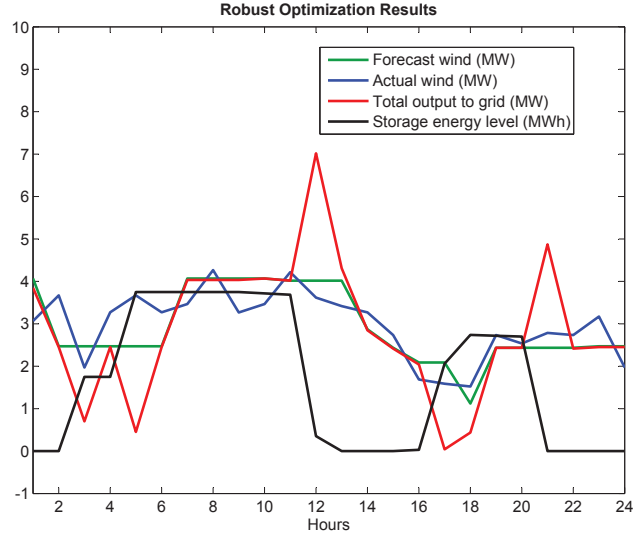

Figure 3.5: Results of robust optimization for scenario A

the robust optimization gives a more conservative result than the deterministic optimization. In this scenario total profit from the wind farm and storage combination for the deterministic approach is *DKK* 25,083.42 whereas the total profit for the robust approach is *DKK* 24,977.59. Thus the economic performance of the robust approach is lower than deterministic approach by 0.422% for this particular scenario.

3.3.1.3 Impact of Choice of Uncertainty Set

The performance of the robust optimization approach as a function of the budget of uncertainty (Γ) is analyzed. Historical true values and forecasts of electricity price for past seven days are used to estimate the variance and standard deviation (σ) of the hourly prices for the given day, using the approach presented in [45]. Information about the variance of the uncertain coefficients is used to construct polyhedral uncertainty sets for electricity price and wind power as follows.

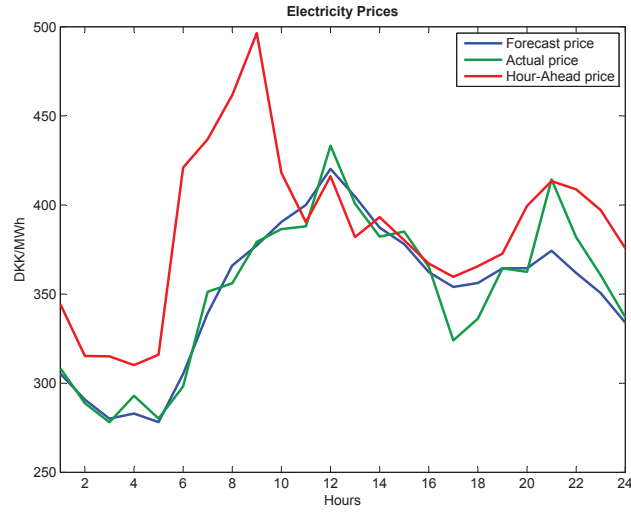

Figure 3.6: Electricity prices for scenario B

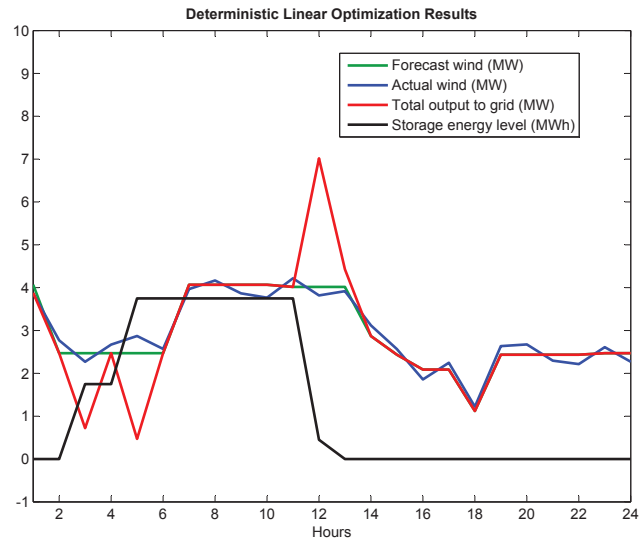

Figure 3.7: Results of deterministic optimization for scenario B

The polyhedral uncertainty set is defined as

$$\mathcal{U} = \left\{ \tilde{a}_i \mid \sum_{i=1}^n \frac{|\tilde{a}_i - \hat{a}_i|}{\sigma_i} \leq \Gamma \right\} \quad (3.20)$$

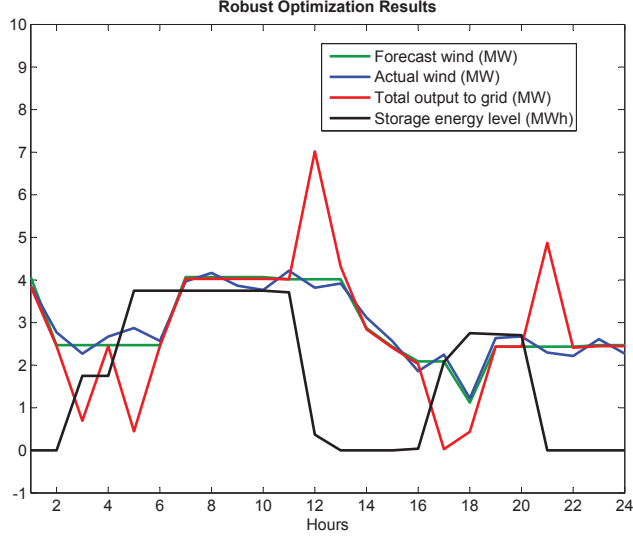

Figure 3.8: Results of robust optimization for scenario B

where $|\tilde{a}_i - \hat{a}_i| = |\Delta a_i| = |\alpha \hat{a}_i|$, α being a scalar constant in the set $[0, 1]$ which gives the relation of the deviation Δa_i to the nominal value \hat{a}_i . σ_i is the standard deviation of coefficient a_i and Γ is the *budget of uncertainty* which is used to adjust the level of conservatism of the solution [46].

The uncertainty sets are chosen as follows.

$$\mathcal{U} = [(1 - \alpha_p)\hat{\lambda}, (1 + \alpha_p)\hat{\lambda}] \quad (3.21)$$

$$\mathcal{V} = [(1 - \alpha_w)\hat{P}_w, (1 + \alpha_w)\hat{P}_w] \quad (3.22)$$

where \mathcal{U} is the uncertainty set for electricity price, \mathcal{V} is the uncertainty set for available wind power, and α_p and α_w are the scalar parameters that define the respective uncertainty sets.

Thus for each value of Γ using (3.20) the corresponding value of α_p is obtained. Then using the electricity price forecast and wind power forecast as the nominal

values their respective uncertainty sets can be obtained.

The mean total profit of the day using the deterministic and robust optimization approach for the 100 scenarios is calculated. The worst case realization profit is also calculated for each case. Table 3.3 illustrates how the result is affected as the budget of uncertainty for price increases. The uncertainty set for wind power is fixed and is based on $\alpha_w = 0.01$

Table 3.3: Results of Monte Carlo runs (DO: deterministic optimization, RO: robust optimization, result = mean daily total profit, change = % change relative to DO case, WC = worst case realization profit)

	Γ	α_p	Result (DKK)	Change %	WC (DKK)
DO	-	-	30,750	-	26,413
RO	0	0	30,750	0	26,170
	5	0.01	30,512	-0.77	26,170
	10	0.02	30,511	-0.77	26,169
	15	0.03	30,454	-0.96	26,093
	20	0.04	30,373	-1.22	26,019
	25	0.05	29,664	-3.53	25,346
	30	0.06	29,661	-3.54	25,338
	35	0.07	29,661	-3.54	25,350
	40	0.08	29,661	-3.54	25,350
	45	0.09	29,636	-3.62	25,304
	50	0.1	29,636	-3.62	25,304

It is observed that as the budget of uncertainty increases the performance of robust optimization becomes more and more conservative in terms of the mean daily total profit. Also, increasing Γ above 25 has only a small impact on the optimality of result. The result of robust optimization for each case is better than the worst case realization.

3.3.2 Day Ahead Market - Many Days (Deterministic vs. Robust)

In this case the robust optimization algorithm is used for determining the bidding strategy for 90 consecutive days. Fig. 3.9 shows the electricity price forecast and actual data for the first 10 days. Fig. 3.10 shows the wind power output forecast and actual values for the same time period. The mean daily total profit of the robust optimization approach is calculated for different choices of price uncertainty bounds and wind uncertainty bounds.

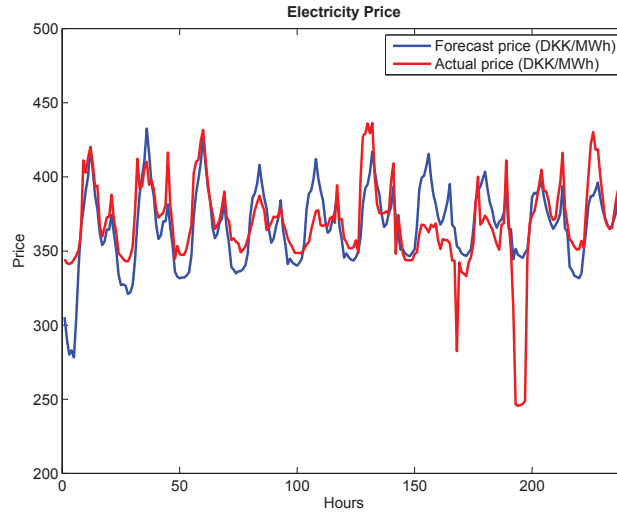

Figure 3.9: Forecast and actual electricity price for 10 days

Table 3.4 shows the relationship of the mean daily total profit over 90 days to the parameter α_w which determines the uncertainty set for wind.

Table 3.5 shows the relationship of the mean daily total profit over 90 days to the parameter α_p which determines the uncertainty set for price. As we observe, the mean daily total profit is more sensitive to the choice of wind uncertainty set than

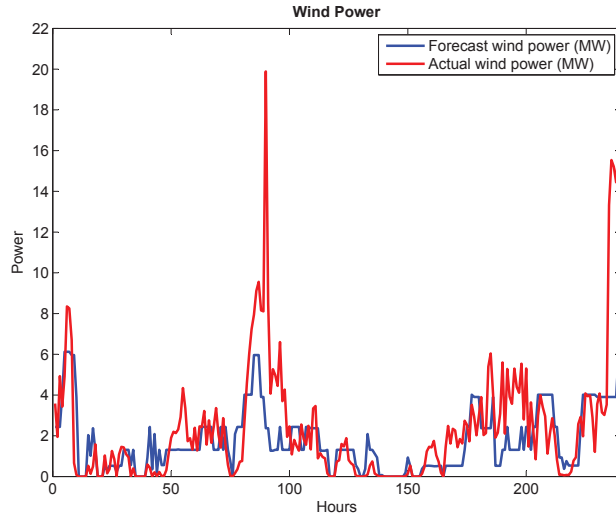

Figure 3.10: Forecast and actual wind farm power output for 10 days

Table 3.4: Impact of choice of uncertainty set of wind power

$\alpha_p = 0.01$			
α_w	Mean Daily Total Profit (DKK)	% Change	
0 (Det)	70,847	0	
0.005	70,633	-0.302	
0.01	70,419	-0.604	
0.02	69,990	-1.210	
0.03	69,555	-1.824	
0.04	69,112	-2.449	

price uncertainty in this particular case.

3.3.3 Hour Ahead Market - One Day (Robust vs. MPC)

The robust optimization approach is compared to the MPC based optimization approach. In this case study MPC uses a receding look ahead horizon of 24 hours and the wind forecast is updated every 6 hours. It is assumed that when the actual wind farm power output is less than the bid to the market the deficit has to be purchased

Table 3.5: Impact of choice of uncertainty set of price

$\alpha_w = 0.01$			
α_p	Mean Daily	Total Profit (DKK)	% Change
0 (Det)		70,847	0
0.005		70,420	-0.603
0.01		70,419	-0.604
0.02		70,412	-0.614
0.03		70,406	-0.622
0.04		70,388	-0.648

from the balancing market at regulation-up price, which is usually higher than the spot market price. Whereas when the actual wind power exceeds the bid, the excess is sold at regulation-down price, which in most hours is lower than the spot market price or sometimes may even be negative. Thus by means of a lower total profit the wind farm is effectively penalized for deviations of actual wind production from the bid.

The hour-ahead energy forecast and actual price, as well as the regulation market prices are shown in Fig. 3.11.

Fig. 3.12 shows the hourly bids using the robust optimization with uncertainty in available wind power and electricity price for the hour-ahead market for one day. Fig. 3.13 shows the hourly bids using the MPC based optimization. The curve for the forecast wind power for 24 hours in Fig. 3.13 is comprised of the first 6 hours of the forecast in each of the 4 iterations of the MPC. The total profit using the robust optimization approach is *DKK* 43,367 whereas the MPC approach yields *DKK* 45,294, an increase of 4.44%.

3.4 Decision Making Process for Wind Farm Operator

In this subsection the decision making process from the perspective of a price taking wind farm operator for participating in the day ahead electricity market is

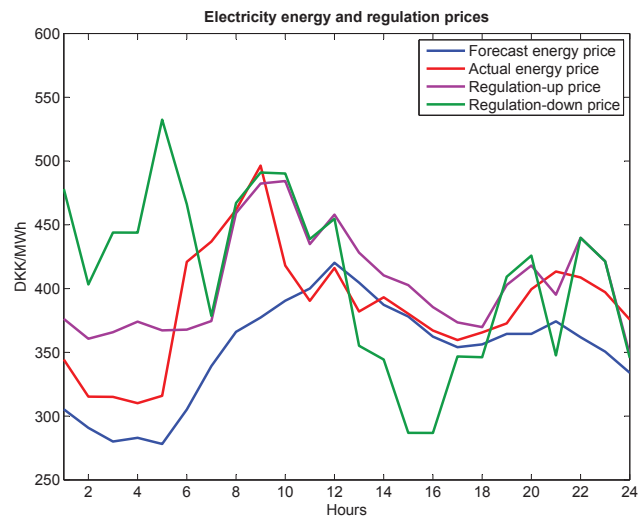

Figure 3.11: Hour ahead energy and regulation prices

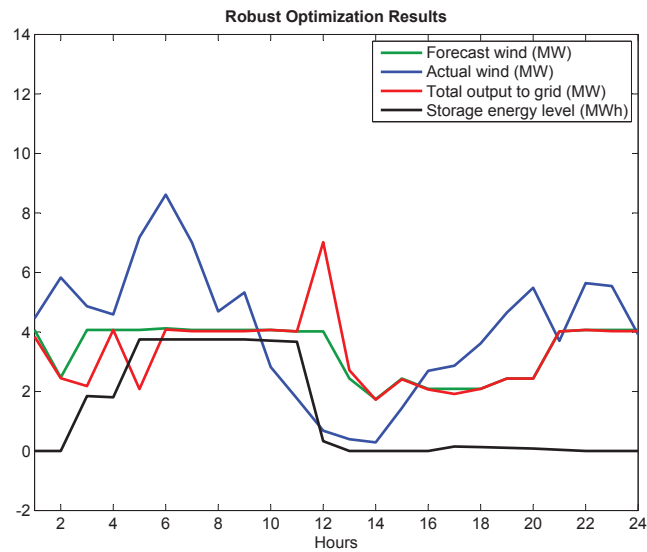

Figure 3.12: Results of robust optimization: hour-ahead market

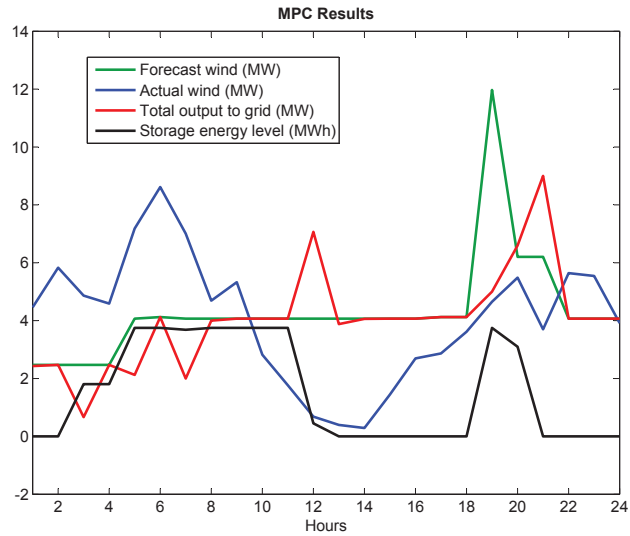

Figure 3.13: Results of MPC optimization: hour-ahead market

discussed.

3.4.1 Decision Making Algorithm and Flowchart

An *offline* decision making process is proposed to choose the optimization model based on Monte Carlo simulation which makes use of historical data on the uncertain variables, followed by an *online* decision which uses the chosen optimization model and the forecasts of wind power and electricity price to yield the bidding strategy. The flowchart for this decision making process is shown in Fig. 3.14.

1. It is assumed that historical data on wind power forecast error and electricity price forecast error is available to the decision maker. This data can be used to estimate the type of probability distribution in forecast error and the worst case of uncertainty that may be experienced by the wind farm operator.
2. Next the performance of the optimization based bidding for multiple values of the parameter β are compared using Monte Carlo simulation. The considered

optimization models may range from deterministic ($\beta = 0\%$) to *worst-case* robust ($\beta = 100\%$). Based on the profits obtained in the Monte Carlo runs CVaR can be estimated for each model in order to compare their performance.

3. The decision maker selects the optimization model based on both the relative performance as obtained from Monte Carlo simulations as well as the decision maker's confidence in the forecast. The decision maker may use historical data on forecast error to decide the confidence level in a given forecasting method. If the decision maker has a high level of confidence in the forecast it may not make sense to use a more robust approach since it would be too conservative. However, if the decision maker believes that the price forecast error is likely to be high, choosing a more robust approach, i.e., a higher value of β may be appropriate. A risk averse decision maker may choose a more robust approach even when the price forecast error is anticipated to be medium, in order to minimize potential loss of revenue in case the actual price forecast error is higher than anticipated. The uncertainty set associated with the particular choice of β can be obtained.
4. Once the optimization model is chosen the decision maker can use the optimization model to determine the optimum bidding strategy. The uncertainty set for wind power can be selected based on probabilistic forecasts.

Thus the optimization based bidding strategy for the combination of wind farm and energy storage can be obtained.

3.4.2 Dashboard Tool for Bidding Strategy Selection

In order to facilitate bidding strategy selection a software tool with a dashboard GUI is proposed (Fig. 3.15). This software tool would allow the decision maker to use

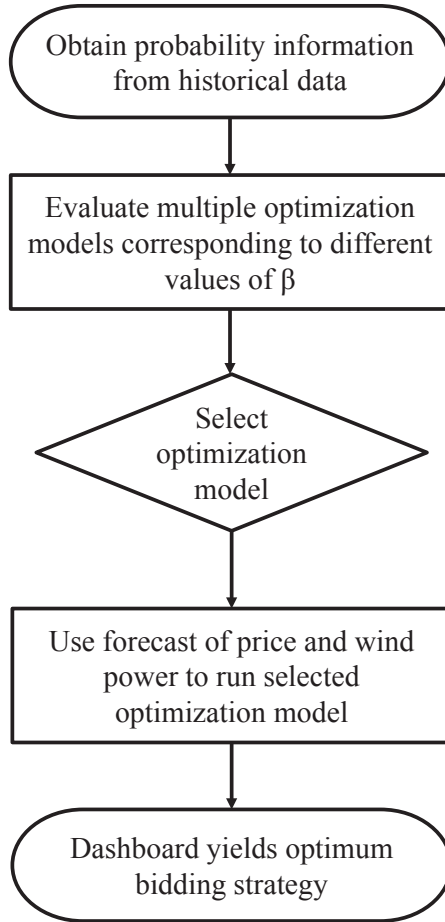

Figure 3.14: Flowchart for wind farm operator decision making

historical data in an *offline* study to estimate the type of probability distribution of the forecast error as well as the worst case of uncertainty that the wind farm operator may experience. The tool can then compare the performance of the optimization model for different values of the parameter β , based on Monte Carlo simulation, and determine the uncertainty set. Thus the uncertainty set can be selected through an offline process. Next in the online phase the optimization routine can be run to determine the bidding strategy for the wind farm and energy storage device for the day-ahead electricity market. The inputs are the wind power forecast and electricity

price forecast for the operating day.

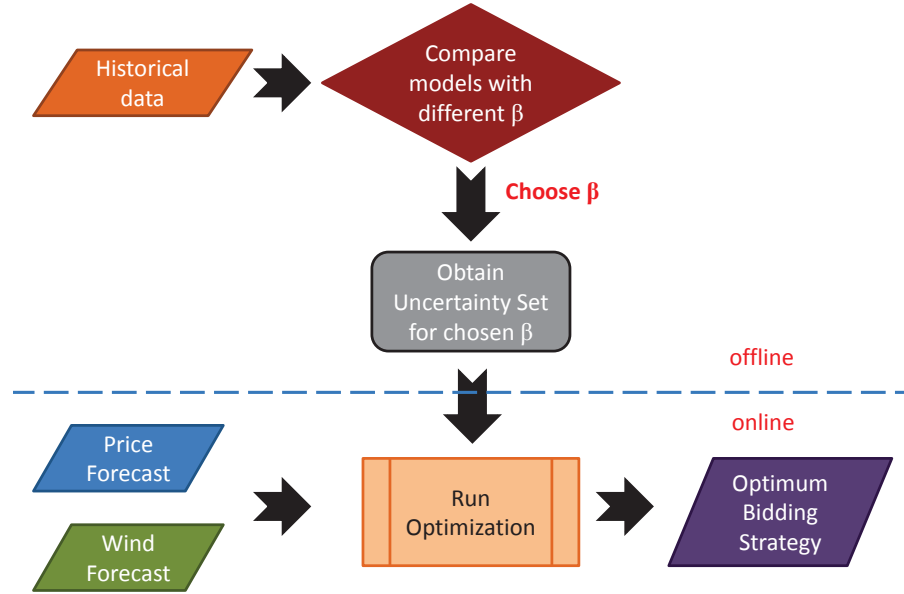

Figure 3.15: Proposed dashboard for bidding strategy selection

3.5 Performance of Robust Bidding Strategy

In this subsection a case study is presented in which the economic performance of the robust optimization based bidding strategy is evaluated. For simplicity it is assumed that all the hourly bids submitted by wind farm and energy storage combination to the market operator are successful. The characteristics of the wind farm and a generic energy storage device are presented in Table 3.2.

The result of the robust optimization based bidding problem presented earlier gives the power injection profile for the wind farm and storage device for each hour of the entire operating day. Based on these injection profiles the bids, which are the hour-by-hour total power injection of the wind farm and energy storage combination,

are obtained. The bids for the Day-Ahead electricity market (DAM) have to be submitted 12 hours before the beginning of the operating day (Fig. 3.2). Electricity price data from Nordpool for West Denmark is used for the simulations. The data used in this case study was provided by Vestas. It is assumed that during actual operation any excess wind generation is sold in the Hour-Ahead market, whereas any deficit has to be purchased from the Hour-Ahead market at the clearing price for that hour. The total profit from electricity sales is calculated based on the actual values of market clearing price. This settlement is done after the end of the operating day. The robust optimization problem is implemented and solved in MATLAB using *linprog* solver and the YALMIP toolbox [63].

In order to analyze the performance of the optimization based bidding strategy, Monte Carlo simulation method is used for a *what-if* type analysis based on assumptions about forecast errors. The Cauchy distribution is considered to be a reasonable model for the distribution of wind power forecast error [64] and electricity price forecast error [65]. Based on historical data consisting of 3 months of hourly forecasts and actual values of market clearing price and wind power, we also find that using Cauchy distribution to model the errors is a reasonable assumption (Fig. 3.16 and Fig. 3.17). Therefore for both the wind farm power production and the electricity price an error is generated at random for each hour of the day by sampling a Cauchy distribution within bounds defined by 90% confidence interval. For each hour of the day the realization of the actual value of the input quantity (i.e., wind farm power production and electricity price) is obtained by subtracting the error from the forecast value. In this manner $M=1000$ scenarios of actual wind farm power production and electricity price are generated for the given day using random sampling. For each scenario based on the bids obtained from the robust optimization the profit for the operating day can be calculated. These 1000 values are assumed to be indepen-

dent identically distributed (i.i.d.) observations of the profit. Based on the order statistics, the VaR and the CVaR can be estimated from these observations [66].

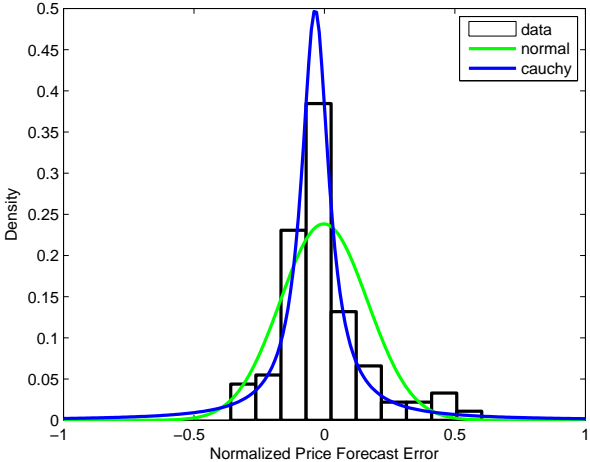

Figure 3.16: Histogram of normalized price forecast error

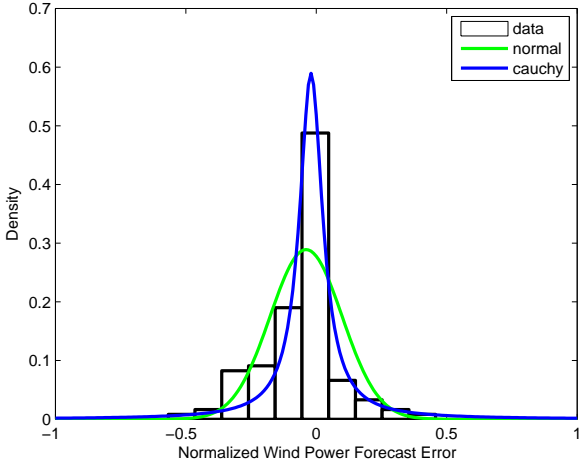

Figure 3.17: Histogram of normalized wind power forecast error

3.5.1 Relative Performance of Robust Bidding

In this case study the robust bidding strategy is analyzed for one operating day. The performance of the robust optimization bidding strategy relative to the deterministic approach is analyzed for different levels of electricity price forecast error. The deterministic model uses the point forecasts of the inputs in the optimization to find the bid schedule [67]. Both the robust and deterministic optimization based strategies are obtained for a set of price forecasts with error measured in Mean Absolute Error (MAE). MAE is the unweighted average of the absolute values of the forecast errors.

$$\text{Mean Absolute Error (MAE)} = \frac{1}{n} \sum_{i=1}^n |\hat{y}_i - y_i|$$

where \hat{y}_i is the forecast value, y_i is the actual value and n is the number of samples.

To evaluate the performance of each bidding strategy Monte Carlo simulation is used. A number of scenarios of actual electricity price (1000 scenarios) are considered. The result we are interested in is the number of scenarios where the profit from robust optimization (RO) based bidding strategy is greater than that from the deterministic optimization (DO) based bidding strategy. The results for several days are analyzed (Fig. 3.18). In all the cases for an increase in price forecast error there is a corresponding increase in the probability of getting better results using robust optimization compared to using deterministic optimization.

It has been observed that day-ahead wind power forecast error as a percentage of installed capacity has MAE in the range of 15% – 25% for a single wind farm [68, 69]. Wind farms that want to bid into day-ahead market have a serious problem of dealing with the uncertainty due to high wind power production forecast errors. Further the electricity price forecast for the day ahead time horizon can have an error

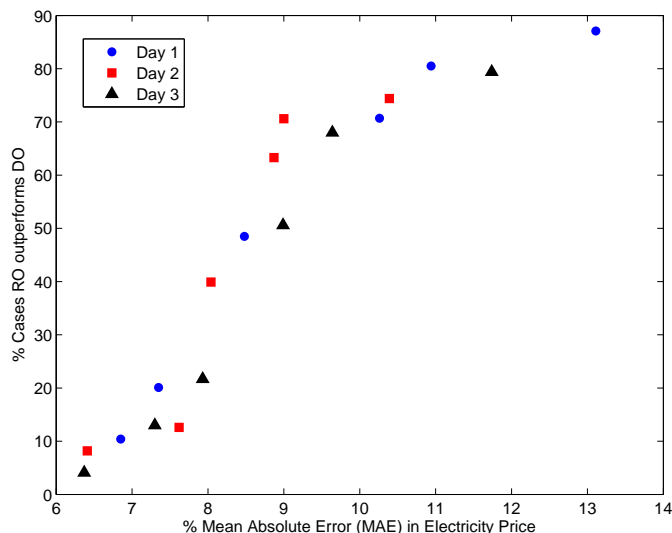

Figure 3.18: Relative performance of robust optimization based bidding vs. price forecast error

of up to around 15% [70]. The robust optimization approach can be used to manage the uncertainty due to high day-ahead forecast error, and obtain better economic performance compared to the deterministic optimization approach.

3.5.2 Performance Guarantee

Bertsimas et al. [46, 71] address the issue of the performance guarantee of the robust optimization model versus the budget of uncertainty. Based on their approach we consider the problem (3.17) and assume that each of the n elements of the vector of uncertain cost coefficients \tilde{c} belongs to a symmetric interval $[\bar{c}_i - \hat{c}_i, \bar{c}_i + \hat{c}_i]$ centered at the point forecast value \bar{c}_i with maximum deviation \hat{c}_i . The parameter $\Gamma \in [0, n]$ is defined by $\sum_{i=1}^n |(\tilde{c}_i - \bar{c}_i)/\hat{c}_i| \leq \Gamma$, and is called the *budget of uncertainty* of the cost coefficients. Γ is the upper bound of the aggregate scaled deviations of the actual values of the coefficients from their point forecast values, and thus can be used to represent the accuracy of forecasting. The key result from [46] can be summarized

as follows. For the robust optimization problem let x^* be an optimal solution and t^* the optimal objective function value, then $Pr(\tilde{c}^T x^* < t^*) \leq \epsilon$ if Γ is chosen to be $1 + \Phi^{-1}(1 - \epsilon)\sqrt{n}$, where $\epsilon \in (0, 1)$, n is the number of uncertain variables (here $n = 24$ hours since we consider one day) and Φ is the cumulative distribution function of the standard Gaussian random variable. Thus the actual value of the profit from bidding will exceed the predicted value with probability at least equal to $1 - \epsilon$, and this value is the performance guarantee. Fig. 3.19 shows the theoretical performance guarantee of the robust optimization model, under above assumptions on uncertainty in coefficients, for different values of the budget of uncertainty [71].

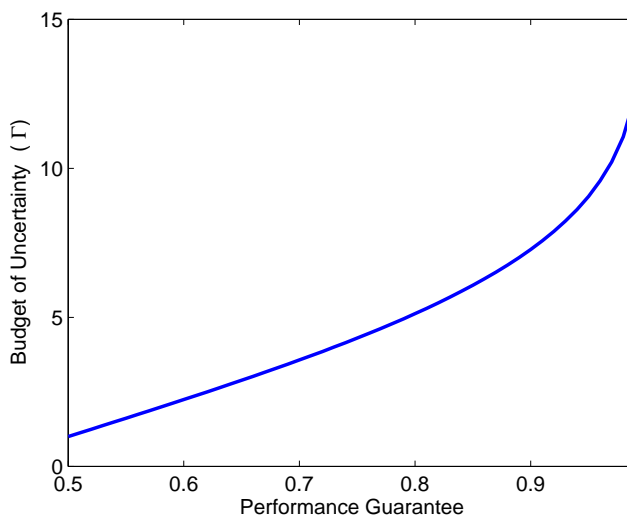

Figure 3.19: Performance guarantee of robust optimization model

3.6 Case Studies

In these case studies the robust bidding strategy is analyzed for one operating day.

3.6.1 Case 1: Modulated Convex Hull Based Uncertainty Set

Fig. 3.20 shows the forecast and actual hourly electricity prices for the day-ahead market, as well as the actual prices in the hour-ahead market for the given day. The error between forecast and actual day-ahead price is high in hours 17 and 21.

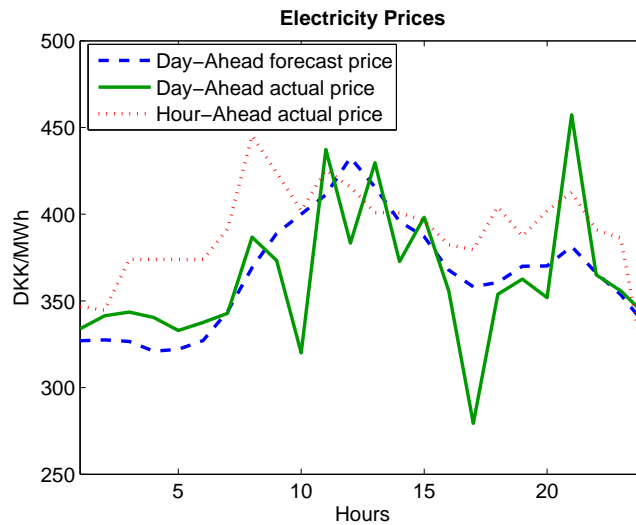

Figure 3.20: Electricity prices for given day (Case 1)

First the results are presented using the uncertainty set defined based on choice of parameter ϵ . Table 3.6 shows the results for different uncertainty sets based on parameter ϵ . Based on these results it is seen that the 95% CVaR is maximum for $\epsilon = 0.93$. The corresponding robust bidding strategy for the combination of the wind farm and storage (with one particular realization of actual wind) is shown in Fig. 3.21.

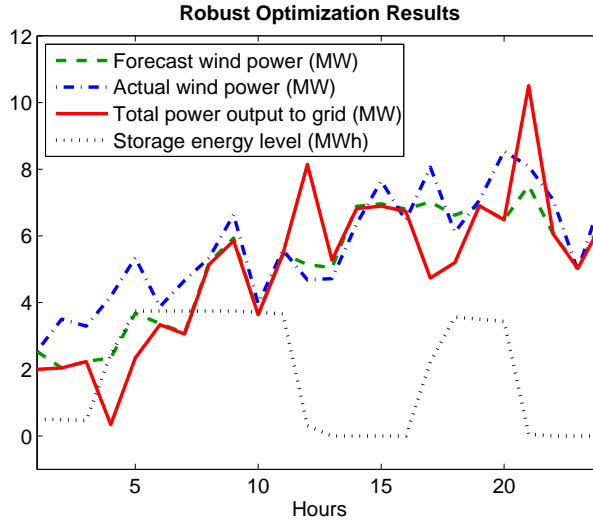

Figure 3.21: Results for $\epsilon = 0.93$

Table 3.6: Results of Monte Carlo simulation for different ϵ

Uncertainty Set for Price (ϵ)	95% VaR (DKK)	95% CVaR (DKK)	Mean Profit (DKK)
0.95	47,632	46,873	50,891
0.94	47,727	46,962	50,983
0.93	47,728	46,964	50,982
0.92	47,708	46,954	50,972
0.91	47,703	46,949	50,966
0.90	47,708	46,948	50,964

3.6.2 Case 2: Risk Measure Based Uncertainty Set

Next we use the uncertainty set constructed based on CVaR risk measure and decision maker's choice of risk parameter β . Fig. 3.22 shows the forecast and actual hourly electricity prices for the day-ahead market. Table 3.7 shows the results of the evaluation of the robust bidding strategy using Monte Carlo simulation, for different uncertainty sets based on wind farm operator's choice of parameter β . Table 3.8 shows the 95% CVaR values for different uncertainty sets and forecast errors in

prices measured in MAE%. The robust bidding strategy for the combination of the wind farm and storage corresponding to $\beta = 10\%$ and MAE=7.34% is shown in Fig. 3.23. In hours 3-5 when the forecast price is low, part of the wind energy is used to charge the storage device. In hour 11 when the forecast price is high the stored energy is injected into the grid. Therefore the storage device can be used to take advantage of arbitrage opportunities that result from temporal variations in the electricity price.

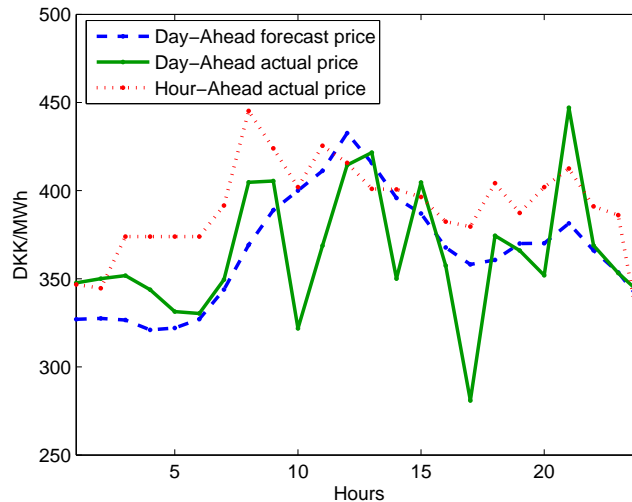

Figure 3.22: Electricity prices for given day (Case 2)

The simulation is conducted on a laptop with Intel Core 2 Duo 2.2 GHz CPU with 4 GB of RAM. It takes 13.3 seconds to generate the Monte Carlo scenarios. For each value of β the robust optimization and evaluation takes on average 7.2 seconds.

In order to determine uncertainty sets for wind power production around the deterministic forecast we use probabilistic forecasts. Percentiles of a probabilistic forecast are usually defined such that the probability of wind power production being

Table 3.7: Results of Monte Carlo simulation for different β

Uncertainty Set for Price (β)	95% VaR (DKK)	95% CVaR (DKK)	Mean Profit (DKK)
20%	47,692	46,958	50,775
10%	47,693	46,958	50,775
5%	47,692	46,959	50,776
2%	47,692	46,959	50,776
1%	47,675	46,960	50,776

Table 3.8: CVaR for combinations of β and MAE

95% CVaR (DKK)			
MAE (%)	$\beta=10\%$	$\beta=5\%$	$\beta=1\%$
7.34	46,958	46,959	46,960
8.35	47,000	47,001	47,003
10.26	47,077	47,078	47,078
10.93	47,267	47,268	47,269

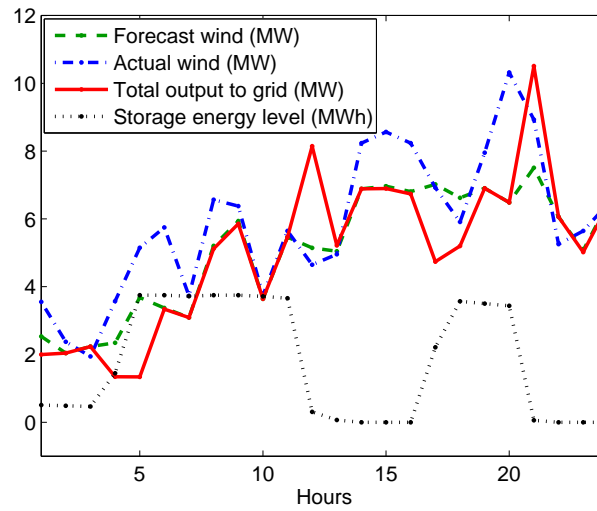

Figure 3.23: Results of robust optimization for $\beta = 10\%$

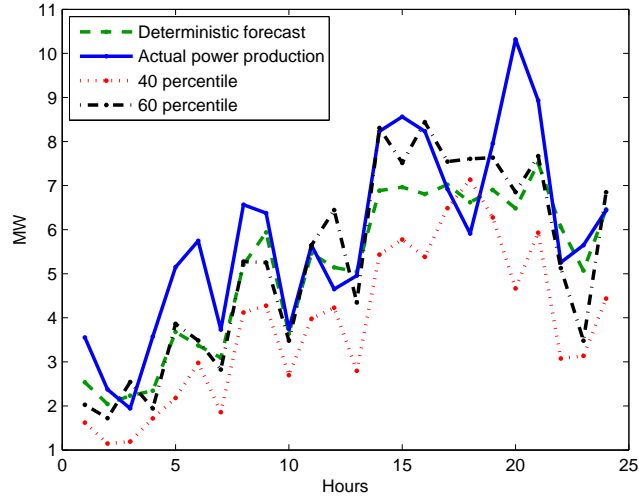

Figure 3.24: Wind deterministic and percentile forecast

less than the value given by the θ percentile forecast is θ percent [72]. Fig. 3.24 shows the deterministic forecast, actual wind power production, and the probabilistic forecasts for 40 and 60 percentiles for the given day. Pairs of probabilistic forecasts are taken as the lower and upper bounds for the uncertainty set for wind power. Table 3.9 shows the results of the Monte Carlo simulation, with different uncertainty sets for wind power, based on pairs of probabilistic forecasts. Thus the optimal robust bidding strategy is obtained which considers uncertainty in both electricity price and wind power (Fig. 3.25).

3.6.3 Comparison to Stochastic Programming

Finally we present a comparison of the robust optimization approach to the stochastic optimization approach. For the stochastic model we solve the expected value problem using the sample average approximation method [3]. This involves solving a large deterministic problem using the Monte Carlo method. With $N_s=100$

Table 3.9: Results of Monte Carlo simulation for wind uncertainty sets

Uncertainty Set for Wind (percentile bands)	95% VaR (DKK)	95% CVaR (DKK)	Mean Profit (DKK)
40% – 60%	44,581	43,865	47,641
30% – 70%	41,249	40,507	44,249
20% – 80%	36,012	35,300	38,982

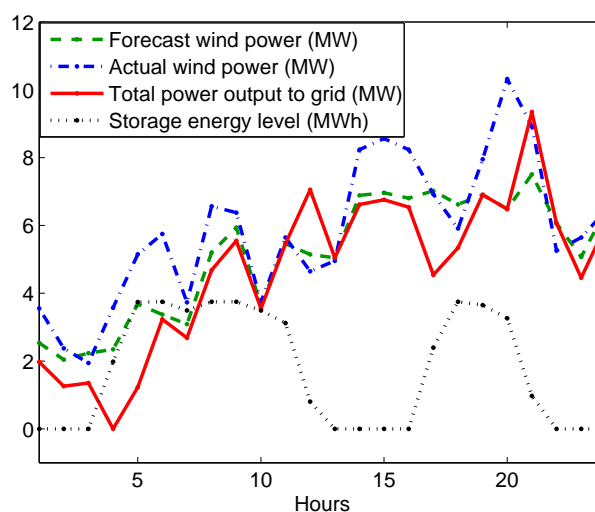

Figure 3.25: Results of robust optimization for $\beta = 10\%$ (price) and 40% – 60% (wind)

samples the stochastic approach yields a mean profit of DKK 51,164 and takes 714.2s to solve. Whereas the robust approach yields a mean profit of DKK 50,775 and takes 20.4s to solve. The problem size of the stochastic approach increases linearly with N_s and the computation time would be very large for a large sample size, whereas, the robust approach is comparable to the deterministic in computational effort required.

3.7 Joint Bidding in Energy and Regulation Markets

Grid frequency control is an essential operation in power systems, which essentially involves matching supply to demand so as to maintain the system frequency close to the nominal value. This is a challenge given that load varies over time. Further, generators may also deviate from their schedule, and in particular for wind generators the output varies due to variations in wind speed. Normally conventional generators provide capacity for frequency regulation, which is utilized through AGC control. Given the increasing penetration of variable renewable generation from sources such as wind and solar it is believed that the amount of regulation reserves will also have to increase [73].

Modern power electronics based controllers allow wind generators to participate in frequency control action [74]. Wind farms can provide regulation by curtailing energy production to create head room for regulation up service. For a wind generator to participate in the regulation market it has to reduce its participation in the energy market. However, under certain market conditions, the price of regulation service more than makes up for the lost opportunity cost. Thus it could be profitable for a wind generator to participate in the regulation market. The regulation market is a capacity market and the wind generator has to assure the system operator that it can provide the required service when the system needs it. This is difficult given the wind forecast inaccuracy. Hence we consider the case where an on-site storage facility is available that can be coordinated with the wind generator in order to provide firm capacity.

The question of the extent to which wind generator should participate in the energy versus the regulation markets can be formulated as an optimization problem. The objective is to maximize profits by exploiting price differences between the elec-

tricity spot market and the frequency regulation capacity market. The decision to be made in each period k is to choose the amount of wind energy to be sold into the energy market versus bidding into the regulation capacity market. The decision for the amount of regulation capacity that can be sold by the storage device depends on the extent to which wind bids into the regulation market in the same time period. The nomenclature used is given in Table 3.10.

Table 3.10: Nomenclature for joint energy and frequency regulation bidding

Decision Variables:

$P_w[k]$	Power injection from wind farm to the grid (MW)
$P_w^{ru}[k], P_w^{rd}[k]$	Reg-up and Reg-down capacity from wind farm (MW)
$P_s^{ru}[k], P_s^{rd}[k]$	Reg-up and Reg-down capacity from storage (MW)

Point Forecasts:

$\hat{P}_w(k)$	Forecast output of wind farm
$\hat{\lambda}[k]$	Energy market price for electricity (DKK/MWh)
$\hat{\lambda}^{ru}[k]$	Regulation-up price (DKK/MW)
$\hat{\lambda}^{rd}[k]$	Regulation-down price (DKK/MW)

Functions:

$P_s[k]$	Net output power of storage
$E_s[k]$	Energy level of storage

Constants:

C_w	Marginal cost of wind (DKK/MW)
C_w^r	Cost for providing regulation (DKK/MW)
C_s	Charging/discharging (degradation) cost of storage (DKK/MW)
P_s^{max}	Rated power of storage device (MW)
E_s^{max}	Upper limit on energy level of storage device (MWh)
E_s^{min}	Lower limit on energy level of storage device (MWh)
η	Round-trip efficiency of the storage device (%)
η_d	Discharging efficiency of the storage device (%)
η_c	Charging efficiency of the storage device (%)
N	Number of time periods (for 1 day $N = 24$)

The robust optimization problem for joint energy and frequency regulation market

bidding for the combination of a wind farm and energy storage device is expressed as follows.

$$\begin{aligned}
& \min_{\vec{P}_w[k], \vec{P}_w^{ru}[k], \vec{P}_w^{rd}[k], \vec{P}_s^{ru}[k], \vec{P}_s^{rd}[k]} \max_{\hat{\lambda} \in \mathcal{U}, \hat{P}_w \in \mathcal{V}} \sum_{k=1}^{24} [-\hat{\lambda}[k] \hat{P}_w[k] - \hat{\lambda}^{ru}[k] (P_w^{ru}[k] + P_s^{ru}[k]) \\
& \quad - \hat{\lambda}^{rd}[k] (P_w^{rd}[k] + P_s^{rd}[k] + C_w P_w[k]) \\
& \quad + C_s (P_s^d[k] + P_s^c[k]) + C_w^r (P_w^{ru}[k] + P_w^{rd}[k]) \quad (3.23)
\end{aligned}$$

s.t.

$$0 \leq P_w^{ru}[k] \leq \hat{P}_w[k] - P_w[k] \quad (3.24)$$

$$0 \leq P_w^{rd}[k] \leq P_w[k-1] \quad (3.25)$$

$$0 \leq P_s^{ru}[k] \leq P_s^{max} - P_s[k-1] - (\hat{P}_w[k] - P_w[k]) \quad (3.26)$$

$$0 \leq P_s^{rd}[k] \leq P_s[k-1] \quad (3.27)$$

$$E_s[k] = E_s[k-1] - \frac{1}{\eta_d} P_s^d[k] + \eta_c P_s^c[k] \quad (3.28)$$

$$E_s^{min} \leq E_s[k] \leq E_s^{max} \quad (3.29)$$

The objective function (3.23) consists of (i) revenue from the bids in both energy and regulation markets, and (ii) various associated costs including the marginal cost of wind, degradation costs associated with charging and discharging, and cost of providing regulation. By minimizing the negative of the total profit, we are effectively maximizing the total profit. The upper limit for regulation up capacity from the wind generator is the head room that has been created between the maximum power output potential (based on wind speed forecast) and the actual power output to the grid (based on the extent of curtailment) (3.24). The upper limit on regulation down

capacity of wind generator is the level of power output to the grid in the previous time step (3.25). It is assumed that the wind generator can ramp down to zero power output to grid. The amount of regulation up capacity that the storage device can provide depends on its power output level in the previous time period. Here the storage device is used so that the combination of the wind farm and storage can provide firm regulation up capacity to the grid. Given the inherent uncertainty with the wind forecast, it is assumed that the storage device acts as backup (3.26). The maximum amount of regulation down capacity available from the storage device depends its power output in the previous time period (3.27). The amount of energy in the storage device in any time period, $E_s(k)(MWh)$ depends on the charge/discharge history of the storage device, i.e. the storage dynamics (3.28). This equation also includes the energy losses during charging/discharging. The amount of energy that can be stored in the energy storage device has certain upper and lower bounds (3.29). The net power output of the storage is the difference between its discharging and charging power, i.e., $P_s(k) = P_s^d(k) - P_s^c(k)$.

Future work on this topic will focus on case studies for the robust optimization based joint bidding in energy and frequency regulation markets. Future work will also include investigating the impact of choice of uncertainty sets for price and wind power on the optimization solution.

4. ROBUST OPTIMIZATION BASED ECONOMIC DISPATCH*

4.1 Introduction

The increasing penetration of renewable resources such as wind and solar poses a challenge to the goal of the ISOs to manage the power system with a reliable and cost effective approach. Due to the limited control over the output of renewable resources as well as associated forecast errors the ISOs will have to deal with an increasing amount of uncertainty and variability in the power system as the penetration of renewables increases [31].

Fig. 4.1 illustrates the issue of uncertainty in the forecast of renewables. It shows the actual and day-ahead forecast wind power production profile for a day for the California ISO (CAISO) system. The forecast error for some hours can be high. On the day-ahead horizon load forecast error usually has $MAE = 1-2\%$, whereas for a region wind power forecast error can have $MAE=15\%$ or higher [69]. Even for the hour-ahead regional wind power forecast the MAE can be as high as 11%.

The other aspect of renewables is the variability in their output profiles. Fig. 4.2 shows the actual wind power output in the CAISO system for 5 consecutive days. From this figure we can see that the wind power can vary greatly during a day. Also unlike load which usually has a consistent diurnal pattern we see that the profile of wind power can vary from day to day.

In many electrical grids wind is not dispatched but considered as a negative load in the system. Thus, system operators are faced with the challenge of dispatching the generators in order to follow the system net load. The system net load is defined

*This section is in part a reprint of the material in the following paper: Reprinted with permission from A. A. Thatte, X. A. Sun, and L. Xie, "Robust Optimization Based Economic Dispatch for Managing System Ramp Requirement," in *Proc. 47th Hawaii Intl. Conf. on System Sciences*, Waikoloa, HI, Jan. 6-9, 2014, pp. 2344-2352. Copyright 2014, IEEE.

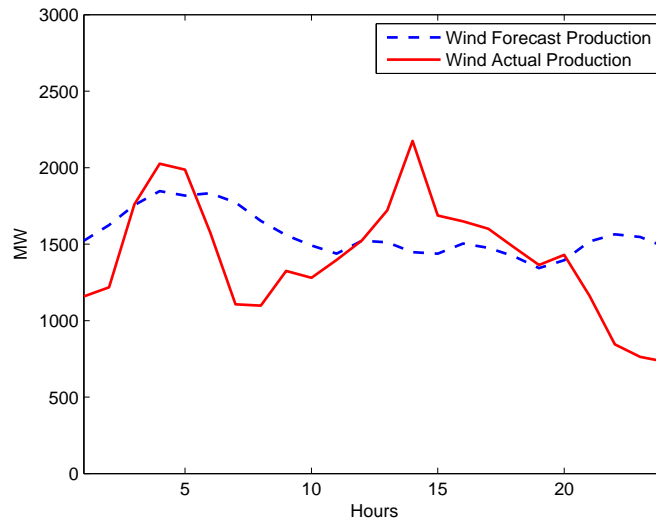

Figure 4.1: Wind actual and forecast production in CAISO for a day

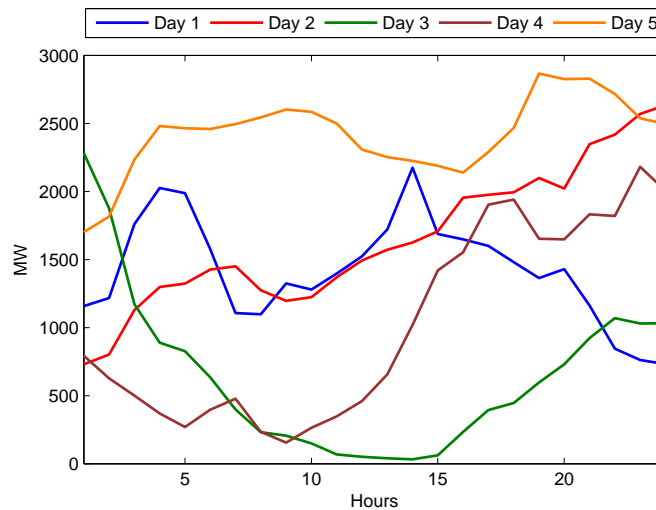

Figure 4.2: Wind production in CAISO for different days

as follows.

$$\begin{aligned}
 \text{Net Load} = & \text{Total Load} - \text{Renewable Generation} \\
 & + \text{Scheduled Interchanges (i.e., Exports} - \text{Imports)} \quad (4.1)
 \end{aligned}$$

As the penetration of wind generation in power systems increases the uncertainty in net load will increase significantly. Due to this uncertainty the conventional economic dispatch model, which dispatches the system for one interval at a time, is more inefficient in terms of total generation cost. Further, due to the increased variability of the net load the system as a whole needs greater rampable capacity in order to avoid shortage events. Thus many ISOs are investigating modifications to the conventional economic dispatch optimization model in order to improve the dispatch solution, and make it more cost-effective and reliable. The two main modified models that are being considered by system operators in the US are (i) ramp product, and (ii) look-ahead economic dispatch.

In this dissertation we propose a robust optimization based economic dispatch model for ensuring adequate system ramp capability. The proposed model is critically assessed with the ramp product model as well as the look-ahead dispatch model, which are currently under consideration by system operators. We conduct a theoretical assessment based on a proposed lack-of-ramp probability (LORP) index and a numerical assessment using Monte Carlo simulations. It is shown that compared with the recently proposed industry models, the proposed robust formulation of ramp requirement yields more smoothed generation cost variation and is capable of ensuring lower lack of ramp probability.

The main contributions of this section are as follows:

1. presents a robust optimization based economic dispatch model for ensuring a reliable dispatch solution for the power system.
2. proposes a novel metric for dispatch flexibility based on a probabilistic risk measure.
3. illustrates the proposed robust model on a small test system for the real time

economic dispatch.

4. compares the robust model to the current conventional economic dispatch model as well as the industry proposed ramp product and look-ahead dispatch models, in terms of dispatch costs, proposed flexibility metric and their impact on Locational Marginal Prices (LMPs).
5. presents the formulation for the implementation of robust dispatch in a multi-zonal system with transmission line flow constraints considered.
6. illustrates the proposed robust model on a multi-zonal IEEE 24 bus Reliability Test System (RTS) for real time economic dispatch using realistic data.

4.2 System Operator Initiatives to Improve Dispatch

4.2.1 Ramp Capability Model

One significant challenge for system operators is the temporary price spikes experienced in the real time electricity market due to shortages attributed to a lack of system ramp capability [41]. The main causes of these shortages include variability of load, scheduled interchanges and non-controllable generation resources (primarily wind) as well as uncertainty associated with short term forecasts. Due to the physical limitations on ramp rates generators are unable to respond effectively to these price spikes. The current practices to deal with ramp shortages include increasing reserve margins, starting fast-start units (such as gas turbines) and out of market dispatch methods that involve operator action. However, these approaches are usually high cost or create some market distortion. It is important for ISOs to have additional flexibility for dispatchable generation resources through the market clearing process. The Security Constrained Economic Dispatch (SCED) decision needs to be robust

to the uncertainties so that the critical system power balance requirement is not violated.

An approach called the *ramp capability model* or *ramp product* is currently being investigated by Midcontinent ISO (MISO) {formerly called Midwest Independent Transmission System Operator} which involves a modification to the conventional Security Constrained Economic Dispatch (SCED) formulation to include additional ramp capability constraints [75]. The proposed economic dispatch with ramp product aims to cover forecast variability in net load as well as uncertainty, which is calculated based on a statistical analysis of historical data available to the system operator. CAISO is also investigating a *flexible ramping product* in order to create additional flexibility in the dispatch so that the occurrences of ramp shortage and temporary price spikes are greatly reduced [43].

The proposed ramp product comprises of the following additional constraints which are to be added to the current SCED formulation [76, 42]:

1. Ten minute Ramp Capability for each dispatchable resource
2. System (or Zonal) Ramp Capability requirement

As shown in Fig. 4.3 the dispatch solution must match both variability and uncertainty in net load over 2 dispatch intervals i.e., 10 minutes. Further, it must account for the uncertainty around point forecast (based on confidence interval) = $\pm u$.

The system ramp capability requirement would allow dispatchable generators to respond to any forecast variations in net load as well as uncertainty. The uncertainty in net load can be estimated based on a statistical analysis of its components and then combining them. The statistical characterization of individual components of net load may be obtained from historical data [75]. We present a simplified version

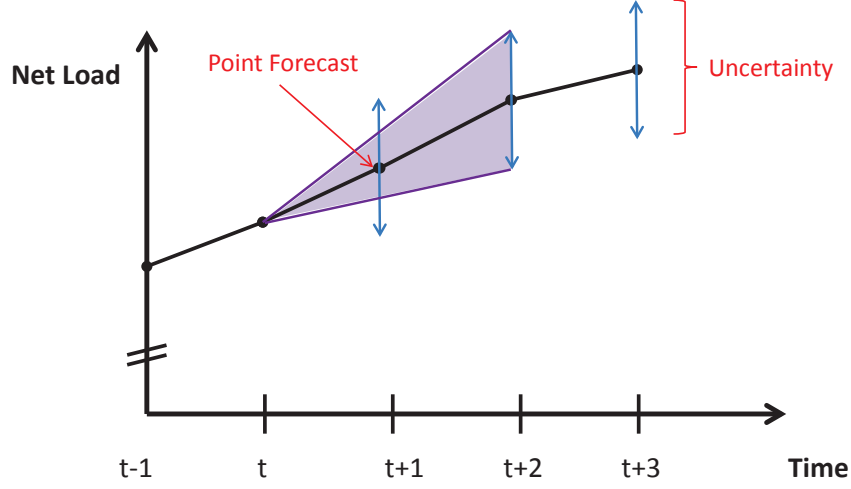

Figure 4.3: Illustration of system ramp capability requirement

of the formulation of the dispatch with ramp product for the real time market. The actual formulation will include regulation reserve, contingency reserves and network constraints, which are omitted here for simplifying the exposition. The dispatch scheme is posed as an optimization problem with the aim of obtaining the least cost dispatch solution to maintain the system power balance as well as meet generator power output and ramp constraints. The notation used is given in Table 4.1.

$$\min_{P_i^g[t]} \sum_{i=1}^{N_g} C_i^g(P_i^g[t]) \quad (4.2)$$

$$\sum_{i=1}^{N_g} P_i^g[t] = \hat{P}^l[t] \quad (4.3)$$

$$P_i^g[t] + RCU_i[t] \leq P_i^{max}, \forall i, t \quad (4.4)$$

$$P_i^g[t] + RCD_i[t] \geq P_i^{min}, \forall i, t \quad (4.5)$$

$$P_i^g[t] - P_i^g[t-1] \leq R_i, \forall i \quad (4.6)$$

Table 4.1: Notation for economic dispatch models

t	Time index of real time dispatch (5 min. intervals)
$C_i^g()$	Cost function of generator i
$P_i^g[t]$	Dispatched output of generator i at time t
N_g	Total number of generators in system
P_i^{max}	Maximum output of generator i
P_i^{min}	Minimum output of generator i
$\hat{P}^l[t]$	System net load forecast at time t
$\tilde{P}^l[t]$	System net load uncertain variable
RCU_i	Cleared ramp up capability of resource i
RCD_i	Cleared ramp down capability of resource i
RCU_s	System wide ramp up requirement
RCD_s	System wide ramp down requirement
R_i	One interval (5 min.) ramp rate of resource i
$F[t]$	Vector of line flows at the time t
F^{max}	Vector of line flow limits
U	Uncertainty set for net load

$$P_i^g[t-1] - P_i^g[t] \leq R_i, \forall i \quad (4.7)$$

$$-F^{max} \leq F[t] \leq F^{max}, \forall t \quad (4.8)$$

$$RCU_i[t] \leq 2R_i, \forall i \quad (4.9)$$

$$RCD_i[t] \leq 2R_i, \forall i \quad (4.10)$$

$$\sum_{i=1}^{N_g} RCU_i[t] \geq RCU_s[t] \quad (4.11)$$

$$\sum_{i=1}^{N_g} RCD_i[t] \geq RCD_s[t] \quad (4.12)$$

where

$$RCU_s[t] = \hat{P}^l[t+2] - \hat{P}^l[t] + u \quad (4.13)$$

$$RCD_s[t] = -(\hat{P}^l[t+2] - \hat{P}^l[t]) + u \quad (4.14)$$

and u is the estimated system net load uncertainty

(4.2)-(4.8) comprise the conventional SCED formulation, whereas, (4.9)-(4.12) are the modifications for the ramp capability. The objective of SCED (4.2) is the sum of dispatch costs of all generators which are committed by the unit commitment (UC). (4.3) is the power balance constraint where it is assumed that the current time interval net load forecast $\hat{P}^l[t]$ is accurate. Any small deviations are handled in the frequency regulation time frame. Violation of this constraint carries with it a very high cost and so ISOs would like to avoid such events.

The implementation of the ramp product would be as follows. The generators will submit their bids for the current time interval. The system operator will run the optimization with the ramp capability constraints and thereby obtain the dispatch allocation for each generator. The LMPs will be based on the Lagrangian multipliers associated with the system power balance constraint (4.3). Thus the operation of the dispatch with ramp product model will be similar to the conventional single interval economic dispatch which is presently used in the ISO electricity markets.

4.2.2 Look-Ahead Economic Dispatch

Many ISOs are also investigating look-ahead economic dispatch models in order to dispatch generators using a more cost-effective and reliable approach [77]. The proposed look-ahead economic dispatch uses the short-term forecast of load and wind to calculate the optimal dispatch solution over multiple time intervals. Thus compared to the conventional economic dispatch, look-ahead dispatch is more cost-effective and more reliable. The functionality provided by look-ahead dispatch is distinct from that of the ramp capability model.

The formulation of the look-ahead economic dispatch is given as follows [78].

$$\min_{P_i^g[t]} \sum_{t=1}^T \sum_{i=1}^{N_g} C_i^g(P_i^g[t]) \quad (4.15)$$

s.t.

$$\sum_{i=1}^{N_g} P_i^g[t] = \sum_{j=1}^{N_l} \hat{P}_j^l[t], \quad \forall t = 1, \dots, T \quad (4.16)$$

$$|P_i^g[t] - P_i^g[t-1]| \leq R_i, \quad \forall i, \forall t = 1, \dots, T \quad (4.17)$$

$$P_i^{min} \leq P_i^g[t] \leq P_i^{max}, \quad \forall i, \forall t = 1, \dots, T \quad (4.18)$$

$$-F^{max} \leq F[t] \leq F^{max}, \quad \forall t = 1, \dots, T \quad (4.19)$$

Both ramp product and look-ahead economic dispatch can be used either individually or combined to better manage the dispatch of generators.

4.2.3 Comparison of Ramp Product

The key features of the ramp product can be compared to the look-ahead dispatch and the frequency regulation reserves. Table 4.2 compares the key features of the ramp product to the look-ahead dispatch model. Table 4.3 compares the ramp product to the frequency regulation reserve.

Table 4.2: Ramp product vs. look-ahead

Ramp Product	Look-Ahead
Similarities	
Deals with ramping	Deals with ramping
Reduces scarcity price instances	Reduces scarcity price instances
Differences	
Adjust ramp to deal with net load variability	Pre-ramps to reduce dispatch costs over multiple intervals
Based on uncertainty and expected change in net load	Based on deterministic forecast change in net load

Table 4.3: Ramp product vs. regulation

Ramp Product	Regulation
Similarities	
Deals with unexpected changes in load	Deals with unexpected changes in load
Differences	
Deals with net load variation in dispatch horizon (every 5 min)	Deals with net load variation in AGC horizon (seconds to minutes)
Applies to changes between economic dispatch intervals	Applies to changes within given interval
Dispatched by Economic Dispatch	Dispatched by AGC

4.2.4 Need for Robust Economic Dispatch

Even with the ramp capability modification or the look-ahead dispatch model there is a significant probability of shortage events due to lack of system ramp capability. The SCED decision needs to be robust to the uncertainties so that the critical system power balance requirement is not violated. Therefore, in this dissertation a robust optimization based economic dispatch model is proposed, which gives dispatch decisions that are robust to uncertainties in the system net load.

4.3 Robust Economic Dispatch Formulation

The aim of the SCED is to find the least cost generation dispatch in order to satisfy the system power balance constraint while at the same time meeting other constraints such as generator power output and ramping limits.

Some ISOs also procure regulation reserve and contingency reserves through SCED by means of co-optimization with energy. For simplicity regulation reserve and contingency reserves are omitted from this presentation. Regulation reserves are used in the frequency regulation time scale rather than the economic dispatch time scale. Contingency reserves are used in case of reportable disturbances and not for

handling normal power system operations.

The robust economic dispatch formulation is as follows.

The objective is to minimize total generation cost over current and next time interval.

$$\min_{P_i^g[t], P_i^g[t+1]} \sum_{i=1}^{N_g} C_i^g(P_i^g[t] + P_i^g[t+1]) \quad (4.20)$$

s.t.

$$\sum_{i=1}^{N_g} P_i^g[t+1] \geq \max_{\tilde{P}^l[t+1] \in U} \tilde{P}^l[t+1] \quad (4.21)$$

This constraint is included so that the dispatch solution in the next time interval will be feasible under even the worst case realization of net load. The net load in the next time interval is assumed to be an uncertain variable which belongs to a given deterministic uncertainty set U . The uncertainty in net load arises from its components viz., system load, renewable generation (such as wind, solar etc.) and scheduled interchanges.

$$\sum_{i=1}^{N_g} P_i^g[t] = \hat{P}^l[t] \quad (4.22)$$

The current interval net load forecast is assumed to be accurate, and if there are any deviations they can be handled by the frequency regulation control.

$$P_i^g[t] \leq P_i^{max} \forall i, t \quad (4.23)$$

$$P_i^g[t] \geq P_i^{min} \forall i, t \quad (4.24)$$

The scheduled output power for each generator must remain within its active power output limits.

$$P_i^g[t] - P_i^g[t-1] \leq R_i \forall i \quad (4.25)$$

$$P_i^g[t-1] - P_i^g[t] \leq R_i \forall i \quad (4.26)$$

$$P_i^g[t + 1] - P_i^g[t] \leq R_i \forall i \quad (4.27)$$

$$P_i^g[t] - P_i^g[t + 1] \leq R_i \forall i \quad (4.28)$$

The change in power output is limited by the ramping ability of each generator in the given time period.

$$-F^{max} \leq F[t] \leq F^{max} \forall t \quad (4.29)$$

The transmission line capacity constraints must be satisfied for all the branches in the transmission network.

$$U = \tilde{P}^l[t + 1] \in [\hat{P}^l[t + 1] - \Delta P^l[t + 1], \hat{P}^l[t + 1] + \Delta P^l[t + 1]] \quad (4.30)$$

where $\Delta P^l[t + 1]$ is the maximum deviation of net load from the point forecast value $\hat{P}^l[t + 1]$. The deterministic uncertainty set defines the range of the uncertain future net load variable.

The real time market bidding and clearing for the robust economic dispatch model will work as follows. At each time step t the generating resources will submit their bids for the current and the next time interval, namely t and $t + 1$, similar to a look-ahead economic dispatch model. The system operator will perform a uniform price auction and the cost will be minimized while at the same time ensuring that all the constraints are satisfied. At each time step the current dispatch solution will be binding, whereas the future interval dispatch result will be advisory and can be modified in the subsequent dispatch.

In the general case the robust optimization formulation presented above can be extended to include more than one future time steps. That is the uncertain net load variables $\tilde{P}^l[t + 1], \tilde{P}^l[t + 2], \tilde{P}^l[t + 3] \dots$ can be included in the formulation, where each of these variables can be assumed to belong to a deterministic uncertainty

set U_1, U_2, U_3, \dots each of which can be defined similar to (4.30). Accordingly, the objective function can be modified and additional constraints added to account for these additional variables.

4.3.1 Ramp Capability Reliability Index

In the probabilistic determination of contingency reserves the loss of load probability (LOLP) is used as a reliability index [79]. It is the probability that the generation resources combined with reserves will not be able to meet the demand. Analogous to this concept, in this dissertation we propose a risk index for the system ramp capability being insufficient to meet the change in net load due to a lack of available ramp capacity from dispatched generators. This is called the *lack of ramp probability* (LORP) and is defined as follows:

$$LORP^{up}[t] = Pr\left[\sum_{i=1}^{Ng} \{P_i^g[t] + \min(2R_i, P_i^{max} - P_i^g[t])\} < \tilde{P}^l[t+2]\right] \quad (4.31)$$

Fig. 4.4 illustrates the concept, where the shaded area under the curve represents the probability that the system power balance will be violated in the future (second interval ahead from current) due to insufficient available system ramp capability.

It is assumed that the 10 minute ahead net load $\tilde{P}^l[t+2]$ is a normally distributed random variable with known mean (equal to the point forecast of net load) and known standard deviation (estimated from historical data). Similar to (4.31) for the ramp up case, the lack of ramp probability for the ramp down case can be defined as follows.

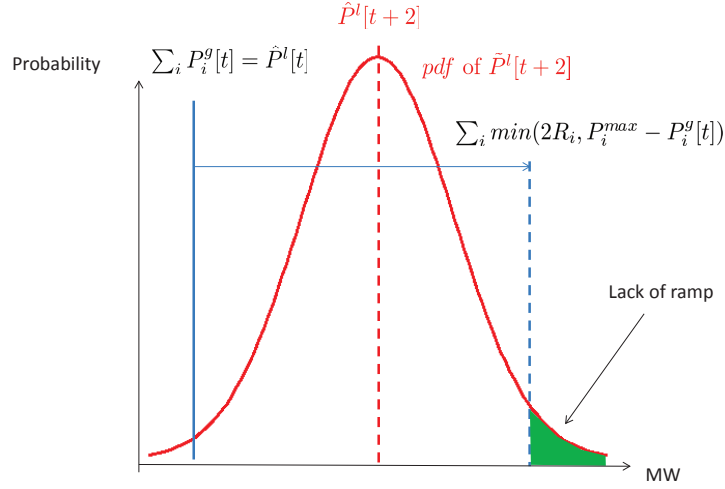

Figure 4.4: Lack of ramp probability

$$LORP^{down}[t] = Pr\left[\sum_{i=1}^{Ng} \{P_i^g(t) - \min(2R_i, P_i^g(t) - P_i^{min})\} > \tilde{P}^l(t+2)\right] \quad (4.32)$$

Next we investigate the link between the ramp capability requirement and the lack of ramp index in the ramp up case. The link for the ramp down case can be derived similarly.

Based on (4.4) and (4.9) the cleared ramp capability of each resource i obeys the following constraints.

$$RCU_i[t] \leq \min(2R_i, P_i^{max} - P_i^g[t]) \forall i \quad (4.33)$$

The probability that the cleared ramp capability from all resources is inadequate to meet system requirement is given by

$$\begin{aligned}
Pr \left[\sum_i RCU_i[t] < RCU_s[t] \right] &= Pr \left[\sum_i RCU_i[t] < \hat{P}^l[t+2] - \hat{P}^l[t] + u \right] \\
&= Pr \left[\hat{P}^l[t] + \sum_i RCU_i[t] < \hat{P}^l[t+2] + u \right] \quad (4.34)
\end{aligned}$$

We now make the following assumptions.

1. The current interval net load forecast is accurate and any deviations are handled in the frequency regulation time scale, thus $\sum_i P_i^g[t] = \hat{P}^l[t]$.
2. The cleared ramp up capability from each resource is at its maximum, thus $RCU_i[t] = \min(2R_i, P_i^{max} - P_i^g[t])$
3. We can write $\hat{P}^l[t+2] + u = \tilde{P}^l[t+2]$ which is an uncertain variable.

Thus from (4.34) we have

$$\begin{aligned}
&Pr \left[\sum_i RCU_i[t] < RCU_s[t] \right] \\
&= Pr \left[\sum_i P_i^g[t] + \sum_i \min(2R_i, P_i^{max} - P_i^g[t]) < \tilde{P}^l[t+2] \right] \\
&= LORP^{up} \quad (4.35)
\end{aligned}$$

In the more general case, from the derivation (4.33)-(4.35) without Assumption 2 we know that

$$Pr \left[\sum_i RCU_i[t] < RCU_s[t] \right] \geq LORP^{up} \quad (4.36)$$

because $\sum_i RCU_i[t] < RCU_s[t]$ implies that $\sum_i (P_i^g[t] + \min(2R_i, P_i^{max} - P_i^g[t])) < \tilde{P}^l[t+2]$.

Thus LORP gives a bound on the probability that a ramp shortage event will occur. Also if $Pr [\sum_i RCU_i[t] < RCU_s[t]] \leq \epsilon$, then we can guarantee $LORP^{up} \leq \epsilon$ but not the other way around.

LORP can be used to calculate the probability of ramp shortage event occurring under the current SCED formulation. LORP can also be used to obtain the reliability of the dispatch solution in case we have an empirical probability distribution of net load.

4.3.2 Numerical

We compare the current single interval economic dispatch to the economic dispatch with ramp product and also to the robust economic dispatch by using a numerical in a simple test system.

Table 4.4 shows the generator characteristics for 3 conventional (dispatchable) generators.

Table 4.4: Generator characteristics

Generator	G1	G2	G3
Minimum Output (MW)	10	10	10
Maximum Output (MW)	130	130	100
Ramp Rate (MW/min)	4	1	1
Offer Price (\$/MWh)	30	31	36
Initial Output (MW)	100	10	10

Table 4.5 shows the net load forecasts, which are used for calculating the ramp capability requirements in each interval Tn .

Table 4.6 shows the required ramp capability up and ramp capability down requirements which are based on the change in forecast net load ΔNL and the uncer-

Table 4.5: Net load forecasts

Forecast	T1	T2	T3	T4	T5	T6
@ T1	136	149	164			
@ T2		151	163	173		
@ T3			160	174	177	
@ T4				171	175	179

tainty. Assuming a normal distribution of net load, taking the maximum uncertainty as $\pm 3\sigma$ around the mean value should cover 99.73% of uncertainty cases as per the theory of the *3 - sigma method*.

Table 4.6: Ramp capability requirements

Interval	T1	T2	T3	T4
ΔNL (MW)	28	22	17	8
3σ uncertainty (MW)	8	8	8	8
RCU_s (MW)	36	30	25	16
RCD_s (MW)	20	14	9	0

Since the system net load is generally increasing in this example we will focus on the ramp up capability. The total system ramp capability up requirement RCU_s in each time interval is the sum of the change in forecast net load ΔNL and the uncertainty.

In what follows, we first show a detailed comparison of the three models - conventional, ramp capability and robust, in terms of generators output, total dispatch cost, LMPs and $LORP^{up}$.

From Table 4.7 we can see that with conventional economic dispatch, in interval T4 the total generation is insufficient to meet the net load. We also note the high $LORP^{up}$ value in interval T2 which means that there is a high probability of such

Table 4.7: Conventional economic dispatch results

Interval	T1	T2	T3	T4
Net Load (MW)	136	151	160	171
G1 (MW)	116	130	130	130
G2 (MW)	10	11	16	21
G3 (MW)	10	10	14	19
Total Output (MW)	136	151	160	170
LMP (\$/MWh)	30	31	36	3500
$LORP^{up}$	0.0122	0.7735	0.1304	≈ 0

shortage occurring in interval T4. The lack of system ramp capability results in a violation of the power balance constraint. To avoid this constraint violation the system operator will have to take some action such as sending a turn-on signal to a fast start generating unit to bridge the power gap. This shortage results in a temporary price spike in the real time market. In MISO the price associated with system power balance constraint violation is assumed to be equal to the Value of Lost Load (VOLL), which is \$3500/*MWh* [80].

Table 4.8: Results of dispatch with ramp product

Interval	T1	T2	T3	T4
Net Load (MW)	136	151	160	171
G1 (MW)	114	120	125	130
G2 (MW)	12	17	22	27
G3 (MW)	10	14	13	14
Total Output (MW)	136	151	160	171
LMP (\$/MWh)	31	36	36	36
$LORP^{up}$	0.0013	0.0013	0.0013	≈ 0

However, in the economic dispatch with ramp product, as seen in Table 4.8 the dispatch solution is adjusted to avoid the shortage event. The inclusion of ramp

capability constraints may lead to higher locational marginal prices (LMPs) in other non-shortage intervals. For instance we see from Table 4.8 (using $u = 3\sigma = 8MW$) that in the interval T1 due to the different dispatch the LMP has changed from $\$30/MWh$ to $\$31/MWh$.

We evaluate the lack of ramp probability index for the interval $T1$. As shown in Fig. 4.5 the total generation in interval T1 is 136 MW, and the total available two interval ramp capability is 36 MW. The net load is assumed to be a normally distributed random variable with the mean assumed to be equal to the point forecast value in interval T3, namely 164 MW and the standard deviation $\sigma = 8/3$ MW. Since the system can't ramp up to greater than 172 MW the shaded area under the pdf of the net load represents the lack of ramp probability. Thus for the interval T1 the $LORP^{up} = 0.0013$.

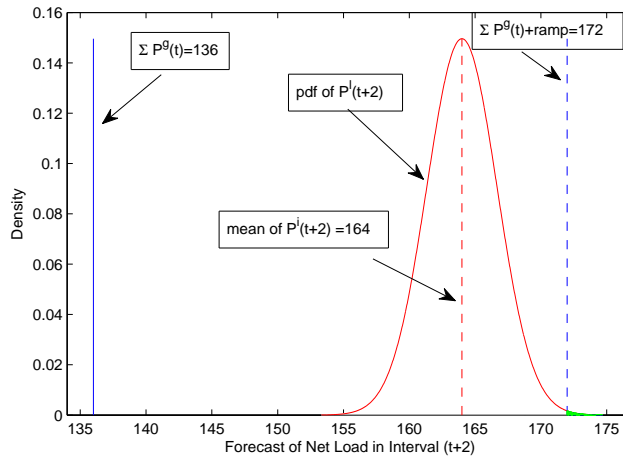

Figure 4.5: Lack of ramp probability for interval T1

Next we consider the robust economic dispatch model. In order to define the

uncertainty set we choose the maximum deviation $\Delta P^l = 4MW$ for each interval. Table 4.9 shows the dispatch results for the robust model. In the robust approach the shortage in interval T4 is avoided.

Table 4.9: Robust economic dispatch results

Interval	T1	T2	T3	T4
Net Load (MW)	136	151	160	171
G1 (MW)	116	124	123	130
G2 (MW)	10	15	20	25
G3 (MW)	10	12	17	16
Total Output (MW)	136	151	160	171
LMP (\$/MWh)	31	36	36	36
$LORP^{up}$	0.0122	0.0669	≈ 0	≈ 0

Table 4.10 shows the generation (offer) costs on a 5 minute interval basis for each economic dispatch approach. For the conventional economic dispatch the generation cost in interval T4 is high because the committed generators G1 to G3 are not able to satisfy the net load. Therefore, in this interval the system operator has to dispatch a fast start unit to ensure that the system power balance constraint is not violated. The cost associated with this generator is assumed to be the VOLL.

Table 4.10: Generation cost comparison

Interval	Conventional (\$)	Ramp Capability (\$)	Robust (\$)
T1	345.83	346	345.83
T2	383.42	385.92	384.75
T3	408.33	408.33	410.17
T4	727.92	436.75	437.58
Total	1865.5	1577	1578.33

As shown in Table 4.10 the total generation cost associated with the robust approach (Table 4.9), is higher than that of the dispatch with ramp product approach (Table 4.8), due to the conservative nature of the robust approach. However, this approach avoids the shortage situation that we encounter in the conventional dispatch approach (Table 4.7).

Table 4.11: Generation cost and reliability comparison of dispatch methods

Dispatch with ramp product			Robust dispatch		
u	\sum GenCost	$\sum LORP^{up}$	ΔP^l	\sum GenCost	$\sum LORP^{up}$
8	1577	0.0039	8	1581	0.0026
4	1575.33	0.1460	4	1578.33	0.0792
2	1862.5	0.3694	2	1576.33	0.2403
1	1863.25	0.4966	1	1576.33	0.2403

In Table 4.11 the total generation cost for the 4 intervals and the total $LORP^{up}$ is shown for different levels of uncertainty in net load, for both the dispatch with ramp product approach and the robust dispatch approach. From Table 4.11 we see that the robust dispatch solutions have higher reliability (i.e., lower aggregate $LORP^{up}$) for all four cases and slightly higher generation costs for $u = 8MW$ and $u = 4MW$. In the dispatch with ramp product cases with uncertainty $u = 2MW$ and $u = 1MW$ we find that a shortage event occurs in interval T4, which requires the system operator to dispatch a fast-start unit and therefore incurs high cost.

For a more direct comparison between the two methods we consider the first two rows of Table 4.11. We see that with the robust model the generation costs are only slightly higher, but we get significant improvement in the reliability level as measured by $LORP^{up}$. The system operator can adjust the choice of ΔP^l keeping in mind this trade-off.

Next we use Monte Carlo simulation to assess the performance of the robust approach relative to the conventional economic dispatch and the economic dispatch with ramp product. To generate the net load scenarios each net load forecast in Table 4.5 is assumed to be a random variable. In each case the net load forecast is chosen at random from a truncated Gaussian distribution with the mean values indicated in Table 4.5, the standard deviation $\sigma = 8/3$, and maximum deviation $\pm 8MW$. Thus 1000 scenarios are generated for a 20 minute real time dispatch time frame, and thus with 4 consecutive dispatch intervals in each scenario we simulate a total of 4000 intervals.

In the conventional economic dispatch, shortages occur in 983 intervals, in the economic dispatch with ramp product (taking $u = 8MW$) they occur in 540 intervals and in the robust economic dispatch (taking $\Delta P^l = 4MW$) shortages occur in 42 intervals. Further we calculate the mean and the standard deviation of the total generation cost of 4 intervals for the scenarios. In case of the dispatch with ramp product the mean generation cost = \$2,208.33 and standard deviation = \$717.25, whereas for the robust dispatch approach the mean generation cost = \$1600.92 and standard deviation = \$238.75. The mean lack of ramp probability for a single interval across all scenarios (i.e., mean $LORP^{up}$) for dispatch with ramp product is 0.1890, whereas for the robust dispatch mean $LORP^{up}$ is 0.0512. Table 4.12 provides a summary of the results of the Monte Carlo simulations for the different economic dispatch methods.

Thus with robust dispatch on average the total generation cost is expected to be lower since there is lower probability of a shortage event occurring. Additionally, the variance in the robust dispatch approach is lower than that in the dispatch with ramp product approach. Finally, the robust dispatch solutions yield a lower mean lack of ramp probability compared to the dispatch with ramp product solutions, indicating

Table 4.12: Summary of monte carlo results

Dispatch Method	Conventional (\$)	Ramp Capability (\$)	Robust (\$)
Ramp Shortage Events	983	540	42
Mean Scenario Costs (\$)	2398	2208	1601
Standard dev. (\$)	733	717	239
Mean $LORP^{up}$	0.2415	0.1890	0.0512

that the robust model is more reliable than the dispatch with ramp product.

4.4 Zonal Robust Economic Dispatch with Tie-Line Limits

In this subsection we present a robust optimization based economic dispatch model which includes tie-line constraints for implementation in multi-zonal systems. Fig. 4.6 shows a comparison of this model to the look-ahead dispatch model presented earlier in this section as well as the conventional dispatch model. This formulation can be extended to consider multiple future time intervals in the economic dispatch horizon. The net load for each future time step can be considered as uncertain. For defining the robust dispatch problem we can consider the uncertain net loads in the future time intervals as belonging to the uncertainty sets $\mathcal{U}_1, \mathcal{U}_2, \dots, \mathcal{U}_n$.

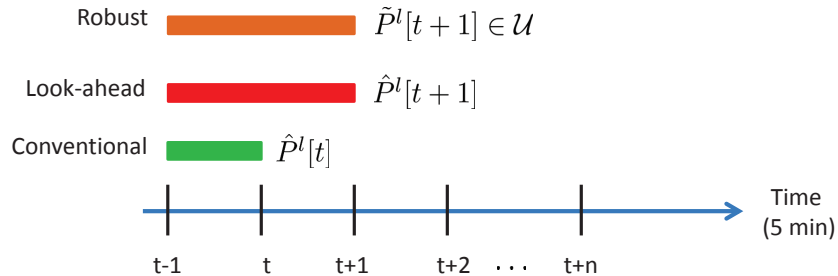

Figure 4.6: Comparison of economic dispatch models

Table 4.13: Notation for multi-zonal robust dispatch

Indices:

n	Index of all buses in the network.
z	Index of all zones in the network.
i	Index of all dispatchable generators.
j	Index of all loads.
m	Index of all transmission lines.
t	Index of real time dispatch (5 min. intervals).

Sets:

N	Set of buses.
Z	Set of zones.
$I \subset N$	Set of generators.
$J \subset N$	Set of loads.
I^z	Set of generators in zone $z \in Z$.
J^z	Set of loads in zone $z \in Z$.
M	Set of transmission lines.

Deterministic Forecast:

$\hat{P}_j^l[t]$	Net load forecast of bus j at time t .
$\hat{P}_z^l[t]$	Net load forecast of zone z at time t .

Random Variables:

$\tilde{P}_j^l[t]$	Net load at bus j .
$\tilde{P}_z^l[t]$	Net load in zone z .
u_s	Uncertainty of system-wide net load.
u_z	Uncertainty of net load in zone z .

Decision Variables:

$P_i^g[t]$	Dispatched output of generator i at time t .
------------	--------------------------------------------------

Functions:

$C_i^g()$	Cost function of generator i .
-----------	----------------------------------

Parameters and Constants:

T	Number of intervals in dispatch horizon.
P_i^{max}	Maximum output of generator i .
P_i^{min}	Minimum output of generator i .
R_i	One interval (5 min.) ramp rate of generator i .
F^{max}	Vector of flow limits for transmission lines.
F_z^{max}	Vector of flow limits for inter-zonal tie-lines.
U_s	Uncertainty set for system-wide net load.
U_z	Uncertainty sets for net load in zone z .
ΔP_z^l	Maximum deviation of net load in zone z from point forecast value.
H	Shift factor matrix ($m \times n$).
H^z	Reduced shift factor matrix considering only inter-zonal tie-lines.

The conventional economic dispatch model is used to find a least-cost dispatch solution that satisfies the system power balance constraint as well as other constraints such as the generator resource limits and inter-temporal ramping limits. This is a single interval deterministic optimization problem which does not consider either uncertainty in load or the forecast for future time intervals.

The robust dispatch formulation presented earlier in this section considers one future time interval in the economic dispatch horizon. The net load in the future time interval is assumed to be uncertain and to belong to a predefined deterministic uncertainty set. Also we consider the inter-zonal transmission line flow limits in the dispatch formulation. Based on this idea we can extend the robust economic dispatch formulation to span multiple future time intervals each with an uncertain net load belonging to an uncertainty set. Thus, we can formulate a multi-interval robust dispatch model.

The robust multi-zonal economic dispatch model with transmission line constraints is formulated as follows, and the notation is given in Table 4.13:

$$\min_{P_i^g[t]} \sum_{t=1}^T \sum_{i \in I} C_i^g(P_i^g[t]) \quad (4.37)$$

s.t.

$$\sum_{i \in I} P_i^g[t] = \sum_{j \in J} \hat{P}_j^l[t], \quad t = 1 \quad (4.38)$$

$$\sum_{i \in I} P_i^g[t] \geq \sum_{j \in J} \tilde{P}_j^l[t], \quad \forall t = 2, \dots, T \quad (4.39)$$

$$P_i^{min} \leq P_i^g[t] \leq P_i^{max} \quad \forall i, t \quad (4.40)$$

$$-R_i \leq P_i^g[t] - P_i^g[t-1] \leq R_i \quad \forall i, t \quad (4.41)$$

$$-F_{[1:m]}^{max} \leq H(P_{[1:n]}^g[t] - \hat{P}_{[1:n]}^l[t]) \leq F_{[1:m]}^{max}, t = 1 \quad (4.42)$$

$$-F_z^{max} \leq H^z\left(\sum_{i \in I^z} P_i^g[t] - (\hat{P}_z^l[t] + u_z[t])\right) \leq F_z^{max}, \forall t = 2, \dots, T, u_z \in U_z, \forall z \quad (4.43)$$

The objective is to minimize total generation cost over all the time intervals (4.37). (4.38) gives the system power balance constraint for the current time interval. The constraints (4.39) ensure that the dispatch solutions for the future time intervals are feasible even under the worst cases of net load uncertainty, as defined by their respective uncertainty sets. The dispatched output power for each generator must remain within its active power output limits (4.40). Constraints (4.41) specify the inter-temporal ramping limits of each generator. The transmission line flow limits must be satisfied for all the lines in the transmission network, represented by constraints (4.42). For ensuring deliverability of ramp capability we consider only the inter-zonal tie-line limits for the future time intervals (4.43). We do not consider the line limits within the zones for the future time intervals. The entire load and generation of the zone is represented as a single net injection. For buses which do not have generators $P_n^g = 0$, and similarly for buses which do not have loads $P_n^l = 0$.

The uncertain system net load variable can be written as a combination of the deterministic point forecast and an uncertain variable u_s . Thus we have $\sum_{j \in J} \tilde{P}_j^l[t] = \sum_{j \in J} \hat{P}_j^l[t] + u_s[t]$, where $u_s[t] \in U_s[t]$. We define uncertainty sets for each zone based on historical data for net load uncertainty. For instance we can use the previous day's zonal net loads to find the information about the uncertainty.

$$U_z[t] = [\hat{P}_z^l[t] - \Delta P_z^l[t], \hat{P}_z^l[t] + \Delta P_z^l[t]], \forall t = 2, \dots, T, \forall z \quad (4.44)$$

We can assume that $\Delta P_z^l[t] = \alpha_z \sigma_z$, where α_z is a constant of proportionality and σ_z is the standard deviation for the zonal net load, obtained from historical data.

α_z can be selected by the system operator. It can be higher or lower based on the confidence in the net load forecast. For instance we could select $\alpha_z = 3$ and hence have an uncertainty set covering $\pm 3\sigma$ deviations from the mean.

Thus, the deterministic uncertainty sets (4.44) define the range of the uncertainty in the net load for the future time intervals.

To ensure deliverability of ramp capability we consider only the inter-zonal tie-line flow limits in (4.43). The network can be reduced to find an equivalent network using bus aggregation method. Using the approach given in [81] the network can be reduced to one where each zone is reduced to a single bus with an aggregated net injection. The intra-zonal flow limits are ignored and the inter-zonal tie-lines are aggregated to a single equivalent tie-line in each case. Then the reduced shift factor matrix H^z is obtained for the reduced equivalent zonal system.

4.4.1 Nodal Robust Dispatch

We can also formulate a nodal version of the robust dispatch. The uncertainty sets would have to be defined at the bus level rather than at the zonal level. The nodal robust economic dispatch model with line constraints is as follows:

$$\min_{P_i^g[t]} \sum_{t=1}^T \sum_{i \in I} C_i^g(P_i^g[t]) \quad (4.45)$$

s.t.

$$\sum_{i \in I} P_i^g[t] = \sum_{j \in J} \hat{P}_j^l[t], \quad t = 1 \quad (4.46)$$

$$\sum_{i \in I} P_i^g[t] \geq \sum_{j \in J} (\hat{P}_j^l[t] + u_j[t]), \quad \forall t = 2, \dots, T, \quad \forall u_j[t] \in U_j[t] \quad (4.47)$$

$$P_i^{min} \leq P_i^g[t] \leq P_i^{max} \quad \forall i, t \quad (4.48)$$

$$-R_i \leq P_i^g[t] - P_i^g[t-1] \leq R_i \quad \forall i, t \quad (4.49)$$

$$-F^{max} \leq H(P_{[1:n]}^g[t] - \hat{P}_{[1:n]}^l[t]) \leq F^{max}, t = 1 \quad (4.50)$$

$$-F^{max} \leq H(P_{[1:n]}^g[t] - (\hat{P}_{[1:n]}^l[t] + u_{[1:n]}[t])) \leq F^{max}, \forall t = 2, \dots, T \quad (4.51)$$

$$U_j[t] = [\hat{P}_j^l[t] - \Delta P_j^l[t], \hat{P}_j^l[t] + \Delta P_j^l[t]], \forall t = 2, \dots, T, \forall j \quad (4.52)$$

Here again the deterministic uncertainty sets (4.52) can be defined using historical data on the uncertainty of net load at each bus in the system.

4.4.2 LMP Formulation in Robust Dispatch

Converting the set of equations (4.45)-(4.51) to the standard form we get the Lagrangian function of the robust economic dispatch as

$$\begin{aligned} \mathcal{L} = & \sum_{t=1}^T \sum_{i \in I} C_i^g(P_i^g[t]) - \lambda \left[\sum_{i \in I} P_i^g[t] - \sum_{j \in J} \hat{P}_j^l[t] \right] \\ & + \sum_{t=1}^T \delta[t] \left[- \sum_{i \in I} P_i^g[t+1] + \sum_{j \in J} (\hat{P}_j^l[t+1] + u_j) \right] \\ & + \sum_{t=1}^T \sum_{i \in I} \tau_i^{min}[t] (P_i^{min} - P_i^g[t]) + \sum_{t=1}^T \sum_{i \in I} \tau_t^{max}[t] (P_i^g[t] - P_i^{max}) \\ & + \sum_{t=1}^T \sum_{i \in I} \omega_i^{max}[t] (P_i^g[t] - P_i^g[t-1] - R_i) \\ & + \sum_{t=1}^T \sum_{i \in I} \omega_i^{min}[t] (P_i^g[t-1] - P_i^g[t] - R_i) \\ & + \sum_{t=1}^T \sum_{m \in M} \mu_m^{max}[t] \left(H_m(P_{[1:n]}^g[t] - P_{[1:n]}^l[t]) - F_m^{max} \right) \\ & + \sum_{t=1}^T \sum_{m \in M} \mu_m^{min}[t] \left(-F_m^{max} - H_m(P_{[1:n]}^g[t] - P_{[1:n]}^l[t]) \right) \end{aligned} \quad (4.53)$$

where $P_n^l[t] = \hat{P}_n^l[t]$ for $t = 1, \forall n$, and $P_n^l[t] = \hat{P}_n^l[t] + u_n[t]$ for $t > 1, \forall n$.

Ignoring the line flow constraints (4.50) and (4.51), and taking the partial deriva-

tive with respect to the current time step dispatch solution, we have

$$\begin{aligned} \frac{\partial \mathcal{L}}{\partial P_i^g[1]} &= \frac{\partial C_i^g(P_i^g[1])}{\partial P_i^g[1]} - \lambda - \tau_i^{min}[1] + \tau_i^{max}[1] \\ &\quad + \omega_i^{max}[1] - \omega_i^{max}[2] - \omega_i^{min}[1] + \omega_i^{min}[2] \end{aligned} \quad (4.54)$$

By the first order condition, setting the partial derivative to zero we get the locational marginal price (LMP) at the slack bus as

$$\lambda = \frac{\partial C_i^g(P_i^g[1])}{\partial P_i^g[1]} - \tau_i^{min}[1] + \tau_i^{max}[1] + \omega_i^{max}[1] - \omega_i^{max}[2] - \omega_i^{min}[1] + \omega_i^{min}[2] \quad (4.55)$$

We observe from (4.55) that the generator ramp limits corresponding to the next time step have an impact on the LMP value. Whereas in the conventional economic dispatch model since the future time steps are not considered these two terms will not exist in the breakdown of the LMP equation. When the future time step ramping constraints are not binding the LMPs in the robust dispatch case will match those in the conventional dispatch case.

4.4.3 Zonal Configuration and Ramp Requirements

Under current ISO procedures reserves are dispatched on a zonal basis. Reserve zones are usually divided on the basis of geography, utility boundaries or significant congested transmission lines. However, deliverability of reserves is a concern.

We assume that the scheduled imports and exports for a zone remain fixed. Thus we define the ramp capability for each zone as

$$\begin{aligned} RC_z[t] &= \text{Zonal Generator Ramp Power}[t] \\ &\quad + (\text{Imports}[t+1] - \text{Imports}[t]) - (\text{Exports}[t+1] - \text{Exports}[t]) \end{aligned} \quad (4.56)$$

where the Zonal Generator Ramp Power is the total available ramp capability from all the dispatched generators in a zone subject to inter-zonal tie-line flow limits. Thus accordingly we can calculate the zonal LORP as.

$$LORP_z^{up}[t] = Pr \left(\sum_{i \in I^z} P_i^g[t] + RC_z[t] < \tilde{P}_z^l[t + 1] \right), \forall z \quad (4.57)$$

Unlike the system-wide *LORP* here inter-zonal tie-line flow limits are considered.

Given the reserve zone groupings of the buses, we can calculate the $LORP_z$ for each zone for a given dispatch solution, while at the same time satisfying line flow limits on the tie-lines between the zones. This value can be used by the system operator as an index for the reliability of the dispatch solution with regards to the ramp capability in a particular zone. If the $LORP_z$ value is too high the operator may choose to import power from other zones or other ISOs in order to maintain ramp capability.

We can also define a system-wide LORP index as

$$LORP_s^{up}[t] = Pr \left(\sum_{i \in I} (P_i^g[t] + \min(R_i, P_i^{max} - P_i^g[t])) < \tilde{P}_s^l[t + 1] \right) \quad (4.58)$$

The difference between $LORP_s$ and $LORP_z$ is that $LORP_z$ uses the zonal ramp capability incorporating inter-zonal tie-line limits, whereas the system-wide index considers the total system ramp capability ignoring the tie-line limits.

We can use historical information from the past day of actual net load data for all the zones in the system. From this data we extract the mean, standard deviation and correlation information for the net load in all zones. Then using the correlation information we calculate the standard deviation of the net load uncertainty for the system using the following relationship.

$$\sigma^2\left(\sum_i x_i\right) = \sum_i \sigma^2(x_i) + \sum_{i \neq j} cov(x_i, x_j) \quad (4.59)$$

$$cov(x_i, x_j) = corr(x_i, x_j)\sigma(x_i)\sigma(x_j) \quad (4.60)$$

where $cov()$ is the covariance, $corr()$ is the correlation, σ represents the standard deviation of the random variable and σ^2 represents its variance.

Thus we can calculate σ_s from σ_z values. We can define the uncertainty set $U_s[t]$ for the system-wide uncertainty $u_s[t]$, similar to the definition for zonal case. This can be used to calculate the system-wide LORP.

4.4.4 Case Study

In this subsection a case study is presented on a modified 24 bus IEEE Reliability Test System (RTS) [82]. There are a total of 15 generators of which 3 are wind generators which we treat as negative load, while the rest are dispatchable (Fig. 4.7). Table 4.14 shows the parameters for the generators including maximum and minimum power output limits, offer costs and ramp rates. There are 32 transmission lines and the flow limits on all are assumed to be 200 MW. To ensure deliverability of ramp capability, for the future time intervals we neglect the intra-zonal transmission line flow limits by forming a reduced equivalent 4 bus network. For the reduced system we aggregate the generation and loads in each zone at a single bus. Thus the entire 24 bus system is reduced to 4 buses each representing one zone. In the reduced system the intra-zonal transmission line constraints are ignored while the inter-zonal flow limits are considered.

The simulation duration is 24 hours with dispatch performed for 5-min intervals, using scaled real load profile data taken from New York ISO [83]. The uncertainty

set for the net load in each zone is defined by considering deviations of $\pm 2.5\sigma_z$ from the forecast net load values. The standard deviation σ_z for each zone is obtained from the previous day's actual net load data. The robust optimization dispatch is modeled and solved in MATLAB using *linprog* solver and the YALMIP toolbox [63].

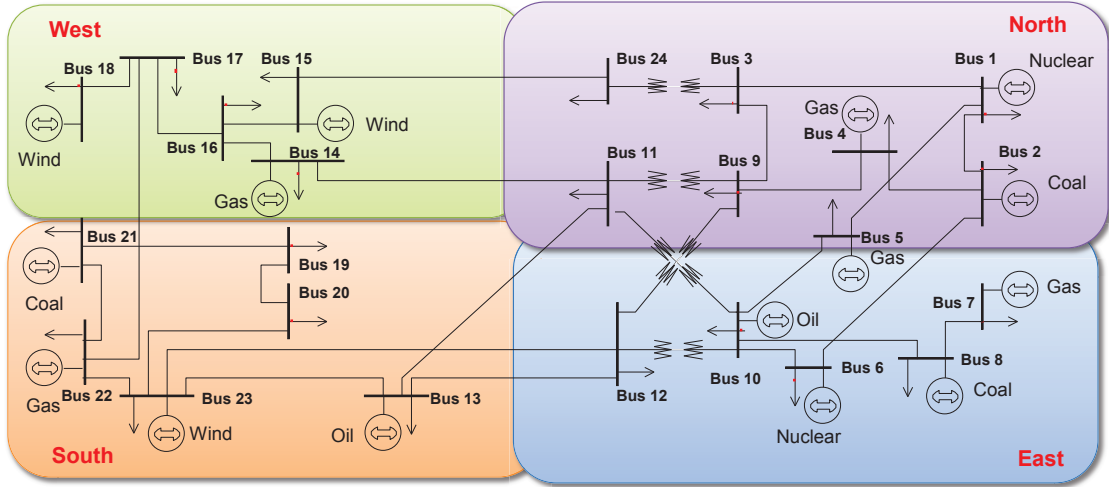

Figure 4.7: Modified IEEE 24 bus RTS system

Fig. 4.8 shows the total electric load for the system for the entire day.

The real-time economic dispatch is simulated using the conventional model, the look-ahead model and the robust model ($T=2$). Fig. 4.9 shows the total wind power output for the system. In these simulations wind is considered as a negative load, and it is assumed that wind is not curtailed. Assuming no imports and exports from outside the system the Net Load faced by the generators is the difference between the electrical load and the wind. The total electrical load and the total net load profiles are shown in Fig. 4.10.

The generation profiles of the different fuel types for conventional and robust dispatch are shown in Fig. 4.11 (Gas), Fig. 4.12 (Nuclear), Fig. 4.13 (Coal) and

Table 4.14: Generator parameters for IEEE 24 bus system

Bus	Type	P^{max} MW	P^{min} MW	Cost \$/MWh	Ramp Rate % MW/min	Zone
1	Nuclear	140	50	15	0.8	N
2	Coal	540	40	20	2	N
4	Gas	300	30	40	5	N
5	Gas	510	25	27	6.5	N
6	Nuclear	150	45	14	0.9	E
7	Gas	490	24	49	7	E
8	Coal	165	15	23	1.9	E
10	Oil	60	0	250	20	E
13	Oil	90	0	220	20	S
14	Gas	170	34	48	9	W
15	Wind	200	0	4	9	W
18	Wind	240	0	6	10	W
21	Coal	300	30	21	1.8	S
22	Gas	725	50	36	11	S
23	Wind	70	0	5	11	S

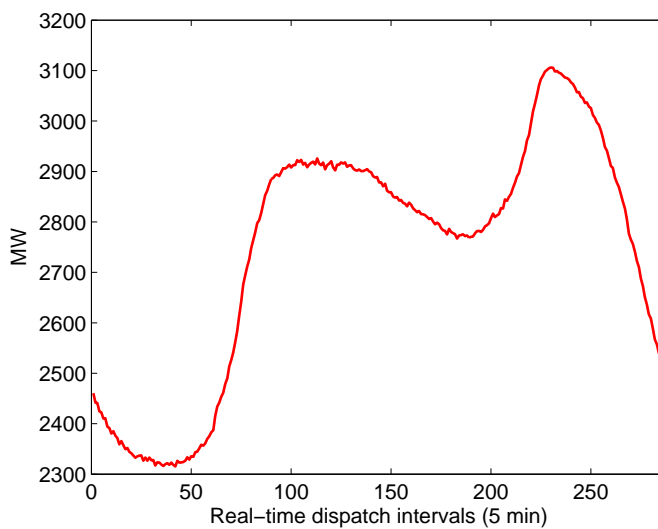

Figure 4.8: System total electric load profile for entire day

Fig. 4.14 (Oil-fired Peakers).

It is observed that the conventional dispatch relies to a greater extent on the

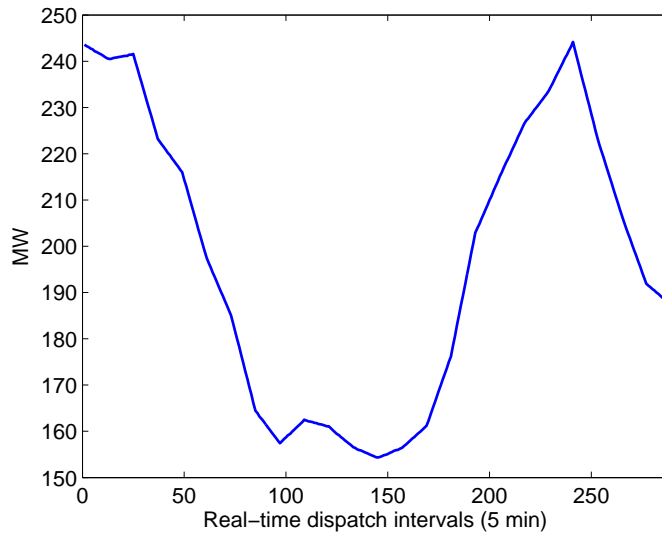

Figure 4.9: System total wind profile for entire day

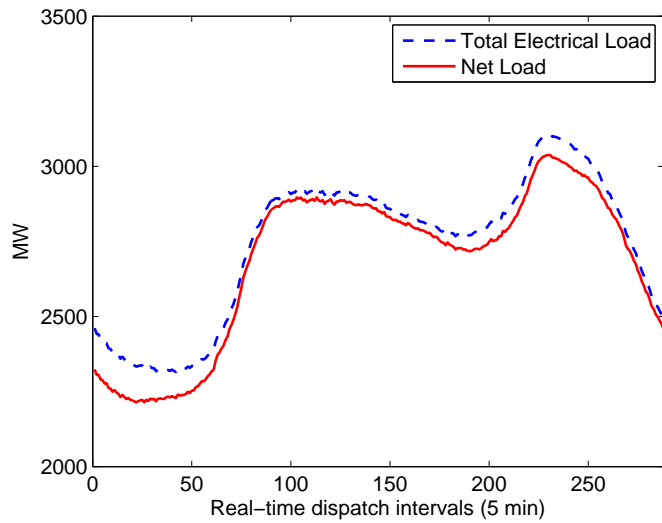

Figure 4.10: System total electrical load and net load profiles for entire day

Gas generators to meet the system peak net load, whereas in the robust dispatch they are backed down. This is done to provide additional ramp capability from fast ramping units. At the same time the robust dispatch does not back down the nuclear

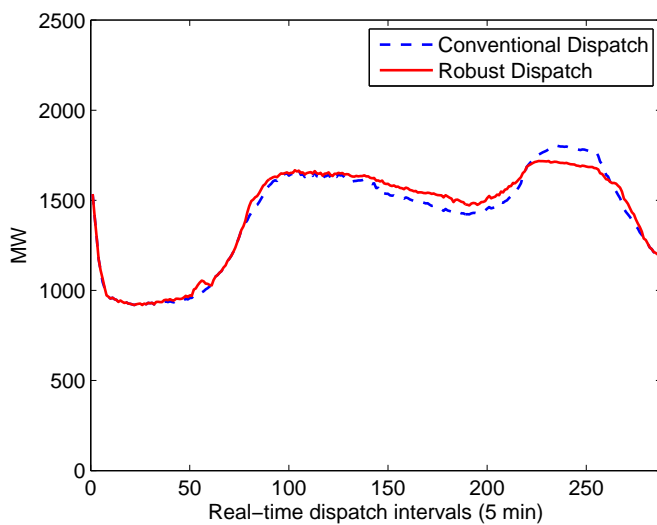

Figure 4.11: System total gas generator profile for entire day

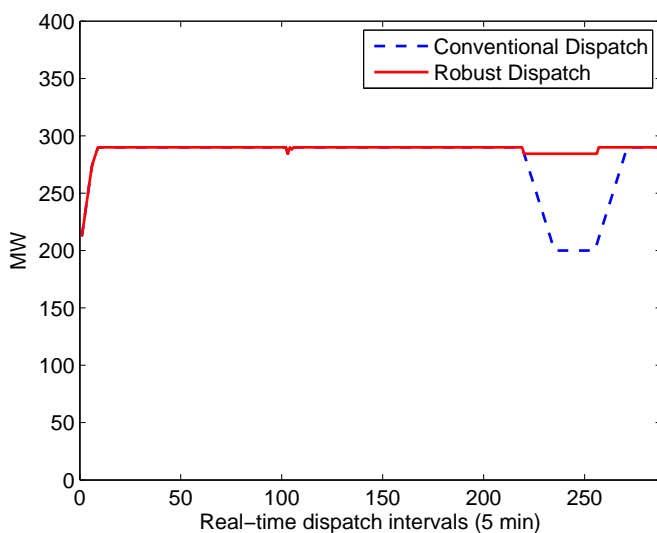

Figure 4.12: System total nuclear generator profile for entire day

generators as is done in the conventional dispatch approach.

For most of the non peak load intervals the robust model dispatches more power from Gas, whereas the conventional model relies more on Coal generators. It can be seen that the robust dispatch model will have an impact on the dispatch of different

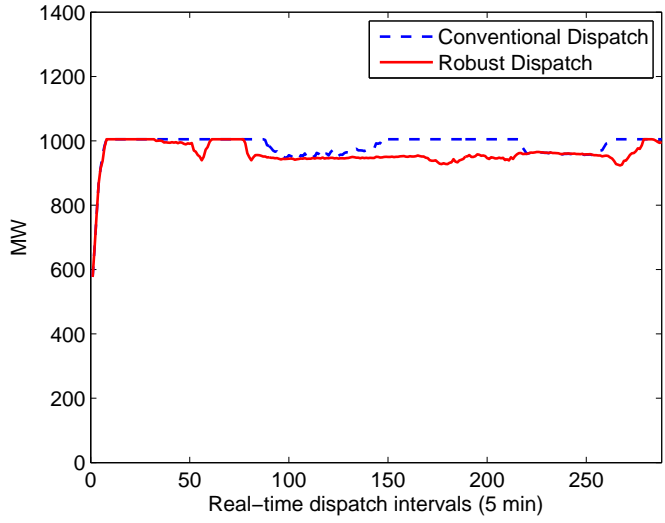

Figure 4.13: System total coal generator profile for entire day

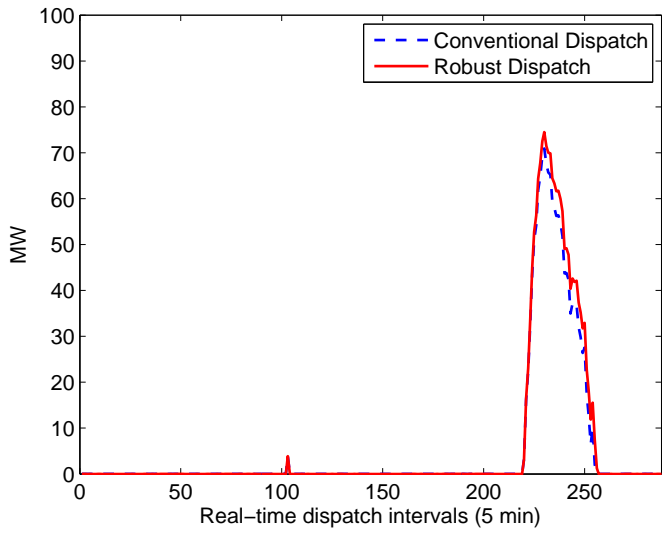

Figure 4.14: System total peaker (oil-fired) profile for entire day

types of generators depending on their ramp rates. Thus, it will have an impact on emissions relative to the conventional dispatch model, for a given generation portfolio.

Fig. 4.15 shows the comparison of the dispatch costs for all the generators (except

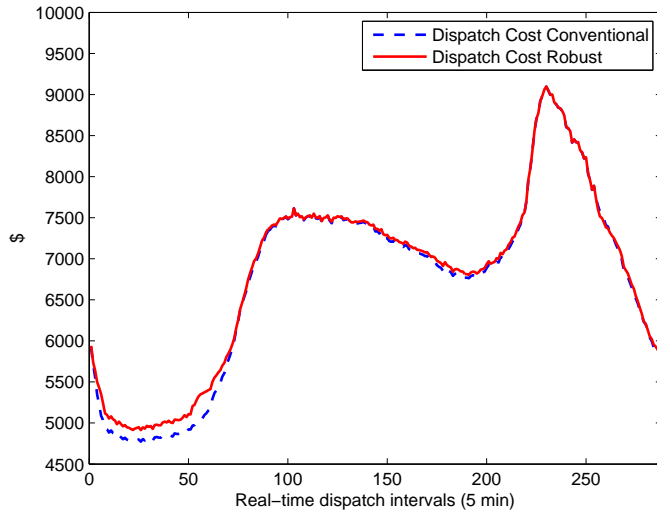

Figure 4.15: System dispatch costs for entire day

wind) for both the conventional and robust dispatch simulations. The costs are close for most of the day but it can be seen that the costs for the robust dispatch are higher. This is as expected since the robust solution is in general more conservative. The dispatch costs in robust dispatch depend on the uncertainty set. For smaller size of uncertainty set the robust dispatch costs will be lower.

Fig. 4.16 compares the LORP of the North zone of the IEEE 24 bus RTS for the conventional and the robust dispatch approach for the entire day of real time dispatch simulation. Similarly Fig. 4.17 shows the LORPs of the the conventional and robust model for the entire day for the East zone. For the North zone while both the LORPs are low the robust model gives much lower LORPs in most time intervals compared to the conventional approach indicating that the procurement of ramp capability in the North zone is greater under the robust model. While in the East zone due to peak loading the ramp capability for both approaches is the same for many time intervals during the day. The average LORP values for both zones are lower with the robust model than the conventional model indicating that the robust

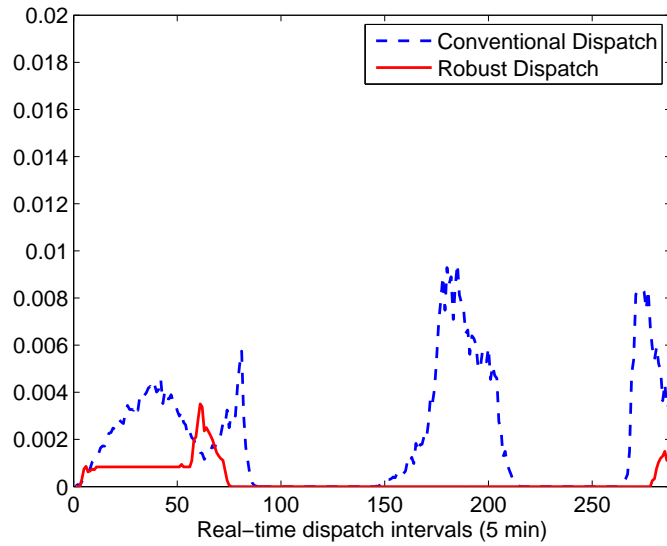

Figure 4.16: North zone LORP for entire day

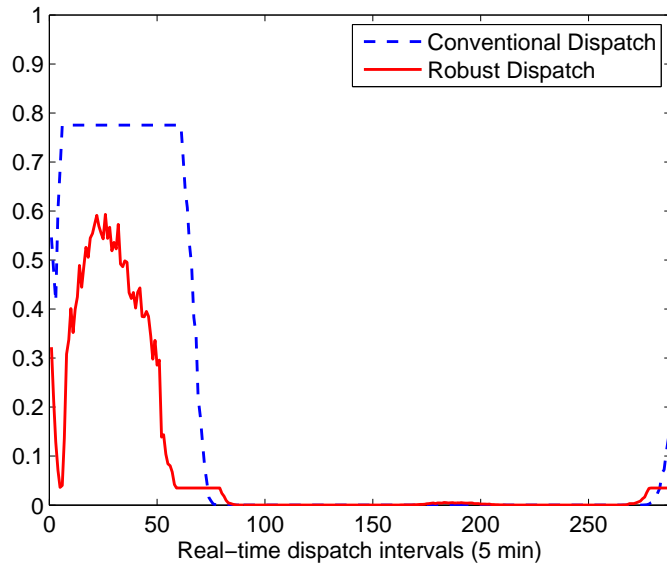

Figure 4.17: East zone LORP for entire day

approach is more reliable in regards to ramp capability.

Fig. 4.18 shows the mean LORP index values for the day for the North and South zones, whereas Fig. 4.19 shows the mean LORP values for the East and West

zones. The robust approach has lower LORP values than both conventional as well as look-ahead dispatch. Thus, it is more reliable in terms of zonal ramp capability.

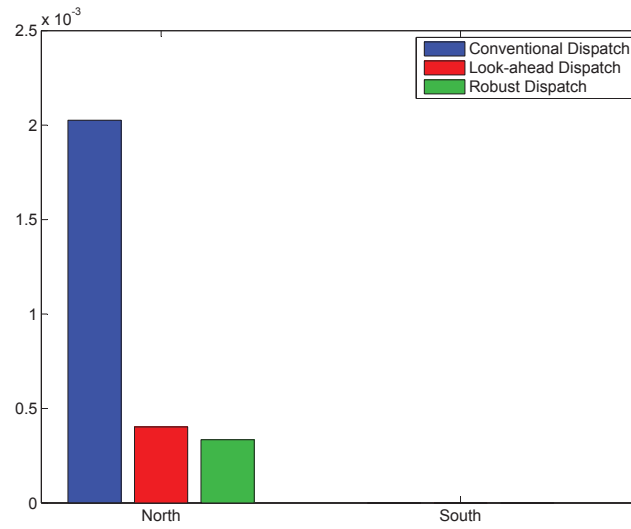

Figure 4.18: Mean LORP comparison for north and south zones

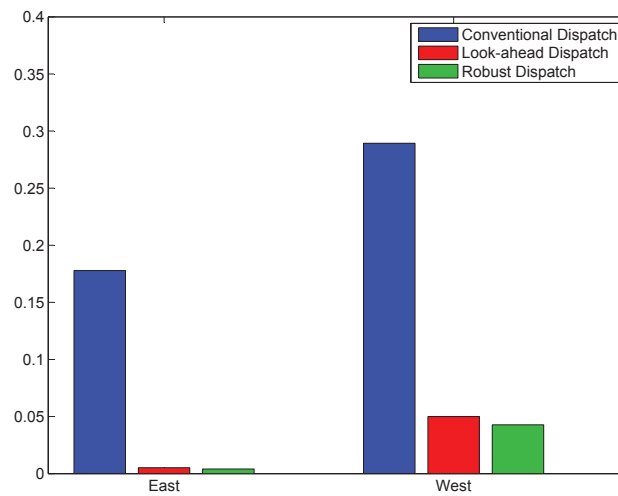

Figure 4.19: Mean LORP comparison for east and west zones

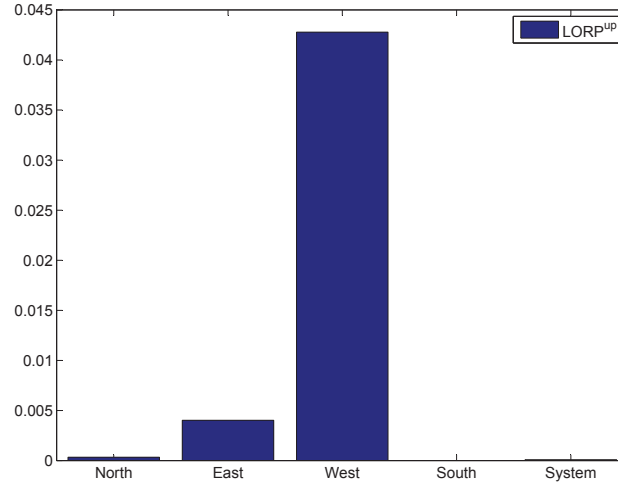

Figure 4.20: Mean LORP comparison for different zones using robust dispatch

Fig. 4.20 shows the system-wide LORP as well as the zonal LORP values. The system-wide value is low, however it does not give a complete picture of the ramp capability since it does not consider inter-zonal tie-line flow limits.

Thus we can calculate the $LORP_z$ for each zone for a given dispatch solution, while at the same time satisfying line flow limits on the tie-lines between the zones. This value can be used by the system operator as an index for the flexibility of the dispatch solution with regards to the ramp capability in a particular zone. If the $LORP_z$ value is too high the operator may choose to take some action to maintain dispatch flexibility.

The proposed robust optimization based economic dispatch model is implementable in multi-zonal systems and ensures the deliverability of procured ramp capability between operating zones.

5. CONCLUSIONS

This dissertation introduces a robust optimization-based decision making framework in electric power systems with high penetration of variable renewable resources. The notion of risk is included in the decision making framework to provide the decision maker with a reliable as well as cost effective decision. Both the problems of market participant's bidding and of system operator's scheduling are formulated using robust optimization. For the case of the market participant's bidding, the risk is related to the loss of revenue in the sales of electricity due to uncertainty from renewable resources as well as uncertainty in electricity market clearing price. From the system operator's point of view the risk is related to power shortages when the system power balance requirement is not met due to inadequate system ramp capability. In both cases there is a trade-off between the optimality of the solution in terms of profit or cost versus the risk.

In Section 2 we discuss robust optimization and provide background on power system scheduling. In Section 3 we discuss the robust optimization-based bidding strategy formulation for the combination of a wind farm and energy storage acting as a price taking market participant. In Section 4 we discuss the robust economic dispatch model from the perspective of the independent system operator making the optimal dispatch decision for all the conventional generators in the system. The conclusions and proposed future work for both of these problems are discussed in the following two subsections.

5.1 Robust Optimization Based Bidding Strategy

5.1.1 Summary

Section 3 presents the application of robust optimization to determine the optimal bidding strategy for the combination of a wind farm and energy storage, under uncertainty due to wind power forecast error and electricity market clearing price forecast error. The wind farm combined with an on-site energy storage device can bid into the day-ahead electricity market. The combination of wind and storage leads to better utilization of the uncertain wind resource and increased economic performance through participation in price arbitrage.

In the worst case scenario of wind power forecast error and electricity price forecast error, the robust optimization based bidding strategy gives a better economic performance than the deterministic approach. However, when forecast error is low the robust optimization based approach gives a more conservative result. Further, the robust optimization based strategy has an increasing probability of yielding better economic performance than the deterministic approach as the forecast error in electricity price increases. This is important because wind producers who bid into day-ahead electricity markets have to deal with uncertainty due to large forecast errors.

As compared to stochastic optimization the robust approach gives a more conservative result. But the advantage of the robust optimization approach is that it does not require detailed information about the probability distribution of the uncertain variable. Further, the robust linear programming problem is computationally tractable and requires significantly lower computational effort than the stochastic approach. The conservatism of the robust method can be adjusted by changing the size of the uncertainty set selected. The robust approach also ensures feasibility of

the solution for all realizations of the uncertain variable that fall within the chosen uncertainty set.

The uncertainty set for the robust optimization approach can be determined based on historical data of forecast error of the uncertain variable as well as the decision maker's risk preference. The uncertainty set can be defined based on risk measures commonly used in the finance industry.

The economic performance of the bidding strategy is evaluated using Monte Carlo simulations by making suitable assumptions about the probability distribution of the electricity price and wind power forecast errors.

5.1.2 Future Work

This work opens the door for many future research opportunities. One direction is to investigate the coupling between longer-term hour-ahead and shorter-term real-time markets in a model predictive control manner. Another research direction is the application of the robust method for obtaining the bidding strategy for multi-stage markets, such as the day-ahead and real-time electricity markets common in US ISOs. In order to improve the utilization of the renewable resource other applications of the renewable generator and energy storage combination could also be considered, including ancillary services such as frequency regulation.

5.2 Robust Optimization Based Economic Dispatch

5.2.1 Summary

In Section 4 we propose and evaluate a robust optimization based approach to managing system ramping requirement in real-time economic dispatch. The robust model is compared both with the existing conventional economic dispatch model as well as with a new model recently proposed by the industry called ramp product. In order to assess the performance of different dispatch models targeted at managing the

increasing system-wide ramping requirements, we propose Lack of Ramp Probability (LORP) as a flexibility metric. This index measures the probability of insufficient system ramp capability event occurring, thereby resulting in system power supply-demand imbalance.

The trade-off of reliability and dispatch cost for both the ramp product approach as well as the robust approach is shown through a numerical on a simple test system. Additionally, the generation dispatch costs and reliability of dispatch are evaluated using Monte Carlo simulations for both the ramp product model as well as the robust economic dispatch model. It is shown that our proposed robust model yields a higher reliability of dispatch as well as lower mean and variability of generation dispatch cost relative to the ramp product model for the same level of uncertainty in net load.

Further, in this dissertation a robust economic dispatch model including inter-zonal tie-line flow limits is proposed. The proposed formulation is demonstrated through a case study on a multi-zonal IEEE 24 bus Reliability Test System. The robust model is compared to the deterministic economic dispatch model as well as the look-ahead economic dispatch model in terms of dispatch costs and the proposed LORP index. The proposed robust economic dispatch model is implementable in multi-zonal systems and ensures the deliverability of procured ramp capability between operating zones.

5.2.2 Future Work

Based on the work in this dissertation a future avenue of research could be to construct a proper market mechanism that enables the implementation of the robust dispatch with guaranteed system ramping capability.

Another direction is the multi-objective optimization based dispatch which considers both cost and emissions. The robust framework can also be applied to address

the coordination of both conventional generation and renewables with new technologies such as Plug-in Hybrid Electric Vehicles (PHEVs) and Demand Response. The uncertainties involved in decision making in such applications include those arising from consumer behavior. The risk aware robust decision making framework is suitable if the consumers are assumed to be risk averse.

REFERENCES

- [1] A. A. Thatte, F. Zhang, and L. Xie, “Coordination of wind farms and flywheels for energy balancing and frequency regulation,” in *Proceedings of the IEEE Power and Energy Society General Meeting*, (Detroit, MI), pp. 1–7, July 24–29, 2011.
- [2] A. A. Thatte and L. Xie, “Towards a unified operational value index of energy storage in smart grid environment,” *IEEE Transactions on Smart Grid*, vol. 3, pp. 1418–1426, Sept. 2012.
- [3] A. Shapiro, “Stochastic programming by Monte Carlo simulation methods,” tech. rep., Humboldt University Berlin, Germany, 2000. Available: <http://edoc.hu-berlin.de/series/speps/2000-3/PDF/3.pdf>.
- [4] A. Ben-Tal and A. Nemirovski, “Robust solutions of uncertain linear programs,” *Operations Research Letters*, vol. 25, no. 1, pp. 1–13, 1999.
- [5] D. Bertsimas and D. B. Brown, “Constructing uncertainty sets for robust linear optimization,” *Operations Research*, vol. 57, no. 6, pp. 1483–1495, 2009.
- [6] A. J. Conejo, F. J. Nogales, and J. M. Arroyo, “Price-taker bidding strategy under price uncertainty,” *IEEE Transactions on Power Systems*, vol. 17, pp. 1081–1088, Nov. 2002.
- [7] G. N. Bathurst and G. Strbac, “Value of combining energy storage and wind in short-term energy and balancing markets,” *Electric Power Systems Research*, vol. 67, no. 1, pp. 1 – 8, 2003.
- [8] E. D. Castronuovo and J. A. P. Lopes, “On the optimization of the daily operation of a wind-hydro power plant,” *IEEE Transactions on Power Systems*,

- vol. 19, pp. 1599–1606, Aug. 2004.
- [9] S. J. Kazempour, M. Hosseinpour, and M. P. Moghaddam, “Self-scheduling of a joint hydro and pumped-storage plants in energy, spinning reserve and regulation markets,” in *Proceedings of the IEEE Power and Energy Society General Meeting*, (Calgary, AB, Canada), pp. 1–8, July 26-30, 2009.
- [10] M. Korpaas, A. T. Holen, and R. Hildrum, “Operation and sizing of energy storage for wind power plants in a market system,” *International Journal of Electrical Power & Energy Systems*, vol. 25, no. 8, pp. 599 – 606, 2003.
- [11] N. Lu, J. H. Chow, and A. A. Desrochers, “Pumped-storage hydro-turbine bidding strategies in a competitive electricity market,” *IEEE Transactions on Power Systems*, vol. 19, no. 2, pp. 834–841, 2004.
- [12] E. Mashhour and S. M. Moghaddas-Tafreshi, “Bidding strategy of virtual power plant for participating in energy and spinning reserve markets - Part I: problem formulation,” *IEEE Transactions on Power Systems*, vol. 26, pp. 949–956, May 2011.
- [13] S.-E. Fleten and T. K. Kristoffersen, “Stochastic programming for optimizing bidding strategies of a nordic hydropower producer,” *European Journal of Operational Research*, vol. 181, no. 2, pp. 916–928, 2007.
- [14] J. Garcia-Gonzalez, R. M. R. de la Muela, L. M. Santos, and A. M. Gonzalez, “Stochastic joint optimization of wind generation and pumped-storage units in an electricity market,” *IEEE Transactions on Power Systems*, vol. 23, pp. 460–468, May 2008.
- [15] R. Nürnberg and W. Römisch, “A two-stage planning model for power scheduling in a hydro-thermal system under uncertainty,” *Optimization and Engineer-*

- ing, vol. 3, pp. 355–378, 2002.
- [16] Y. Yuan, Q. Li, and W. Wang, “Optimal operation strategy of energy storage unit in wind power integration based on stochastic programming,” *IET Renewable Power Generation*, vol. 5, pp. 194–201, Mar. 2011.
- [17] EPRI, “Electric energy storage technology options: A white paper primer on applications, costs, and benefits. epri white paper 1020676,” *EPRI, Palo Alto, CA*, 2010.
- [18] B. Daryanian and R. E. Bohn, “Sizing of electric thermal storage under real time pricing,” *IEEE Transactions on Power Systems*, vol. 8, pp. 35–43, Feb. 1993.
- [19] F. C. Schweppe, R. D. Tabors, J. L. Kirtley, H. R. Outhred, F. H. Pickel, and A. J. Cox, “Homeostatic utility control,” *IEEE Transactions on Power Apparatus and Systems*, vol. PAS-99, pp. 1151–1163, May 1980.
- [20] A. Molina-Garcia, F. Bouffard, and D. S. Kirschen, “Decentralized demand-side contribution to primary frequency control,” *IEEE Transactions on Power Systems*, vol. 26, pp. 411–419, Feb. 2011.
- [21] A. J. Conejo, J. M. Morales, and L. Baringo, “Real-time demand response model,” *IEEE Transactions on Smart Grid*, vol. 1, pp. 236–242, Dec. 2010.
- [22] M. D. Ilić, J.-Y. Joo, L. Xie, M. Prica, and N. Roterling, “A decision-making framework and simulator for sustainable electric energy systems,” *IEEE Transactions on Sustainable Energy*, vol. 2, pp. 37–49, Jan. 2011.
- [23] F. Rahimi and A. Ipakchi, “Demand response as a market resource under the smart grid paradigm,” *IEEE Transactions on Smart Grid*, vol. 1, pp. 82–88, June 2010.

- [24] J. D. Rogers, R. I. Schermer, B. L. Miller, and J. F. Hauer, “30-MJ superconducting magnetic energy storage system for electric utility transmission stabilization,” *Proceedings of the IEEE*, vol. 71, pp. 1099–1107, Sept. 1983.
- [25] A. A. Thatte, F. Zhang, and L. Xie, “Coordination of wind farms and flywheels for energy balancing and frequency regulation,” in *Proceedings of the IEEE Power and Energy Society General Meeting*, (Detroit, MI), pp. 1–7, July 24–29, 2011.
- [26] M. Black and G. Strbac, “Value of bulk energy storage for managing wind power fluctuations,” *IEEE Transactions on Energy Conversion*, vol. 22, pp. 197–205, Mar. 2007.
- [27] P. Denholm and R. Sioshansi, “The value of compressed air energy storage with wind in transmission-constrained electric power systems,” *Energy Policy*, vol. 37, no. 8, pp. 3149–3158, 2009.
- [28] Y. M. Atwa and E. F. El-Saadany, “Optimal allocation of ESS in distribution systems with a high penetration of wind energy,” *IEEE Transactions on Power Systems*, vol. 25, pp. 1815–1822, Nov. 2010.
- [29] D. S. Kirschen, “Demand-side view of electricity markets,” *IEEE Transactions on Power Systems*, vol. 18, pp. 520–527, May 2003.
- [30] K. Natarajan, D. Pachamanova, and M. Sim, “Constructing risk measures from uncertainty sets,” *Operations Research*, vol. 57, no. 5, pp. 1129–1141, 2009.
- [31] L. Xie, P. M. S. Carvalho, L. A. F. M. Ferreira, J. Liu, B. H. Krogh, N. Popli, and M. D. Ilić, “Wind integration in power systems: operational challenges and possible solutions,” *Proceedings of the IEEE*, vol. 99, pp. 214–232, Jan. 2011.

- [32] S. Takriti, B. Krasenbrink, and L. S.-Y. Wu, “Incorporating fuel constraints and electricity spot prices into the stochastic unit commitment problem,” *Operations Research*, vol. 48, no. 2, pp. 268–280, 2000.
- [33] M. P. Nowak, R. Schultz, and M. Westphalen, “A stochastic integer programming model for incorporating day-ahead trading of electricity into hydro-thermal unit commitment,” *Optimization and Engineering*, vol. 6, pp. 163–176, 2005. 10.1007/s11081-005-6794-0.
- [34] N. P. Padhy, “Unit commitment-a bibliographical survey,” *IEEE Transactions on Power Systems*, vol. 19, no. 2, pp. 1196–1205, 2004.
- [35] V. Gabrel, C. Murat, and A. Thiele, “Recent advances in robust optimization and robustness: An overview,” tech. rep., LAMSADE, Universite Paris-Dauphine, Paris, France, 2012. Available: http://www.optimization-online.org/DB_HTML/2012/07/3537.html.
- [36] D. Bertsimas, E. Litvinov, X. A. Sun, J. Zhao, and T. Zheng, “Adaptive robust optimization for the security constrained unit commitment problem,” *IEEE Transactions on Power Systems*, vol. 28, pp. 52–63, Feb. 2013.
- [37] M. Zhang and Y. Guan, “Two-stage robust unit commitment problem,” tech. rep., University of Florida, Gainesville, FL, 2009.
- [38] L. Zhao and B. Zeng, “Robust unit commitment problem with demand response and wind energy,” tech. rep., University of South Florida, Tampa, FL, 2010.
- [39] R. Jiang, M. Zhang, G. Li, and Y. Guan, “Two-stage robust power grid optimization problem,” tech. rep., 2010. Available: http://www.optimization-online.org/DB_HTML/2010/10/2769.html.

- [40] R. Jiang, J. Wang, and Y. Guan, “Robust unit commitment with wind power and pumped storage hydro,” *IEEE Transactions on Power Systems*, vol. 27, pp. 800–810, May 2012.
- [41] D. B. Patton, “2010 state of the market report Midwest ISO,” tech. rep., Potomac Economics, Midwest ISO Independent Market Monitor, Carmel, IN, May 2011. Available: https://www.potomaceconomics.com/uploads/midwest-presentations/2010_State_of_the_Market_Presentation_-_Final.pdf.
- [42] N. Navid and G. Rosenwald, “Ramp capability product design,” tech. rep., MISO, Carmel, IN, July 2013. Available: <https://www.misoenergy.org/Library/Repository/CommunicationMaterial/KeyPresentationsandWhitepapers/RampProductConceptualDesignWhitepaper.pdf>.
- [43] L. Xu and D. Tretheway, “Flexible ramping products,” *CAISO Proposal*, Oct. 2012. Available: <http://www.caiso.com/Documents/SecondRevisedDraftFinalProposal-FlexibleRampingProduct.pdf>.
- [44] D. Bertsimas, D. Brown, and C. Caramanis, “Theory and applications of robust optimization,” *Arxiv preprint arXiv:1010.5445*, 2010.
- [45] D. Pachamanova, *A Robust Optimization Approach to Finance*. PhD thesis, Massachusetts Institute of Technology, Cambridge, MA, 2002.
- [46] D. Bertsimas and M. Sim, “The price of robustness,” *Operations Research*, vol. 52, no. 1, pp. 35–53, 2004.
- [47] G. Lagos, D. Espinoza, E. Moreno, and J. Amaya, “Robust planning for an open-pit mining problem under ore-grade uncertainty,” *Electronic Notes in Discrete Mathematics*, vol. 37, no. 0, pp. 15 – 20, 2011.

- [48] A. J. Conejo, R. Garcia-Bertrand, M. Carrion, A. Caballero, and A. de Andres, “Optimal involvement in futures markets of a power producer,” *IEEE Transactions on Power Systems*, vol. 23, pp. 703–711, May 2008.
- [49] P. Artzner, F. Delbaen, J. M. Eber, and D. Heath, “Coherent measures of risk,” *Mathematical Finance*, vol. 9, no. 3, pp. 203–228, 1999.
- [50] R. T. Rockafellar, “Coherent approaches to risk in optimization under uncertainty,” *Tutorials in Operations Research, INFORMS*, pp. 38–61, 2007. Available: <http://pubsonline.informs.org/doi/pdf/10.1287/educ.1073.0032>.
- [51] R. T. Rockafellar and S. Uryasev, “Optimization of conditional value-at-risk,” *Journal of Risk*, vol. 2, pp. 21–42, 2000.
- [52] M. Ilić, “From hierarchical to open access electric power systems,” *Proceedings of the IEEE*, vol. 95, pp. 1060–1084, May 2007.
- [53] J. Zaborszky, “A large system approach toward operating the electric power system by decision and control,” in *American Control Conference*, pp. 1143–1155, June 1984.
- [54] M. D. Ilić and J. Zaborszky, *Dynamics and Control of Large Electric Power Systems*. New York: Wiley Interscience, 2000.
- [55] B. J. Kirby, “Frequency regulation basics and trends,” Tech. Rep. ORNL/TM-2004/291, Oak Ridge National Laboratory, Dec. 2005.
- [56] North American Electric Reliability Council (NERC), “Real power balancing control performance,” *NERC BAL-001-0a*, 2008.
- [57] P. Sullivan, W. Short, and N. Blair, “Modeling the benefits of storage technologies to wind power,” *Wind Engineering*, vol. 32, no. 6, pp. 603–615, 2008.

- [58] T. Zheng, J. Zhao, E. Litvinov, and F. Zhao, “Robust optimization and its application to power system operation,” in *Proceedings of CIGRÉ SC C2 Session*, (Paris, France), Aug. 26-31, 2012.
- [59] E. F. Camacho and C. Bordons, *Model predictive control*. New York: Springer Verlag, 2 ed., 2004.
- [60] L. Xie and M. Ilić, “Model predictive dispatch in electric energy systems with intermittent resources,” in *Proceedings of the IEEE International Conference on Systems, Man and Cybernetics*, pp. 42–47, Oct. 2008.
- [61] Y. Gu and L. Xie, “Look-ahead coordination of wind energy and electric vehicles: a market-based approach,” in *Proceedings of the 42nd North American Power Symposium*, (Arlington, TX), Sept. 26-28, 2010.
- [62] M. Kraning, Y. Wang, E. Akuiyibo, and S. Boyd, “Operation and configuration of a storage portfolio via convex optimization,” in *Proceedings of the 18th IFAC World Congress*, vol. 18, (Milano, Italy), pp. 10487–10492, 2011.
- [63] J. Löfberg, “Modeling and solving uncertain optimization problems in YALMIP,” in *Proceedings of the 17th IFAC World Congress*, pp. 1337–1341, 2008.
- [64] B. Hodge and M. Milligan, “Wind power forecasting error distributions over multiple timescales,” in *Proceedings of the IEEE Power and Energy Society General Meeting*, (Detroit, MI), pp. 1–8, July 24-28, 2011.
- [65] W. K. Gatterbauer, “Interdependencies of electricity market characteristics and bidding strategies of power producers,” Master’s thesis, Massachusetts Institute of Technology, Cambridge, MA, 2002.

- [66] L. J. Hong and G. Liu, “Monte carlo estimation of value-at-risk, conditional value-at-risk and their sensitivities,” in *Proceedings of the Winter Simulation Conference (WSC)*, (Phoenix, AZ), pp. 95–107, Dec. 11-14, 2011.
- [67] A. A. Thatte, D. E. Viassolo, and L. Xie, “Robust bidding strategy for wind power plants and energy storage in electricity markets,” in *Proceedings of the IEEE Power and Energy Society General Meeting*, (San Diego, CA), pp. 1–8, July 22-26, 2012.
- [68] J. Zack, “Overview of wind energy generation forecasting,” Draft report for NY state energy research and development authority and for NY ISO, True Wind Solutions LLC, Albany, NY, 2003.
- [69] K. Porter and J. Rogers, “Status of centralized wind power forecasting in north america,” Tech. Rep. NREL/SR-550-47853, National Renewable Energy Laboratory, Golden, CO, 2010.
- [70] K.-H. Ahlert and C. Block, “Assessing the impact of price forecast errors on the economics of distributed storage systems,” in *Proceedings of the 43rd Hawaii International Conference on System Sciences (HICSS)*, (Honolulu, HI), pp. 1–10, Jan. 5-8, 2010.
- [71] D. Bertsimas and A. Thiele, “Robust and data-driven optimization: modern decision-making under uncertainty,” *Tutorials in Operations Research: Models, Methods, and Applications for Innovative Decision Making, INFORMS*, pp. 95–122, 2006. Available: <http://pubsonline.informs.org/doi/pdf/10.1287/educ.1063.0022>.
- [72] J. B. Bremnes, “Probabilistic wind power forecasts using local quantile regression,” *Wind Energy*, vol. 7, no. 1, pp. 47–54, 2004.

- [73] Y. V. Makarov, C. Loutan, J. Ma, and P. de Mello, “Operational impacts of wind generation on California power systems,” *IEEE Transactions on Power Systems*, vol. 24, pp. 1039–1050, May 2009.
- [74] R. G. de Almeida and J. A. P. Lopes, “Participation of doubly fed induction wind generators in system frequency regulation,” *IEEE Transactions on Power Systems*, vol. 22, pp. 944–950, Aug. 2007.
- [75] N. Navid, G. Rosenwald, and D. Chatterjee, “Ramp capability for load following in the MISO markets,” *MISO Whitepaper*, July 2011. Available: https://www.misoenergy.org/_layouts/MISO/ECM/Redirect.aspx?ID=112806.
- [76] P. R. Gribik, D. Chatterjee, and N. Navid, “Potential new products and models to improve an rto’s ability to manage uncertainty,” in *Proceedings of the IEEE Power and Energy Society General Meeting*, (San Diego, CA), pp. 1–5, July 22-26, 2012.
- [77] Y. Gu and L. Xie, “Look-ahead dispatch with forecast uncertainty and infeasibility management,” in *Proceedings of the IEEE Power and Energy Society General Meeting*, pp. 1–7, July 22-26, 2012.
- [78] D.-H. Choi and L. Xie, “Ramp-induced data attacks on look-ahead dispatch in real-time power markets,” *IEEE Transactions on Smart Grid*, vol. 4, pp. 1235 – 1243, Sept. 2013.
- [79] “PJM generation adequacy analysis: Technical methods,” tech. rep., PJM Interconnection, Oct. 2003. Available: <http://www.pjm.com/~media/etools/oasis/references/whitepaper-sections-12.ashx>.
- [80] N. Navid and G. Rosenwald, “Market solutions for managing ramp flexibility with high penetration of renewable resource,” *IEEE Transactions on Sustainable*

- Energy*, vol. 3, pp. 784–790, Oct. 2012.
- [81] D. Shi and D. J. Tylavsky, “An improved bus aggregation technique for generating network equivalents,” in *Proceedings of the IEEE Power and Energy Society General Meeting*, (San Diego, CA), pp. 1–8, July 22-26, 2012.
- [82] Y. Gu and L. Xie, “Early detection and optimal corrective measures of power system insecurity in enhanced look-ahead dispatch,” *IEEE Transactions on Power Systems*, vol. 28, pp. 1297–1307, May 2013.
- [83] NYISO, “New York ISO: Market and operational data - load data,” Available: http://www.nyiso.com/public/markets_operations/market_data/load_data/index.jsp.