

**SMART SHELTER: A SUSTAINABLE POWER SYSTEM DESIGN USING
MICRO-ENERGY HARVESTING TECHNIQUES**

An Undergraduate Research Scholars Thesis

by

BEN HILTON, LETICIA IBARRA, MEHNA NAWAL

Submitted to Honors and Undergraduate Research
Texas A&M University
In partial fulfillment of the requirements for the designation as an

UNDERGRADUATE RESEARCH SCHOLAR

Approved by
Research Advisor:

Dr. Edgar Sanchez-Sinencio

May 2014

Major: Electrical Engineering

TABLE OF CONTENTS

	Page
ABSTRACT.....	1
ACKNOWLEDGEMENTS.....	3
NOMENCLATURE	4
CHAPTER	
I. INTRODUCTION OF ENERGY HARVESTING SYSTEMS	5
Energy Harvesting	7
Solar Energy Harvesting.....	11
Thermal Energy Harvesting.....	13
Kinetic Energy Harvesting.....	16
Rf Energy Harvesting	20
II. POWER SYSTEM DESIGN & SIMULATED RESULTS	24
Subsystem 1: Solar Module Design.....	26
Subsystem 2: Thermal Module Design.....	31
Subsystem 3: Kinetic Module Design	33
Subsystem 4: Radio-Frequency Module Design.....	38
Subsystem 5: Power Management Unit Design.....	41
III. ACTUAL POWER SYSTEM RESULTS & COMPARISON.....	46
Subsystem 1: Solar Module Results & Comparison.....	46
Subsystem 2: Thermal Module Results & Comparison.....	48
Subsystem 3: Kinetic Module Results & Comparison	49
Subsystem 4: Radio-Frequency Module Results & Comparison	50
Subsystem 5: Control Circuit Design	53
IV. CONCLUSIONS AND FUTURE WORK.....	56
REFERENCES	57

ABSTRACT

Smart Shelter: A Sustainable Power System Design Using Micro-Energy Harvesting Techniques.
(May 2014)

Ben Hilton, Leticia Ibarra, Mehna Nawal
Department of Electrical And Computer Engineering
Texas A&M University

Research Advisor: Dr. Edgar Sanchez-Sinencio
Department of Electrical And Computer Engineering

In the event of a large-scale natural disaster, families and nations are often unprepared for post-disaster living conditions. Disaster relief shelters are inadequate replacements for destroyed homes; the crowded living space stimulates the spread of illnesses and the lack of electricity exacerbates psychological stress. A modernized shelter equipped with electricity and structural integrity would address several issues imposed by current disaster relief shelter. Using micro-energy harvesting techniques, a SmartShelter has the ability to locally generate minimal amounts of electricity and provide adequate protection for natural disaster victims. Through its novel design, the SmartShelter utilizes solar, thermal, piezoelectric, and radiofrequency energy harvesting modules to convert freely available environmental energy into a sustainable form of electricity. To reduce cost, the energy harvesting modules will be optimized for structural integrity. The energy harvesting modules will be strategically placed within the structural roof, wall, and floor of the shelter in order to maximize the amount of energy harvested and minimize material costs. As a proof-of-concept design, a prototype SmartShelter has been designed using commercially available energy harvesting modules. With this prototype, we aimed to test the

power output of the sustainable power system and verify that sufficient amounts of power may be generated. Due to hardware and software implementation constraints, we were unable to provide conclusive results of the prototype system. However, preliminary results promised desirable results once the issues were fixed. Future expansion of the proof-of-concept design will feature higher, more stable amounts of electrical power output. As the project progresses, highly customized energy harvesting modules will be designed to further reduce the cost of the overall system and maximize energy harvesting in this context. The final product will be sustainable SmartShelter that provides a constant supply of minimal amounts of power through a structural stable design which brings much needed comfort and safety to natural disaster victim.

ACKNOWLEDGEMENTS

I would like to thank Dr. Edgar Sanchez-Sinencio for directing us throughout the course of this project. We would also like to thank doctorate student Salvador Carreon, and the other graduate students in the Analog and Mixed Signals lab, for answering all our questions and guiding us towards productive solutions.

None of this would be possible without the funding support from the Undergraduate Research Scholars Program, the Research Experience for Undergraduates, and the Louis Stokes Alliance for Minority Participation – Undergraduate Research Program.

NOMENCLATURE

EH	energy harvesting
kW	kilo-watts ($1W = 1 \text{ kg}\cdot\text{m}^2/\text{s}^3$)
kV	kilo-volts
mA	milli-amperes
mV	milli-volts
RF	radio frequency

CHAPTER I

INTRODUCTION OF ENERGY HARVESTING SYSTEMS

One of the deadliest and strongest hurricanes in history was Typhoon Haiyan, which struck the Philippines in November 2013 and has resulted in 6, 268 confirmed deaths four months later [1]. Over 80% of the deaths related to this disaster occurred in the aftermath and was largely due to inadequate shelter conditions and lack of electricity [1]. The Filipino government was unprepared with adequate disaster relief shelters for the 4.1 million displaced citizens [1]. Consequently, the harsh weather conditions which followed the typhoon's landfall caused several disaster victims to contract pneumonia and other deadly diseases [2]. Inadequate shelter protection prompted the rapid spread of disease, and long-term blackouts exacerbated problems as disaster victims did not have proper access to medical or communication devices [2]. Although Typhoon Haiyan was inevitable, certain precarious measures could have been taken to promote communal survival and prevent large scale deaths like those that occurred in the aftermath.

Among the largest problem, inadequate shelter situations prevented disaster victims from physical and psychological recovery [2]. In the event of another deadly natural disaster, which is highly probably in all regions of the world, the same disastrous shelter situation could be faced due to the unacceptable shelter standards that are currently adopted worldwide. Several nations, including the United States, use tents as evacuation shelters because of their low cost, ease of

deployment, and simple construction [3]. The tradeoff for such convenience is that tents do not provide proper protection from weather conditions and are not designed to sustain long-term survival. Furthermore, electricity becomes a problem if the electric grid is down for long periods of time, which is often the case after natural disaster strikes a region. Disaster relief organizations and victims often rely on expensive electric generators to provide electricity; these generators are an unattractive option because they are expensive, noisy, and may potentially introduce more death hazards to disaster victims [4]. As a reference, diesel generators, which are the most popular electric generators used in disaster situations, cost anywhere from a few thousand to hundreds of thousands of USD per household unit [4]. They also produce significant amounts of noise, between 80-120 dB on average, which is enough noise to contribute to hearing loss [4]. As an additional hazard, they emit deadly carbon monoxide into the surrounding air, which has led to several post-disaster deaths [4]. Tents powered with electric generators are inadequate shelter conditions for citizens of the 21st century.

If long-term survival is to be achieved, modifications to currently adopted shelter standards must be made. As discussed in the previous paragraph, currently adopted disaster relief shelters lack two crucial resources necessary for survival and recovery: 1) structural integrity and 2) cheap access to electricity. Lack of structural integrity leads to easily destructed shelters that do not provide ample protection from wind, rain, or disease. If there is no cheap form of electricity available, a majority of disaster victims will not have access to electricity, thus they will not benefit from the safety that lighting, phones, and medical devices bring. Combined, these problems are a major cause of death in post-disaster living conditions. A modernized shelter

which addresses these two major issues could potentially save thousands of lives in future disaster situations.

A self-sustaining shelter that provides sturdy protection and ample electricity would address the major issues posed by currently adopted shelters. Although self-sustaining shelters have never been designed in the past, their design is feasible given the considerable advancement of micro-energy harvesting technology. Using passive energy harvesters and low-power battery management units, ambient energy from any regional environment may be converted to provide a constant supply of minimal amounts of electricity. Through strategic architectural design, the roof, walls, and floor of the shelter may be optimized for both energy harvesting and structural support. By taking advantage of the natural energy sources present within a shelter, cost may be minimized by exclusively designing the roof, walls, and floor of the shelter as energy harvesters, as opposed to designing the shelter's structure and energy harvesting units separately. Generating free electricity and providing a structurally stable shelter would provide much needed safety, comfort, and relief to families affected by a disaster.

Energy Harvesting

Energy harvesting (or energy harnessing) is the act of catching readily available energy from the environment and converting it to useful electrical energy. This conversion of energy is made possible through the conservation of energy theorem, which states “energy cannot be created nor destroyed, but only transferred from one form to another” [5]. There are abundant forms of free

energy in our environment which are essentially wasted because these natural forms of energy are not completely consumed by the physical world. Examples of freely available environmental energy include:

- Hydropower: Energy from moving water
- Wind Energy: Energy from wind power
- Solar Energy: Energy from the Sun's light rays
- Kinetic Energy: Energy from vibrational sources
- Thermal Energy: Energy from temperature differences in materials
- Radio-frequency (RF) Energy: Energy from ambient RF waves

Recent technological breakthroughs have enabled the efficient conversion of these free forms of energy into electrical power [4]. Each energy harvesting source uses specialized technology to convert ambient energy into electrical power with the highest efficiency possible. Some sources have the ability to harness large amounts of electrical power (in the kW or MW range), known as macro-energy harvesting, while some sources only have the ability to harness small amounts of electrical power (in the uW or mW range), known as micro-energy harvesting. Macro-energy harvesting systems are advantageous because they generate large amounts of power; however, they require large, heavy, and often expensive equipment to handle the large voltages. They also require external connections to the power grid to sustain operations. In contrast, micro-energy harvesting systems require small, lightweight, relatively inexpensive equipment to harness small amounts of power. An especially attractive feature of these systems is that they require no connections to the electric grid; their small footprint design allows them to serve as standalone,

self-sustaining systems, which is ideal for self-powered applications. The energy harvesting sources outlined above are categorized into their respective energy harvesting group in Table 1.

Table 1: Energy Harvesting Power

Energy Type	Energy Source	Nominal Power Generated
Macro- Energy Harvesting	Solar - Industry Grade	7.4 kW/cm ²
	Wind	7.5 kW/cm ²
	Hydropower	10 kW/cm ²
Micro-Energy Harvesting	Solar- Small Scale	10 mW/cm ²
	Kinetic	10 uW/cm ²
	Thermal	5 mW/cm ²
	Radio Frequency	0.1 uW/cm ²

*Solar has capability to fall under both energy types depending on panel size

Design of a self-starting, self-powering power system is feasible using modern micro-energy harvesting techniques [4]. Despite their ability to harness only minimal amounts of power, micro-energy harvesting systems are designed to be autonomous and independent of any external control, which is ideal for a sustainable power system.

In previous decades, self-sustaining power systems were infeasible due to technological constraints. In order for an energy harvesting system to work, the amount of power generated has to be much greater than the amount of power consumed by the management system (outlined below in Figure 1). Previously, technology was constrained on both the power conversion side and the power management side. On the power conversion side, existing energy harvesting modules often required expensive electrical components to operate, and they also lacked high

conversion efficiencies. Large amounts of power were unable to be extracted from energy harvesting due to the low conversion efficiency. On the power management side, existing power management devices required large amounts of power to operate. A large percentage of the generated electrical energy would be consumed by the management system, thus energy harvesting systems were only able to output very low amounts of power, which is undesirable for most power system.

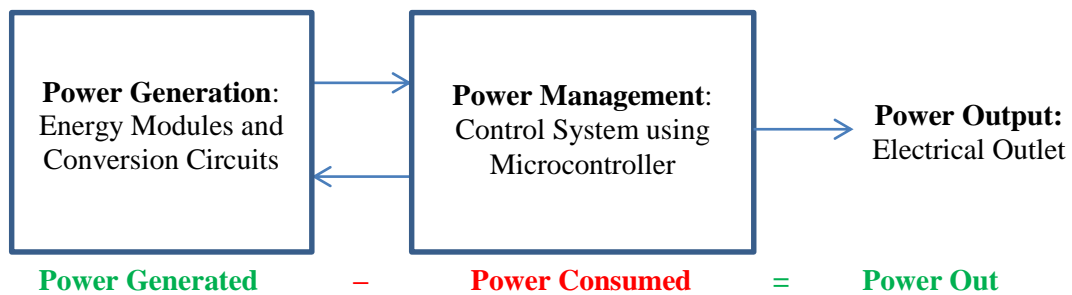

Figure 1: Power Output of an Energy Harvesting System

In order to overcome the previous barriers posed by energy harvesting systems, novel technologies will be utilized to increase the power output of the system. The final design of the SmartShelter will feature highly customized, low-cost modules that effectively convert environmental energy into electrical energy with high power efficiencies. To produce the most power output, a diverse set of energy harvesting sources will be utilized. As was presented in Table 1, the micro-energy harvesting sources which provide sufficient power include solar, thermal, kinetic, and RF energy sources. When these sources are combined, enough energy will be collected to provide a constant, low supply of electricity to a shelter. The manner in which

each energy harvesting source provides electrical power is described in the following subsections.

Solar Energy Harvesting

Solar energy is available in almost all parts of the world. Moreover, it is free and abundant in many locations. The power of the sun received on the earth surface is approximately 1.8×10^{11} MW [12]. This is significantly higher than commercial energy sources currently available. Even though it is not very efficient (usually $\leq 20\%$), it is very scalable. Therefore, it is widely utilized in both macro and micro power generation.

Any solar powered system consists of the few main components: external surroundings, solar collector or panel (consists of an array of solar cells), energy storage and the load system. The solar energy from the environment is collected by the solar collector, converted to electrical energy and is then made available to the load. The energy bank which is distributed to the load is used as a buffer to vary energy income. However, the way these modules are implemented and how they are connected can vary tremendously and is usually dependent on the application such as load demands, location, time-span and so forth.

For macro power generation purposes, large solar panels have made photovoltaic harvesting a well characterized technology. Approximately 1 mW of average power can be harvested from a 100-mm of photovoltaic cell [13]. Typical efficiency is roughly 10 percent and the capacity

factor of photovoltaic sources (the ratio of average power produced to power that would be produced if the sun was always shining) is about 15 to 20 percent [13].

For micro power generation purposes, a technique called maximum power point tracking (MPPT) is used to extract maximum available power from a solar cell. Maximum power point tracking is at the heart of solar energy harvesting. MPPT operates by taking DC input from PV or solar module, changing it to AC and converting it back to a different DC voltage and current to exactly match the PV module to the battery.

Maximum power point is the voltage at which photovoltaic module can produce maximum power (MPP) and the main aim of the MPPT is to make the solar cell operate at MPP (most efficient voltage). The challenge is that MPP varies with solar radiation, ambient temperature and solar cell temperature. Figure 2 depicts an I-V curve in a solar cell. A line intersects the knee of the curves. That line is called the maximum power point (MPP) line. At MPP, slope of the MPP line is equal and opposite to the I/V ratio and $dP/dV = 0$, where dP/dV is the change in power with respect to voltage of the solar cell [14].

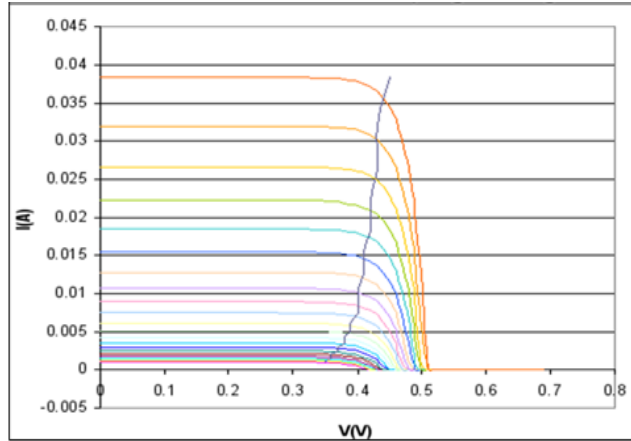

Figure 2: I-V curve solar cell

The resistance at $MPP = V/I$ and is called the load resistance or characteristic resistance of the solar cell. It draws the maximum power from device. The following equation can be used to estimate the maximum power that a solar cell can provide at optimal load:

$$P = FF * V_{oc} * I_{sc} \quad [2]$$

In this equation, FF is defined as the fill factor or the non-electric behavior of the solar cell, V_{oc} is the open-circuit voltage of the solar cell and I_{sc} is the short circuit voltage of the solar cell.

Thermal Energy Harvesting

Temperature differences exist everywhere in both natural as well as man-made environment. Air conditioning set the indoor temperatures to suit personal preferences while we dress warmly to reduce the body heat lost on a cold night. But this undesirable temperature gradient can be put to use. Heat energy in the form of temperature differences has been employed on a macro scale in industrial and automotive settings to extract electrical power from heat exhaust [7, 8]. In these

systems, the presence of large temperature differences near the exhausts presents a suitable medium to harvest hundreds of watts of electrical power. In spacecraft, radioisotope thermoelectric generators have been used to power electronic systems [9]. In such a situation, nuclear reaction of the isotopes is used to generate heat energy which is then converted into electrical energy. But as far as micro-scale portable electronics are concerned, even heat generated by human body can be harvested as energy to power them. Studies have shown that harvesting thermal energy through thermoelectric means can supply hundreds of μW of power [10, 6].

A thermoelectric device is a junction formed from two different conducting materials, one containing excess of positive charge carriers or holes and the other negative charge carriers or electrons. At the heart of thermoelectric effect is the fact that temperature gradient between the two dissimilar conductors result in the diffusion of charge carriers. The flow of charge carriers in turn creates a voltage difference. This voltage difference leading to the production of an electric current in a thermoelectric device is thermoelectric effect. It is popularly known as “Seebeck Effect” after Thomas Johann Seebeck, who is credited with discovering this technique [11].

This discovery is the basis of thermoelectric devices and is quantified by a property called Seebeck coefficient. In addition to the Seebeck coefficient, thermal conductivity and electrical resistivity are two other properties important for the optimization of thermoelectric devices. An ideal thermoelectric material has a high Seebeck coefficient, low electrical resistivity and low

thermal conductivity. Semiconductors have been found to provide the best combination of all these three properties.

The properties of semiconducting materials can change dramatically with temperature; hence they can function as thermoelectric materials within a specific temperature range that varies depending upon the material. The most commonly used semiconductor, Bismuth Telluride (Bi_2Te_3), reaches its peak performance around 70°C and has an effective operating temperature range of -100 to 200 degree Celsius [11]. Lead Telluride (PbTe), the next most commonly used material, is typically used for power generation but it is not as efficient as Bi_2Te_3 . PbTe reaches its peak performance at 350°C and has an effective range of 200°C to 500°C . Silicon Germanium (SiGe) is another semiconductor but it is rarely used as a thermoelectric material and is viable for power generation at very high temperatures [11].

A typical thermoelectric generator typically consists of multiple n and p type thermoelectric legs sandwiched between two high thermoelectric substrates. A thermoelectric generator can be modelled electrically as a voltage source in series with a resistance as shown in Figure 3. The open circuit voltage V_T is proportional to the temperature difference and is defined as

$$(V_T = S\Delta T) \quad [1]$$

where S is the Seebeck coefficient of the thermoelectric device and ΔT is the temperature difference of the generator.

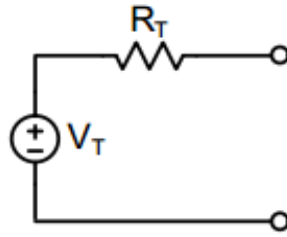

Figure 3: Electrical equivalent of thermoelectric generator

Kinetic Energy Harvesting

Our kinetic energy will be harvested via piezoelectricity. Piezoelectricity is the charge that accumulates in certain materials when mechanical stresses are applied; in the form of either vibrations, or deformations. This effect was first discovered by French physicists Jacques and Pierre Curie in 1880 [15]. For the next few decades Piezoelectricity was mostly viewed as a curiosity, culminating in 1910 with Woldemar Voigt's Textbook on Crystal Physics described the 20 natural crystal classes capable of piezoelectricity, as well as defined the piezoelectric constants using tensor analysis [16].

The first practical application of this technology was sonar, first developed in World War I. In France, Paul Langevin and his team developed an ultrasonic submarine detector with a transducer, made of thin quartz crystals between two steel plates, and a hydrophone [17].

During World War II groups in the United States, Japan and Russia discovered a new class of materials, called ferroelectrics, which had much higher piezoelectric constants than natural materials.

For the most part piezoelectric components are generally utilized in ultra-low power sensor networks, medical and remote applications [18]. Our team plans to use piezoelectricity as a much broader source of power than these previous applications. Instead of using piezoelectricity for a specific purpose, such as activating a sensor when motion in the transducer causes a power output, we plan to use it in order to collect and store power for whatever applications the residents of our shelter deem necessary.

Once our transducer has produced an AC signal has been generated it will be fed into a piezoelectric power management unit. This is a commercially available unit designed to take the transducers AC output, and convert it to a DC output, which is then used to help provide electricity to the residents of the shelter.

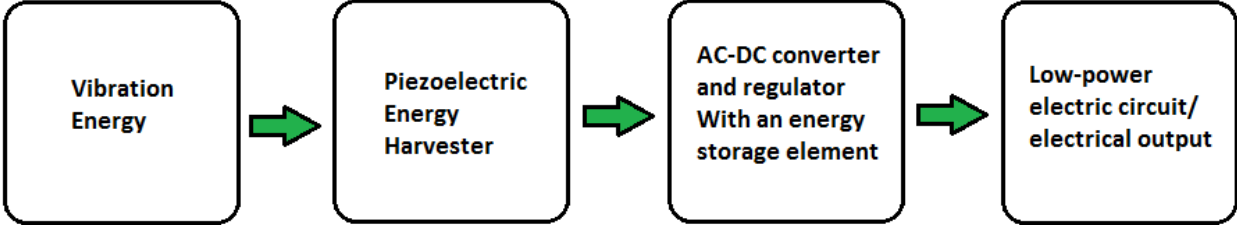

Figure 4: Kinetic Energy Harvesting Process

In order to harness the motion of residents walking across the floor of our shelter we needed to design a special floor. In order to have the floor designed and fabricated we teamed up with some members of the architecture department. After discussing the needs of our project we came up with:

Once we had our floor designed, the next step was to install the transducers in the floor so that we could begin harvesting energy. We placed the transducers in groups of 20 and wired them together in order to get 10 times more available power than would be available from a single transducer. We placed them in the floor because this is where the most vibrational energy can be harvested within a shelter.

After the transducers are wired together, their harvested energy needs to be converted into a useful DC voltage so that it may be stored on a capacitor. In order to do this, the transducers are connected to an LTC3588 Piezoelectric Energy Harvesting Power Supply. This unit takes in the transducer's AC signal and converts it to a DC signal at a user-defined level. The internal circuitry of the LTC3588 is shown below.

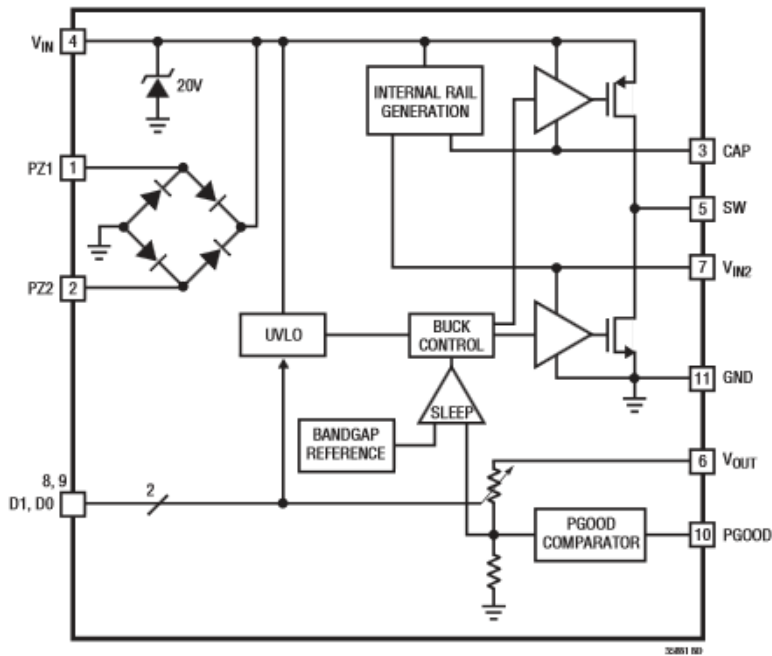

Figure 5: Internal Circuitry of LTC3588

The PZ1 & PZ2 are where the transducer connects to the power management unit. That input is then rectified by an equivalent of the four diode bridge illustrated above. From there the voltage does multiple things; firstly it charges the capacitor connected to V_{in} , secondly it is used to set the internal rails, and finally it powers the internal amplifiers while outputting to the SW output. The D1, D0 pins are used to set the output voltage, as well as the quiescent current according to the table below.

Table 2: Expected Power Operations

Table 1. Output Voltage Selection

D1	D0	V_{out}	V_{out} QUIESCENT CURRENT (I_{vout})
0	0	1.8V	44nA
0	1	2.5V	62nA
1	0	3.3V	81nA
1	1	3.6V	89nA

The PGOOD pin may be connected to a controller in order to put the circuit to sleep. This will not be used in our initial modules, but when the microcontroller set up and connected to the final module, the PGOOD will be connected to the microcontroller, so that it may be shut down whenever it isn't healthily harvesting. This will allow us to save power, and in the condition of any malfunction that causes the kinetic module to drain power, it can be put to sleep to prevent power loss.

Like every other power source, the output energy of the kinetic stage will be stored in a capacitor before being transferred to our output storage device, and finally it will be used from there to power the shelter; excepting the small portion of it needed to power the microprocessor and the transmitter.

Rf Energy Harvesting

The history of harvesting RF energy goes back all the way to the end of the 19th century, with Nikola Tesla's experiment with transmitting power using his magnifying transmitter; the long term goal of which was worldwide wireless power distribution [1]. In Colorado Springs, CO, USA he carried out power transmission experiments via the electric field and capacitive coupling, paired with experiments reminiscent of transmission line and waveguide effects, but in a wireless system [2], [3]. Tesla's final experiment involving wireless broadcasting, communications, and power transmission; but it never came to fruition due to issues with funding [4].

Wireless power was then abandoned by the world, until after World War II, when high power vacuum tubes capable of operation at microwave frequencies made the long range transmission of power possible [5]. The first wireless microwave power transmission system was demonstrated by William C. Brown, at Raytheon, in 1963 [6].

Wireless power transmission systems can generally be divided into far-field and near-field transmission. As the name suggest far-field involves the transmission of wireless power over vast

distances. Due to the losses associated with beaming energy large distances far field schemes are, for the most part, only viable in certain systems, for example low-power sensor networks, where efficiency is not a huge concern and your system could be powered with a microwave beam that does not break any microwave safety standards. Far-field transmission could also be useful in high-power systems (such as space, military, or industrial applications) where being able to receive wireless power more than offsets the costs of the system and wireless losses. [5] For devices with a more moderate power requirement it makes more sense to use a near-field transmission system at a frequency lower than 100 MHz for efficiency, and regulatory reasons.

With our project we are aiming to harvest energy already in the air, and not transmit energy to our shelters. Since the goal is to harvest ambient energy, as there will be no power to transmit in a post disaster area, it doesn't make sense for us to base our design on these more traditional RF power paradigms. In order for the maximum amount of power to be gathered it makes the most sense to focus our design around the frequencies that have the heaviest usage, as they will yield the greatest amount of power. For this reason, as well as commercial part availability, and our projects purpose, the initial design was focused in the ISM band.

The ISM band describes the industrial, scientific and medical radio bands. These frequencies are reserved for industrial, scientific, and medical purposes other than telecommunications. More specifically our frequency range is the 902-928 MHz range, due to the fact that the power management chip as well as the transmitter used in testing are made to work for this band.

The power management chip used is the Powercast P2110 – 915 MHz RF Powerharvester Receiver, and it will initially be paired with the TX91501 – 915 MHz Powercaster Transmitter.

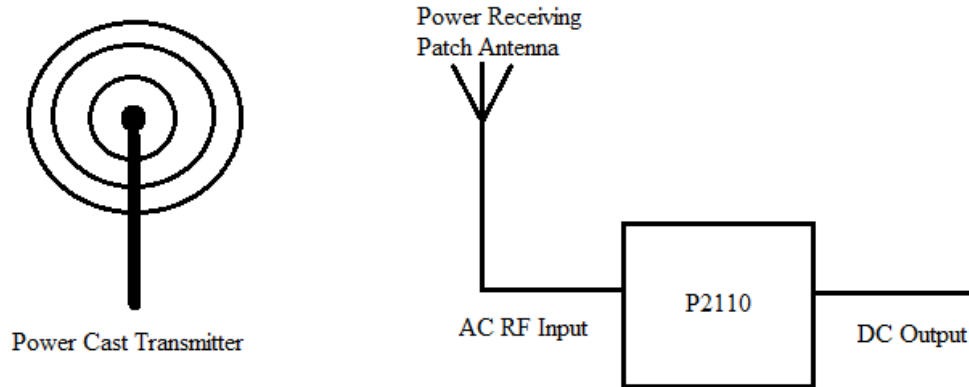

Figure 6: RF Energy Harvesting Design

The ideal is that the transmitter will beam power towards a patch antenna that was designed in order to pick up signals at 915 MHz. The antenna will be connected to the P2110, and the signal will go from the antenna to the chip. The chip then converts it from AC-DC and steps it up to the output voltage that the whole system will be using.

The transmitter was a commercially available piece that was purchased, and took no design on our part. This transmitter has a 3 watt maximum power output, and requires a 5V DC supply to operate. The signal is vertically polarized (with the logo in an upright position) [7]

Note that the polarization of an antenna/wireless transmitter refers to the orientation of its electric field with respect to the surface of the earth, and is determined by its physical structure as well as its position.

Due to the team's modest antenna design experience, the decision was made that the initial antenna design should be a patch antenna. Patch antennas are a very simplistic antenna type that consists of a rectangular sheet or "patch" of metal, mounted over a larger sheet of metal, which acts as the ground plane.

The P2110 is a commercially available part that takes the power that is collected by the antenna and turns it into a DC voltage that is then used for to power our system.

CHAPTER II

POWER SYSTEM DESIGN & SIMULATED RESULTS

To prove feasibility of a sustainable micro-energy harvesting power system, a proof-of-concept prototype of the SmartShelter power system will be designed. This prototype will prove that solar, thermal, piezoelectric, and radio-frequency energy sources are sufficient to provide watts of power to externally connected devices. Furthermore, using a low-power power management unit, the prototype will prove that a constant output of DC power is achievable without the support of backup generating units. The prototype design will utilize commercially available modules as proof-of-concept. Future expansion will replace these commercial modules with highly customized and inexpensive modules designed to suit the SmartShelter's sustainable power system.

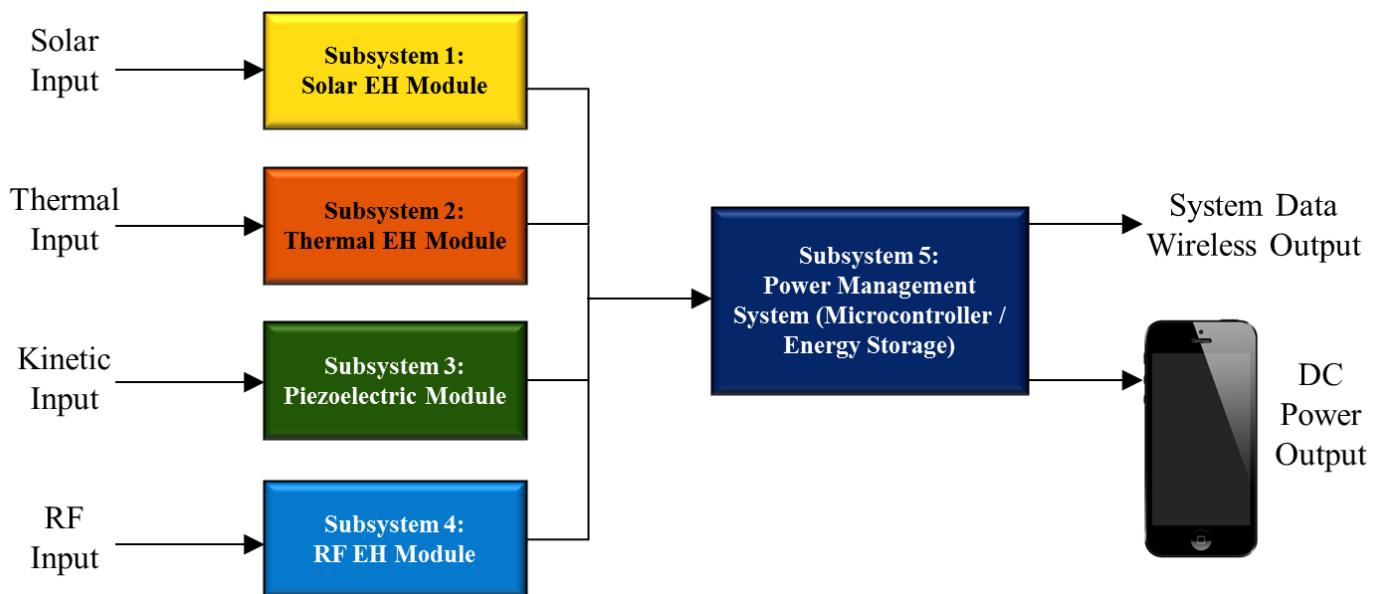

Figure 7: Modular Overview of SmartShelter's Electrical Power System:

A modular overview of the SmartShelter power system is shown in Figure 7. The SmartShelter will have 5 subsystems, 4 of which provide energy generation, and 1 of which provide power management. Subsystems 1-4 consist of the solar, thermal, piezoelectric, and radio-frequency energy harvesting modules. Subsystem 5 consists of the low-power microcontroller and low-power boost converter which provides battery management/energy storage.

In order to implement the above system, each subsystem must be designed and independently tested. Each generating module (subsystems 1 – 4) will have a commercial energy harvesting module, which harnesses AC energy from the energy source, and a peripheral circuit to boost and convert it into DC energy. Each subsystem circuit will be designed independently of the others to ensure the safety, reliability, and efficiency of each subsystem and improve the overall stability of the entire system.

The design process of each energy harvesting module (subsystem 1 – 4) will be the same. The process is described below:

- Design Step 1) Design /simulate circuit using circuit simulation software
- Design Step 2) Implement circuit on Printed Circuit Board (PCB)
- Design Step 3) Test Circuit and compare actual /simulated results

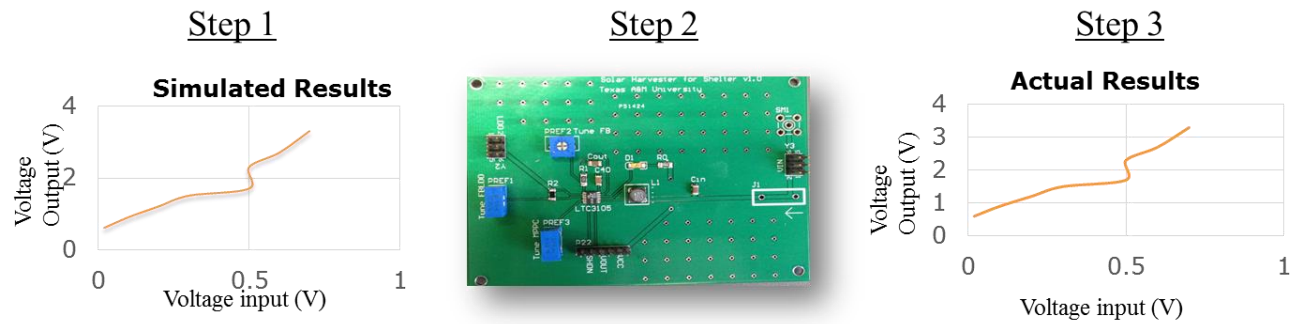

Figure 8: Design Process of Each Energy Harvesting Module (subsystem 1 – 4)

Subsystem 5 will also utilize commercially available microcontrollers and energy storage devices. The microcontroller will be optimized for low power consumption, and the battery management unit will be optimized for low power sensitivity and storage. This subsystem will be directly connected to the other subsystem circuits, thus no circuit for subsystem 5 will be required for the prototype design.

After each subsystem is complete, the subsystems will be connected and optimized to form the final circuit of the SmartShelter’s electrical power system.

Subsystem 1: Solar Module Design

After studying the proven concepts of thermal energy harvesting, specifications for input and output current as well as voltage were set. After setting the specifications, various commercially available integrated chips that could possibly be used for thermal and solar energy harvesting

were shortlisted .Most of the modules were selected from companies such as Texas Instrument, Linear Technology and Maxim IC.

The properties of these products were studied in detail with the help of datasheets available on the websites of companies and circuit simulations were carried out. Popular computer software called LTspice was used to simulate the preliminary circuits for thermal and solar energy harvesting. LTspice provides a variety of custom design simulation tools and devices, which allows effective evaluation of circuits. For this research LTspice IV was used, which is a powerful and high performance simulator, schematic capture and waveform viewer [1].

After validating the characteristics of integrated chips (circuits) with the help of simulations, finally the one that would best suit the needs of our research was chosen. Efficiency, cost and performance was taken into consideration while making the decision. For thermal energy harvesting, Linear Technology's LTC3108 was selected. The LTC 3108 is a highly integrated DC/DC converter ideal for harvesting and managing surplus energy from very low input voltage sources. The step-up topology operates from input voltages as low as 20mV. LTC3108 provides a complete power management solution for wireless sensing and data acquisition

Apart from the integrated chip, thermal energy harvesting required the use of thermoelectric generators or TEGs (input source), transformers and capacitors. Coil craft transformers of turn ratios 1:20, 1:50 and 1:100 were selected upon considering factors such as low startup voltage,

DC resistance and inductance of transformers. The LTC3108 is designed to present a minimum input resistance (load) in the range of 2Ω to 10Ω , depending on input voltage and transformer turns ratio. For a given turns ratio, as the input voltage drops, the input resistance increases. This feature allows the LTC3108 to optimize power transfer from sources with a few ohms of source resistance. Keeping these properties in mind, a suitable TEG was selected. Application information in the datasheet for LTC 3108 was used as a guideline to select capacitors. Depending on the desired output voltages and the turn ratios of transformers, appropriate capacitors were selected. The V_{store} capacitor was carefully selected. A large value was used to provide holdup at times when input power maybe lost. To minimize losses and capacitor charge time, low leakage capacitor was used. Ceramic capacitors and supercapacitors were used.

The following circuit was used to carry out simulations using LTC 3108 with the help of LTspice:

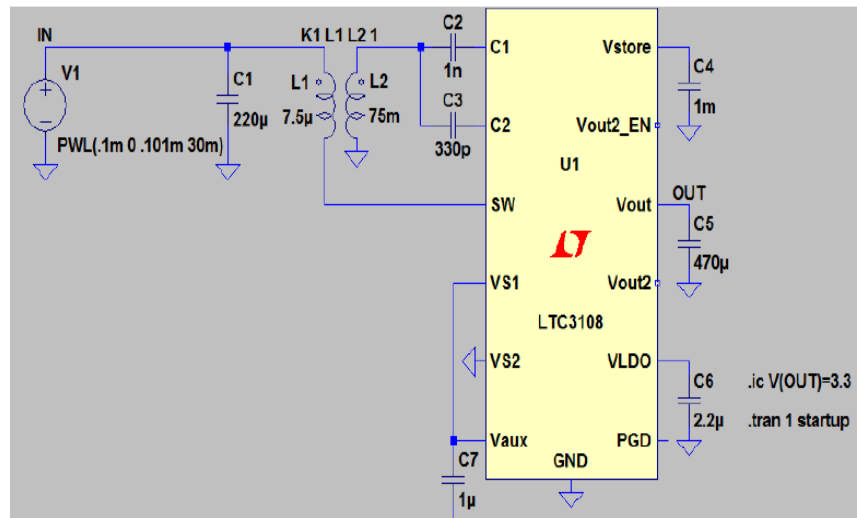
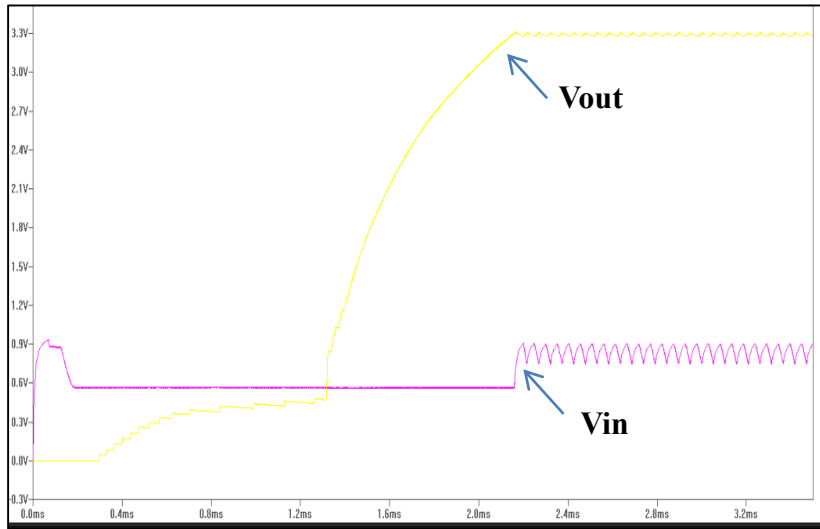

Figure 9: Circuit for Thermal Energy Harvesting

Vin & Vout Vs. Time



Vin Vs Vout

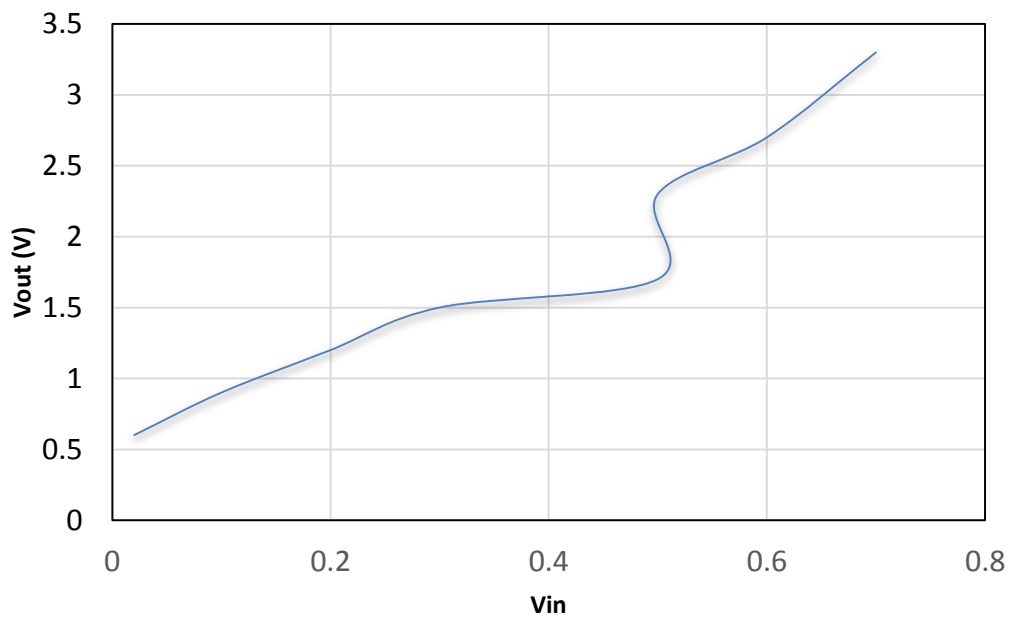

Figure 10: Simulated Results for Solar Module: Vout Vs. Vin

After the simulations, Printed Circuit Board (PCB) layouts were designed with the help of Altium Designer software. Altium is an Electronic design automation (EDA) software that helps in creating new functionality and product differentiation, in order to help build layout for electronic systems such as printed circuit boards. It provides support for embedded components. Embedding important components within the layers of a circuit structure creates faster, more reliable products that are smaller and have lower production costs [2]. The PCB layout was designed using Altium based off the guidelines on LTC 3108 datasheet. Figure 11 shows the final PCB design.

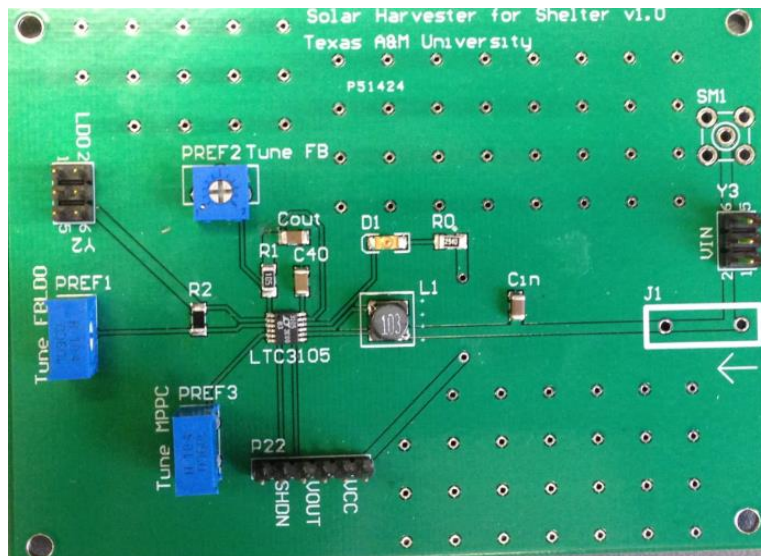

Figure 11: Printed Circuit Board

After the Printed Circuit board was manufactured, the electrical components were soldered and the board was tested. Once thorough individual testing of boards is complete, they will be combined together so that they can function as a single energy harvesting unit.

Subsystem 2: Thermal Module Design

Similarly, for solar energy harvester, linear technology's LTC 3105 was selected. The LTC 3105 is a high efficiency step-up DC/DC converter that can operate from input voltages as low as 225mV. A 250mV start-up capability and integrated maximum power point controller enable operation directly from low voltage, high impedance alternative power sources such as photovoltaic or solar cells.

Solar Energy Harvesting required the use of solar panels, capacitors and inductors in addition to integrated chips. Inductors were selected such that they had low DC resistance and sufficient saturation current time. A large inductor was chosen for this research project, since large inductors are recommended for low-voltage application purposes. Input capacitor selection was very important in this case since it is a low-voltage and high input source system. The input capacitor should be large enough to allow the converter to complete start-up mode using the energy stored in the input capacitor. But if a very large capacitor is used, it would delay the start up time. Mostly ceramic capacitors were used.

LTC 3105 was chosen over other available products due to the following properties:

- It is a step-up DC/DC converter
- Ideal for Off-grid system
- Maximum Power Point Tracking (MPPT) Control - An integrated maximum power point controller (MPPC) enables operation directly from high impedance sources, like

photovoltaic cells, preventing the input power source voltage from collapsing below the user programmable MPPC.

- Peak current limits are automatically adjusted to maximize power extraction from
- the source, while Burst Mode operation reduces quiescent current to only
- $18\mu\text{A}$, optimizing converter efficiency.
- Applications:
 - Solar Powered Battery/ Super-capacitor Chargers
 - Cell Phone, MP3, PMP and GPS Accessory Chargers

The following circuit was used to carry out simulations using LTC 3105 with the help of LTspice:

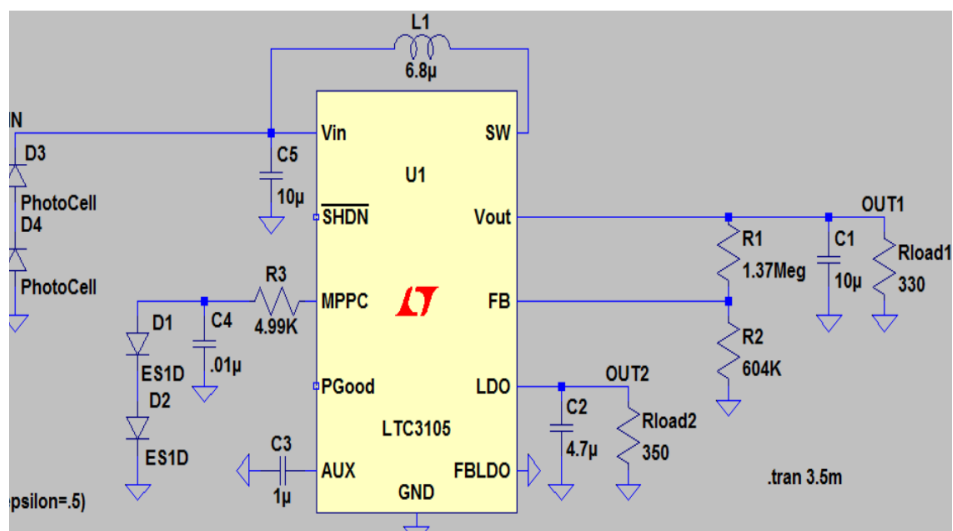

Figure 12: Circuit for Solar Energy Harvesting

The Input and Output voltage for thermal energy harvester can be seen below as simulated with the help of LTpsice.

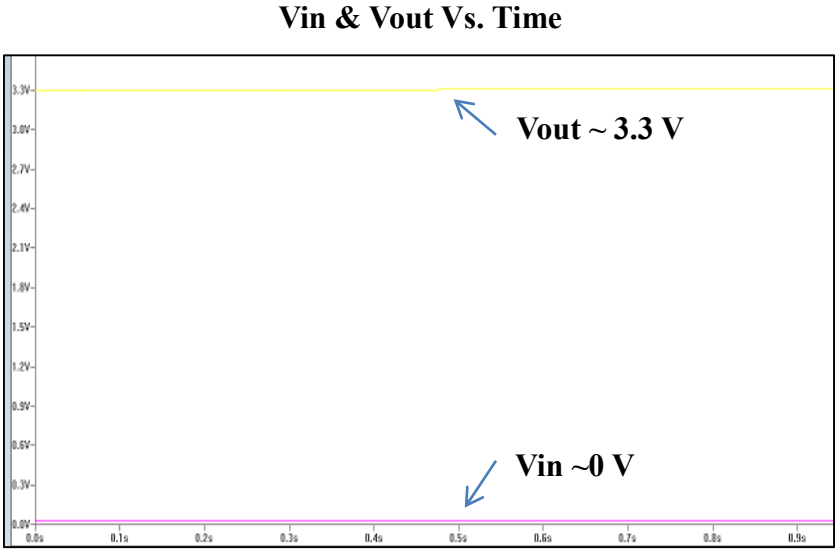

Figure 13: Simulation Results for Thermal Module

After the simulations, Printed Circuit Board (PCB) layouts were designed with the help of Altium Designer software and by closely following the PCB layout guidelines on the datasheets of LTC 3105. After the Printed Circuit boards were ready, all the electrical components were soldered and tested. Once thorough individual testing of boards is complete, they will be combined together so that they can function as a single energy harvesting unit.

Subsystem 3: Kinetic Module Design

The kinetic portion of this shelter consists of the piezoelectric transducer, the custom floor, which causes the piezoelectric transducer to vibrate and conduct electricity, the power management unit, and the Printed Circuit Board (PCB) that the management unit is a part of.

This portion requires knowledge of mechanical engineers, as well as electrical engineers. For more information on the mechanisms of the floor please refer to (what's his name?)'s thesis.

For our transducer we ordered various transducers, from a company called Mide. The transducers have an electrical output, as well as the transducer which is connected to the electrical output.

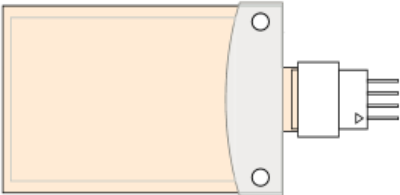

Figure 14: Transducer

The transducers conduct whenever they are deformed (by shaking) at the fundamental frequency of the piezoelectric material. The transducers are attached to the floor at the base (the side with the electrical output). This portion is held relatively stable, and the energy sent into the floor through walking, this energy is directed at the transducer, and the tip-to-tip vibration causes the deformation of the transducer, which is the source of the electrical power.

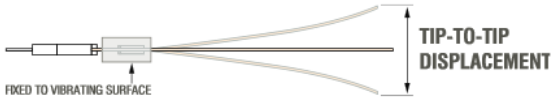

Figure 15: Transducer Displacement

The output power of the transducer can be altered a number of different ways. Having the transducer vibrate at a frequency as close to its rated frequency as possible is one of the most obvious methods. Another method, which is slightly less intuitive, is to lower the frequency below the rated value, and then add a weight to the tip of the transducer. The added energy going into the transducer in order to move this larger mass translates to a higher output of electric power. Below are a few tables put together by the company who made the transducer which map this relationship.

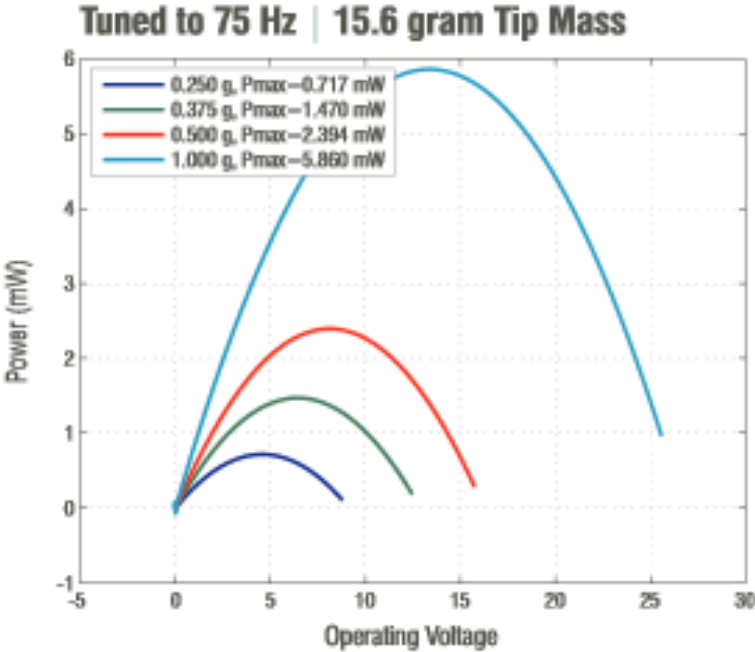

Figure 16: Operating Voltage and Power

As the tables show a mass tip on the end of this particular transducer can raise the harnessed power by as much as 300%.

The floor was designed by some members of the architecture school, and is fully explained in their thesis. The important information is that it holds the transducer base, and translates energy from walking into vibrational energy for the transducer.

The power management unit used is the LTC 3588. This unit takes the AC signal that the transducer outputs, and converts it into a DC output voltage, which is much more useful for our purposes. The needed additions are fairly minimal. Just a few capacitors and an inductor all put onto a PCB I designed. The application graphic provided by the datasheet (shown below) is what I used to design my PCB and pick my components.

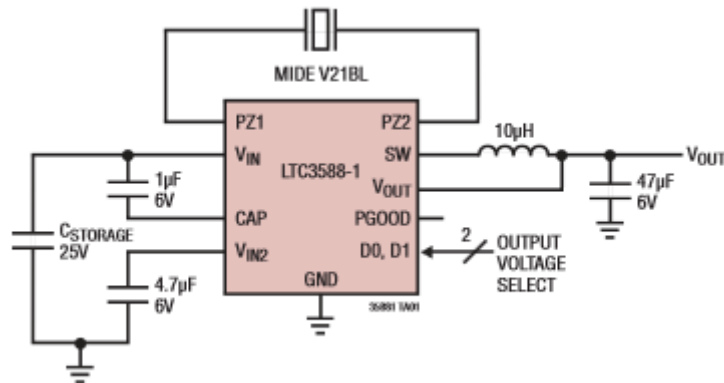

Figure 17: Example Set Up

This particular power management unit was chosen because it is designed to deal with AC voltages in the range of what our transducer will be outputting—the datasheet example even shows a Mide transformer.

The output can be set at 1.8V, 2.5V, 3.3V or 3.6V using the output voltage selection pins. This could be don't programmatically with a microcontroller, if you needed to be able to change the output, but since we only want it to stay at 3.3 volts at all times we just elected to short these pins to the 3.3V settings.

The output current can be as large as 100 mA, meaning that if our kinetic motion provides the necessary energy to power the transducer well enough the kinetic portion of the power will be a relatively large contribution to the overall system.

Once the appropriate components were selected it was time to design the PCB. This was done using our schools software which is called Altium. This software is fairly easy to use. One of the first things that needs to be considered when designing your PCB is that they cost more the larger they are; so it behooves you to make it as compact as possible. This is done by keeping components close and not wasting space needlessly.

The capacitors, inductors, and headers are all very common parts, so their shape and size is already saved inside of the Altium libraries. The LTC 3588 however, is not. This means that in

order to place the necessary pad on the PCB a footprint must first be designed. Altium has a wizard that makes this quite simple.

Once all of the separate portions are built or acquired the next step is putting them all together, and testing the combination out. This is fairly easily done. The transducer has mounts built into it, which is where it connects with the floor. The output of the transducer is then connected to the input of the power management PCB. This drives its power through the power management unit and out to a storage capacitor. In order to determine what kind of power is being generated the next step is to then run the output through various loads and taking measurements. Most importantly voltage and current measurements will be taken in order to calculate the power being output. It will also be important to take measurements controlling both the speed of those walking, and the downward force they apply with each step (taking into account their weight and how hard they are stomping).

Subsystem 4: Radio-Frequency Module Design

The next portion that needs to be designed and tested is the RF module. This is the module that will take radio waves and convert them into useable electric power. Of the various harvesting methods this method is the least commonly used, as it is new, and harvests a relatively low power.

Testing the efficacy of the radio frequency harvesting portion of the project first required a few things. Firstly an antenna was needed in order to harvest the power produced by the transmitter, secondly the power management unit, on a PCB with the necessary components, and lastly basic lab equipment to test the output of the power management unit.

The power management unit has already been briefly touched on in the introduction. It takes in an AC signal at 915 MHz and converts it to DC at the same time that it steps up the voltage. This means that the very small AC input can be turned into a voltage that is actually useable, but in order for this to be possible the current must be very small. This is due to the fact that the input AC signal is very small, and in order for power to be conserved when it is stepped up the current must be proportionally stepped down. This is why the RF portion of the shelter will be providing such a relatively small portion of the power for the shelter.

In order to harness the AC radio frequency energy output by the transmitter an antenna needed to be designed and fabricated. The decision was made between me, a grad student advisor, and another professor to build a patch antenna, whose dielectric was air. This would allow for greater efficiency, as well as lower the costs that would be associated with buying a material to use as a dielectric.

After deciding on the antenna type and make-up the next step was coming up with the dimensions of the copper patch. In order to do this the first step is to use an online calculator that gives you an estimate of your dimensions based upon ideal antenna equations; these values are your starting point. From there a more advanced RF design program is needed to take into account real world non-idealities so that more exact dimensions can be found. The program available to my team is called HFSS. With our initial estimates at patch size put into the system all that had to be done in order to find better design parameters was a sweep of dimensions, with respect to our input frequency of 915 MHz, until the program led us to the proper dimensions for a real world patch antenna (Dimensions). The next step was to sweep the location of our coaxial cable, in order to find where the cable needed to be placed in order to minimize losses (offset). The computer does a great deal of the design work, once you've built a realistic starting point to work off of.

Once these dimensions are determined all that is left to do is to fabricate the antenna. This was done using 10 gauge copper sheeting, cut to the proper dimension, as well as a drill to put a hole in the ground plane with the proper offset, for the coax cable. In order to keep the two plates separated small nylon spacers (must be 5mm tall) may be used. When dealing with an antenna of such a large size the small spacers, with a relatively low dielectric constant, will have a negligible effect.

In order to test the efficacy of the setup many methods are reasonable, but with our end goal in mind the most realistic testing approach was to hook up the output voltage to a capacitor, in order to see how long it takes to charge. Once that is understood when your antenna is an arbitrary distance from the emitter the next step is to vary the distance, in order to see how the charging time changes as the distance from the power source does. Once that is known the distance can be decided based on the energy needs of a given system.

Subsystem 5: Power Management Unit Design

In order to control the storage and flow of electricity, a power management unit is needed to manage the output of the entire system. A power management unit (PMU) typically consists of a microcontroller (MCU), which is a customized computer that is programmed to perform a specific function, and an energy storage unit, which stores the harnessed energy. The microcontroller is connected to each EH module and monitors the power output. The energy storage unit unifies the power output of each module and stores it in a single battery unit, thereby ensuring a constant supply of electricity.

A critical element of the PMU design is the power consumption. As outlined in figure 1, subsystems 1-4 generate energy, while subsystem 5 is the only component of the entire system that consumes power. In the past, a standalone energy harvesting power system was unfeasible because the previous generations of PMUs required more energy than could be generated through EH modules. Using modern versions of low-cost low-power PMUs, subsystem 5 may be

designed to consume only a small percentage of the actual harnessed power. The design will be optimized to reduce this percentage of system power consumption and maximize power output.

The main component of the PMU which will consume power is the microcontroller. The MCU must perform the following tasks to optimize the power generation and power output: 1) monitoring the health and voltage output of each of the modules, 2) control which modules are to be used at a given instance based on current power generation values, and 3) wirelessly transmitting these results to the offsite management unit, which logs the data of the entire system. Analog voltage readings will be taken from each module using the MCU's analog to digital converter (ADC) embedded unit. Using these voltage readings, the MCU will decide should be used at a given instance. If certain EH modules are not generating enough power, they will be unattached from the system using a switch in order to reduce load. For example, when there is not sunlight available, the solar module will be switched off so that it will not attempt to consume any of the generated power. Similarly, when there are no people walking inside the home, the piezoelectric module will be switched off in order to reduce the load of the battery storage unit.

The battery storage unit must be optimized for power storage capacity. The main function of the battery storage unit is to store all of the harnessed energy, ideally with 100% efficiency and zero power losses, in order to provide a constant supply of electricity. The battery storage unit functions like a DC battery; whenever a device is attached to the terminals, it will provide

electricity to power the unit. When no devices are attached to the battery, the power will be stored for later use. The battery storage unit will harness all of the generated energy and unify it in a single battery unit. Because of the diversification of energy sources, the battery storage unit is expected to provide a constant supply of electricity.

The hardware selected for the control circuit must be optimized for low levels of power consumption. The hardware components in this system are crucial to the entire system because they are the main power consumers. Subsystems 1-4, the EH modules, generate power, and therefore are the power generators. However subsystem 5, the control circuit, consumes power because of the several control operations it must perform. Hence, the hardware must be critically analyzed to reduce the amount of power consumption.

The hardware consists of: the microcontroller, analog voltage switches, and electrical switches. In the search for energy efficient components, Texas Instruments stood out as the leading producer of ultra-low power energy harvesting components. Texas Instruments (TI) has a wide selection of ultra-low power microcontrollers as well as battery management modules. Among the line of TI's ultra-low power microcontrollers, the CC430 was selected because of its wireless networking capabilities. As quoted from their datasheet, the CC430 is the lowest power microcontroller that can transmit and receive wireless information in an efficient manner.

Using TI's CC430 microcontroller, the system will be able to establish communication with a remote computer and will also be able to efficiently control the circuit. The main program will run a control algorithm that uses the voltage readings from each of the EH modules to control the power output. The flowchart shown in Figure 18 highlights the pseudocode for the main program running on the CC430 MCU. The program is implemented such that low power modes are efficiently utilized and interrupts enabled consuming minimal power.

Figure 18: Flowchart Highlighting Psuedocode of Algorithm

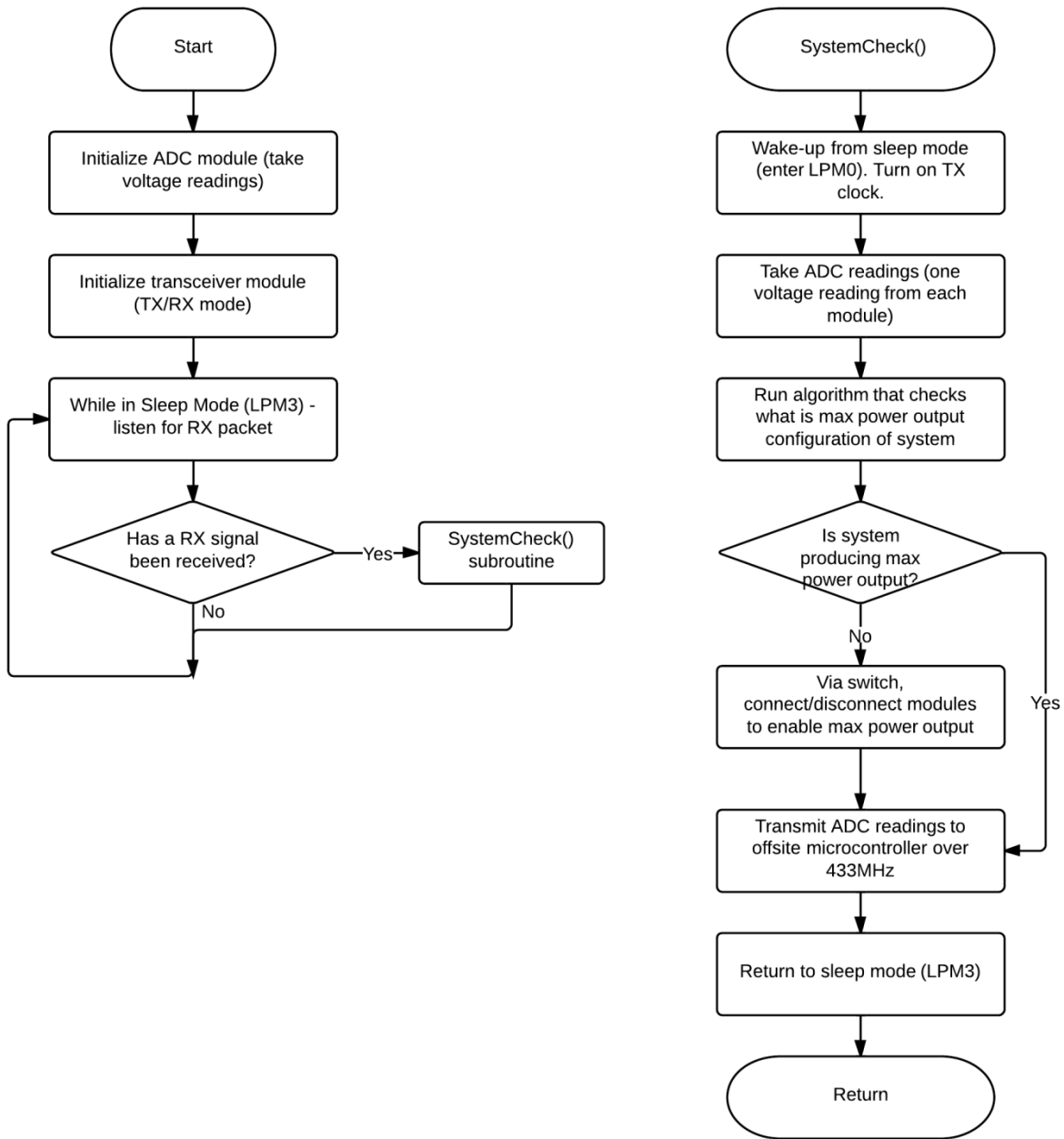

CHAPTER III

ACTUAL POWER SYSTEM RESULTS & COMPARISON

Each subsystem circuit was tested independently to ensure proper functionality. The measure results were compared to the simulated results of the previous chapter. Some subsystems experienced more difficulties than others due to hardware constraints. An analytical explanation of each subsystem's results is described below.

Subsystem 1: Solar Module Results & Comparison

A lamp with 40 Watt bulb was used a source of light instead of solar energy. We noticed that as the intensity of light increased on the solar cells, the output voltage increased and then finally peaked off at about 3 V. The following table describes the result in detail:

V_{in} (V)	V_{out} (V)
0.25	1.27
0.3	1.56
0.35	1.9
0.4	2.3
0.5	2.5
0.6	2.99

Table 3: Output Vs. Input Voltage

The efficiency of the system is well-defined in the graph below:

- Efficiency is defined as :
 - $\text{Efficiency \%} = (\text{Output Power} / \text{Input Power}) * 100 \%$

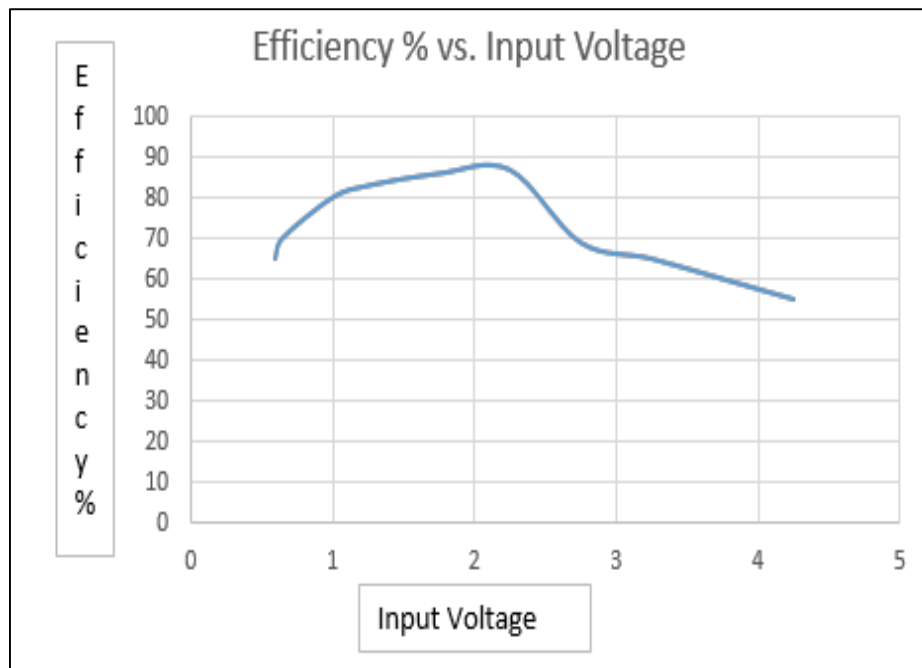

Figure 19: Efficiency % vs. Input Voltage

The simulated results very closely follow the actual results for solar energy harvester. For the LTSpice simulation, as we increased the input voltage from 0 to 0.8 V, the output voltage increased from 0 to 3.5 V. When we carried out the actual experiment with the Printed Circuit Board, as we increased the input voltage from 0 to 0.6 V, the output voltage increased from 0 to

3 V. Also, we expected a power output of about 1mW from the solar cells that are being used for testing purposes, and we got a power output of about 0.9mW which is very close to the expected result.

Subsystem 2: Thermal Module Results & Comparison

The design for thermal did not work as expected. We got very low output voltage compared to what we expected according to preliminary results which were obtained using LTspice. The actual problem could not be figured out. But we made few conclusions based on observations and measurements. They are described as follows:

- We might have fried the chip (LTC 3105) in the circuit due to overflow of current.
- Soldering issues – We might have short-circuited one or more pins in the chip while soldering. The LTC 3105 chip is very tiny and hence requires a precision while soldering.
- Compared to our preliminary simulation using LTspice, when we actually designed the circuit using Altium, we left few pins unused since we did not need them. This could also be a reason for unexpected results.

To rectify the circuit design of the thermal energy harvester, we redesigned the schematic and layout and fabricated it again. We gain had issues as the parts used for thermal design are very small, specially the chip. Hence, the pins in the chip got short-circuited which caused the input pin to act as ground and in turn grounding many pins in the printed circuit board.

We did not expect results for thermal energy harvester as the first design failed due to reasons explained above and the second design had soldering issues, causing short circuiting.

Subsystem 3: Kinetic Module Results & Comparison

Due to the methods available to us for vibrating the transducer, the results from the kinetic module were inconclusive. We were unable to get accurate or repeatable measurements from this specific module. The problem lies in the method by which we generate vibrations to convert into electrical power.

In practice, we will embed the kinetic modules in the wooden floor of the shelter. Vibrations will be extracted from people's footsteps. It was difficult to mimic vibrations from people's footsteps with our fingers, or using any other vibration method. Using finger tapping, we were able to get some positive trends depending on how hard and fast the transducer was tapped. As one would expect, the harder and more rapidly the transducer was tapped the higher the power output. The power output ranged from 1 mW all the way up to almost 15 mW. This power is very unsteady due to the way the transducer was used, thus no decisive results have been extracted.

The actual results could not compare to the simulated results because of the non-ideal conditions in the actual test circuit. During simulations a perfect AC voltage was used, and in practice the transducers were not vibrated at their perfect frequency. In order to improve the power output,

improvements to the vibrational sources (which include the floor and finger tapping method) could be made.

Subsystem 4: Radio-Frequency Module Results & Comparison

The RF testing was done with various distances between the circuit and the transmitter and various output resistances in order to determine the output power, and how it varied depending both on distance, and the output resistance. The three distances used were 15 cm, 30 cm and 40 cm. The resistances were different depending on the distance, due to varying input powers.

Below are tables of the various output powers vs. output resistances for each distance

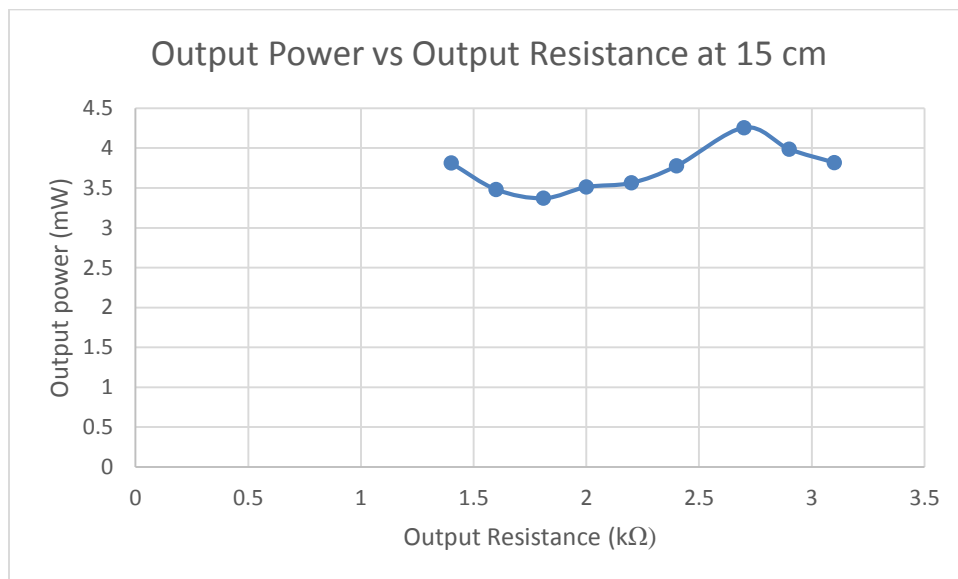

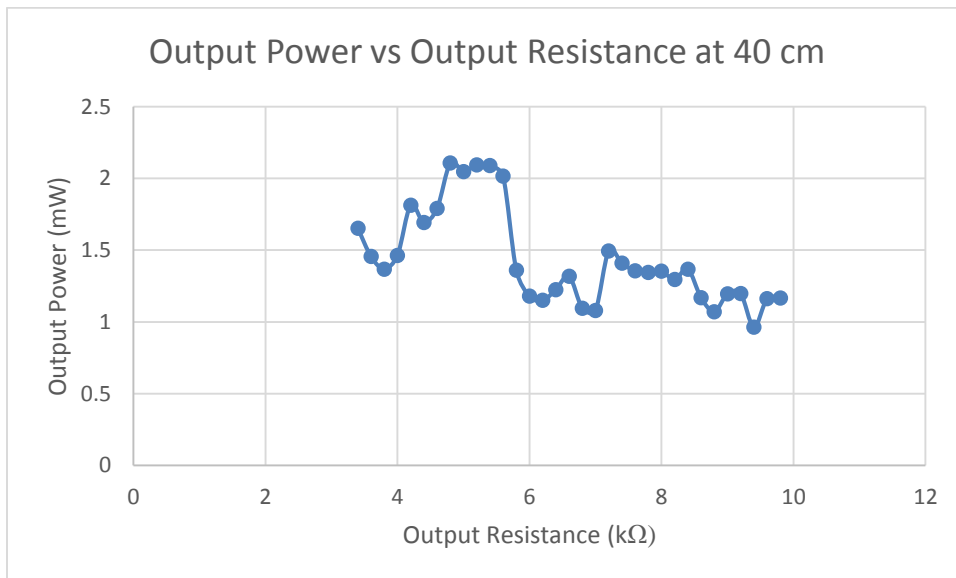
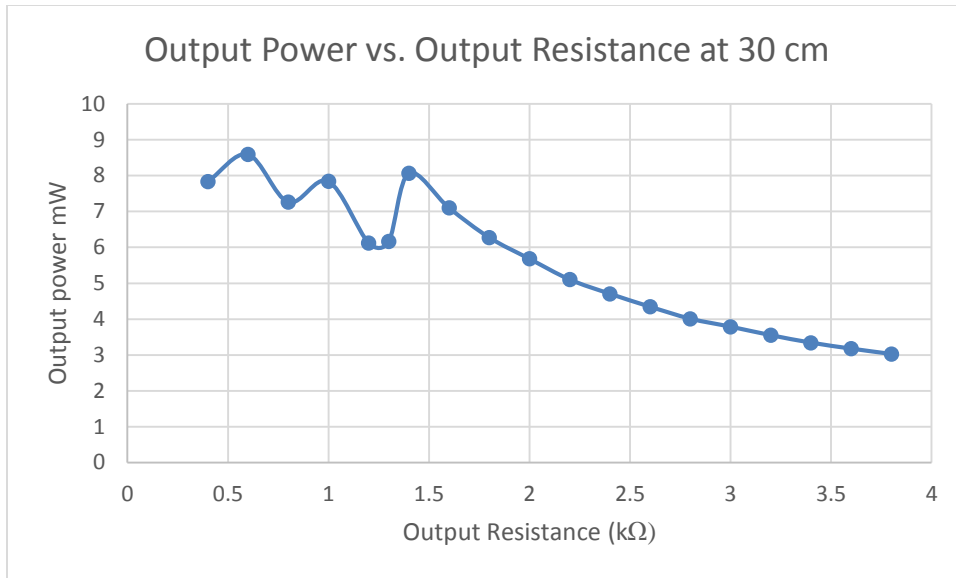
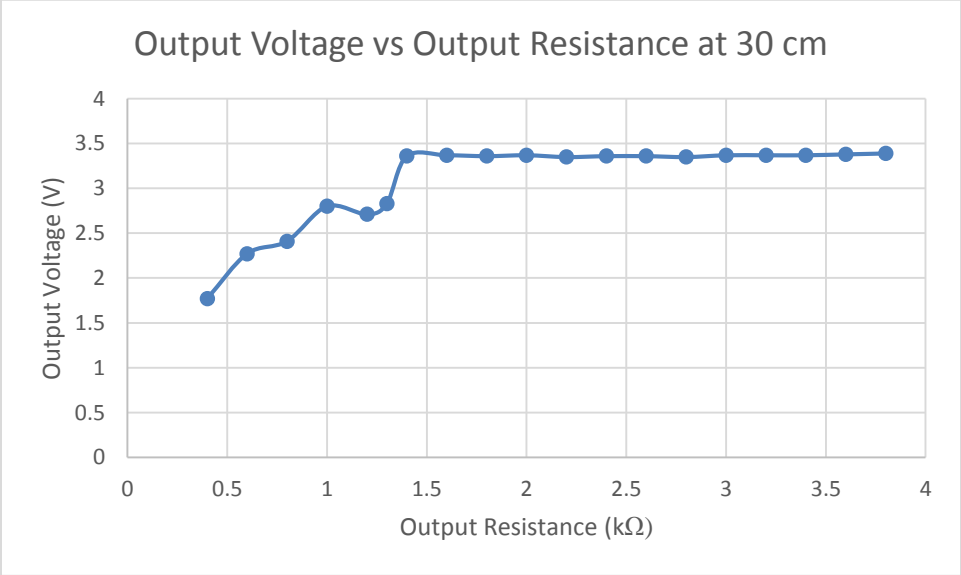
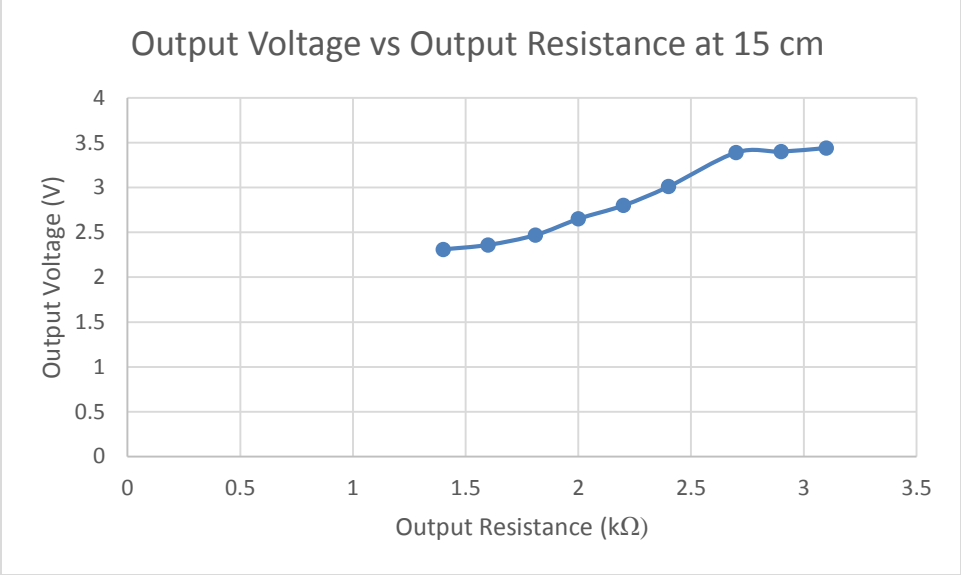
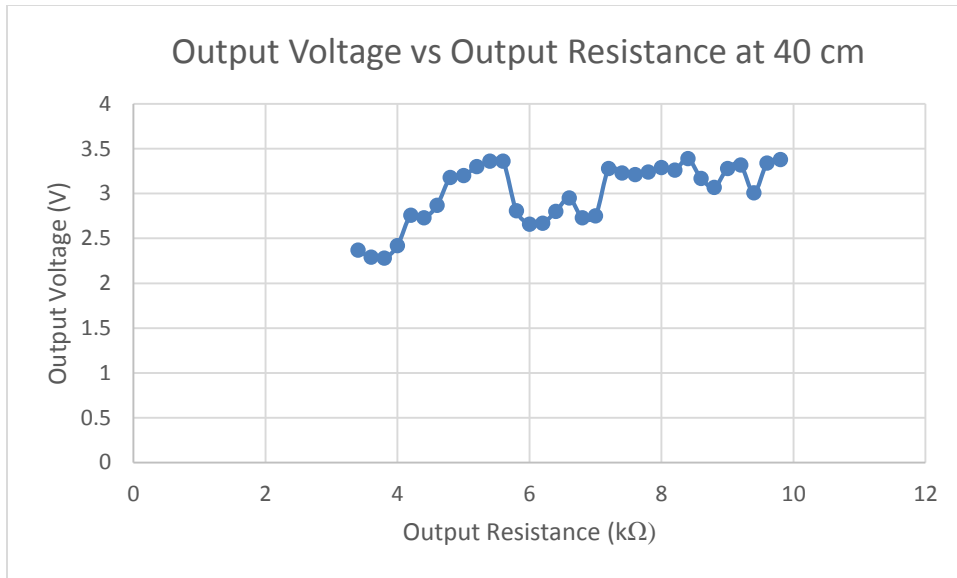

Figure 21-23: Output Power vs Output Resistance

The peak in output power at 30 cm illustrates the fact that when the transmitter and receiver are too close the antenna can't get at the proper angle for maximum power harnessing, and that once you pass the "sweet spot" around 30 cm the maximum output power drops quickly. Another important thing illustrated by the 30 cm graph is the fact that the voltage tops out, and with a

maximum voltage and increasing output resistance the output power drops with the increased resistance. This is illustrated by the fairly constant drop on the second half of the graph. The next set of graphs will show the output voltage against the output voltage. This is necessary because while many of the above graphs show a fairly constant power the output voltage drops and the lower voltages are not acceptable for this application.





Figures 24-26: Output Voltage vs Output Resistance

As the graphs indicate the output voltages go up steadily with the resistance, until the output voltage tops out at roughly 3.4 volts. And when the two groups of graphs are compared it is easy to see that the maximum output power is achieved at the lowest resistance setting that still achieves the maximum output voltage.

Subsystem 5: Control Circuit Design

The main goal of the CC430 microcontroller is to minimize power consumption while it performs each of its tasks. The microcontroller’s primary functions consist of 1) taking voltage readings from each energy harvesting module, and 2) wirelessly communicating system health statistics to a remote laptop. For each task, power consumption was measured. The results are outlined in the tables below.

Table 6: CC430 Power Consumption While Implementing Control Algorithm

Task 1: CC430 Voltage Readings Power Consumption	
Current (mA)	30
Voltage (V)	3
Total Power	90 mW

Table 7: CC430 Power Consumption While Wirelessly Transmitting Data

Task 2: Wireless Communication Power Consumption		
Power Readings	868 MHz	400 MHz
Current (mA)	35	30
Voltage (V)	3	3
Total Power	105 mW	90 mW

Table 8: CC430 Overall Power Consumption

Tasks Combined: CC430 Overall Power Consumption		
Power Readings	Task 1&2 Actual	Desired Results
Current (mA)	33	2
Voltage (V)	3	16.6
Total Power	99 mW	33.2 mW

As presented in Table 8, the power consumption is almost 3 times higher than desired. Using the CC430 microcontroller, low power modes are available to reduce power consumption of the device. However, in implementing Task 1 and 2, I was unable to properly implement the low power modes due to unknown software or hardware issues. Initially, I suspected something as wrong with my wireless communication program implementation. However, after re-writing the

program using different software libraries, I verified that my program worked and the low power modes were not working properly. As a second solution, I attempted forcing the low power modes through hardware implementation (by forcing certain registers low); however, this also proved unsuccessful. Besides from the power limitations, the microcontroller performed its tasks smoothly and quickly, and effectively managed and monitored the power flow.

CHAPTER IV

CONCLUSIONS AND FUTURE WORK

The success of the prototype design of the SmartShelter was inconclusive due to module failures (specifically the kinetic and microcontroller subsystems). Because we ran into unanticipated problems with these modules, we were unable to reproduce several of the same modules, and we were also unable to combine the entire system and test the prototype design. If problems with the subsystems are corrected, our current results show that our sustainable power system will yield an output of a few milliwatts of power.

Thus far, the solar energy harvester yields the maximum power output and looks more promising than other modules. We will continue testing other modules so that we can get higher efficiency and finally combine all the modules so that they can function as one a single harvester or source of power. Further expansion of the current modules will yield higher power output.

REFERENCES

1. DelRosario, Eduardo D. *NDRRMC Update: Effects of Typhoon "YOLANDA" (HAIYAN)*. Rep. no. 107. Quezon City: National Disaster Risk Reduction and Management Center, 2014. *ReliefWeb.int*. United Nations Office for the Coordination of Humanitarian Affairs, 14 Mar. 2014. Web. 30 Mar. 2014.
2. *Public Health Risk Assessment and Interventions: Typhoon Haiyan*. Phillipines: WHO Western Pacific Regional Headquarters, 2013. *Publications*. World Health Organization, 16 Nov. 2013. Web. 30 Mar. 2014.
3. "Mass Care Housing in Tents." *Disaster Survival*. Federal Emergency Management Agency, 17 Aug. 2013. Web. 30 Mar. 2014.
4. Giaccone, Gregory D. *An Evaluation of the Use of Portable Generators and Carbon Monoxide Poisonings and Deaths Following Hurricanes in Florida*. Rep. Delray Beach: Delray Beach Fire Rescue, 2008. U.S. Fire Administration Reports. Federal Emergency Management Agency, Feb. 2008. Web. 30 Mar. 2014.
5. "Conservation of Energy." *Encyclopaedia Britannica. Encyclopaedia Britannica Online Academic Edition*. Encyclopædia Britannica Inc., 2013. Web. 01 Dec. 2013.
6. V. Leonov, T. Torfs, P. Fiorini, and C. Van Hoof, "Thermoelectric Converters of HumanWarmth for Self-Powered Wireless Sensor Nodes," *IEEE Sensors Journal*, vol. 7, no. 5, pp. 650–657, May 2007.

7. T. Becker, M. Kluge, J. Schalk, T. Otterpohl, and U. Hilleringmann, "Power management for thermal energy harvesting in aircrafts," *IEEE Sensors*, pp. 681–684, Oct.2008.
8. J. Haidar and J. Ghojel, "Waste heat recovery from the exhaust of low-power dieselengine using thermoelectric generators," *International Conference on Thermoelectrics*,pp. 413–418, 2001.
9. A. K. Hyder, R. L. Wiley, G. Halpert, D. J. Flood, and S. Sabripour, *Spacecraft PowerTechnologies*. Imperial College Press, 2000.
10. M. Kishi, H. Nemoto, T. Hamao, M. Yamamoto, S. Sudou, M. Mandai, and S. Yamamoto, "Micro thermoelectric modules and their application to wristwatches as anenergy source," *International Conference on Thermoelectrics*, pp. 301–307, 1999.
11. Nolas, G. S., J. Sharp, and H. J. Goldsmid. *Thermoelectrics: Basic Principles and New Materials Developments*. Berlin: Springer, 2001. Print
12. S. P. Sukhatme and J. K. Nayak, *Solar Energy: Principles of Thermal Collection and Storage*, 3e, 3rd ed.McGraw-Hill Education (India), 2009
13. Raju, Murugavel, and Mark Grazier. "Energy Harvesting." *Ti.com*. Texas Instruments, Apr. 2010. Web.
14. Roberto Faranda, S.L., "Energy Comparison of MPPT Techniques for PV Systems", *WSEAS Trans. On Power Systems*, vol. 3, No.6.
15. Manbachi, A and Cobbold R.S.C. (2011). "Development and Application of Piezoelectric Materials for Ultrasound Generation and Detection". *Ultrasound* **19** (4): 187-196
16. Woldemar Voigt, *Lehrbuch der Kristallphysik* (Berlin, Germany: B. G. Teubner, 1910)

17. Katzir, S. (2012-06-20). "Who knew piezoelectricity? Rutherford and Langevin on submarine detection and the invention of sonar"
18. Roundy, Shad, Paul K. Wright, and Jan Rabaey. "A Study of Low Level Vibrations as a Power Source for Wireless Sensor Nodes." *Computer Communications* 26.11 (2003)
19. N. Tesla, "Apparatus for transmitting electrical energy," U.S. Patent 1 119 732, Dec. 1914
20. N. Tesla, "The true wireless," *Electrical Experimenter*, May 1919.
21. N. Tesla, *Experiments With Alternate Currents of Very High Frequency and Their Application to Methods of Artificial Illumination*. New York, NY, USA: AIEE, May 20, 1891.
22. W. W. Massie and C. R. Underhill, "The future of the wireless art," *Wireless Telegraphy Telephony*, pp. 67–71, 1908
23. Garnica, J., R. A. Chinga, and Lin Jenshan. "Wireless Power Transmission: From Far Field to Near Field." *Proceedings of the IEEE* 101.6 (2013): 1321-331. Web. 21 Nov. 2013. <<http://ieeexplore.ieee.org>>
24. W. C. Brown, "The history of power transmission by radio waves," *IEEE Trans. Microw. Theory Tech.*, vol. MTT-32, no. 9, pp. 1230–1242, Sep. 1964
25. Powercast "User's Manual TX91501 – 915 MHz Powercaster Transmitter" TX91501 datasheet, 2010
26. "Design Simulation and Device Models." Linear Technology -. N.p., n.d. Web. 25 Jan. 2014.
27. "EDA Software | Electronic Design Automation | Altium." N.p., n.d. Web. 25 Jan. 2014.