

**THE EFFECTIVENESS OF THE CAUSE-MAP SYSTEM IN TEACHING
INTERCONNECTED COMPLEX EARTH SYSTEMS IN A TEXAS PRIVATE
SCHOOL**

A Thesis

by

PATRICIA ANN FORSHEE

Submitted to the Office of Graduate Studies of
Texas A&M University
in partial fulfillment of the requirements for the degree of

MASTER OF SCIENCE

Approved by:

Co-Chairs of Committee, John Giardino
Carolyn Schroeder
Committee Member, John Vitek
Head of Department, John Giardino

December 2012

Major Subject: Geology

Copyright 2012 Patricia Ann Forshee

ABSTRACT

The six subsystems of Earth (atmosphere, hydrosphere, lithosphere, biosphere, cryosphere and anthroposphere) are complex and dynamic. Because all subsystems are linked, study from an independent perspective and a composite perspective is fundamental. Unfortunately, because of current instructional methods, students tend to consider these systems unrelated and use linear cause and effect models where little to no interaction occurs between different systems and the components. The simplistic and incorrect view of systems is the fundamental reason more education about Earth systems science is necessary in the K-12 curriculum.

In this study, the Cause-MaP system of studying complex Earth systems in a private intermediate school in Texas was evaluated. The objective was to ensure that students are more aware of how Earth affects them and vice versa. An added benefit of the study was the opportunity to teach scientific reasoning. Students completed a pre-unit test to measure *a priori* knowledge. The students then worked through a modified Cause-MaP system in which they took notes in a structured table format; then each created a concept map. Students completed these steps for two subsystems: hydrosphere and lithosphere. The individual concept maps were used to assess knowledge and understanding of the individual systems by each student. At the end of the unit, students created composite concept maps which included each system they studied in this unit, to illustrate the interconnectedness of Earth systems. Based on the number of components and processes

included, the students' maps were evaluated to determine their understanding of the interactions between multiple Earth systems. The students' maps were grouped based on the number of components and processes included in the concept maps. A post-unit test was also administered, which included two similar questions. The pre-unit test was completed again to check the overall progress of the students involved in this study. The students showed, with practice and encouragement from their instructor, that they recognize intersystem connections in complex Earth systems. With more integration of programs like these, students will become more proficient in recognizing system interactions.

To my wonderful family and friends who have encouraged me through pep talks, many hugs, and unceasing prayer.

ACKNOWLEDGEMENTS

I would like to thank God with whom all things are possible. I would also like to thank all of my family and friends for their constant prayer.

I would like to thank my committee chairs, Dr. Giardino and Dr. Schroeder, as well as my committee member, Dr. Vitek who have taught me invaluable lessons, and cultivated and encouraged my research topic and in turn my thesis. They have blessed my time as a graduate student and for that I am grateful.

A special thanks to my friends, professors, and colleagues in the College of Geoscience and the Department of Geology and Geophysics for being a part of my Aggie family.

Finally, thanks to my mother and father for their boundless encouragement and for teaching me to work hard, my in-laws for their support and encouragement, and to my husband for his constant love and support.

TABLE OF CONTENTS

	Page
ABSTRACT	ii
DEDICATION	iv
ACKNOWLEDGEMENTS	v
TABLE OF CONTENTS	vi
LIST OF FIGURES.....	vii
LIST OF TABLES	ix
INTRODUCTION.....	1
OBJECTIVES	4
METHODS.....	7
DATA ANALYSIS	13
Student Population	13
Pre-test and Post-test	14
Rock Cycle	17
Composite Cycle Diagrams.....	20
End of Unit Test	24
How These Students Compare to the Idealized Standard	29
How These Students Compare to Their Public School Peers	31
DISCUSSION AND CONCLUSION.....	35
REFERENCES.....	38
APPENDIX A	39
APPENDIX B	51
APPENDIX C	54

LIST OF FIGURES

FIGURE		Page
1	Exam question used by Clark et al. (2009) in conjunction with question 2 above.....	10
2	Question 14 from the end of unit test.....	10
3	Question 15 from the end of unit test.....	11
4	Question 15 from the pre-test.....	15
5	Graph depicting the number of correct answers for each question on the pre-test vs. the number of correct answers on the post-test	17
6	Student number seven's answers to the questions in step 1 of the Cause-MaP process.....	18
7	Student number ten's answers to the questions in step 1 of the Cause-MaP process.....	19
8	Idealized version of the composite cycle diagram the students were asked to draw.....	21
9	The composite cycle diagram created by Group 3.....	22
10	"The lithosphere can be moved into the mantle by slab-pull. Slab-pull is when two plates are converging and one slides under the other." Student 10's answer to question 14 from the end of unit test.....	25
11	"The plates on "A" could shift causing an earthquake, which makes it go down to "B"." Student 11's answer to question 14 from the end of unit test.....	26

34	weathering, erosion, sedimentation, cementation, and compaction occur to make it a sedimentary rock. Then the rock gets weathered again and becomes sediment.” Student 5’s answer to question 15 from the end of unit test.	28
13	“First, the volcano erupts then the lava goes towards the ocean. Next the water cools it. Finally, lava dries on the beach.” Student 3’s answer to question 15 from the end of unit test.....	29
14	An excerpt of the American Association for the Advancement of Science, Atlas of Science Literacy, Vol. 1, 2001, page 51, concept map which specifically addresses grades six through eight (Project 2061, 2001, pg 51).	30
15	Question 23 from the 2009 fifth grade science TAKS test.	32
16	Question number 7 from the pre-test/post-test.	33
17	Question 15 from the post-unit test.	34
"		
"		
"		
"		
"		

LIST OF TABLES

TABLE		Page
1	Structured questions with example answers from step 2 of the Cause-MaP process(Clark et al., 2009).	8
2	Tabulation of the answers, from step 2 of the Cause-MaP process, into a structured argument table (Clark et al., 2009).....	9
3	Amount of time each student involved in the study has been enrolled in the school as of the end date of this study.....	13
4	Grading rubric for the composite cycle diagrams.	23

INTRODUCTION

A system is a regularly interacting or interdependent group of items forming a unified whole. A system can be defined as either open or closed. In a closed system, only energy crosses the boundary of the system to influence variables in that system. Mass cannot enter or depart the closed system. In an open system, energy and mass can cross the boundary of a system such that variables outside the boundaries of a defined system can interact with different aspects of the system.

Earth consists of six distinctive subsystems: the atmosphere, the hydrosphere, the lithosphere, the biosphere, the cryosphere and the anthroposphere (Clark et al., 2009). Although each subsystem can be studied independently of the other subsystems, one must take into account that each component in a system not only affects every other component in the subsystem but those in other subsystems as well. All the subsystems of Earth are linked. These interactions are important because of the interconnectedness of variables in all systems. As a result of these interactions, it is relevant to study the systems from an independent perspective as well as a composite perspective. In Earth Systems Science, Earth is considered a dynamic system with “interactive phenomena, processes and cycles” (Schroeder, 2006; 19). In the systems of Earth, interacting components include humans. Because of this, students must recognize how all variables in a system impact each other, especially how humans affect their surroundings and vice versa (Assaraf and Orion, 2005). Unfortunately, students tend to consider these systems

as conglomerates of unrelated parts using linear cause and effect models – where little to no interactions occur between different systems and their components (Assaraf and Orion, 2005; Raia, 2008; Clark et al., 2009).

The simplistic and incorrect view of systems, especially Earth systems, is the fundamental reason more education about Earth systems science is necessary in the K-12 curriculum. Implementing Earth systems science in classrooms provides educators an opportunity to integrate inquiry-based instruction into the classroom (Schroeder, 2006). Approaching the instruction of Earth systems science from an inquiry-based approach gives educators the opportunity to present ill-defined problems, which are typically missing in public education, in place of well-defined problems that provide too much information (Rostan, 1994; Schroeder, 2006). Introducing ill-defined problems, like those in Earth science, is also an important step in increasing authentic inquiry in public school classrooms in ways that are relevant to students (Schroeder, 2006). Ill-defined problems include many independent variables and few dependent variables, they do not have “correct” or “incorrect” answers, and no “correct” steps exist to solve the problem. Well-defined problems do not leave room for scientific questions because strictly structured steps exist to solve the problems and a right or wrong answer exists.

In this study, the Cause-MaP method is used to study how students learn Earth systems science. Cause-MaP stands for ‘Cause, Matter, and Process’ and was originally designed to “enhance non-science major undergraduates’ understanding of complex Earth

systems.” (Clark et al., 2009; 233). Cause-MaP provides a structured order for students to work through individual systems and combinations of multiple systems, where everything that affects the system is compiled to create a map showing how matter flows through the system (Clark et al., 2009).

OBJECTIVES

This study examines the students' abilities to solve and understand complex Earth systems. The students learned and executed a modified Cause-MaP problem solving method. At the beginning of the geology unit of the science curriculum, students were administered an assessment test. The same test was administered as a post-test at the end of the learning unit to assess the students' progress and understanding of complex Earth systems.

This study integrated the following TEKS (Texas Essential Knowledge and Skills) for sixth grade science:

“(3) Scientific investigation and reasoning. The student uses critical thinking, scientific reasoning, and problem solving to make informed decisions and knows the contributions of relevant scientists. The student is expected to:

(A) in all fields of science, analyze, evaluate, and critique scientific explanations by using empirical evidence, logical reasoning, and experimental and observational testing, including examining all sides of scientific evidence of those scientific explanations, so as to encourage critical thinking by the student;

(B) use models to represent aspects of the natural world such as a model of Earth's layers;

(C) identify advantages and limitations of models such as size, scale, properties, and materials; and

(D) relate the impact of research on scientific thought and society, including the history of science and contributions of scientists as related to the content.

(10) Earth and space. The student understands the structure of Earth, the rock cycle, and plate tectonics. The student is expected to:

(A) build a model to illustrate the structural layers of Earth, including the inner core, outer core, mantle, crust, asthenosphere, and lithosphere;

(B) classify rocks as metamorphic, igneous, or sedimentary by the processes of their formation;

(C) identify the major tectonic plates, including Eurasian, African, Indo-Australian, Pacific, North American, and South American; and

(D) describe how plate tectonics causes major geological events such as ocean basins, earthquakes, volcanic eruptions, and mountain building.

Private schools in Texas are not required to use the TEKS as their standards. The teacher in this classroom chose to follow the TEKS because the school only included grades kindergarten through eight, and many students move to the public school system

after the eighth grade. This study tested the students' ability to transfer knowledge between the different Earth systems. Many interconnecting variables exist between Earth systems. Earth systems, however, are traditionally taught as isolated, stand-alone systems, in turn teaching students to associate variables with specific systems (Clark et al., 2009). The Cause-MaP method is designed to teach students about complex systems in a way that will help them recognize dependent variables that are present in multiple Earth systems and how each system affects other systems.

This research studied middle school students' abilities to follow matter through a dynamic system and to identify the relationships between different systems. This study shows that with practice students will transfer knowledge from one system to the next and from one problem to another in varying degrees. Students traditionally have difficulty understanding dynamic systems because of the many dependent variables and limited independent variables (Clark et al., 2009). These difficulties are evident in students' isolation and fragmentation of scientific concepts (Clark et al., 2009). The students' learning was evaluated based on the differences in their answers to the pre and post-unit surveys, as well as the post-unit test and the sophistication of the students' concept maps. Sophistication was assessed through constant comparative analysis.

METHODS

The two units, in which the students received instruction on the rock cycle and the mantle convection cycle, lasted six school weeks. Students were recruited from one intermediate, private school classroom in Texas. The students first took a pre-test. The pre-test was created using the Geoscience Concept Inventory (GCI), included in appendix C on pages 54 through 57, and was re-administered at the end of the unit as a post-test. The GCI is designed for grades eight through twelve. The GCI format requires 15 questions to be included in the test. Only four questions were available which directly related to the material presented in this study, and the remainder of the questions were chosen to fill in the additional required questions on the test.

Students received instruction on the lithosphere and reviewed prior instruction on the hydrosphere. The instruction was delivered in a lecture style with accompanying PowerPoint™ presentations and videos from Discovery Education™ for visual aid. Students also used charts to organize their notes. For each sphere, the students studied a cycle contained in the sphere, such as the relationship between the water cycle and the hydrosphere. They also analyzed how the water cycle and lithosphere interact. The students completed a modified Cause-MaP analysis on each sphere, one sphere at a time.

The first step in the Cause-MaP process had the students answering a set of five questions for each process in the system (Table 1). The first question (Question 1) states

“what matter is being traced” (Clark et al., 2009; 235)? Question 2 queried “what is the process occurring” (Clark et al., 2009; 235)? Question 3 asked “what is causing the process to occur” (Clark et al., 2009; 235)? Question 4 questioned “what is the scientific terminology for the process” (Clark et al., 2009; 235)? Question 5 challenged “what is changing or moving” (Clark et al., 2009; 235)? The students involved in this study did not directly answer the questions; however they did answer these using a scaffolded method. The scaffolded method used the chart from the second step to help the students take notes. The second step in the process had students tabulate the answers into a structured argument table, similar to the one shown in Table 2 below. This step has been modified to fit in the curriculum as notes and to make the Cause-MaP analysis more age appropriate. An example of an idealized table for each system is located in Appendix B on pages 51 through 52. The last step is to create a box-and-arrow diagram.

QUESTION	EXAMPLE
Q1. What MATTER is being traced?	Q1 answer. Water
Q2. What is the LOCATION where the process is occurring? (Matter is moving within a sphere, or from where to where?)	STRUCTURED ARGUMENT: <i>In / From the Q2 answer, the Q3 answer drives Q4 answer, which is / of Q5 answer.</i>
Q3. What is CAUSING the process to occur?	
Q4. What is the scientific TERMINOLOGY for the PROCESS?	EXAMPLE: From the coffee to the atmosphere , heat drives evaporation of liquid water to water vapor .
Q5. What is changing or moving? (EXPLAIN what is happening to matter.)	

Table 1: Structured questions with example answers from step 2 of the Cause-MaP process (Clark et al., 2009). Reprinted with permission from Clark et al, 2009 and the Journal of Geoscience Education volume 57 issue 4 <http://nagt-jge.org/toc/jgee/57/4>

<i>In / From the</i>	Q2. What is the LOCATION where the process is occurring? (Matter is moving within a sphere, or from where to where?)	Q3. What is CAUSING the process to occur?¹	<i>drives</i>	Q4. What is the scientific TERMINOLOGY for the process?	<i>which is / of</i>	Q5. What is changing or moving? (EXPLAIN what is happening.)	Mental cues and details (assessable knowledge)
<i>From the</i>	hot cup of coffee to the air	heat	<i>drives</i>	evaporation	<i>which is</i>	a phase change of liquid water to water vapor	water vapor is invisible
<i>In the</i>	atmosphere	heat loss	<i>drives</i>	condensation	<i>of</i>	water vapor to liquid water	liquid water is visible
<i>In the</i>	atmosphere	thermal variations	<i>drives</i>	advection	<i>of</i>	liquid water away from the hot coffee	convection of air over hot coffee
<i>In the</i>	atmosphere	vapor pressure	<i>drives</i>	evaporation	<i>which is</i>	a phase change of liquid water to water vapor	

Note:

¹The level to which causes are described will depend upon the nature of the course objectives and the student population

Table 2: Tabulation of the answers, from step 2 of the Cause-MaP process, into a structured argument table (Clark et al., 2009). Reprinted with permission from Clark et al, 2009 and the Journal of Geoscience Education volume 57 issue 4 <http://nagt-jge.org/toc/jgee/57/4>

After completing the Cause MaP analysis on one of the spheres, the students used the same method to analyze the second sphere. After the two spheres were analyzed, students were tested on their content knowledge. On the test two questions were similar to the ones, shown below, that Clark et al. (2009) used:

1. “Summer is upon us and it is frequently muggy (i.e., hot and sticky) outside. The mugginess is due to heat and water vapor in the air. **What is the main way for the water vapor to leave the atmosphere?** (include all necessary steps)” (Clark et al., 2009; 237)
2. “Looking at the following figure [Figure 1], **please show how water from the swimming pool could end up in the neighbor’s carrot.** Answer using the structured argument table and a box-and-arrow diagram.” (Clark et al., 2009; 238)

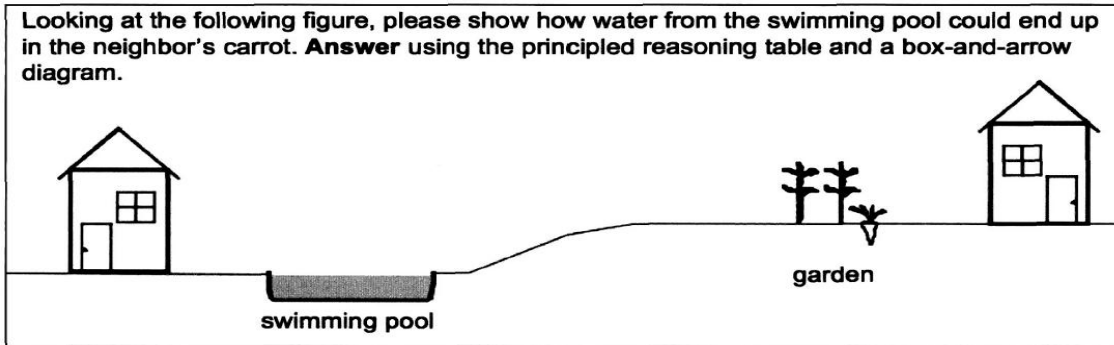

Figure 1: Exam question used by Clark et al. (2009) in conjunction with question 2 above. Reprinted with permission from Clark et al, 2009 and the Journal of Geoscience Education volume 57 issue 4 <http://nagt-jge.org/toc/jgee/57/4>

The questions used on the final test for the test subjects are shown below, in Figures 2 and 3.

14. Explain how the part of the lithosphere marked A on the map below can be moved into the layer of the Earth marked B. Describe the steps and draw a diagram.

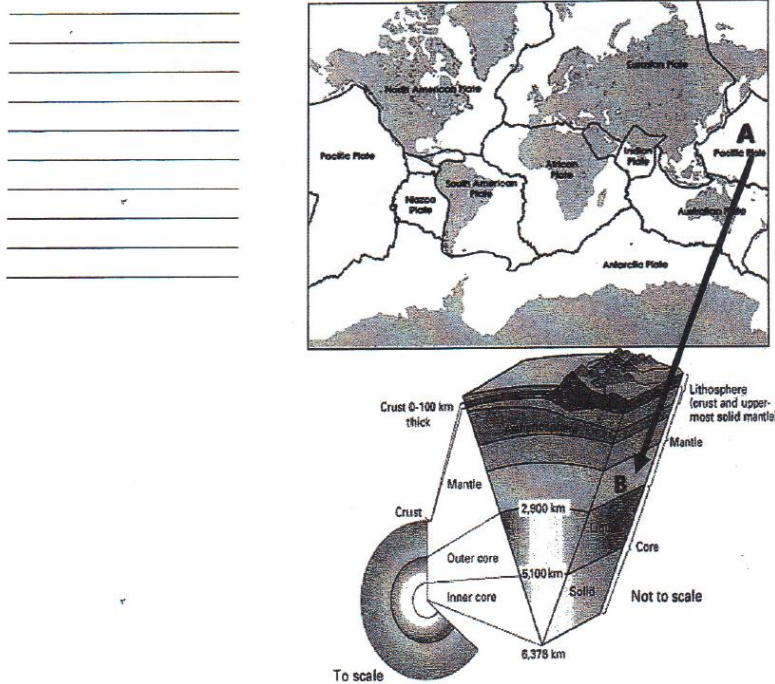

Figure 2: Question 14 from the end of unit test.

15. Describe how lava from a volcano can become sand on a beach. Use a rock cycle diagram, including the arrows showing how the rock material changes to help you explain the process.

Figure 3: Question 15 from the end of unit test.

These questions were derived from the original questions used in Clark et al. (2009).

The root questions are the same. Question 15 above is derived from Question 1 from Clark et al. (2009), while Question 14 above is derived from Question 2 from the same paper. The questions from Clark et al. (2009) were not used verbatim because the water cycle was not presented in detail in class. The water cycle was only presented as a review, and, therefore, not included on the unit content knowledge test by the instructor. The rock cycle and plate tectonics were the main focus of the curriculum during the six weeks, so the questions were drawn from those two topics. Questions 14 and 15 were the only information from the unit content knowledge test that was analyzed.

It was important that the topics specified by the Texas state objectives, the Texas Essential Knowledge and Skills (TEKS), were covered as well as the integral information the students needed to complete the analysis process. Because of time constraints, however, the students did not complete all of the steps for all of the cycles. For the rock cycle, the students did all three steps of the Cause-MaP analysis in a quiz style. The quiz was completed over a two day period. The amount of questions and

white space on the paper overwhelmed many of the students and they took more time than anticipated. These results led to rescaffolding the lesson plans so that step one was combined with step two and integrated into the students note taking for the mantle convection cycle. Scaffolding is the infrastructure through which a teacher provides support for students. As students achieve learning goals their need for support decreases and the scaffolding may be reduced accordingly. The curriculum schedule did not allow time for the students to create a box-and-arrow diagram of the mantle convection cycle. For the third cycle, the water cycle, the curriculum did not allow time for students to use a notes chart or create a box-and-arrow diagram. The students were, however, able to create a composite cycle diagram of all three cycles together. The students worked in groups of three to create these diagrams; see Appendix A, pages 48 through 50.

DATA ANALYSIS

Student Population

The students included in this study attend a Christian, private school in south Texas which serves students from pre-school through the eighth grade. The school teaches a young-Earth creationism science curriculum. Ten students from the sixth grade science class participated in this study. Table 3, below, shows the amount of time each student involved in this study has been enrolled in the school as of the end date of this study.

Student #	Years	Months
1	2	1
2	5	4
3	0	9
5	3	8
6	5	4
7	5	4
9	2	4
10	5	4
11	3	9
12	0	1

Table 3: Amount of time each student involved in the study has been enrolled in the school as of the end date of this study.

This study did include the special needs students in the class. Modifications were made to the study in accordance with their Individual Education Plans (IEPs). For this study, the modifications consisted of giving the students extra time to complete the assignments.

Pre-test and Post-test

Students were administered a pre-test and post-test which was created using the Geosciences Concept Inventory. The pre-test encompassed some material the students had not learned about yet and also reflected the young Earth-creationism curriculum that is taught in this school. A copy of the pre-test/post-test can be found in Appendix C on pages 54 through 57. One question, in particular, showed the extent to which the students believed in a young Earth. Question fifteen, seen in Figure 4 below, addresses the appearance of different forms of life from the formation of the Earth to present day.

15. Which of the figures below do you think most closely represents changes in life on Earth over time?

Choose one: **A** **B** **C** **D** **E**

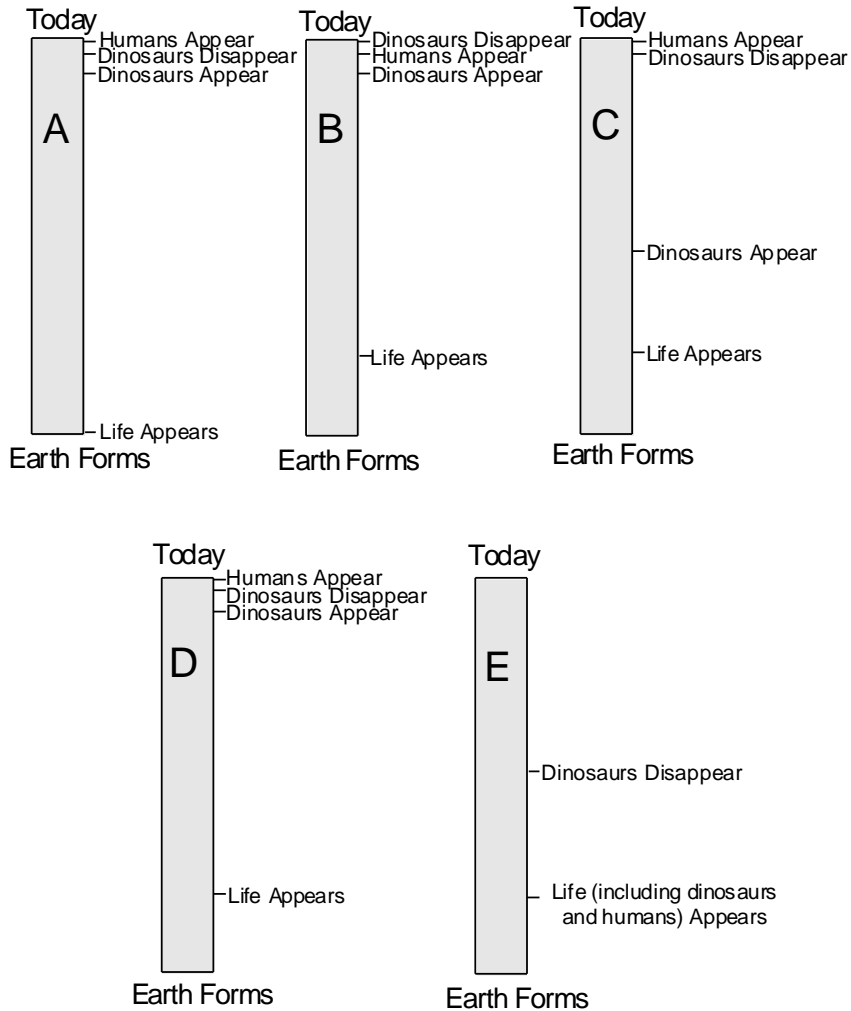

Figure 4: Question 15 from the pre-test.

Three out of eight students, students 2, 3, and 9, answered “E” to this question. The correct answer to this question is “D” and only one student out of eight answered the question correctly. This is a direct reflection of the curriculum the students are taught at

this school; student 2 has attended this school for six years, student 3 has attended for one year, and student 9 has attended for two and one half years. Answer “E” was even more prevalent in the post-test than in the pre-test with six out of nine students answering with letter “E”, including the student who answered correctly in the pre-test. Again only one student answered correctly, this time it was student 12, who transferred into the school from a local public school during the six weeks in which this research was conducted. Student 12’s results will be referenced specifically, but are not included in the comparative analysis because she was not present for the pre-test and the first half of the research. Her answer here is important; it is representative of the differences in curriculum between the local private and public schools. None of the other answers showed a significant correlation to the young Earth-creationism curriculum.

On a broader scale, no significant difference occurred between the number of correct answers observed on the pre-test and the number of correct answers observed on the post-test. Twenty-two correct answers were given on the pre-test and only three more correct answers on the post-test. It was necessary, therefore, to analyze the questions on an individual basis. Figure 5 below, compares the number of correct questions between the pre-test and post-test.

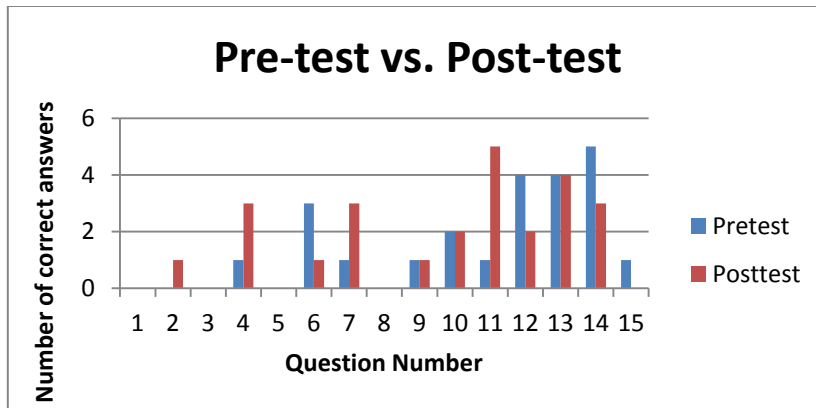

Figure 5: Graph depicting the number of correct answers for each question on the pre-test vs. the number of correct answers on the post-test

Question number 3 was thrown out because of an error which may have led students to answer incorrectly. In the pre-test and the post-test, no student answered questions 1, 5, or 8 correctly. Questions 6, 12, 14, and 15 had decreased numbers of correct answers from the pre-test to the post-test. It was thought for some time that a correlation might exist between some of the incorrect answers and the curriculum taught at the school. Upon further analysis, however, it appears that a correlation only exists between the curriculum and the answers to question 15. Questions 2, 4, 7, and 11 showed improvement from the pre-test to the post-test. All of the questions showing improvement addressed topics that were definitively covered in the six week curriculum.

Rock Cycle

The rock cycle was the only cycle for which the students completed the entire Cause-MaP process. After this, the process was modified based on the results of the rock cycle for age appropriateness and classroom time constraints. The first step in the Cause-MaP

process was to answer five leading questions. Student number seven consistently answered questions correctly throughout the study and Figure 6 is an example of some of student seven's above average answers.

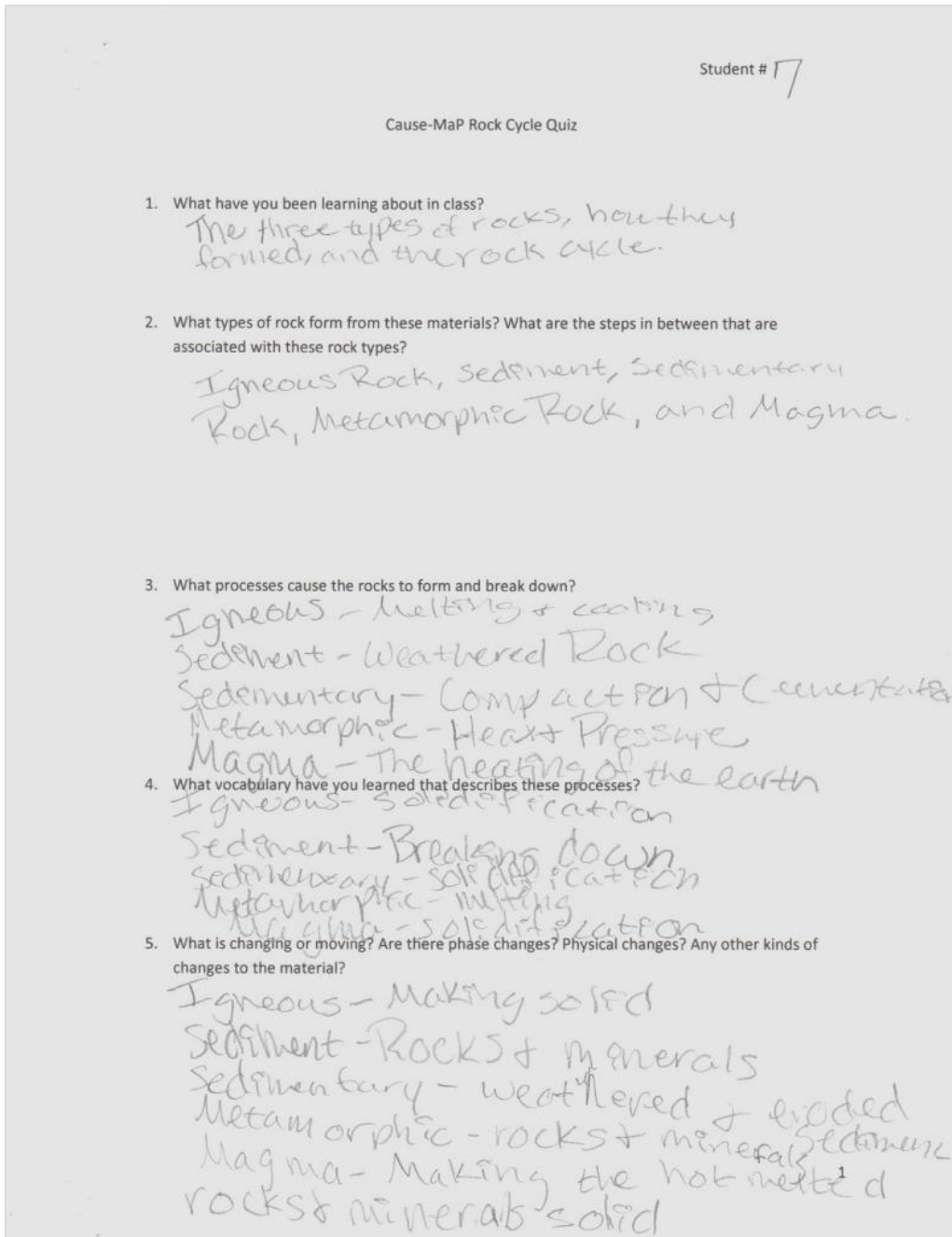

Figure 6: Student number seven's answers to the questions in step 1 of the Cause-MaP process.

Many students, however, were overwhelmed by the open-ended questions and the blank space on the paper. This led to many answers similar to student number 10's, in Figure 7 below, in which the student only partially answered the question.

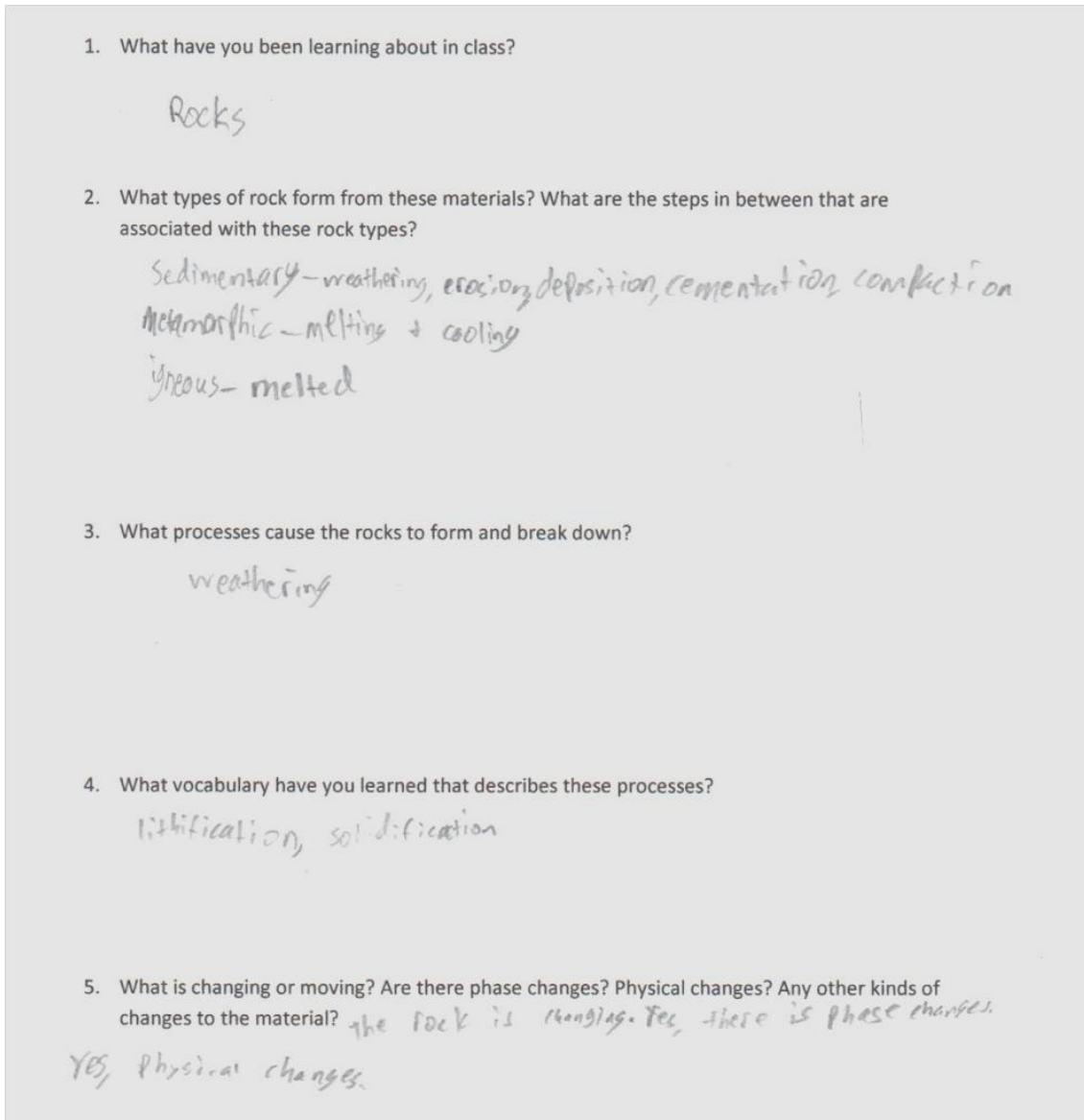

Figure 7: Student number ten's answers to the questions in step 1 of the Cause-MaP process.

Composite Cycle Diagrams

The students were divided up into three groups. Group one included students 2, 9, and 6; group two included students 1, 12, and 10; and group three included 11, 7, and 3. The students worked in these groups and were asked to create a poster which incorporated the rock cycle, plate tectonics/mantle convection cycle, and the water cycle. The students were also asked to show where and how these different cycles interact. Figure 8 below is an example of an ideal diagram.

The students drew their diagrams on large pieces of butcher paper. For analysis purposes, photographs were taken of the diagrams and then printed onto eight-and-a half inch by eleven inch computer paper. On the printouts of the photographs of the entire diagram some of the writing was too light to scan back in. To compensate for this, all of the writing was traced in blue ink and then analyzed in red ink. The printouts were then scanned to a PDF for use in this paper. None of the groups included the mantle convection cycle in their diagrams. Two of the three diagrams included world maps designating plate boundaries, and all three diagrams included the layers of Earth, although some were not drawn with scale in mind. All three diagrams included the rock cycle in one form or another. Only one diagram integrated the rock cycle with the water cycle, as shown in Figure 9 below.

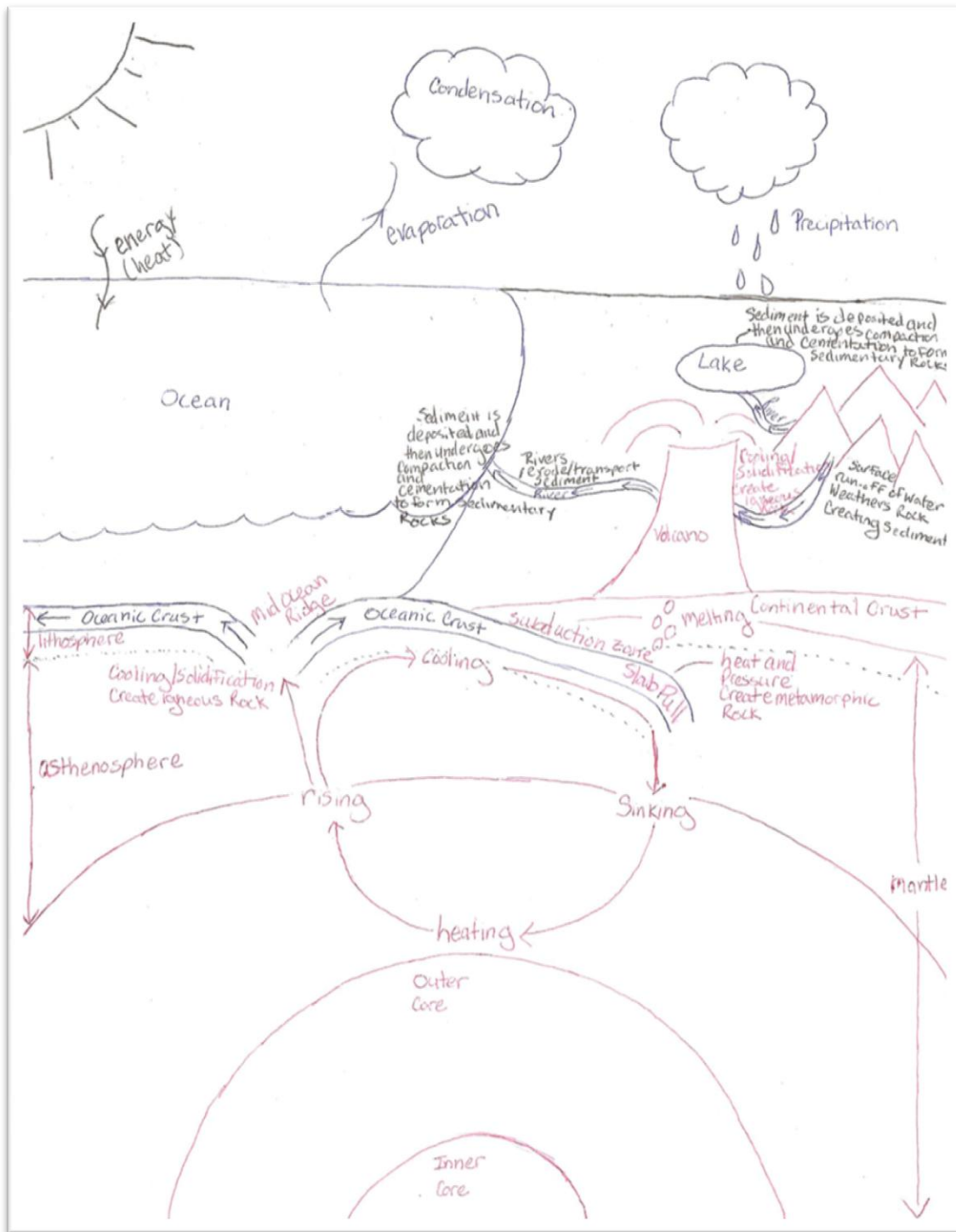

Figure 8: Idealized version of the composite cycle diagram the students were asked to draw.

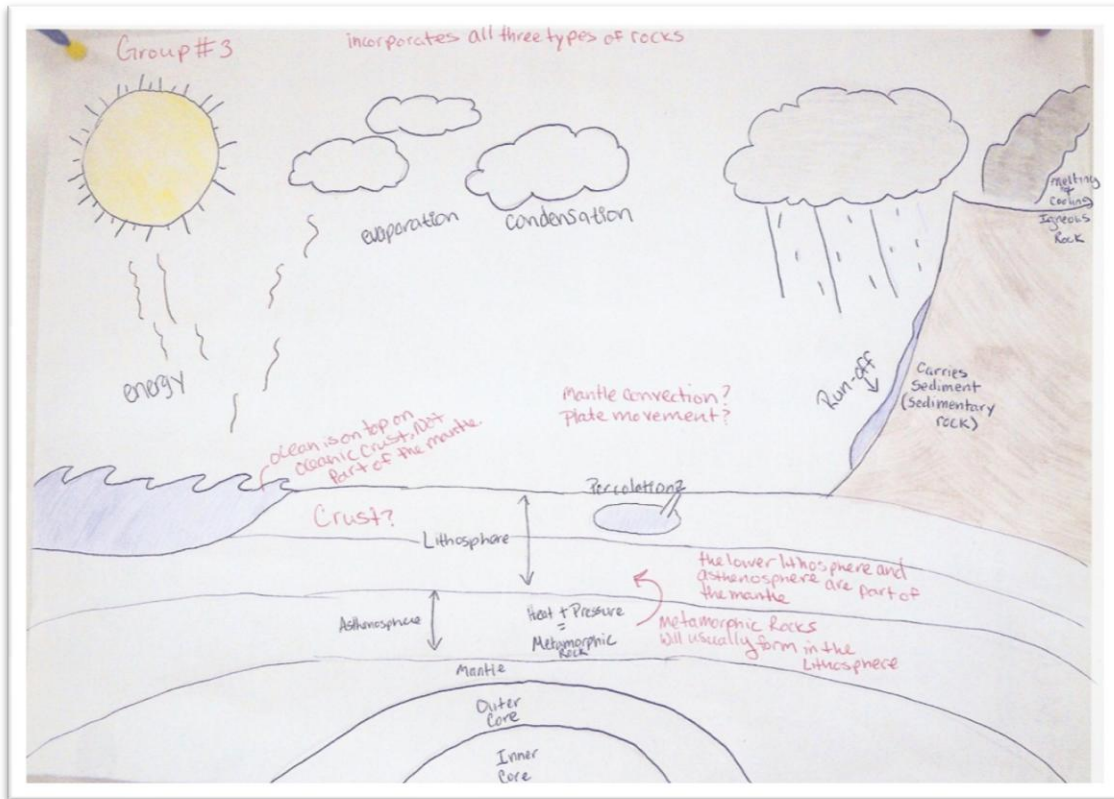

Figure 9: The composite cycle diagram created by Group 3.

Group three shows extensive connections between cycles. The students included all three main types of rock showing where they are formed, as well as one way in which the water cycle affects sediment in the rock forming process and how igneous rock is changed to sediment. Group one showed limited connections between the rock cycle and the water cycle, where as group two showed no connections between any of the cycles. All of these diagrams can be found in Appendix A on pages 48 through 50. Each diagram was analyzed for the key aspects outlined in the rubric featured in Table 4, on the next page. The completed rubrics for each group are located in Appendix C on pages 59 through 61.

	poor (1pt)	below-average (2pt)	average (3pt)	above-average (4pt)	excellent (5pt)	Total
vocabulary used	uses no appropriate vocabulary	uses some appropriate vocabulary for 1 of the systems	uses some appropriate vocabulary for 2 of the 3 systems	uses some appropriate vocabulary for all 3 systems	uses most appropriate vocabulary for all 3 systems	___/5
figures used	includes very few elements involved in the systems	includes some elements involved in 1 of the 3 systems	includes some elements involved in 2 of the 3 systems	includes some elements involved in all 3 systems	includes most elements involved in all 3 systems	___/5
relationships between earth systems	shows no interrelationship between the 3 systems	shows only slight relationship between two systems	shows integration between two systems	shows some relations between all three systems	shows intricate relations between all three systems	___/5
rock cycle	students' rock cycle is incorrect	students' rock cycle is partly correct with few to no big mistakes	students' rock cycle is mostly correct with no big mistakes	students' rock cycle is completely correct	students' rock cycle is completely correct and includes additional, unexpected, or outstanding features	___/5
water cycle	students' water cycle is incorrect	students' water cycle is partly correct with few to no big mistakes	students' water cycle is mostly correct with no big mistakes	students' water cycle is completely correct	students' water cycle is completely correct and includes additional, unexpected, or outstanding features	___/5
mantle convection cycle	includes layers of the earth, both physical and chemical	the layers are depicted keeping in mind the scale of the separate layers	the depiction includes crust subduction	the depiction includes mantle convection	the depiction includes temperature differentials as a reason for mantle convection	___/5

Table 4: Grading rubric for the composite cycle diagrams.

The diagrams were then ranked based on the numerical results of the rubric. Groups one and three had the highest numerical scores, with both receiving 19 points out of a possible 30. Group two had the lowest score, receiving 17 out of a possible 30. The main reason for such close scores was the absence of the mantle convection cycle in the students' diagrams. This mistake cost each group at least four points. The scores also suffered because students had trouble showing how the systems interact. Group three had the best understanding of how to illustrate the interaction between systems but lost points because of the scale used to depict the layers of Earth.

End of Unit Test

In addition to the pre-test and post-test the students took an end of unit test as well. On the test were two questions, shown in Figures 2 and 3 earlier on pages 19 and 20. The results of these questions were varied; showing many degrees of knowledge. Students were expected to answer these questions clearly and concisely. These questions were designed to be more complex than what the students went over in class so they would have to think through the problem critically and use higher level problem solving. As to be expected, some students did very well while others had a more difficult time.

Question 14 was analyzed based on the following elements:

Vocabulary: Students were expected to correctly use the vocabulary they learned in class to describe how rock in location "A" will eventually end up in location "B." This vocabulary includes: slab-pull, lithosphere, mantle, density, and subduction.

Content: The processes were expected to be in the correct order and it was important for the students to mention that the oceanic crust in location “A” will subduct beneath the continental crust and then be pulled down by gravity (slab-pull). Figure 10 below shows the most correct and complete answer for question 14. This answer shows comprehensive understanding of the slab-pull theory as well as an advanced understanding of plate tectonics.

14. Explain how the part of the lithosphere marked A on the map below can be moved into the layer of the Earth marked B. Describe the steps and draw a diagram.

The lithosphere can be moved into the mantle by slab-pull. Slab-pull is when two plates are converging, and one slides under the other.

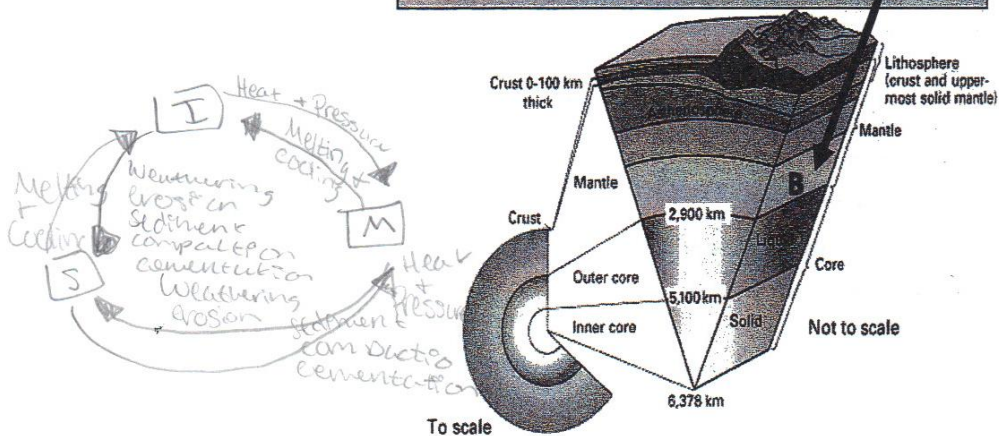
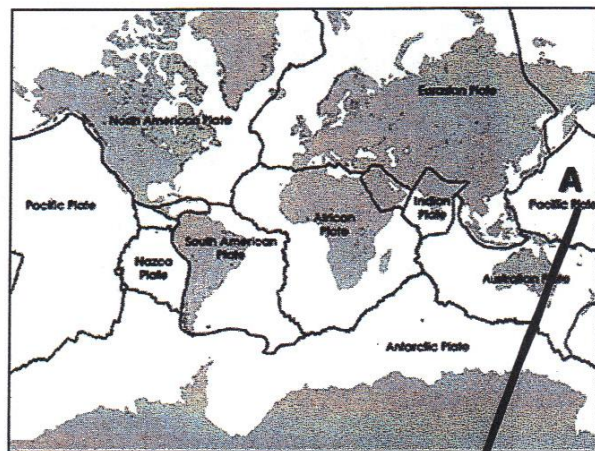

Figure 10: “The lithosphere can be moved into the mantle by slab-pull. Slab-pull is when two plates are converging and one slides under the other.” Student 10’s answer to question 14 from the end of unit test.

On the other end of the spectrum is the answer shown in Figure 11 below, which shows very little understanding of this concept. This answer indicates that the student has a very poor understanding of plate tectonics and a misconception about what geologic repercussions result from earthquakes.

14. Explain how the part of the lithosphere marked A on the map below can be moved into the layer of the Earth marked B. Describe the steps and draw a diagram.

The plates on "A"
 could shift
 causing an
 earth quake,
 which makes
 it go down
 to "B"

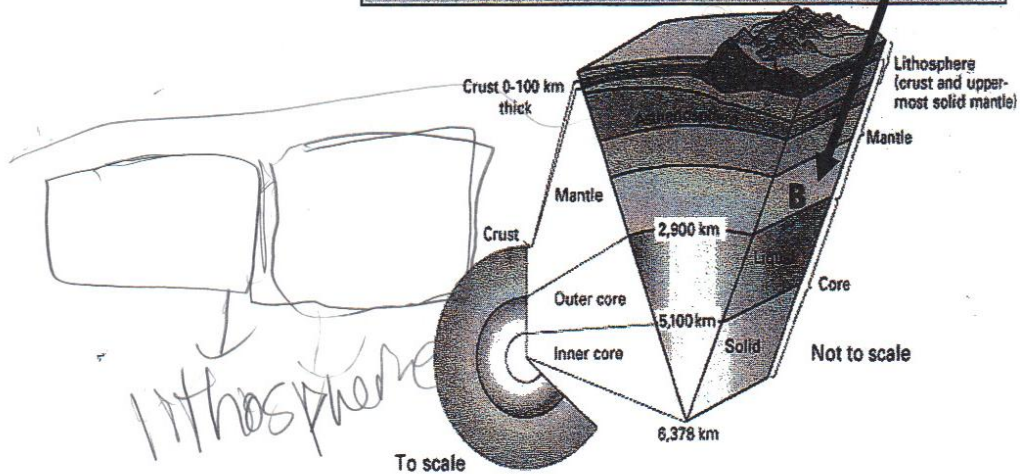
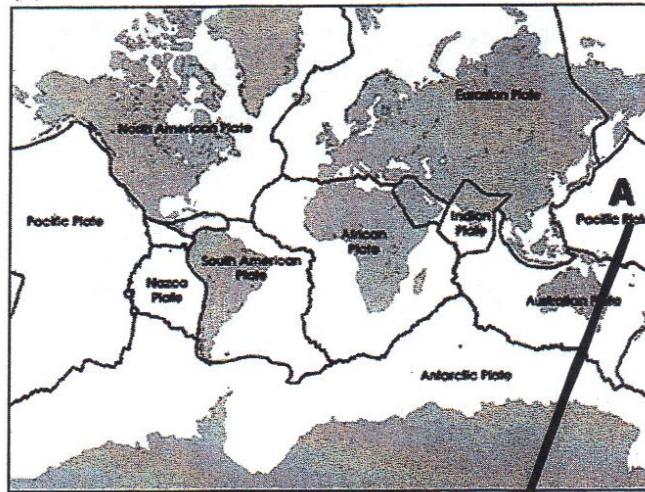

Figure 11: “The plates on “A” could shift causing an earthquake, which makes it go down to “B”.” Student 11’s answer to question 14 from the end of unit test.

Many answers fell in the middle and were correct but did not show the same understanding as student 10; all of which can be found in Appendix A on pages 39 through 47. Question 15 also had a wide range of answers and was analyzed based on the following elements:

Vocabulary: The students needed to correctly use the vocabulary describing the different processes and phases. Lava, cooling, igneous rock, weathering, erosion, and sediment were all words required for the answer to be complete and correct.

Illustration: Did the student's rock cycle show how the materials move from lava erupting from a volcano to sand on a beach?

Content: The processes were in the correct order. Students correctly distinguished weathering and erosion.

To answer this question students needed to synthesize the information they learned during their rock cycle lessons, as well as their own experiences and prior knowledge. Students were expected to realize that lava from a volcano would most likely have a higher elevation and be far enough from the ocean that it would need to be broken down into smaller pieces (weathered); would then be transported to the beach (erosion), and that these processes would result in the rock becoming sediment (sand). The answer in Figure 12, below, is an example of a complete and correct answer.

15. Describe how lava from a volcano can become sand on a beach.

Use a rock cycle diagram, including the arrows showing how the rock material changes to help you explain the process.

The lava cools and turns into igneous rock
and the weathering, erosion, sedimentation,
cementation, and compaction occur to
make it a sedimentary rock. Then the
rock gets weathered again and becomes
Sediment.

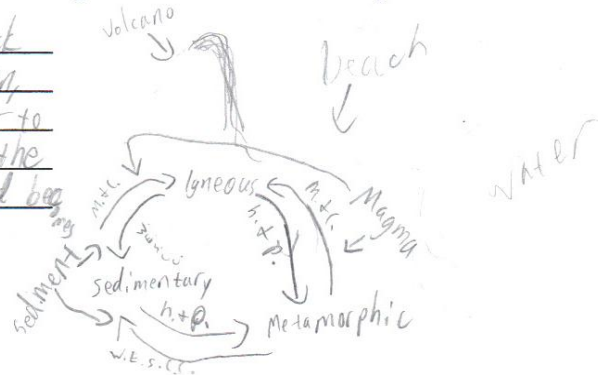

Figure 12: “The lava cools and turns into igneous rock and the weathering, erosion, sedimentation, cementation, and compaction occur to make it a sedimentary rock. Then the rock gets weathered again and becomes sediment.” Student 5’s answer to question 15 from the end of unit test.

This answer is correct and shows that the student understood the processes that need to occur in order for igneous rock to become sand; however, it also revealed a misconception formed when the student learned the rock cycle. A sedimentary rock does not need to form and then be broken down again in order to create sediment. Sediment is created when any type of rock is broken down into smaller pieces. Figure 13 is an example of an incorrect answer. The student did use some of the expected vocabulary properly; however, his concept of what causes the lava to cool in this situation is distorted. He also did not mention the sand (sediment), which is a key piece to this question.

15. Describe how lava from a volcano can become sand on a beach.

Use a rock cycle diagram, including the arrows showing how the rock material changes to help you explain the process.

First, The volcano erupts
then the lava goes towards
the ocean. Next, the water
cools it. Finally, Lava dries
on the beach.

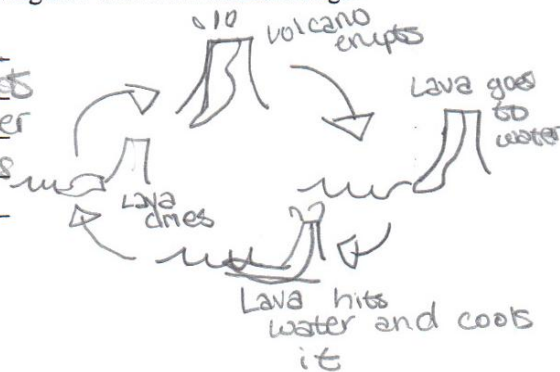

Figure 13: "First, the volcano erupts then the lava goes towards the ocean. Next the water cools it. Finally, lava dries on the beach." Student 3's answer to question 15 from the end of unit test.

How These Students Compare to the Idealized Standard

According to the American Association for the Advancement of Science, in their publication *Atlas of Science Literacy*, students' science education should follow the concept map found in Appendix B, on page 53, an excerpt of which is located in Figure 14 below (Project 2061, 2001, pg 51).

Many of the students in this study mastered most of objectives found in the sixth through eighth grade category, as well as some of the materials from the ninth through twelfth grade category. Although not all of the objectives were mastered, the students were familiarized with most of the others. The objectives, which include old-Earth science (highlighted in red) were not emphasized in the young-Earth curriculum taught at this school. Students also did not learn about glaciers and their effects on the surface of Earth during this study.

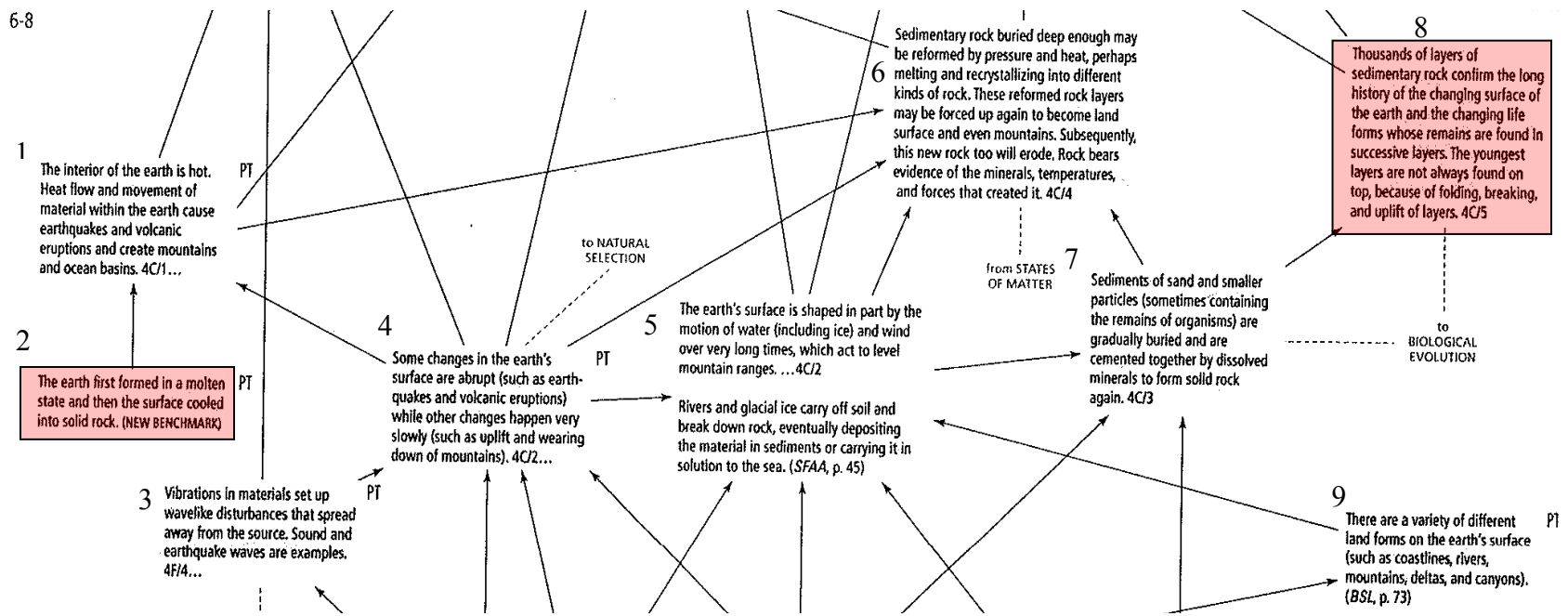

Figure 14: An excerpt of the American Association for the Advancement of Science, Atlas of Science Literacy, Vol. 1, 2001, page 51, concept map which specifically addresses grades six through eight (Project 2061, 2001, pg 51). Adapted and excerpted with permission.

Students were introduced to the objective labeled “1” in Figure 14 above through the mantle convection cycle. Based on the absence of the mantle convection cycle in the students’ composite diagrams (see Appendix A, pages 48 through 50), this objective was not mastered. Objectives “4” and “5” are very similar in that they both emphasize the interaction between the rock cycle and the water cycle. Both the end of unit test and the composite diagrams showed that the majority of students demonstrated their mastery of these objectives. All of the groups included water induced weathering and erosion in their composite diagrams. Question fifteen on the end of unit test also addressed the interaction between the water cycle and the rock cycle. To answer this question correctly, students needed to recognize that water and/or wind can cause weathering of volcanic rock and subsequent erosion of the sediments. Eight students provided answers to question fifteen on the end of unit test. Six out of eight students answered this question correctly, with half of them specifically including wind or water generated weathering and erosion in their answer.

How These Students Compare to Their Public School Peers

The Texas Assessment of Knowledge and Skills (TAKS) test is the Texas state standardized test. Students take the science TAKS test in grades 5, 8, 10, and 11. Because the subjects of this study were sixth graders, the fifth grade TAKS test was used to determine what the students in the local public schools are expected to know when they finish the fifth grade. This produced a minimum knowledge level at which the students participating in the study should be compared to their peers. Below, in Figure

15, is the question from the fifth grade science TAKS test, administered in April of 2009 that best relates to the contents of this study.

- 23** The Davis Mountains in West Texas used to be taller than they are now. Which of the following conditions most likely caused the mountains to become shorter over time?
- A** Heat and pressure
 - B** Soil deposition
 - C** Rain and wind
 - D** River formation

Figure 15: Question 23 from the 2009 fifth grade science TAKS test.

Out of 3021 students in two large independent school districts located in the same county as the private school in this study, 2311 (77%) students correctly answered the question. Question 23 from the 2009 fifth grade science TAKS test provides the most extensive comparison to the effectiveness of the curriculum in this study because of the emphasis placed on the interaction between the rock cycle and the water cycle. The participants in this study were asked many similar questions throughout the duration of the study. The first was presented in the pre-test and post-test:

7. Which of the following best describes mountains? **Choose all that apply.**

- (A) Old mountains are generally taller because they have had more time to grow than young mountains
- (B) Old mountains tend to have gentler slopes than young mountains because there is more time for rocks to get worn away
- (C) Old mountains have more vegetation than young mountains because there is more time for plants to grow
- (D) Old mountains tend to have rougher surfaces than young mountains because more time has passed and things crack as they get older
- (E) All mountains are roughly the same age

Figure 16: Question number 7 from the pre-test/post-test.

In the pre-test, only one student (14% of the class) answered the question, shown in Figure 16, correctly, whereas in the post-test the number jumps to three correct answers (43%) of seven students, with three more students giving partially correct answers. This question has a greater difficulty than the TAKS question because it asks the students to synthesize more information. Instead of being told older mountains have a gentler slope and then asking why, this question asks the student to know that older mountains have gentler slopes and the reason why. With the question being more difficult, it is, therefore, permissible to include the three partially correct answers in the total number of correct answers. Including the partially correct answers in the total number of correct answers yields a correct answer rate of eighty-six percent, which is nine percent higher than these students' public school peers.

The second occurrence of a similar question was in the post-unit test. The students were given the question in Figure 17 below.

15. Describe how lava from a volcano can become sand on a beach.
Use a rock cycle diagram, including the arrows showing how the rock material changes to help you explain the process.

Figure 17: Question 15 from the post-unit test.

To answer this question correctly, students needed to include language regarding surface runoff water causing weathering and erosion. Three out of the ten students answered this question incorrectly. Five students answered this question correctly, with three of the five specifically mentioning wind or water induced weathering and erosion. One student did not answer the question, and one student gave a verbal answer, which was not recorded in detail. Sixty-two percent of the students answering this question on the exam answered correctly, which is fourteen percent less than their public school peers.

The third occurrence of a similar question is found in the students composite cycle diagrams. Each group of students was asked to draw a cause and effect diagram of all three of the systems studied in the unit (rock cycle, mantle convection cycle, and the water cycle). The diagrams for each group can be found in Appendix A pages 48 through 50. All three groups included weathering, erosion, and surface runoff associated with mountains or volcanoes in their diagrams.

DISCUSSION AND CONCLUSION

The students' pre-tests revealed a few misconceptions which stem from the students' limited subject knowledge and, in many cases, are logical results based on their knowledge level. The results of the post-test reflected the students' growth in the subject areas addressed by this research, as well as an overall increase in subject matter knowledge. The young-Earth-creationism curriculum that the students are taught does affect the students' answers to specific questions. The students who have been enrolled in this school longer, however, display more advanced abilities to reason through problems than students who have not been enrolled as long. This most likely is a result of the more individualized instruction and not the curriculum content.

The end of unit test results revealed some misconceptions that students held, as well as revealing which students were able to use higher level, critical thinking skills. The critical thinking was especially tough for these students. Observations in this classroom suggest that much of the students' resistance to critical thinking results from being overwhelmed when asked to do something they have never done before or to do something by themselves, with which they have always received help. At this age, scaffolding is critical and should be more structured than with older students. If the lesson is over-scaffolded, it is as if the instructor has given the student the answers. If the lesson is under-scaffolded, however, the students will be overwhelmed which will lead to confusion. Therefore, it is critical for teachers to find the correct balance and to know

their students as well. Some students have always been given the answers and will expect their current teacher to do the same. Teachers need to be able to distinguish between these students and students who are truly struggling with the material as these students need to be addressed differently.

Throughout the study students consistently showed a greater understanding for how the rock cycle interacts with the water cycle, and how these processes affect Earth. The mantle convection cycle, however, was not even included in the students' composite cycle diagrams. This shows a dichotomy between tangible science and conceptual science. The students had a more difficult time learning what they could not see, the mantle convection cycle. Whereas they mastered the science concept that they can see on a regular basis, it would be interesting to see if this is consistent on a larger scale and in other fields.

Many limitations exist in this study. In an idealized situation the sample size would be much larger. Ten subjects are too few to define statistically significant results. In an idealized situation multiple classrooms, schools, and possibly grades would be included in the study. It is difficult to find a public school where multiple classrooms are available to participate in a study like this because public schools must cover all of their required standards in a set amount of time and prepare for the standardized test. Time was also a limitation. It would be more beneficial to have more time to cover all of the material in more detail, as well as to scaffold the study specifically to the group of

students. With more time, students would also become more familiar with the Cause-MaP method, which would reduce their fear of the white space. Students would also ideally complete all of the activities individually to better measure each, individual, students' progress. A pre-test and post-test, geared specifically toward the material covered in this study, would also provide a better measure of the students' progress. It would also be beneficial if this study were completed across multiple science topics, i.e. physics, chemistry, biology etc.

Overall, the students who participated in this study compare well to the idealized standard, having mastered part of what is considered important material to include in sixth through eighth grade curriculum. These students showed their education to be comparable with the public schools in the area, even showing a more advanced understanding of the integration between the water cycle and the rock cycle. The results from this study show students who are encouraged to determine connections between different systems are more able to synthesize material that involves multiple interacting systems and answer question about it.

REFERENCES

- Assaraf, O. B. Z., and Orion, N., 2005, Development of System Thinking Skills in The Context of Earth System Education: *Journal of Research in Science Teaching*, v. 42, no. 5, p. 518-560.
- Clark, S. K., Sibley, D. F., Libarkin, J. C., and Heidemann, M., 2009, A Novel Approach to Teaching and Understanding Transformations of Matter in Dynamic Earth Systems: *Journal of Geoscience Education*, v. 57, no. 4, p. 223.
- Project 2061 (American Association for the Advancement of Science), 2001, *Atlas of Science Literacy*. v.1: Washington, DC, American Association for the Advancement of Science: National Science Teachers Association.
- Raia, F.. (2008). Causality in Complex Dynamic Systems: A Challenge in Earth Systems Science Education. *Journal of Geoscience Education*, 56(1), 81-94. Retrieved March 31, 2011, from ProQuest Education Journals.
- Rostan, S. M., 1994, Problem Finding, Problem Solving, and Cognitive Controls: An Empirical Investigation of Critically Acclaimed Productivity: *Creativity Research Journal*, v. 7, no. 2, p. 97-110.
- Schroeder, C. M., 2006, Expert-novice interaction in problematizing a complex environmental science issue using web-based information and analysis tools, Ph. D. Dissertation. Texas A&M University, College Station.

APPENDIX A

Student Work

Students End of Unit Test Answers

Student 1

14. Explain how the part of the lithosphere marked A on the map below can be moved into the layer of the Earth marked B. Describe the steps and draw a diagram.

_____ 2

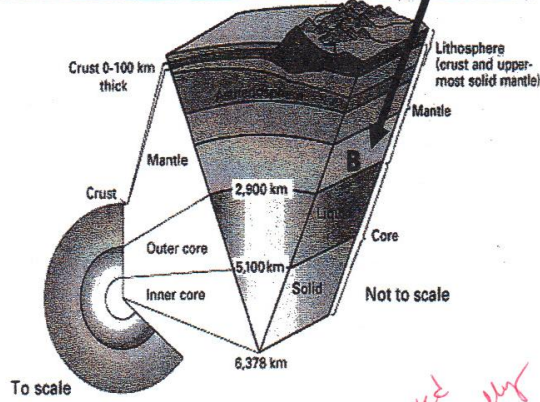
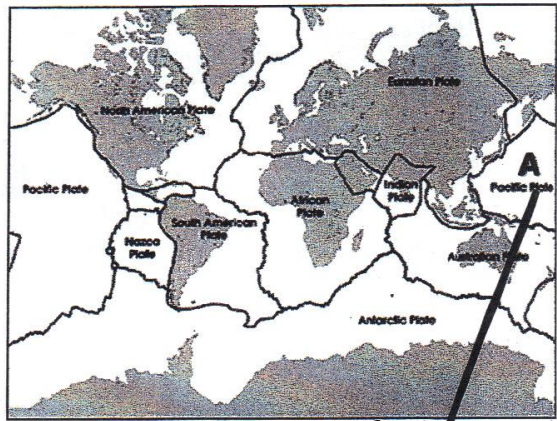

answered verbally

15. Describe how lava from a volcano can become sand on a beach. Use a rock cycle diagram, including the arrows showing how the rock material changes to help you explain the process.

Thurs weathering, erosion

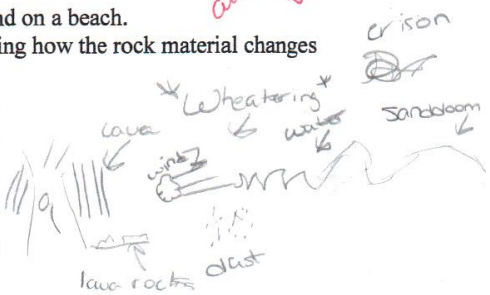

Student 2

14. Explain how the part of the lithosphere marked A on the map below can be moved into the layer of the Earth marked B. Describe the steps and draw a diagram.

Since the plate is very dense, it can slowly be moved into the mantle with help from gravity.

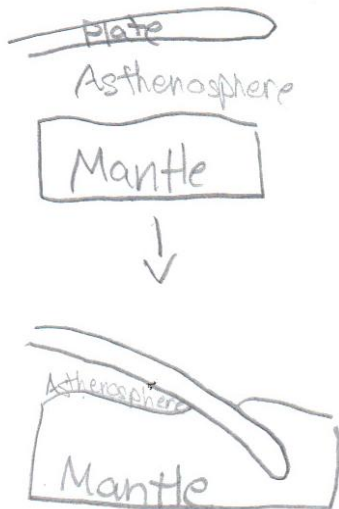
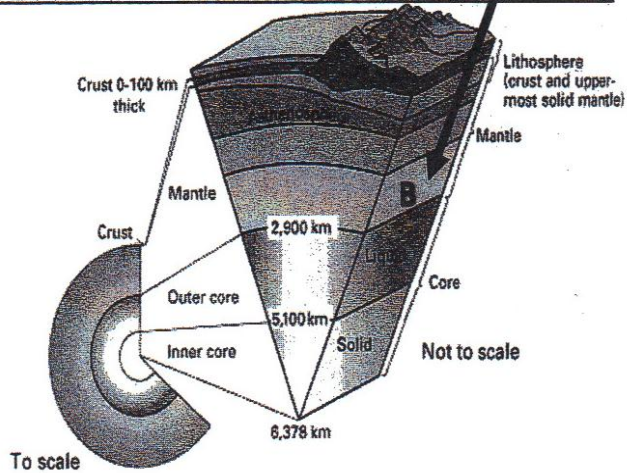
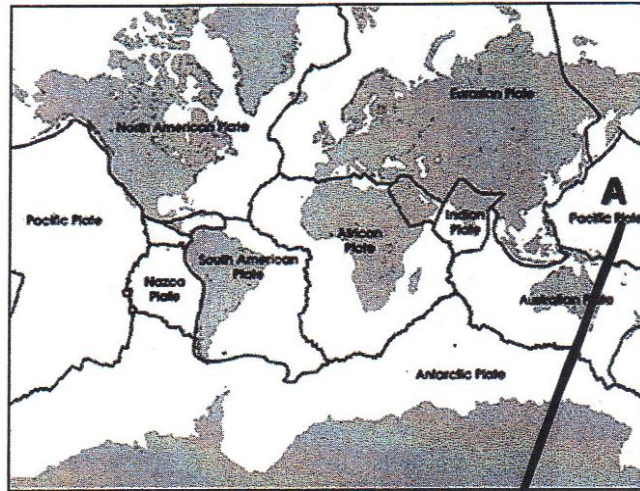

15. Describe how lava from a volcano can become sand on a beach.

Use a rock cycle diagram, including the arrows showing how the rock material changes to help you explain the process.

It goes through the melting and cooling process, then the wind blows the rock into the water + over time it breaks into pieces + it lands on the beach.



Student 3

14. Explain how the part of the lithosphere marked A on the map below can be moved into the layer of the Earth marked B. Describe the steps and draw a diagram.

The oceanic crust can pull the continental crust down. This theory is called the "slab-pull".

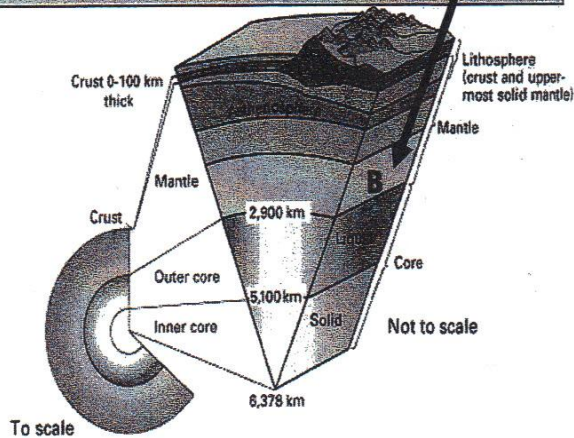
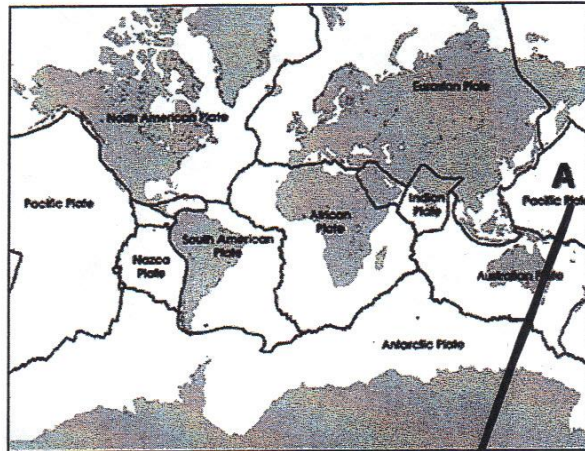

15. Describe how lava from a volcano can become sand on a beach.

Use a rock cycle diagram, including the arrows showing how the rock material changes to help you explain the process.

First, the volcano erupts then the lava goes towards the ocean. Next, the water cools it. Finally, lava dries on the beach.

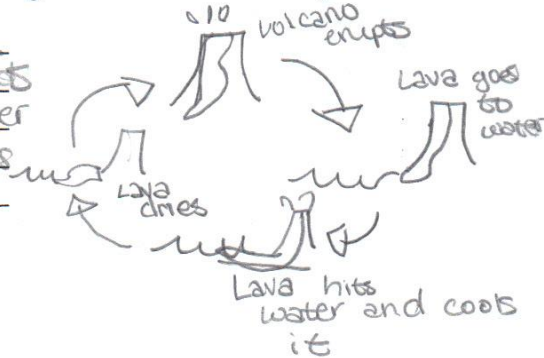

Student 5

14. Explain how the part of the lithosphere marked A on the map below can be moved into the layer of the Earth marked B. Describe the steps and draw a diagram.

The Eurasian + Pacific plate collide and causes subduction which means the Pacific plate goes into the mantle and burns up.

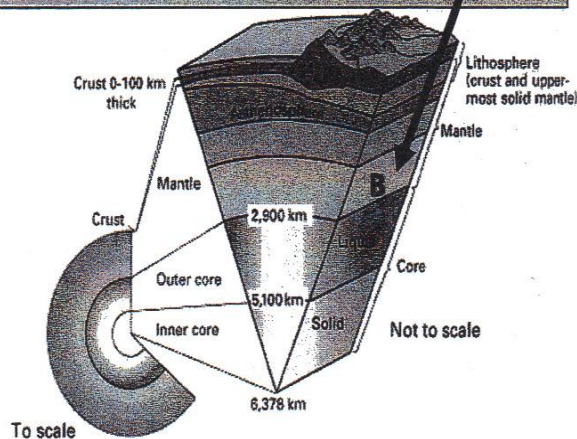
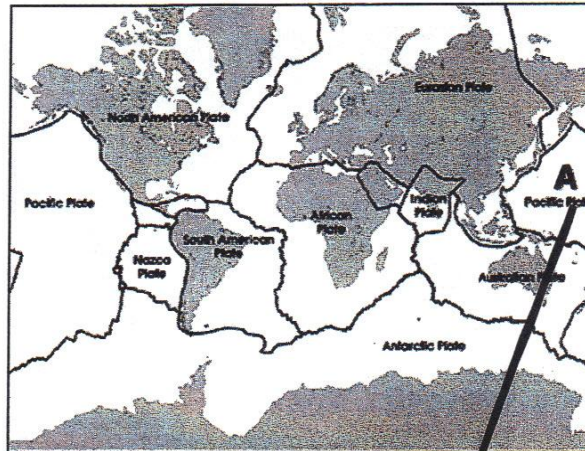

15. Describe how lava from a volcano can become sand on a beach.

Use a rock cycle diagram, including the arrows showing how the rock material changes to help you explain the process.

The lava cools and turns into igneous rock and the weathering, erosion, sedimentation, cementation, and compaction occur to make it a sedimentary rock. Then the rock gets weathered again and becomes sediment.

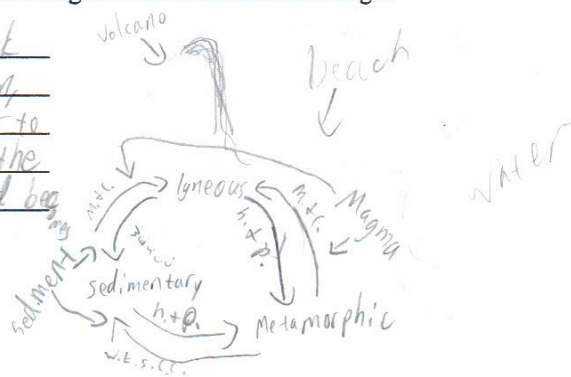

Student 5

14. Explain how the part of the lithosphere marked A on the map below can be moved into the layer of the Earth marked B. Describe the steps and draw a diagram.

The Pacific Plate may hit Eurasian Plate and slide under into the Mantle. This would happen because both plates are different densities.

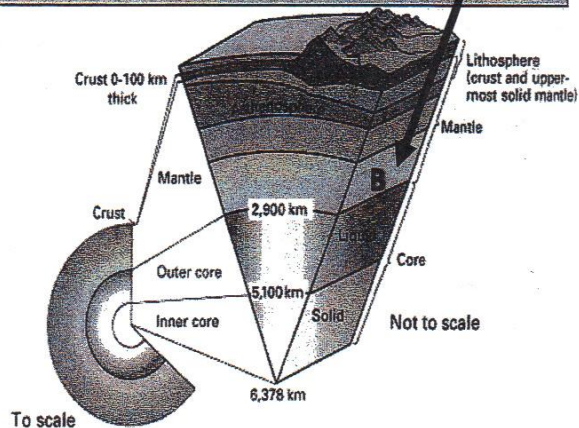
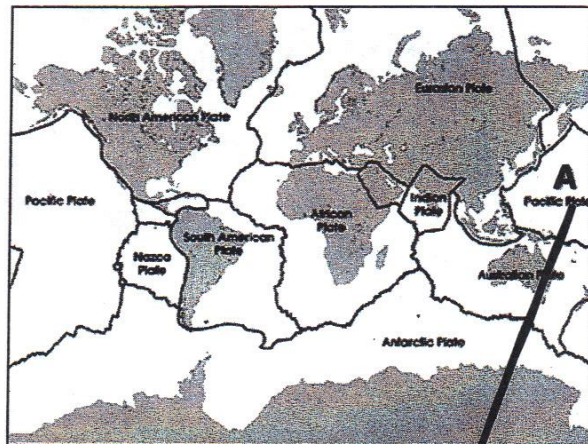

15. Describe how lava from a volcano can become sand on a beach.

Use a rock cycle diagram, including the arrows showing how the rock material changes to help you explain the process.

Lava erupts, cools, and becomes igneous rock. It is then weathered and deposited on to a beach by a river as little chunks of sediment.



Student 7

14. Explain how the part of the lithosphere marked A on the map below can be moved into the layer of the Earth marked B. Describe the steps and draw a diagram.

The lithosphere can be moved into the mantle by slab pull. Slab pull is when two plates are converging, and one slides under the other.

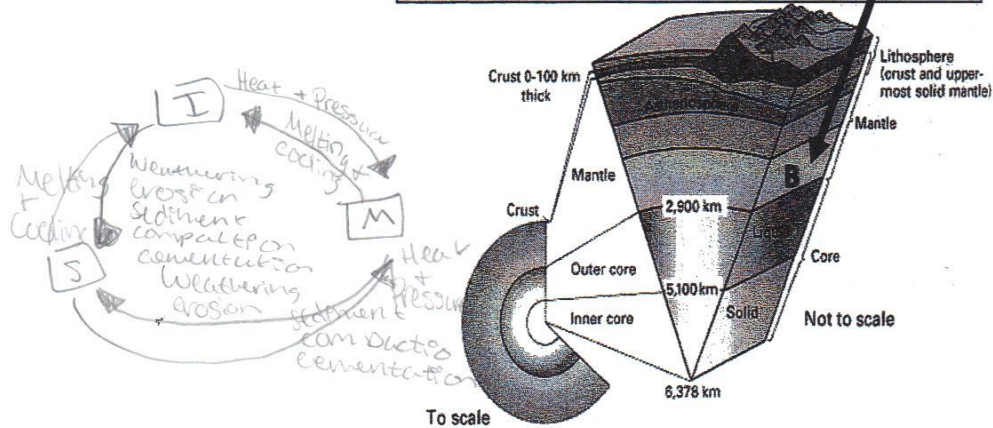
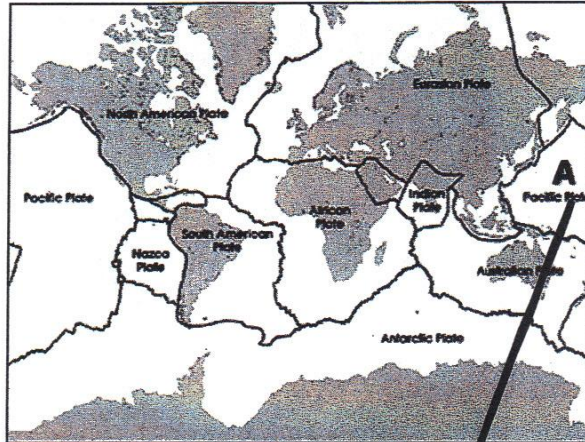

15. Describe how lava from a volcano can become sand on a beach. Use a rock cycle diagram, including the arrows showing how the rock material changes to help you explain the process.

The lava would cool, it would be weathered & then eroded by wind.

Student 9

14. Explain how the part of the lithosphere marked A on the map below can be moved into the layer of the Earth marked B. Describe the steps and draw a diagram.

they can
move towards
each other
causing
A to go down.

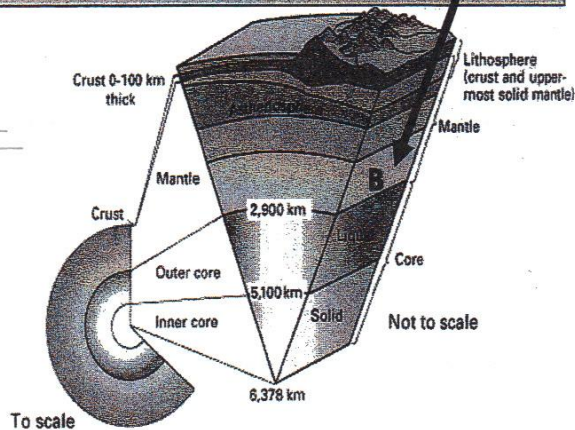
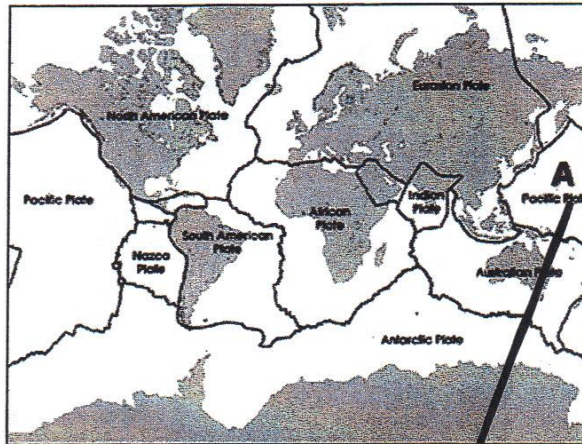

15. Describe how lava from a volcano can become sand on a beach. Use a rock cycle diagram, including the arrows showing how the rock material changes to help you explain the process.

the volcano explodes
and weather then
erodes and becomes
sand

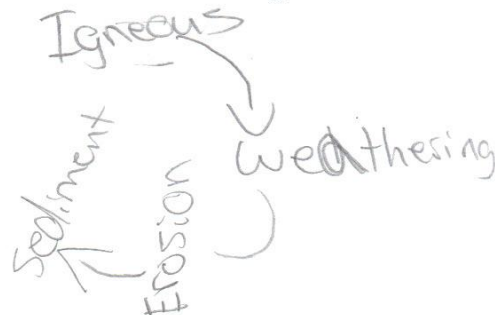

Student 10

14. Explain how the part of the lithosphere marked A on the map below can be moved into the layer of the Earth marked B. Describe the steps and draw a diagram.

The slab will pull the lithosphere into the mantle because of gravity.

✓

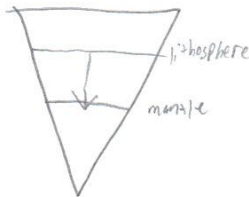
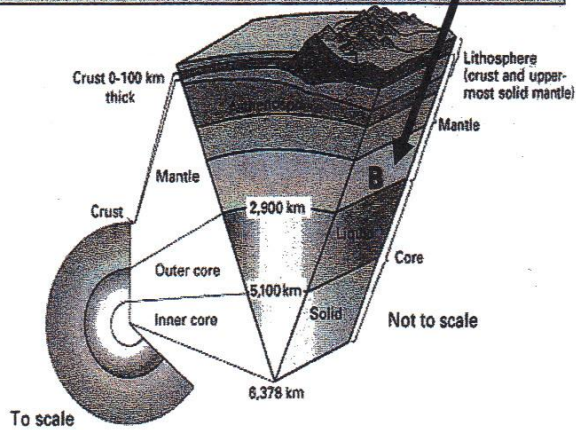
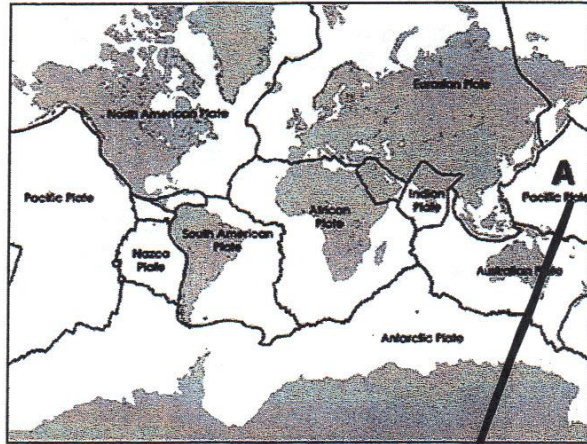

15. Describe how lava from a volcano can become sand on a beach.

Use a rock cycle diagram, including the arrows showing how the rock material changes to help you explain the process.

It would have to cool, then weathering, + erosion.

✓

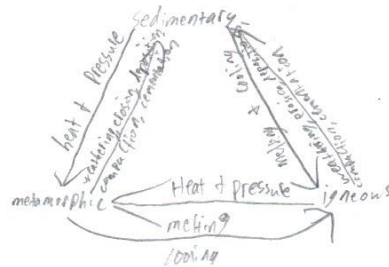

14. Explain how the part of the lithosphere marked A on the map below can be moved into the layer of the Earth marked B. Describe the steps and draw a diagram.

The plates on A
 could shift
 causing an
 earth quake,
 which makes
 it go down
 to B

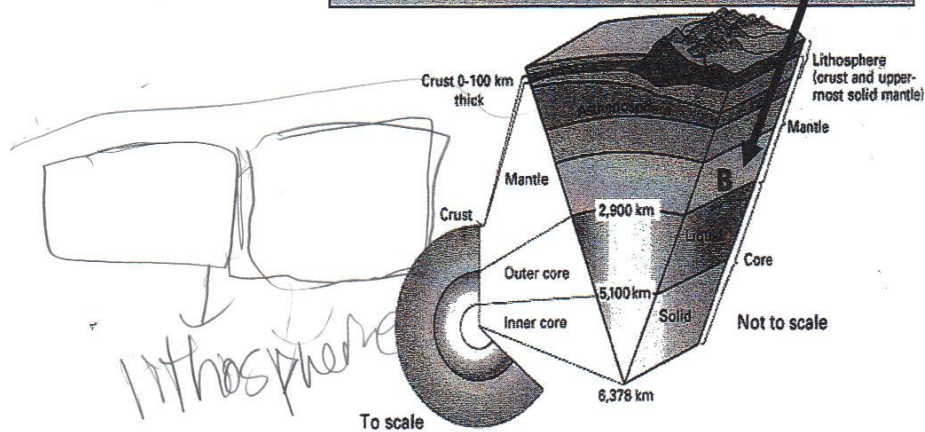
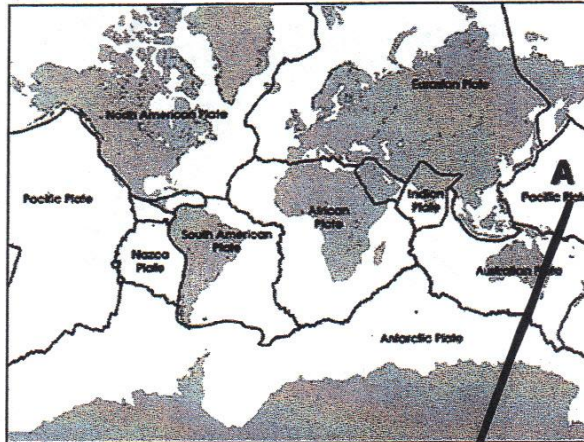

15. Describe how lava from a volcano can become sand on a beach. Use a rock cycle diagram, including the arrows showing how the rock material changes to help you explain the process.

Magma goes through
 melting + cooling or then it
 becomes igneous then it goes
 through cementation + makes
 sed.

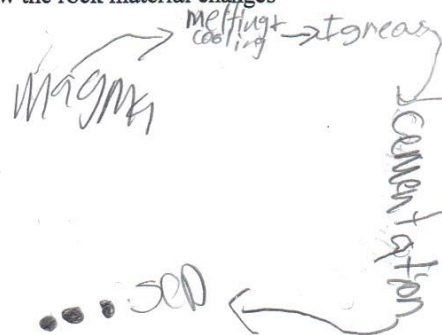

Composite Cycle Diagrams

Group 1

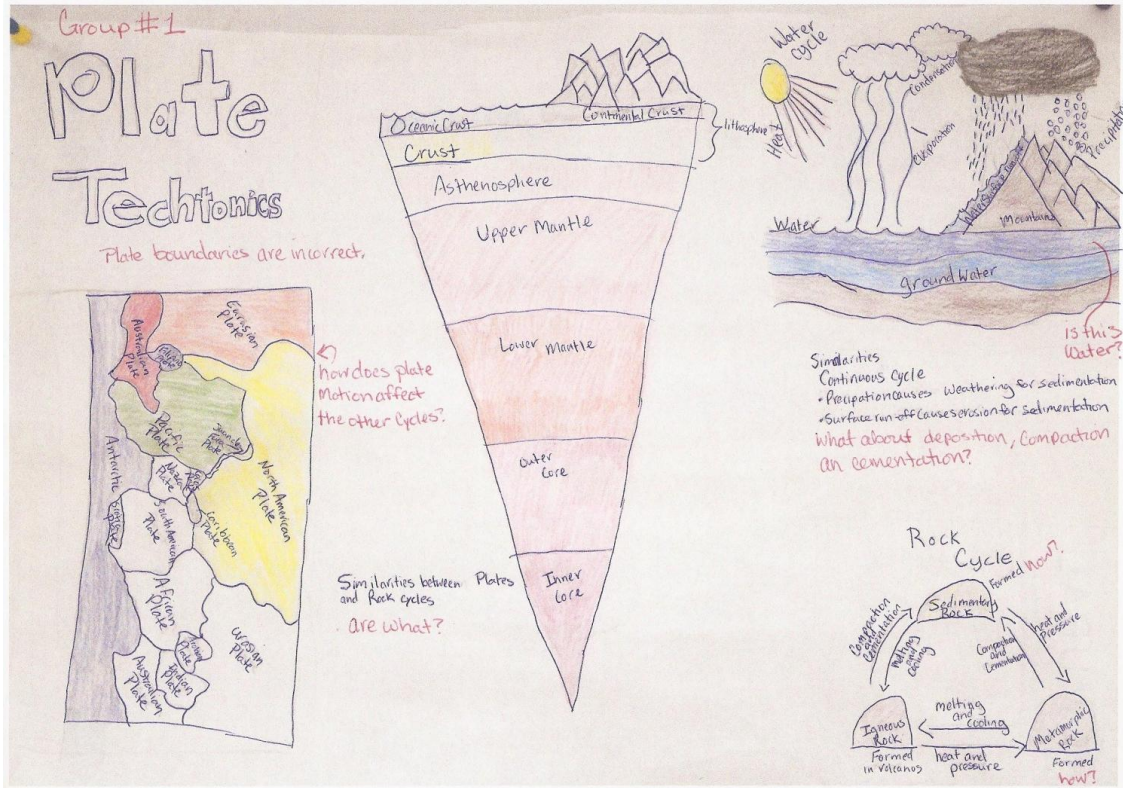

Group 2

Group #2

ROCK Cycle

what about weathering? erosion is the transport of weathered sediment. what happens to the sediment?

Metamorphic Rock $\xrightarrow{\text{heat + pressure}}$ Igneous Rock $\xrightarrow{\text{magma}}$ Sedimentary Rock $\xrightarrow{\text{weathering, erosion, deposition, compaction, cementation}}$ Metamorphic Rock

Metamorphic rocks can become sedimentary rocks.

Water Cycle

Evaporation (Salt Water) \rightarrow Condensation \rightarrow Precipitation (Rain/Snow) \rightarrow Infiltration \rightarrow Percolation \rightarrow Ground Water \rightarrow Collection (Fresh Water) \rightarrow Evaporation

Plate Tectonics

What is this line indicating?

What important roll do plates play in the plate tectonic theory and mantle convection cycle?

What about mantle convection and the layers of the earth?

Do any of these processes affect any of these other cycles? It looks like this cycle is isolated.

Group 3

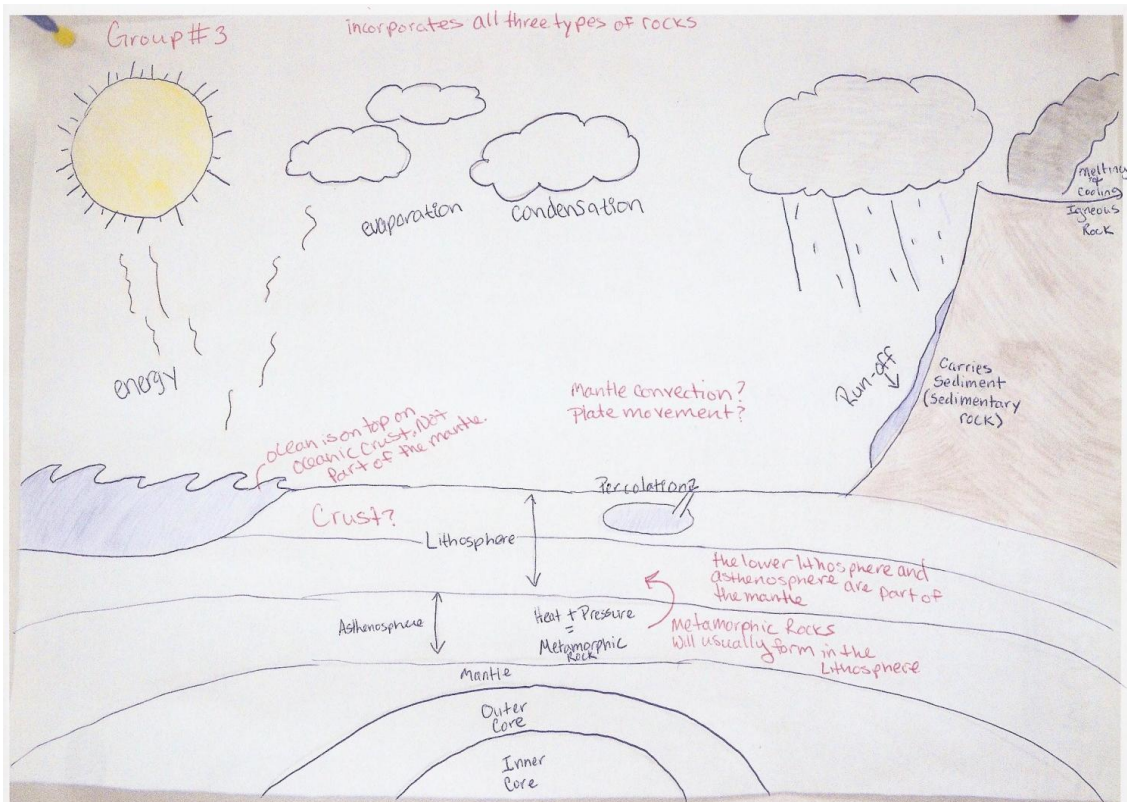

APPENDIX B*

Idealized Earth Systems Tables

Idealized table for the rock cycle

Forming	Q2: 2. What types of rock form from these materials? What are the steps in between that are associated with these rock types?	Q3: 3. What processes cause the rocks to form and break down?	Causes	Q4: What vocabulary word have you learned for this process?	Which is/ of	Q5: 5. What is changing or moving? Are there phase changes? Physical changes? Any other kinds of changes to the material?	Description of what this looks like
Forming	Igneous Rock	cooling	Causes	solidification	Which is	a phase change from liquid to solid	
Forming	Sediment	weather/ climate	Causes	weathering	of	a physical change of igneous, sedimentary, or metamorphic rock to sediment	
Forming	Sedimentary Rock	compaction and cementation	Causes	lithification	of	a physical change of sediment to sedimentary rock	
Forming	Metamorphic Rock	heat and pressure	Causes	metamorphism	of	a physical change of sedimentary, igneous, or metamorphic rock to metamorphic rock	
Forming	Magma	heating of rock	Causes	melting	Which is	a phase change from solid to liquid	
Forming	Sedimentary Rock: example - Halite	Evaporation	Causes	lithification	Which is	forming of rocks by drying up water and leaving the minerals behind	

*Part of this Chapter has been reprinted with permission from *Atlas of Science Literacy*, by Project 2061, 2001, American Association for Advancement of Science, Washington DC. Copyright 2001 by Project 2061.

Idealized table for the mantle convection cycle

Forming	Q2: 2. What materials and layers of the Earth are involved in the mantle convection and plate tectonic cycle?	Q3: 3. What processes cause these cycles to occur?	Causes	Q4: What are the results? What vocabulary words have you learned for this process?	Which is/ of	Q5: 5. What is changing or moving? Are there phase changes? Physical changes? Any other kinds of changes to the material?	Description of what this looks like and where it might occur
Forming	Lithosphere	creation of new rock where plates pull apart and destruction of old rock where plates collide	Causes	solidification and subduction	Which is	phase change from liquid magma to solid rock. A temperature change as the lithosphere is forced downward rejoining the asthenosphere/mantle	solid, rigid crust and upper mantle. Not gooey like the mantle
Forming	Asthenosphere	heat from inside the earth	Causes	Convection current	of	mantle closer to the core heats up more and decreases in density, while the mantle farther from the core is heated less causing an increase in density	gooey, under the lithosphere
Forming	Magma	heat from inside the earth	Causes	a decrease in density	of	the liquid magma then rises sometimes cooling under the surface and sometimes	liquid
Forming	Lava	escape of magma to the surface of the Earth	Causes	volcano, divergent boundary	of	liquid (molten) rock is pushed to the surface of the crust/lithosphere	hawaii, subduction (convergent plate boundary) divergent plate boundary

Idealized Earth Science Educational Objectives

Atlas of Science Literacy Earth science concept map

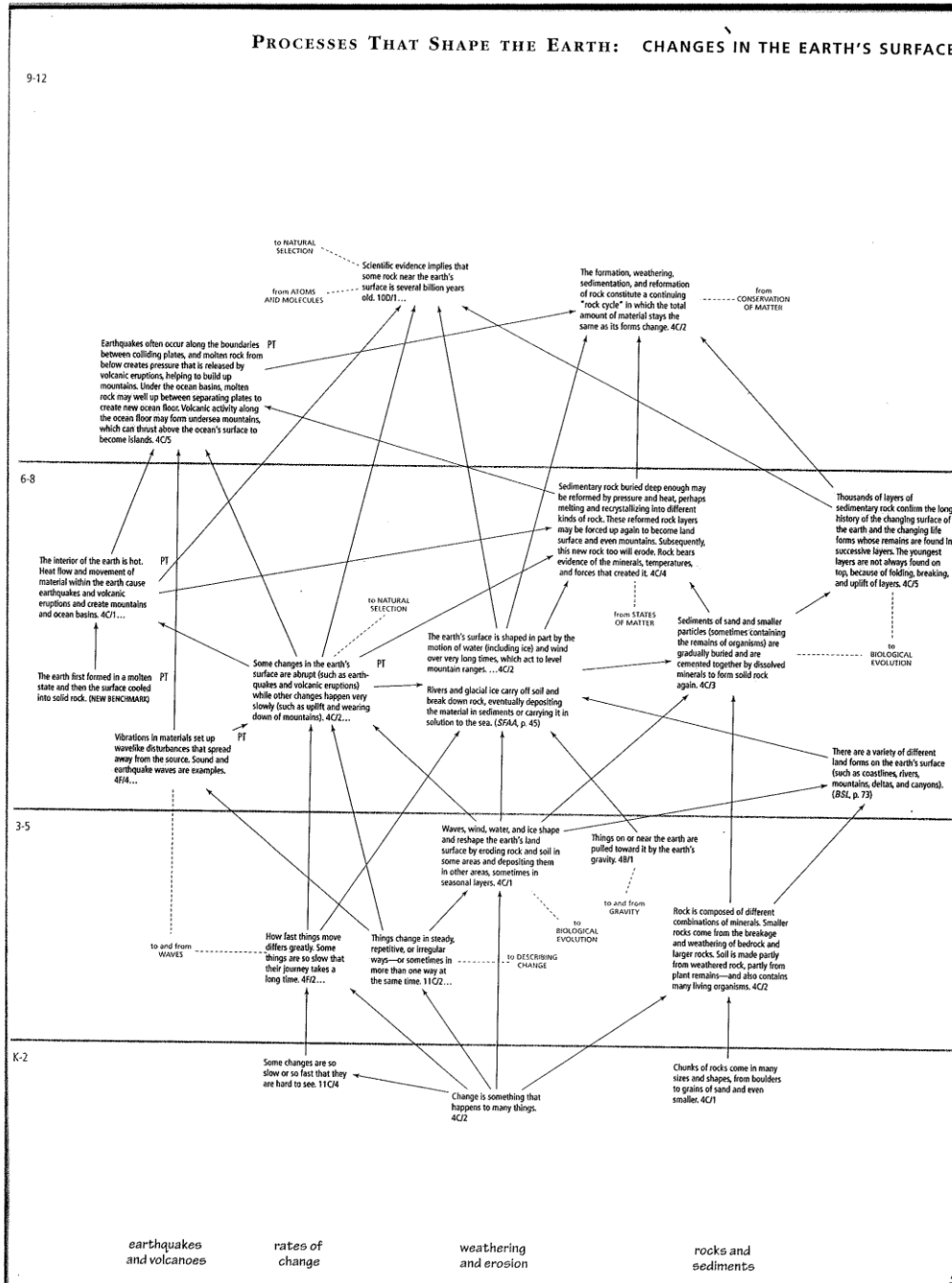

The full concept map from the American Association for the Advancement of Science, *Atlas of Science Literacy*, Vol. 1, 2001 page 51 which addresses grades kindergarten through twelve (Project 2061, 2001, pg 51). Reprinted with permission.

APPENDIX C

Assessment tools

Earth Systems Pre-test/Post-test

Earth Systems Pretest

1. Some scientists claim that they can determine when the Earth first formed as a planet. Which technique(s) do scientists use today to determine when the Earth first formed? **Choose all that apply.**
 - (A) Comparison of fossils found in rocks
 - (B) Comparison of different layers of rock
 - (C) Analysis of uranium and lead in rock
 - (D) Analysis of carbon in rock
 - (E) Scientists cannot calculate the age of the Earth
2. Which of the following can greatly affect erosion rates? **Choose all that apply.**
 - (A) Rock type
 - (B) Earthquakes
 - (C) Time
 - (D) Climate
3. If the single continent in #4 did exist, how long did it take for the single continent to break apart and form the arrangement of continents we see today?
 - (A) Hundreds of years
 - (B) Thousands of years
 - (C) Millions of years
 - (D) Billions of years
 - (E) It is impossible to tell how long the break up would have taken
4. Some people believe there was once a single continent on Earth. Which of the following statements best describes what happened to this continent?
 - (A) Meteors hit the Earth causing the continent to break into smaller pieces
 - (B) The Earth lost heat over time and cracked, causing the continent to break into smaller pieces
 - (C) Material beneath the continent moved, causing the continent to break into smaller pieces
 - (D) The Earth gained heat over time and cracked, causing the continent to break into smaller pieces
 - (E) Only a small number of people believe there was once a single continent, and it is more likely that the continents have always been in roughly the same place as they are today
5. Where do you think glaciers can be found today? **Choose all that apply.**
 - (A) In the mountains
 - (B) At sea level
 - (C) At the South pole
 - (D) Along the equator only
 - (E) Anywhere except along the equator

6. Which of the following statements about the age of rocks is most likely true?

- (A) Rocks found in the ocean are about the same age as rocks found on continents
- (B) Rocks found on continents are generally older than rocks found in the ocean
- (C) Rocks found in the ocean are generally older than rocks found on continents
- (D) None of the above; we cannot figure out the age of rocks precisely enough to figure out which rocks are older

7. Which of the following best describes mountains? **Choose all that apply.**

- (A) Old mountains are generally taller because they have had more time to grow than young mountains
- (B) Old mountains tend to have gentler slopes than young mountains because there is more time for rocks to get worn away
- (C) Old mountains have more vegetation than young mountains because there is more time for plants to grow
- (D) Old mountains tend to have rougher surfaces than young mountains because more time has passed and things crack as they get older
- (E) All mountains are roughly the same age

8. What is the connection between clouds and rain?

- (A) Clouds are empty, and fill up with water. When the clouds are full, it rains
- (B) Clouds are empty, and fill up with water and other things, like pollution or minerals. When the clouds are full, it rains
- (C) Clouds are empty, and fill up with water. When the clouds get too heavy, it rains
- (D) Clouds are made up of water, and when the temperature gets high enough in the cloud, it rains
- (E) Clouds are made up of water, and when the temperature gets low enough in the cloud it rains

9. Where are most rocks formed?

- (A) Most rocks form underground and are pushed to the surface by magma.
- (B) Most rocks form underground and are exposed when overlying rocks are removed.
- (C) Most rocks form underground, but can never travel to the surface.
- (D) Most rocks form at the Earth's surface.

10. Which of the following can be caused by wind? **Choose all that apply.**

- (A) Movement of tectonic plates
- (B) Waves
- (C) Earthquakes
- (D) Mountain-building
- (E) Erosion

11. What is groundwater?

- (A) All liquid water that resides beneath the Earth's surface
- (B) Muddy mixture of water and dirt that lies beneath the Earth's surface
- (C) Only the water found in underground lakes and rivers that is clean enough to drink
- (D) Only water that is moving beneath the Earth's surface
- (E) Only water that is stationary beneath the Earth's surface

12. Where can groundwater be found?

- (A) Only in wet climates
- (B) Only where there is dirt since water cannot move through rock
- (C) Groundwater can exist in rock or soil, but will not be found beneath the Earth's surface
- (D) Only where underground rivers connect to a spring
- (E) Almost anywhere beneath the Earth's surface

13. What causes most of the waves in the ocean?

- (A) Tides
- (B) Earthquakes
- (C) Wind
- (D) Tsunamis

14. If you could travel millions of years into the future, how big would the planet Earth be?

- (A) Smaller than today
- (B) Larger than today
- (C) Same size as today
- (D) We have no way of knowing

15. Which of the figures below do you think most closely represents changes in life on Earth over time?

Choose one: A B C D E

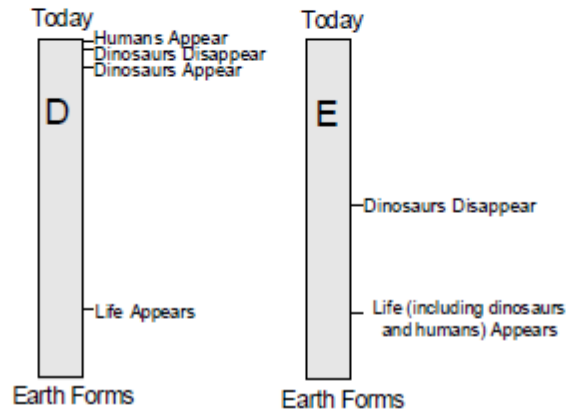
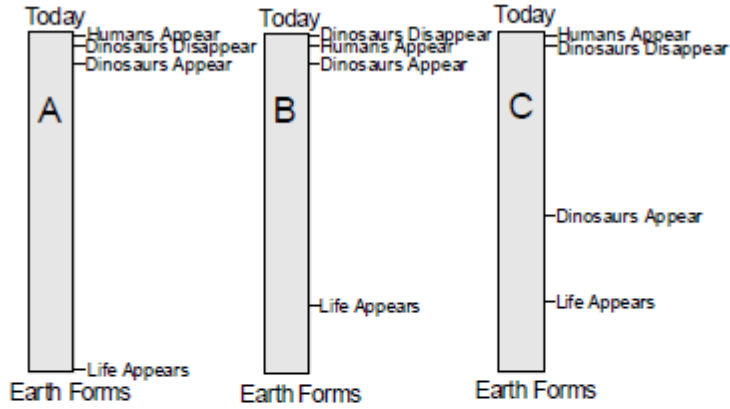

End of Unit Test Questions

14. Explain how the part of the lithosphere marked A on the map below can be moved into the layer of the Earth marked B. Describe the steps and draw a diagram.

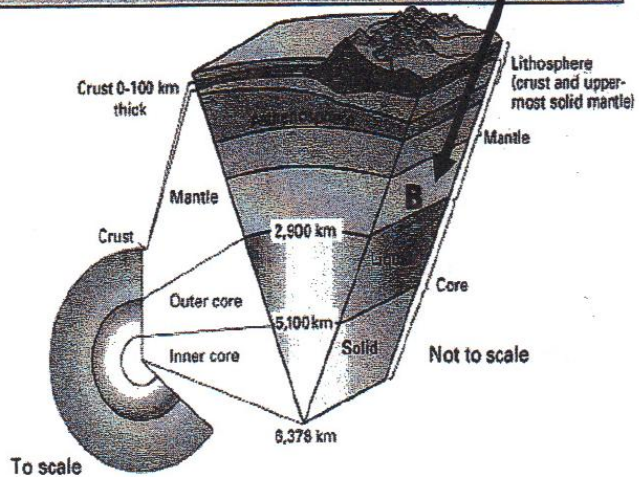
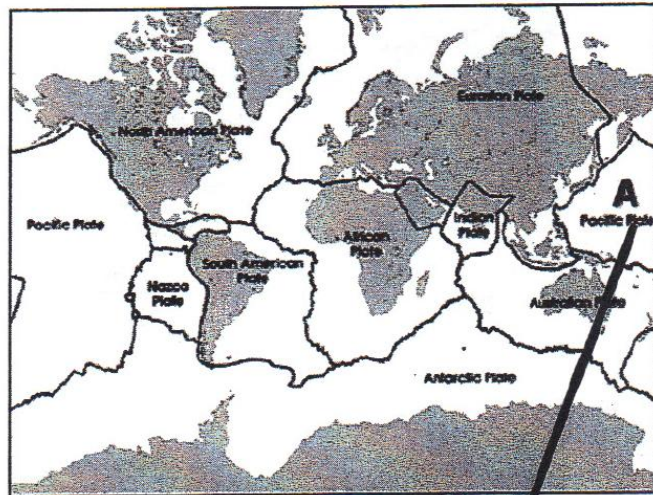

15. Describe how lava from a volcano can become sand on a beach.
Use a rock cycle diagram, including the arrows showing how the rock material changes to help you explain the process.

Grading rubric for composite cycle diagram Group 1

Group #1

	poor (1pt)	below-average (2pt)	average (3pt)	above-average (4pt)	excellent (5pt)	Total
vocabulary used	uses no appropriate vocabulary	uses some appropriate vocabulary for 1 of the systems	uses some appropriate vocabulary for 2 of the 3 systems	uses some appropriate vocabulary for all 3 systems	uses most appropriate vocabulary for all 3 systems	4/5
figures used	includes very few elements involved in the systems	includes some elements involved in 1 of the 3 systems	includes some elements involved in 2 of the 3 systems	includes some elements involved in all 3 systems	includes most elements involved in all 3 systems	4/5
relationships between earth systems	shows no interrelationship between the 3 systems	shows only slight relationship between two systems	shows integration between two systems	shows some relations between all three systems	shows intricate relations between all three systems	2/5
rock cycle	students' rock cycle is incorrect	students' rock cycle is partly correct with few to no big mistakes	students' rock cycle is mostly correct with no big mistakes	students' rock cycle is completely correct	students' rock cycle is completely correct and includes additional, unexpected, or outstanding features	4/5
water cycle	students' water cycle is incorrect	students' water cycle is partly correct with few to no big mistakes	students' water cycle is mostly correct with no big mistakes	students' water cycle is completely correct	students' water cycle is completely correct and includes additional, unexpected, or outstanding features	5/5
mantle convection cycle	includes layers of the earth, both physical and chemical	the layers are depicted keeping in mind the scale of the separate layers	the depiction includes crust subduction	the depiction includes mantle convection	the depiction includes temperature differentials as a reason for mantle convection	1/5
Total:						20/30

Grading rubric for composite cycle diagram Group 2

Group #2

	poor (1pt)	below-average (2pt)	average (3pt)	above-average (4pt)	excellent (5pt)	Total
vocabulary used	uses no appropriate vocabulary	uses some appropriate vocabulary for 1 of the systems	uses some appropriate vocabulary for 2 of the 3 systems	uses some appropriate vocabulary for all 3 systems	uses most appropriate vocabulary for all 3 systems	3/5
figures used	includes very few elements involved in the systems	includes some elements involved in 1 of the 3 systems	includes some elements involved in 2 of the 3 systems	includes some elements involved in all 3 systems	includes most elements involved in all 3 systems	3/5
relationships between earth systems	shows no interrelationship between the 3 systems	shows only slight relationship between two systems	shows integration between two systems	shows some relations between all three systems	shows intricate relations between all three systems	2/5
rock cycle	students' rock cycle is incorrect	students' rock cycle is partly correct with few to no big mistakes	students' rock cycle is mostly correct with no big mistakes	students' rock cycle is completely correct	students' rock cycle is completely correct and includes additional, unexpected, or outstanding features	5/5
water cycle	students' water cycle is incorrect	students' water cycle is partly correct with few to no big mistakes	students' water cycle is mostly correct with no big mistakes	students' water cycle is completely correct	students' water cycle is completely correct and includes additional, unexpected, or outstanding features	5/5
mantle convection cycle	includes layers of the earth, both physical and chemical	the layers are depicted keeping in mind the scale of the separate layers	the depiction includes crust subduction	the depiction includes mantle convection	the depiction includes temperature differentials as a reason for mantle convection	0/5
Total:						18/30

Grading rubric for composite cycle diagram Group 3

Group #3

	poor (1pt)	below-average (2pt)	average (3pt)	above-average (4pt)	excellent (5pt)	Total
vocabulary used	uses no appropriate vocabulary	uses some appropriate vocabulary for 1 of the systems	uses some appropriate vocabulary for 2 of the 3 systems	uses some appropriate vocabulary for all 3 systems	uses most appropriate vocabulary for all 3 systems	4/5
figures used	includes very few elements involved in the systems	includes some elements involved in 1 of the 3 systems	includes some elements involved in 2 of the 3 systems	includes some elements involved in all 3 systems	includes most elements involved in all 3 systems	4/5
relationships between earth systems	shows no interrelationship between the 3 systems	shows only slight relationship between two systems	shows integration between two systems	shows some relations between all three systems	shows intricate relations between all three systems	3/5
rock cycle	students' rock cycle is incorrect	students' rock cycle is partly correct with few to no big mistakes	students' rock cycle is mostly correct with no big mistakes	students' rock cycle is completely correct	students' rock cycle is completely correct and includes additional, unexpected, or outstanding features	3/5
water cycle	students' water cycle is incorrect	students' water cycle is partly correct with few to no big mistakes	students' water cycle is mostly correct with no big mistakes	students' water cycle is completely correct	students' water cycle is completely correct and includes additional, unexpected, or outstanding features	5/5
mantle convection cycle	includes layers of the earth, both physical and chemical	the layers are depicted keeping in mind the scale of the separate layers	the depiction includes crust subduction	the depiction includes mantle convection	the depiction includes temperature differentials as a reason for mantle convection	1/5
Total:						28/30